

FANS

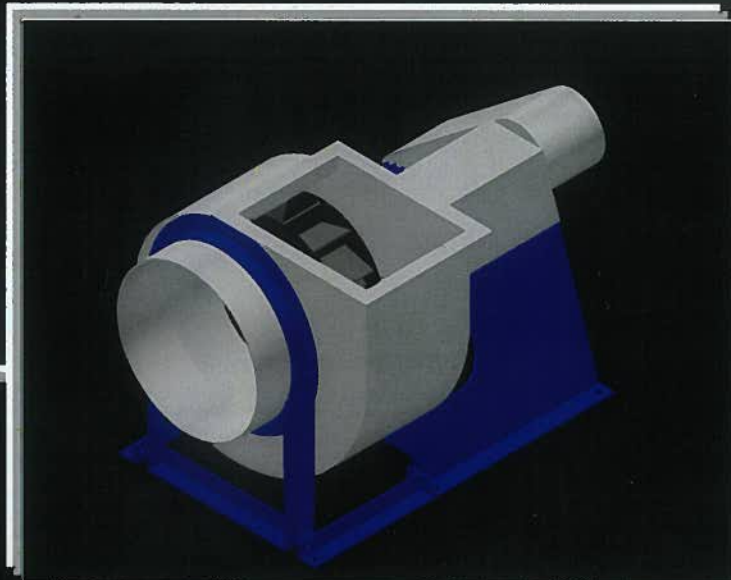

CORROSION RESISTANT FANS PVC, POLY-PRO, AND FRP

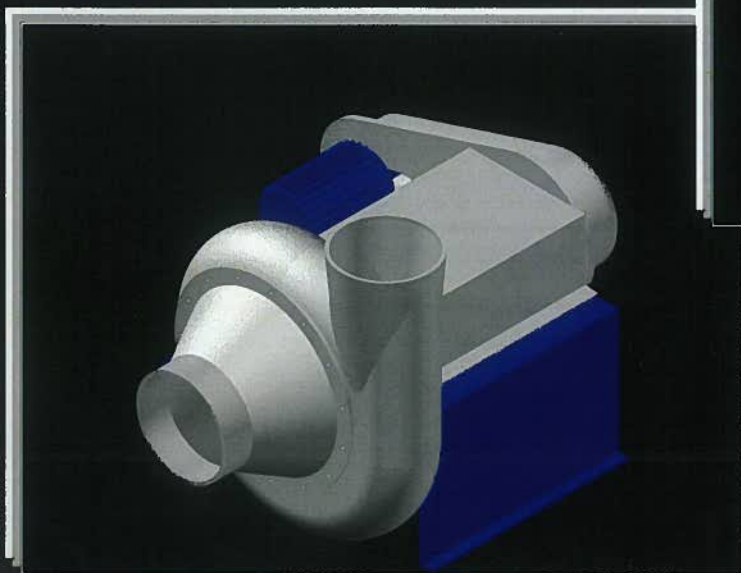

KCH Services certifies that the CI and NH Fans shown herein are licensed to bear the AMCA Seal. The ratings shown are based on tests and procedures performed in accordance with AMCA publication 211 and comply with the requirements of the AMCA



Unusually Quiet

Type NH Fans, with their stable and efficient performance, are quiet in operation. In fact, quietness is one of the principal features of the Type NH design.

It should be emphasized that maximum quietness in actual operation depends not only on the choice of the fan itself, but also the system of which the fan is a part. Poorly designed ductwork of too light construction or with abrupt turns, as well as improper fan foundations, lack of proper isolation between fan and ducts, and poor acoustical conditions adversely affect the sound level of the installation.

A guide for selection of fan outlet velocities at various static pressures is shown in the table on the right. In general, choosing a lower outlet velocity for the static pressure involved results in quieter operation.

RECOMMENDED OUTLET VELOCITY FOR QUIET OPERATION	
STATIC PRESSURE	OUTLET VELOCITY RANGE
1/4"	700 - 1000
3/8"	800 - 1100
1/2"	900 - 1200
5/8"	975 - 1300
3/4"	1050 - 1400
7/8"	1125 - 1500
1"	1200 - 1600
1 1/4"	1300 - 1750
1 1/2"	1400 - 1900
1 3/4"	1500 - 2050
2"	1600 - 2200
2 1/2"	1800 - 2500

Excellent Performance

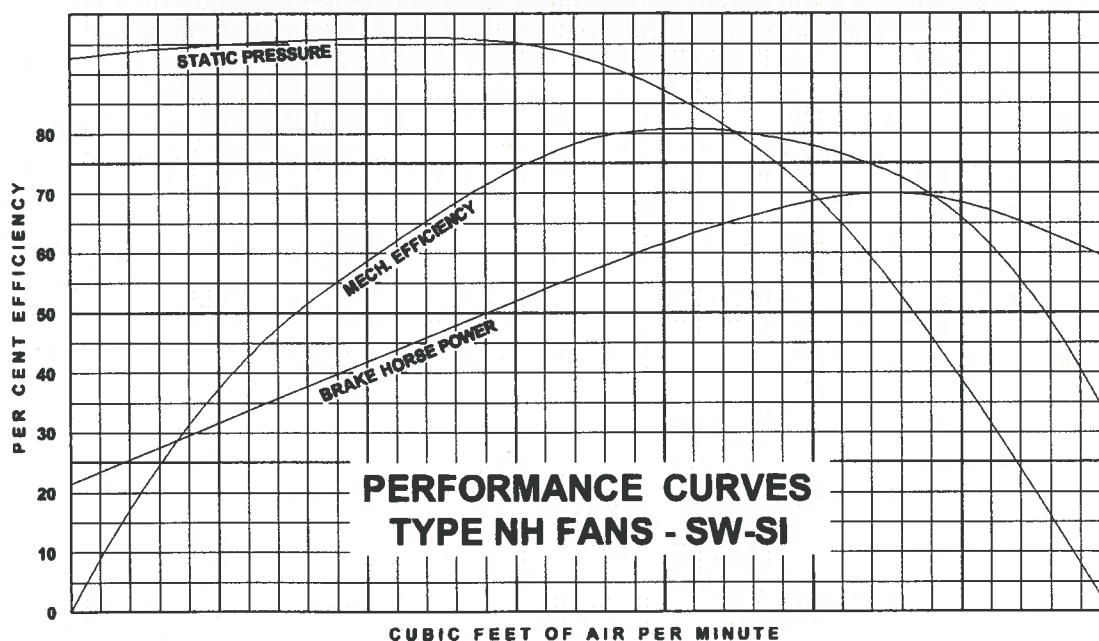

PERFORMANCE AT OTHER THAN STANDARD CONDITIONS

Any particular fan, operating at a constant speed on a fixed system when there is no internal heat exchange involved, will deliver the same volume of air but the static pressure and brake horsepower will vary with the density. The capacity tables in this catalog are based on the fan handling standard air at a density of .075 lbs. per cubic foot corresponding to 70° F. and 29.92" Hg. barometric pressure. Therefore when the fan handles air or other gases at other than standard densities due to temperature, altitude or the kind of gas, the published tables should be used in the following manner.

GENERAL METHOD

Step 1 Compute the equivalent static pressure in the following manner:

$$\text{Equivalent SP} = \text{Required SP} \times \frac{.075}{\text{Actual Density}}$$

When both temperature and altitude vary from standard,

$$\text{Actual density} = \frac{\text{Density at temp.} \times \text{density at alt.}}{.075}$$

(See chart below)

Step 2 Using the required CFM and the equivalent SP, obtain the RPM and BHP from the standard capacity table, interpolating when necessary.

Step 3 The RPM obtained is the correct value. The BHP obtained must be corrected for the actual density as follows:

$$\text{BHP (from table)} \times \frac{\text{Actual density}}{.075}$$

EXAMPLE

Determine RPM and BHP required for a No. 40 1/4 NH fan, SW-SI for 16,800 CFM, 1 1/2" SP, 250° F., 5000' altitude.

Step 1 $\text{Equivalent SP} = 1.5 \times \frac{.075}{.0465} = 2.42"$

$$\text{Actual density} = \frac{.056 \times .0623}{.075} = .0465$$

Where .056 is read from temperature curve and .0623 from the altitude curve. (See chart below.)

Step 2 From Capacity Table for No. 40 1/4, by interpolation:
RPM = 699
BHP = 9.07

Step 3 Actual RPM required = 699

$$\text{Actual BHP} = 9.07 \times \frac{.0465}{.075} = 5.62$$

Correct performance is:

16,800 CFM, 1 1/2" SP, 699 RPM, 5.62 BHP, when handling air at 250° F, and 5000' elevation.

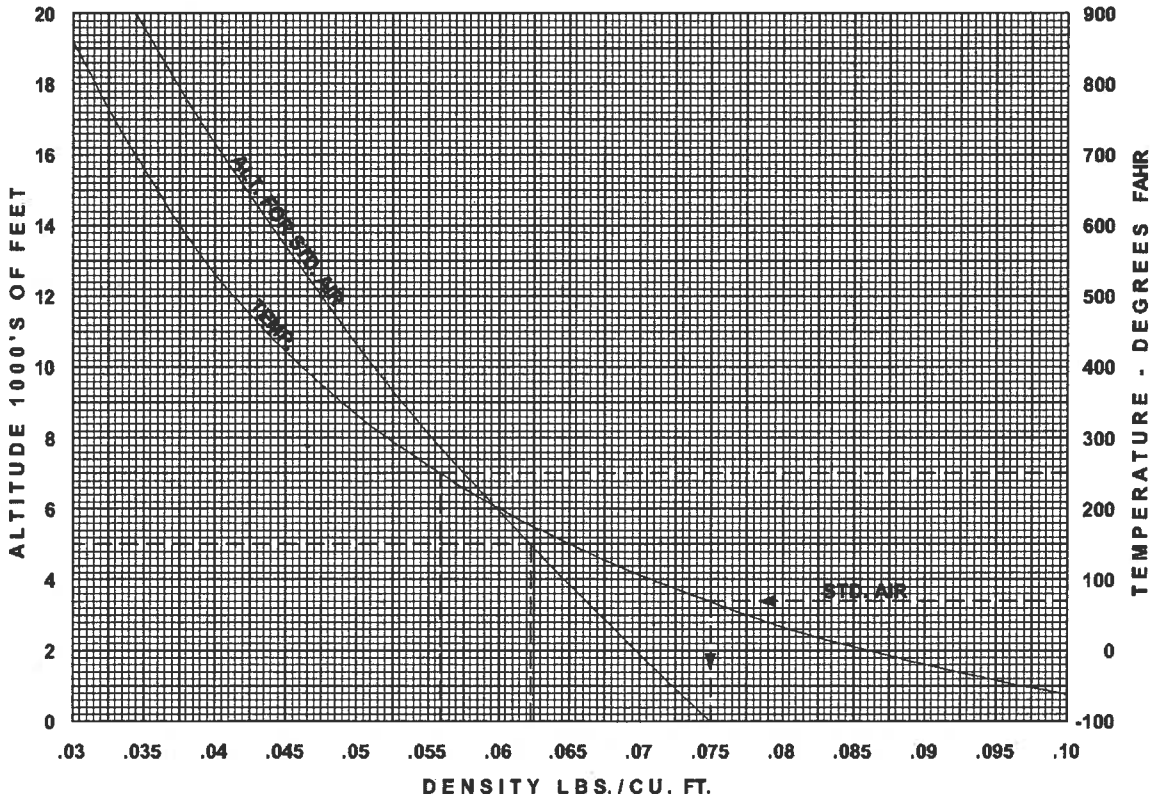



CI FAN Performance Chart

KCH Services certifies that the CI & NH Fans shown herein are licensed to bear the AMCA Seal. The ratings shown are based on tests and procedures performed in accordance with AMCA publication 211 and comply with the requirements of the AMCA Certified Ratings Program.

SIZE 6

KCH TYPE CI FAN

TYPE SS WHEEL

TIP SPEED = RPM x 2.749

MAX. RPM FOR ARR. 1,4,8 AND 9 = 5450

WHEEL DIAMETER = 10-1/2"

INLET AND OUTLET AREA = 0.205 SQ. FT.

Volume of Air CFM	Outlet Velocity FPM	1" SP		2" SP		3" SP		4" SP		5" SP		6" SP		7" SP		8" SP		9" SP	
		RPM	BHP	RPM	BHP	RPM	BHP	RPM	BHP	RPM	BHP	RPM	BHP	RPM	BHP	RPM	BHP	RPM	BHP
205	1000	1347	0.08	1840	0.16	2218	0.26	2542	0.38	2831	0.50	3107	0.64	3343	0.78	3572	0.93	3784	1.09
256	1250	1398	0.10	1878	0.19	2257	0.31	2573	0.43	2861	0.56	3123	0.70	3356	0.85	3592	1.01	3802	1.18
307	1500	1456	0.12	1922	0.23	2296	0.35	2610	0.48	2891	0.62	3156	0.78	3392	0.94	3606	1.10	3813	1.27
358	1750	1519	0.15	1973	0.27	2336	0.40	2651	0.54	2929	0.69	3190	0.86	3418	1.02	3642	1.20	3851	1.39
409	2000	1594	0.18	2031	0.31	2386	0.45	2695	0.61	2974	0.77	3225	0.94	3459	1.12	3681	1.31	3880	1.50
460	2250	1672	0.22	2092	0.37	2441	0.52	2742	0.68	3017	0.85	3262	1.03	3501	1.23	3712	1.42	3915	1.62
512	2500	1758	0.27	2157	0.43	2499	0.59	2797	0.76	3066	0.95	3306	1.13	3535	1.33	3757	1.55	3954	1.76
563	2750	1847	0.32	2228	0.49	2562	0.67	2854	0.85	3119	1.05	3358	1.25	3587	1.46	3795	1.67	3997	1.90
614	3000	1942	0.39	2307	0.57	2624	0.76	2913	0.95	3176	1.16	3409	1.37	3632	1.58	3843	1.81	4042	2.05
665	3250	2042	0.46	2387	0.65	2695	0.86	2974	1.06	3232	1.28	3467	1.50	3686	1.73	3894	1.97	4091	2.21
716	3500	2143	0.55	2473	0.75	2770	0.96	3038	1.18	3292	1.41	3530	1.65	3747	1.89	3946	2.13	4142	2.38
767	3750	2250	0.64	2561	0.85	2850	1.08	3109	1.31	3357	1.56	3586	1.80	3802	2.05	4007	2.31	4195	2.57
818	4000	2358	0.75	2653	0.97	2931	1.21	3187	1.46	3420	1.71	3649	1.97	3864	2.24	4063	2.50	4251	2.77
870	4250	2470	0.87	2749	1.10	3018	1.35	3264	1.61	3493	1.88	3712	2.15	3921	2.42	4119	2.70	4309	2.99
921	4500	2581	1.01	2849	1.25	3103	1.51	3344	1.78	3571	2.06	3780	2.34	3985	2.63	4185	2.93	4369	3.22
972	4750	2695	1.15	2949	1.41	3195	1.68	3428	1.96	3648	2.25	3855	2.54	4056	2.85	4245	3.15	4432	3.47
1023	5000	2812	1.32	3051	1.58	3289	1.86	3515	2.16	3730	2.46	3930	2.76	4128	3.08	4314	3.40	4497	3.73
1074	5250	2929	1.50	3157	1.77	3384	2.06	3603	2.37	3813	2.68	4011	3.00	4201	3.33	4385	3.66	4557	3.99
1125	5500	3048	1.70	3266	1.98	3482	2.28	3695	2.60	3900	2.93	4093	3.26	4276	3.59	4457	3.94	4627	4.28
1177	5750	3168	1.91	3376	2.21	3585	2.52	3787	2.84	3984	3.18	4176	3.52	4358	3.88	4531	4.23	4699	4.58
1228	6000	3287	2.14	3487	2.46	3685	2.77	3885	3.11	4073	3.45	4260	3.81	4442	4.18	4614	4.55	4781	4.92
1279	6250	3408	2.40	3600	2.72	3790	3.05	3984	3.39	4169	3.75	4351	4.12	4522	4.49	4693	4.88	4859	5.27
1330	6500	3527	2.66	3714	3.01	3900	3.35	4084	3.70	4261	4.06	4439	4.44	4609	4.83	4775	5.22	4933	5.61
1381	6750	3649	2.96	3830	3.31	4008	3.67	4186	4.03	4361	4.40	4529	4.78	4699	5.19	4859	5.59	5016	6.00
1432	7000	3774	3.27	3944	3.64	4114	4.00	4285	4.37	4457	4.76	4621	5.15	4786	5.56	4946	5.98	5103	6.41
1483	7250	3898	3.61	4061	3.99	4226	4.36	4392	4.75	4555	5.14	4721	5.55	4876	5.96	5035	6.40	5186	6.83
1535	7500	4021	3.97	4177	4.35	4337	4.74	4500	5.15	4656	5.54	4818	5.96	4968	6.38	5122	6.83	5273	7.28
1586	7750	4143	4.35	4295	4.75	4450	5.15	4607	5.56	4760	5.97	4912	6.39	5064	6.83	5212	7.28	5363	7.75

Volume of Air CFM	Outlet Velocity FPM	10" SP		11" SP		12" SP		13" SP		14" SP		15" SP		16" SP		17" SP		18" SP	
		RPM	BHP	RPM	BHP	RPM	BHP	RPM	BHP	RPM	BHP	RPM	BHP	RPM	BHP	RPM	BHP	RPM	BHP
205	1000	3995	1.27	4169	1.42	4359	1.61	4532	1.79	4718	2.01	4879	2.20	5051	2.43	5188	2.62	5332	2.83
256	1250	3992	1.35	4178	1.52	4383	1.73	4550	1.92	4730	2.13	4891	2.34	5029	2.52	5174	2.73	5328	2.96
307	1500	4028	1.47	4205	1.64	4399	1.85	4562	2.04	4738	2.26	4900	2.47	5043	2.67	5196	2.89	5358	3.15
358	1750	4054	1.58	4242	1.78	4410	1.97	4592	2.19	4744	2.39	4906	2.61	5080	2.86	5212	3.06	5379	3.33
409	2000	4073	1.70	4270	1.91	4436	2.11	4614	2.34	4787	2.57	4932	2.78	5085	3.01	5248	3.27	5396	3.52
460	2250	4115	1.84	4293	2.05	4471	2.27	4648	2.50	4804	2.73	4971	2.97	5129	3.22	5276	3.47	5408	3.70
512	2500	4148	1.98	4337	2.21	4514	2.44	4676	2.67	4850	2.93	5003	3.17	5146	3.40	5299	3.67	5439	3.92
563	2750	4188	2.13	4373	2.37	4550	2.61	4713	2.85	4874	3.10	5029	3.36	5195	3.64	5335	3.90	5484	4.18
614	3000	4231	2.29	4416	2.54	4593	2.80	4758	3.06	4921	3.32	5081	3.60	5220	3.85	5366	4.12	5521	4.43
665	3250	4279	2.46	4452	2.71	4629	2.98	4796	3.25	4962	3.53	5112	3.81	5271	4.11	5409	4.38	5554	4.68
716	3500	4320	2.63	4504	2.91	4672	3.18	4841	3.46	4998	3.74	5152	4.03	5301	4.33	5445	4.63	5597	4.95
767	3750	4374	2.83	4550	3.11	4720	3.39	4881	3.68	5041	3.98	5199	4.29	5341	4.58	5492	4.90	5635	5.22
818	4000	4431	3.05	4610	3.34	4773	3.63	4937	3.93	5091	4.23	5242	4.54	5390	4.85	5533	5.17	5669	5.49
870	4250	4491	3.28	4663	3.58	4830	3.88	4988	4.19	5135	4.48	5291	4.81	5433	5.13	5582	5.47	5713	5.79
921	4500	4546	3.52	4721	3.83	4882	4.14	5044	4.46	5196	4.78	5336	5.09	5483	5.43	5627	5.77	5765	6.12
972	4750	4612	3.79	4782	4.10	4938	4.41	5095	4.74	5252	5.09	5398	5.42	5541	5.76	5679	6.11	5813	6.45
1023	5000	4673	4.06	4838	4.38	4998	4.71	5160	5.06	5304	5.39	5455	5.75	5593	6.09	5728	6.44	5868	6.82
1074	5250	4729	4.33	4898	4.68	5063	5.03	5212	5.37	5370	5.74	5508	6.08	5652	6.46	5783	6.81	5919	7.18
1125	5500	4796	4.63	4962	4.99	5123	5.36	5277	5.72	5423	6.08	5566	6.45	5707	6.82	5845	7.20	5978	7.59
1177	5750	4866	4.95	5029	5.33	5187	5.71	5339	6.08	5481	6.44	5630	6.84	5768	7.22	5903	7.61	6032	7.99
1228	6000	4939	5.29	5092	5.67	5248	6.06	5396	6.44	5544	6.83	5691	7.24	5826	7.63	5967	8.05	6094	8.44
1279	6250	5015	5.65	5167	6.04	5320	6.45	5467	6.84	5612	7.25	5747	7.64	5889	8.07	6017	8.46	6152	8.89
1330	6500	5088	6.01	5245	6.44	5389	6.84	5533	7.25	5677	7.67	5809	8.07	5948	8.51	6084	8.94	6216	9.38
1381	6750	5170	6.42	5320	6.84	5462	7.25	5605	7.68	5746	8.12	5877	8.54	6014	8.98	6148	9.43	6277	9.87
1432	7000	5250	6.83	5398	7.27	5539	7.70	5681	8.14	5812	8.57	5950	9.03	6076	9.46	6208	9.91	6335	10.37
1483	7250	5332	7.27	5480	7.72	5621	8.17	5753	8.61	5892	9.07	6020	9.52	6153	10.00	6274	10.44	6400	10.90
1535	7500	5419	7.73	5559	8.18	5699	8.65	5830	9.10	5968	9.59	6095	10.04	6218	10.50	6347	10.99	6471	11.48
1586	7750	5503	8.21	5642	8.68	5782	9.16	5913	9.63	6041	10.10	6167	10.58	6298	11.08	6416	11.55	6539	12.05

All capacities based on standard air (density .075#/cu.ft. - 70 deg. F. - 29.92" Hg. Bar.). Values underlined indicate the most efficient point of operation for each pressure. Performance shown for installation type B & D - Free or ducted inlet, Ducted outlet. Performance ratings do not include the effects of appurtenances in the airstream. Power rating (BHP) does not include transmission losses.



CI FAN Performance Chart

KCH Services certifies that the CI & NH Fans shown herein are licensed to bear the AMCA Seal. The ratings shown are based on tests and procedures performed in accordance with AMCA publication 211 and comply with the requirements of the AMCA Certified Ratings Program.

SIZE 8

KCH TYPE CI FAN

TYPE SS WHEEL

TIP SPEED = RPM x 3.665

MAX. RPM FOR ARR. 1,4,8 AND 9 = 4100

WHEEL DIAMETER = 14

INLET AND OUTLET AREA = 0.349 SQ. FT.

Volume of Air CFM	Outlet Velocity FPM	1" SP		2" SP		3" SP		4" SP		5" SP		6" SP		7" SP		8" SP		9" SP	
		RPM	BHP	RPM	BHP	RPM	BHP	RPM	BHP	RPM	BHP	RPM	BHP	RPM	BHP	RPM	BHP	RPM	BHP
349	1000	976	0.11	1334	0.24	1615	0.38	1855	0.54	2065	0.70	2258	0.88	2434	1.07	2608	1.28	2757	1.48
436	1250	1006	0.15	1363	0.29	1637	0.45	1873	0.62	2080	0.80	2270	0.99	2443	1.19	2606	1.41	2765	1.63
524	1500	1046	0.18	1389	0.34	1665	0.52	1896	0.71	2103	0.91	2295	1.12	2468	1.34	2626	1.56	2782	1.81
611	1750	1097	0.23	1422	0.41	1693	0.60	1923	0.80	2126	1.02	2313	1.25	2486	1.49	2649	1.74	2795	1.98
698	2000	1154	0.28	1457	0.48	1721	0.69	1952	0.91	2154	1.14	2339	1.39	2514	1.65	2667	1.91	2822	2.19
785	2250	1218	0.35	1504	0.56	1756	0.79	1983	1.03	2186	1.28	2371	1.55	2536	1.81	2696	2.10	2844	2.39
873	2500	1285	0.43	1556	0.65	1794	0.90	2012	1.16	2212	1.43	2397	1.71	2566	2.00	2726	2.30	2870	2.60
960	2750	1355	0.52	1615	0.76	1840	1.02	2048	1.30	2243	1.59	2429	1.89	2597	2.20	2751	2.50	2898	2.82
1047	3000	1428	0.63	1676	0.89	1892	1.16	2091	1.45	2280	1.77	2456	2.08	2623	2.40	2779	2.73	2928	3.07
1134	3250	1504	0.75	1740	1.03	1948	1.32	2139	1.62	2321	1.95	2492	2.29	2655	2.63	2808	2.98	2960	3.34
1222	3500	1581	0.88	1808	1.19	2010	1.50	2194	1.82	2368	2.15	2533	2.51	2689	2.87	2844	3.25	2988	3.52
1309	3750	1662	1.03	1877	1.37	2074	1.70	2251	2.03	2417	2.37	2577	2.74	2727	3.12	2876	3.52	3019	3.92
1396	4000	1744	1.21	1948	1.57	2137	1.91	2309	2.26	2472	2.63	2625	3.00	2775	3.40	2914	3.80	3057	4.24
1484	4250	1827	1.40	2021	1.78	2203	2.15	2372	2.52	2530	2.90	2676	3.28	2823	3.70	2962	4.13	3096	4.56
1571	4500	1912	1.61	2096	2.01	2273	2.41	2437	2.80	2591	3.20	2735	3.60	2871	4.01	3007	4.45	3137	4.90
1658	4750	1999	1.85	2175	2.27	2342	2.69	2504	3.11	2654	3.53	2794	3.95	2928	4.37	3057	4.81	3184	5.27
1745	5000	2084	2.11	2254	2.55	2414	3.00	2570	3.44	2717	3.88	2856	4.32	2985	4.75	3113	5.21	3237	5.68
1833	5250	2172	2.40	2333	2.85	2488	3.32	2640	3.80	2784	4.26	2919	4.71	3047	5.17	3169	5.64	3292	6.13
1920	5500	2260	2.72	2415	3.19	2565	3.68	2709	4.17	2847	4.65	2982	5.13	3109	5.62	3230	6.11	3347	6.60
2007	5750	2350	3.06	2497	3.55	2642	4.06	2782	4.58	2918	5.09	3049	5.59	3172	6.09	3289	6.59	3405	7.10
2094	6000	2438	3.44	2583	3.94	2719	4.46	2856	5.01	2986	5.54	3114	6.07	3237	6.60	3353	7.12	3463	7.63
2182	6250	2528	3.84	2666	4.36	2801	4.91	2930	5.47	3058	6.03	3183	6.58	3302	7.13	3418	7.68	3528	8.22
2269	6500	2620	4.28	2752	4.82	2880	5.38	3008	5.97	3131	6.55	3253	7.13	3369	7.69	3481	8.25	3591	8.83
2356	6750	2710	4.76	2838	5.31	2964	5.89	3085	6.48	3206	7.10	3321	7.69	3437	8.29	3549	8.89	3655	9.47
2443	7000	2800	5.26	2924	5.82	3046	6.43	3163	7.04	3281	7.68	3394	8.30	3507	8.93	3615	9.54	3721	10.15
2531	7250	2892	5.80	3011	6.38	3130	7.01	3245	7.65	3355	8.28	3469	8.96	3575	9.58	3683	10.22	3789	10.87
2618	7500	2984	6.38	3100	6.99	3212	7.61	3323	8.26	3435	8.94	3542	9.62	3649	10.29	3754	10.95	3855	11.61
2705	7750	3075	7.00	3188	7.62	3297	8.26	3406	8.94	3512	9.62	3618	10.32	3721	11.02	3822	11.70	3924	12.39

Volume of Air CFM	Outlet Velocity FPM	10" SP		11" SP		12" SP		13" SP		14" SP		15" SP		16" SP		17" SP		18" SP	
		RPM	BHP	RPM	BHP	RPM	BHP	RPM	BHP	RPM	BHP	RPM	BHP	RPM	BHP	RPM	BHP	RPM	BHP
349	1000	2903	1.70	3045	1.93	3178	2.16	3323	2.44	3427	2.65	3567	2.95	3672	3.19				
436	1250	2912	1.87	3059	2.12	3184	2.36	3320	2.63	3446	2.90	3558	3.15	3678	3.44	3780	3.70	3888	3.99
524	1500	2932	2.06	3069	2.31	3204	2.58	3318	2.82	3440	3.10	3571	3.41	3692	3.72	3799	4.01	3913	4.33
611	1750	2946	2.25	3076	2.51	3219	2.81	3345	3.10	3467	3.39	3581	3.68	3702	4.00	3813	4.31	3911	4.60
698	2000	2966	2.47	3103	2.75	3230	3.04	3354	3.33	3474	3.64	3588	3.94	3710	4.28	3823	4.62	3927	4.94
785	2250	2982	2.68	3125	2.99	3249	3.29	3371	3.60	3491	3.92	3607	4.25	3730	4.61	3832	4.93	3939	5.28
873	2500	3012	2.92	3151	3.25	3274	3.57	3396	3.89	3517	4.24	3634	4.59	3746	4.94	3852	5.29	3964	5.67
960	2750	3037	3.15	3173	3.50	3304	3.86	3427	4.21	3538	4.55	3656	4.92	3771	5.30	3881	5.68	3984	6.05
1047	3000	3072	3.43	3200	3.77	3330	4.14	3453	4.52	3565	4.88	3686	5.28	3792	5.66	3905	6.07	4001	6.44
1134	3250	3096	3.70	3229	4.07	3359	4.46	3483	4.85	3598	5.24	3711	5.64	3821	6.04	3927	6.45	4027	6.85
1222	3500	3129	4.01	3263	4.40	3385	4.78	3510	5.19	3626	5.60	3742	6.02	3845	6.42	3955	6.87	4060	7.31
1309	3750	3158	4.32	3285	4.72	3415	5.14	3541	5.57	3652	5.97	3769	6.41	3876	6.85	3980	7.28	4089	7.76
1396	4000	3191	4.66	3318	5.07	3442	5.50	3569	5.96	3681	6.38	3793	6.82	3904	7.28	4011	7.74	4115	8.22
1484	4250	3225	5.01	3353	5.45	3472	5.89	3593	6.35	3708	6.80	3823	7.28	3936	7.76	4039	8.22	4148	8.73
1571	4500	3267	5.37	3388	5.84	3512	6.32	3629	6.79	3740	7.26	3857	7.77	3966	8.26	4073	8.76	4168	9.22
1658	4750	3311	5.76	3431	6.25	3549	6.75	3662	7.23	3775	7.74	3888	8.25	3993	8.75	4096	9.25	4203	9.80
1745	5000	3357	6.17	3474	6.67	3588	7.18	3701	7.70	3814	8.24	3917	8.74	4025	9.28	4132	9.83	4228	10.34
1833	5250	3409	6.62	3519	7.11	3636	7.67	3743	8.19	3850	8.73	3956	9.29	4061	9.84	4165	10.40	4256	10.96
1920	5500	3458	7.09	3571	7.61	3681	8.15	3791	8.72	3896	9.28	4000	9.85	4095	10.39	4195	10.97	4293	11.54
2007	5750	3514	7.61	3626	8.15	3734	8.70	3836	9.25	3939	9.82	4040	10.41	4140	11.00	4238	11.60	4333	12.20
2094	6000	3577	8.19	3683	8.73	3784	9.26	3885	9.82	3985	10.40	4084	11.00	4182	11.61	4278	12.22	4371	12.83
2182	6250	3637	8.78	3741	9.34	3841	9.89	3941	10.47	4040	11.06	4138	11.68	4228	12.26	4322	12.89	4420	13.56
2269	6500	3698	9.41	3797	9.96	3896	10.54	3995	11.13	4093	11.73	4190	12.36	4278	12.95	4370	13.60	4467	14.29
2356	6750	3762	10.07	3861	10.65	3959	11.25	4052	11.83	4149	12.46	4238	13.06	4322	13.70	4423	14.36	4511	15.02
2443	7000	3823	10.76	3921	11.36	4019	11.99	4111	12.59	4208	13.24	4296	13.85	4389	14.52	4472	15.13	4559	15.80
2531	7250	3887	11.48	3990	12.15	4082	12.76	4174	13.39	4264	14.03	4358	14.71	4443	15.35	4526	15.98	4612	16.65
2618	7500	3953	12.25	4051	12.91	4148	13.59	4240	14.25	4329	14.91	4417	15.57	4502	16.23	4584	16.88	4689	17.58
2705	7750	4022	13.07	4115	13.73	4212	14.44	4303	15.12	4387	15.77	4474	16.45	4558	17.13	4646	17.86	4723	18.52

All capacities based on standard air (density .075#/cu.ft. - 70 deg. F. - 29.92" Hg. Bar.). Values underlined indicate the most efficient point of operation for each pressure. Performance shown for installation type B & D - Free or ducted inlet, Ducted outlet. Performance ratings do not include the effects of appurtenances in the airstream. Power rating (BHP) does not include transmission losses.



CI FAN Performance Chart

KCH Services certifies that the CI & NH Fans shown herein are licensed to bear the AMCA Seal. The ratings shown are based on tests and procedures performed in accordance with AMCA publication 211 and comply with the requirements of the AMCA Certified Ratings Program.

SIZE 10

KCH TYPE CI FAN

TYPE SS WHEEL

TIP SPEED = RPM x 4.58

MAX. RPM FOR ARR. 1,4,8 AND 9 = 3600

WHEEL DIAMETER = 17-1/2"

INLET AND OUTLET AREA = 0.559 SQ. FT.

Volume of Air CFM	Outlet Velocity FPM	1" SP		2" SP		3" SP		4" SP		5" SP		6" SP		7" SP		8" SP		9" SP	
		RPM	BHP	RPM	BHP	RPM	BHP	RPM	BHP	RPM	BHP	RPM	BHP	RPM	BHP	RPM	BHP	RPM	BHP
559	1000	783	0.18	1070	0.38	1294	0.60	1485	0.85	1653	1.11	1807	1.40	1950	1.70	2080	2.01	2208	2.35
699	1250	808	0.23	1093	0.46	1312	0.71	1501	0.98	1666	1.27	1818	1.58	1962	1.90	2090	2.24	2214	2.59
839	1500	842	0.29	1116	0.55	1336	0.83	1521	1.13	1686	1.45	1835	1.78	1974	2.12	2105	2.49	2227	2.86
978	1750	885	0.37	1141	0.65	1359	0.96	1543	1.28	1707	1.63	1856	2.00	1992	2.37	2120	2.75	2241	3.15
1118	2000	934	0.46	1174	0.77	1382	1.11	1567	1.46	1729	1.83	1877	2.22	2014	2.63	2140	3.05	2262	3.48
1258	2250	987	0.57	1212	0.90	1411	1.27	1590	1.65	1753	2.05	1900	2.47	2036	2.90	2162	3.35	2281	3.81
1398	2500	1042	0.71	1256	1.06	1445	1.45	1617	1.87	1777	2.30	1925	2.74	2060	3.20	2185	3.67	2303	4.15
1538	2750	1099	0.86	1305	1.24	1484	1.65	1648	2.09	1803	2.56	1947	3.03	2083	3.52	2210	4.02	2327	4.53
1677	3000	1161	1.03	1357	1.46	1528	1.88	1685	2.35	1833	2.84	1974	3.35	2106	3.86	2233	4.39	2350	4.92
1817	3250	1224	1.23	1410	1.69	1576	2.15	1725	2.62	1868	3.14	2003	3.68	2133	4.23	2257	4.79	2374	5.36
1957	3500	1288	1.46	1466	1.96	1625	2.45	1770	2.95	1907	3.48	2037	4.04	2162	4.63	2282	5.22	2398	5.81
2097	3750	1355	1.71	1522	2.25	1678	2.78	1818	3.30	1950	3.85	2075	4.43	2197	5.05	2313	5.67	2425	6.30
2237	4000	1422	2.00	1582	2.58	1732	3.14	1868	3.70	1996	4.27	2117	4.86	2234	5.49	2348	6.15	2456	6.82
2376	4250	1491	2.32	1642	2.93	1786	3.53	1920	4.13	2044	4.73	2161	5.34	2274	5.98	2385	6.66	2490	7.35
2516	4500	1561	2.69	1706	3.32	1843	3.97	1973	4.60	2095	5.23	2208	5.86	2318	6.52	2424	7.21	2527	7.92
2656	4750	1632	3.09	1770	3.75	1901	4.43	2028	5.10	2147	5.77	2258	6.44	2365	7.12	2466	7.80	2567	8.53
2796	5000	1703	3.53	1835	4.22	1962	4.94	2084	5.65	2200	6.35	2310	7.05	2412	7.75	2512	8.47	2609	9.20
2935	5250	1776	4.01	1902	4.73	2023	5.49	2141	6.23	2254	6.97	2361	7.71	2463	8.45	2561	9.19	2655	9.94
3075	5500	1848	4.54	1969	5.29	2086	6.07	2199	6.86	2310	7.64	2415	8.41	2515	9.18	2610	9.95	2703	10.74
3215	5750	1921	5.12	2037	5.90	2150	6.71	2260	7.55	2366	8.36	2468	9.16	2568	9.98	2661	10.77	2752	11.58
3355	6000	1995	5.75	2106	6.55	2215	7.39	2321	8.26	2423	9.11	2524	9.96	2621	10.81	2714	11.64	2802	12.48
3495	6250	2069	6.43	2176	7.26	2281	8.13	2383	9.03	2484	9.93	2581	10.81	2675	11.69	2766	12.56	2854	13.44
3634	6500	2143	7.17	2246	8.02	2347	8.91	2447	9.85	2543	10.79	2638	11.71	2730	12.62	2821	13.54	2907	14.45
3774	6750	2217	7.96	2317	8.84	2415	9.77	2511	10.72	2604	11.69	2697	12.67	2787	13.62	2875	14.57	2960	15.51
3914	7000	2292	8.81	2388	9.71	2483	10.66	2576	11.65	2668	12.66	2757	13.68	2845	14.67	2931	15.66	3014	16.63
4054	7250	2367	9.72	2460	10.65	2552	11.63	2642	12.64	2731	13.69	2818	14.74	2903	15.77	2987	16.79	3070	17.82
4194	7500	2442	10.70	2533	11.66	2621	12.65	2710	13.71	2796	14.78	2880	15.85	2964	16.95	3044	17.99	3126	19.06
4333	7750	2518	11.74	2605	12.72	2691	13.75	2776	14.82	2861	15.93	2942	17.03	3024	18.17	3104	19.27	3182	20.36

Volume of Air CFM	Outlet Velocity FPM	10" SP		11" SP		12" SP		13" SP		14" SP		15" SP		16" SP		17" SP		18" SP	
		RPM	BHP	RPM	BHP	RPM	BHP	RPM	BHP	RPM	BHP	RPM	BHP	RPM	BHP	RPM	BHP	RPM	BHP
559	1000	2323	2.68	2438	3.05	2546	3.42	2650	3.81	2751	4.21	2850	4.63	2944	5.05	3031	5.47		
699	1250	2330	2.95	2444	3.34	2548	3.72	2654	4.14	2752	4.55	2848	4.98	2942	5.42	3032	5.87	3116	6.32
839	1500	2344	3.26	2451	3.64	2562	4.08	2664	4.50	2760	4.93	2855	5.38	2949	5.85	3032	6.29	3120	6.77
978	1750	2359	3.58	2466	3.99	2572	4.43	2671	4.87	2771	5.34	2866	5.82	2954	6.28	3047	6.80	3131	7.29
1118	2000	2374	3.91	2481	4.36	2589	4.83	2686	5.29	2785	5.79	2880	6.29	2970	6.79	3059	7.31	3146	7.84
1258	2250	2393	4.27	2501	4.75	2606	5.25	2707	5.75	2801	6.25	2891	6.76	2982	7.29	3073	7.86	3158	8.40
1398	2500	2415	4.65	2524	5.17	2624	5.68	2724	6.21	2818	6.74	2910	7.29	3003	7.86	3088	8.42	3173	8.99
1538	2750	2440	5.06	2544	5.58	2646	6.13	2746	6.70	2841	7.27	2929	7.83	3019	8.46	3105	9.01	3191	9.62
1677	3000	2463	5.48	2569	6.04	2671	6.62	2768	7.20	2864	7.81	2954	8.41	3042	9.03	3126	9.64	3210	10.28
1817	3250	2486	5.94	2594	6.53	2693	7.11	2790	7.73	2887	8.37	2975	8.99	3065	9.65	3148	10.29	3231	10.95
1957	3500	2508	6.42	2616	7.04	2718	7.67	2815	8.30	2910	8.96	3001	9.62	3086	10.27	3172	10.96	3254	11.65
2097	3750	2535	6.94	2640	7.59	2740	8.23	2838	8.90	2934	9.59	3023	10.26	3111	10.96	3196	11.67	3278	12.38
2237	4000	2562	7.48	2664	8.16	2764	8.84	2861	9.54	2955	10.25	3047	10.96	3133	11.67	3221	12.42	3303	13.16
2376	4250	2592	8.05	2693	8.77	2792	9.49	2887	10.21	2980	10.95	3070	11.70	3156	12.43	3244	13.21	3325	13.96
2516	4500	2628	8.66	2726	9.41	2821	10.17	2913	10.91	3005	11.68	3095	12.46	3180	13.23	3264	14.01	3349	14.82
2656	4750	2665	9.29	2761	10.07	2853	10.85	2945	11.66	3034	12.45	3120	13.25	3205	14.05	3289	14.87	3370	15.69
2796	5000	2706	9.99	2799	10.78	2889	11.59	2978	12.42	3065	13.26	3149	14.08	3234	14.93	3318	15.80	3396	16.63
2935	5250	2748	10.72	2839	11.54	2928	12.37	3014	13.22	3099	14.08	3183	14.97	3263	15.84	3344	16.72	3423	17.60
3075	5500	2793	11.53	2881	12.35	2968	13.20	3053	14.08	3135	14.96	3217	15.86	3295	16.75	3374	17.68	3454	18.63
3215	5750	2839	12.40	2926	13.24	3010	14.09	3093	14.98	3174	15.89	3255	16.81	3334	17.76	3408	18.68	3486	19.66
3355	6000	2889	13.33	2973	14.19	3056	15.07	3136	15.95	3216	16.88	3292	17.80	3369	18.77	3445	19.74	3521	20.75
3495	6250	2938	14.31	3022	15.20	3101	16.09	3181	17.00	3257	17.92	3335	18.88	3408	19.84	3483	20.84	3557	21.87
3634	6500	2991	15.37	3072	16.28	3151	17.20	3226	18.13	3303	19.07	3377	20.02	3450	20.99	3523	22.01	3597	23.07
3774	6750	3044	16.47	3122	17.40	3201	18.36	3277	19.32	3349	20.27	3423	21.25	3495	22.25	3567	23.28	3637	24.32
3914	7000	3096	17.62	3174	18.59	3250	19.57	3326	20.57	3398	21.55	3471	22.57	3540	23.56	3611	24.61	3677	25.62
4054	7250	3150	18.84	3228	19.86	3302	20.86	3375	21.87	3447	22.89	3519	23.94	3588	24.96	3656	26.01	3724	27.09
4194	7500	3204	20.11	3281	21.16	3356	22.22	3427	23.25	3499	24.31	3568	25.37	3636	26.43	3704	27.51	3769	28.58
4333	7750	3259	21.44	3335	22.54	3409	23.63	3481	24.72	3550	25.79	3620	26.90	3685	27.96	3752	29.07	3816	30.17

All capacities based on standard air (density .075#/cu.ft. - 70 deg. F. - 29.92" Hg. Bar.). Values underlined indicate the most efficient point of operation for each pressure. Performance shown for installation type B & D - Free or ducted inlet, Ducted outlet. Performance ratings do not include the effects of appurtenances in the airstream. Power rating (BHP) does not include transmission losses.

SIZE 12-1/4

SINGLE WIDTH
SINGLE INLET

KCH TYPE NH FANS

NON-OVERLOADING MEDIUM SPEED HIGH EFFICIENCY

CLASSES

II AND III

Outlet Size 9-3/4" x 12-3/4" I.D.

Wheel Diameter 12-1/4 In.

Inlet Size 13-1/4" I.D.

Outlet Area .863 Sq. Ft. Inside

Tip Speed = RPM x 3.21

Max. BHP = .07



KCH Services certifies that the CI & NH Fans shown herein are licensed to bear the AMCA Seal. The ratings shown are based on tests and procedures performed in accordance with AMCA publication 211 and comply with the requirements of the AMCA Certified Ratings Program.

Volume of Air CFM	Outlet Velocity FPM	1/2" SP		1" SP		1-1/2" SP		2" SP		2-1/2" SP		3" SP		3-1/2" SP		4" SP		4-1/2" SP		5" SP	
		RPM	BHP	RPM	BHP	RPM	BHP	RPM	BHP	RPM	BHP	RPM	BHP	RPM	BHP	RPM	BHP	RPM	BHP	RPM	BHP
604	700	1111	0.09	1360	0.16	1615	0.25														
691	800	1195	0.11	1422	0.19	1639	0.28			1863	0.39										
777	900	1281	0.14	1497	0.22	1690	0.31			1884	0.42	2084	0.54								
863	1000	1370	0.16	1580	0.26	1756	0.35			1930	0.46	2104	0.58	2283	0.72						
950	1100	1462	0.20	1663	0.30	1833	0.40	1989	0.51		2148	0.63	2305	0.77	2466	0.91					
1036	1200	1557	0.24	1748	0.35	1913	0.46	2061	0.57		2206	0.69	2350	0.83	2493	0.97	2641	1.13	2794	1.30	
1122	1300	1654	0.28	1834	0.40	1998	0.52	2139	0.64		2273	0.77	2407	0.90	2541	1.05	2674	1.20	2809	1.37	2948
1209	1400	1752	0.33	1924	0.46	2082	0.59	2222	0.72		2350	0.85	2474	0.99	2597	1.13	2721	1.29	2844	1.45	2971
1285	1500	1851	0.39	2014	0.52	2167	0.66	2306	0.80		2430	0.94	2548	1.08	2662	1.23	2778	1.38	2895	1.55	3011
1381	1600	1951	0.45	2109	0.59	2254	0.74	2390	0.89		2513	1.04	2626	1.19	2736	1.34	2845	1.50	2952	1.66	3062
1468	1700	2051	0.52	2205	0.67	2343	0.82	2475	0.98		2597	1.14	2709	1.30	2814	1.46	2917	1.62	3017	1.79	3119
1554	1800	2151	0.60	2302	0.76	2434	0.92	2581	1.08		2681	1.25	2793	1.42	2896	1.59	2994	1.76	3091	1.93	3186
1640	1900	2253	0.69	2399	0.86	2526	1.02	2649	1.19		2766	1.37	2877	1.55	2979	1.73	3076	1.91	3168	2.08	3260
1727	2000	2355	0.78	2497	0.96	2623	1.14	2739	1.31		2852	1.50	2961	1.69	3063	1.88	3159	2.06	3248	2.24	3338
1813	2100	2457	0.88	2596	1.07	2718	1.26	2830	1.44		2940	1.63	3046	1.83	3146	2.03	3243	2.23	3333	2.42	3419
1899	2200	2559	1.00	2697	1.20	2815	1.39	2923	1.58		3029	1.78	3133	1.98	3231	2.19	3326	2.40	3416	2.60	3500
1986	2300	2662	1.12	2795	1.33	2912	1.53	3018	1.73		3120	1.93	3220	2.15	3317	2.36	3410	2.58	3501	2.80	3585
2072	2400	2765	1.25	2896	1.47	3010	1.68	3115	1.89		3212	2.10	3309	2.32	3405	2.55	3497	2.77	3585	3.00	3670
2158	2500	2867	1.39	2997	1.62	3108	1.85	3211	2.07		3307	2.28	3401	2.51	3493	2.74	3583	2.97	3689	3.21	3754
2245	2600	2971	1.54	3098	1.79	3209	2.02	3308	2.25		3403	2.48	3492	2.70	3583	2.94	3668	3.18	3755	3.43	3838
2331	2700	3073	1.70	3200	1.97	3308	2.21	3405	2.44		3497	2.68	3585	2.91	3673	3.16	3757	3.40	3842	3.66	3922
2417	2800	3178	1.88	3301	2.15	3407	2.41	3505	2.66		3594	2.90	3682	3.14	3763	3.38	3848	3.64	3928	3.90	4010
2504	2900	3282	2.07	3403	2.35	3508	2.62	3603	2.87		3692	3.13	3776	3.38	3858	3.63	3937	3.89	4018	4.16	4097
2590	3000	3386	2.27	3504	2.56	3609	2.84	3702	3.11		3791	3.37	3873	3.63	3952	3.89	4029	4.15	4109	4.43	4186

Volume of Air CFM	Outlet Velocity FPM	5-1/2" SP		6" SP		6-1/2" SP		7" SP		7-1/2" SP		8" SP		9" SP		10" SP		11" SP		12" SP	
		RPM	BHP	RPM	BHP	RPM	BHP	RPM	BHP	RPM	BHP	RPM	BHP	RPM	BHP	RPM	BHP	RPM	BHP	RPM	BHP
1122	1300	3091	1.75																		
1209	1400	3098	1.82	3230	2.02																
1295	1500	3127	1.91	3241	2.10	3364	2.32	3489	2.54												
1381	1600	3171	2.03	3277	2.22	3388	2.42	3498	2.63	3612	2.86	3725	3.09								
1468	1700	3222	2.15	3326	2.35	3426	2.54	3529	2.75	3630	2.97	3737	3.20	3954	3.69						
1554	1800	3282	2.29	3380	2.49	3478	2.69	3574	2.90	3668	3.11	3768	3.34	3962	3.81	4167	4.33				
1640	1900	3352	2.45	3442	2.64	3535	2.85	3625	3.06	3717	3.28	3810	3.50	3969	3.96	4177	4.47	4373	5.02		
1727	2000	3426	2.63	3513	2.82	3598	3.02	3683	3.23	3773	3.46	3860	3.68	4031	4.14	4208	4.65	4383	5.17	4567	5.74
1813	2100	3504	2.81	3588	3.02	3669	3.22	3751	3.43	3832	3.64	3914	3.87	4081	4.34	4245	4.84	4414	5.37	4579	5.91
1899	2200	3585	3.02	3665	3.22	3743	3.43	3824	3.65	3901	3.86	3979	4.08	4137	4.56	4296	5.06	4452	5.57	4610	6.12
1986	2300	3665	3.22	3745	3.44	3822	3.65	3900	3.88	3974	4.09	4050	4.33	4197	4.79	4352	5.30	4500	5.81	4654	6.37
2072	2400	3750	3.45	3827	3.67	3901	3.89	3975	4.11	4049	4.34	4121	4.57	4267	5.05	4412	5.55	4554	6.07	4700	6.82
2158	2500	3834	3.68	3912	3.91	3983	4.14	4057	4.37	4127	4.60	4200	4.84	4338	5.32	4477	5.83	4613	6.34	4752	6.99
2245	2600	3919	3.92	3997	4.17	4068	4.40	4139	4.64	4209	4.88	4278	5.12	4416	5.63	4547	6.12	4677	6.64	4815	7.21
2331	2700	4000	4.16	4079	4.42	4154	4.68	4225	4.93	4292	5.17	4361	5.43	4491	5.92	4621	6.44	4750	6.96	4874	7.51
2417	2800	4088	4.43	4164	4.70	4236	4.96	4308	5.22	4378	5.49	4444	5.74	4574	6.26	4700	6.79	4825	7.33	4948	7.88
2504	2900	4174	4.70	4247	4.97	4319	5.24	4391	5.52	4461	5.80	4527	6.07	4654	6.60	4780	7.15	4900	7.69	5019	8.24
2590	3000	4260	4.98	4333	5.26	4406	5.55	4475	5.83	4548	6.12	4612	6.40	4739	6.96	4861	7.52	4977	8.07	5095	8.64
2676	3100	4349	5.29	4420	5.57	4490	5.86	4559	6.15	4627	6.45	4694	6.74	4821	7.32	4943	7.90	5060	8.48	5173	9.05
2762	3200	4437	5.60	4506	5.90	4579	6.20	4645	6.49	4713	6.80	4780	7.11	4908	7.72	5027	8.31	5139	8.88	5253	9.48
2849	3300	4526	5.92	4598	6.24	4668	6.54	4732	6.85	4797	7.15	4864	7.48	4989	8.09	5112	8.73	5225	9.33	5334	9.93
2935	3400	4619	6.28	4685	6.58	4754	6.90	4821	7.22	4886	7.54	4950	7.86	5075	8.51	5195	9.15	5308	9.77	5417	10.40
3021	3500	4710	6.63	4777	6.95	4843	7.27	4907	7.59	4973	7.93	5034	8.25	5159	8.92	5279	9.59	5383	10.24	5502	10.89
3108	3600	4803	7.01	4867	7.33	4934	7.67	4998	7.99	5068	8.32	5122	8.67	5245	9.35	5362	10.03	5476	10.71	5585	11.38

All Capacities Based on Standard Air (Density .075#/cu.ft. - 70 deg. F. - 29.92" Hg. Bar.)

NOTES: (1) These ratings cover the performance of BOTH Class II and Class III Type NH Fans. Class II Fans can be used for ratings printed in white areas ONLY. Class III Fans can be used for ALL ratings printed in white and grey areas. (2) Ball bearings are standard on all Type NH Fans. (3) Values underlined indicate the most efficient point of operation for each pressure. (4) Performance shown is for installation type B & D - Free or ducted Inlet, Ducted outlet. (5) Performance ratings do not include the effects of appurtenances in the airstream. (6) Power rating (BHP) does not include transmission losses.

SIZE 13-1/2

SINGLE WIDTH
SINGLE INLET

KCH TYPE NH FANS

NON-OVERLOADING MEDIUM SPEED HIGH EFFICIENCY

CLASSES

II AND III

Outlet Size 10-3/4" x 14" I.D.

Wheel Diameter 13-1/2 in.

Inlet Size 14-5/8" I.D.

Outlet Area 1.045 Sq. Ft. Inside

Tip Speed = RPM x 3.54

Max. BHP = .11



KCH Services certifies that the CI & NH Fans shown herein are licensed to bear the AMCA Seal. The ratings shown are based on tests and procedures performed in accordance with AMCA publication 211 and comply with the requirements of the AMCA Certified Ratings Program.



Volume of Air CFM	Outlet Velocity FPM	1/2" SP		1" SP		1-1/2" SP		2" SP		2-1/2" SP		3" SP		3-1/2" SP		4" SP		4-1/2" SP		5" SP	
		RPM	BHP	RPM	BHP	RPM	BHP	RPM	BHP	RPM	BHP	RPM	BHP	RPM	BHP	RPM	BHP	RPM	BHP	RPM	BHP
732	700	1006	0.11	1234	0.20	1464	0.31														
836	800	1082	0.13	1289	0.23	1487	0.34	1691	0.47												
940	900	1160	0.16	1357	0.27	1531	0.38	1707	0.51	1891	0.66										
1045	1000	1239	0.20	1431	0.31	1591	0.43	1749	0.56	1907	0.70	2072	0.87								
1150	1100	1324	0.24	1506	0.36	1660	0.49	1802	0.62	1946	0.76	2091	0.93	2239	1.11						
1254	1200	1409	0.29	1584	0.42	1733	0.55	1867	0.69	1999	0.84	2130	1.00	2262	1.18	2396	1.37	2536	1.58		
1358	1300	1497	0.34	1661	0.48	1810	0.63	1938	0.77	2060	0.93	2181	1.09	2303	1.27	2426	1.46	2546	1.66	2676	1.88
1463	1400	1586	0.40	1742	0.55	1886	0.71	2013	0.87	2129	1.03	2241	1.19	2353	1.37	2468	1.56	2560	1.76	2692	1.97
1568	1500	1675	0.47	1824	0.63	1962	0.80	2089	0.97	2202	1.14	2308	1.31	2412	1.48	2517	1.67	2624	1.88	2729	2.09
1672	1600	1765	0.54	1910	0.71	2042	0.89	2165	1.07	2277	1.25	2379	1.43	2479	1.62	2578	1.81	2675	2.01	2774	2.23
1776	1700	1856	0.63	1995	0.81	2122	0.99	2242	1.19	2353	1.38	2454	1.57	2549	1.76	2643	1.96	2736	2.17	2829	2.38
1881	1800	1947	0.72	2063	0.92	2204	1.11	2320	1.31	2428	1.51	2530	1.72	2623	1.92	2714	2.13	2800	2.33	2890	2.55
1986	1900	2039	0.83	2171	1.03	2288	1.23	2399	1.44	2505	1.66	2606	1.88	2697	2.09	2787	2.30	2872	2.52	2956	2.74
2090	2000	2130	0.94	2260	1.16	2374	1.37	2479	1.58	2583	1.81	2682	2.04	2774	2.27	2862	2.49	2943	2.71	3024	2.94
2194	2100	2222	1.06	2350	1.29	2460	1.52	2563	1.74	2663	1.97	2759	2.21	2850	2.45	2938	2.69	3019	2.93	3097	3.16
2299	2200	2315	1.20	2440	1.44	2548	1.67	2647	1.91	2744	2.15	2837	2.40	2926	2.65	3013	2.90	3094	3.15	3170	3.39
2404	2300	2409	1.35	2530	1.60	2635	1.84	2733	2.09	2826	2.34	2916	2.59	3005	2.85	3089	3.12	3171	3.38	3247	3.64
2508	2400	2500	1.50	2621	1.77	2724	2.03	2819	2.28	2909	2.54	2997	2.80	3082	3.07	3167	3.35	3247	3.62	3324	3.90
2612	2500	2594	1.62	2712	1.96	2814	2.23	2906	2.49	2994	2.76	3078	3.02	3163	3.31	3245	3.59	3323	3.87	3400	4.16
2717	2600	2687	1.86	2804	2.16	2904	2.44	2994	2.71	3080	2.99	3162	3.26	3243	3.55	3322	3.84	3401	4.14	3476	4.44
2822	2700	2781	2.05	2894	2.36	2993	2.66	3084	2.95	3167	3.23	3247	3.52	3324	3.81	3402	4.11	3480	4.42	3553	4.72
2926	2800	2874	2.26	2987	2.59	3083	2.90	3172	3.20	3253	3.49	3332	3.79	3408	4.09	3485	4.40	3558	4.71	3632	5.03
3030	2900	2969	2.49	3080	2.83	3174	3.15	3261	3.46	3341	3.77	3419	4.08	3492	4.38	3565	4.69	3639	5.02	3708	5.34
3135	3000	3062	2.73	3171	3.09	3266	3.43	3350	3.75	3430	4.07	3506	4.38	3578	4.70	3649	5.01	3718	5.34	3788	5.67

Volume of Air CFM	Outlet Velocity FPM	5-1/2" SP		6" SP		6-1/2" SP		7" SP		7-1/2" SP		8" SP		9" SP		10" SP		11" SP		12" SP	
		RPM	BHP	RPM	BHP	RPM	BHP	RPM	BHP	RPM	BHP	RPM	BHP	RPM	BHP	RPM	BHP	RPM	BHP	RPM	BHP
1358	1300	2803	2.11																		
1463	1400	2808	2.20	2928	2.45																
1568	1500	2834	2.31	2941	2.55	3053	2.81	3162	3.07												
1672	1600	2873	2.45	2973	2.69	3070	2.93	3171	3.18	3276	3.47	3381	3.75								
1776	1700	2921	2.60	3014	2.84	3108	3.08	3201	3.34	3294	3.60	3391	3.88	3588	4.48						
1881	1800	2976	2.77	3063	3.01	3151	3.25	3239	3.51	3326	3.77	3415	4.04	3595	4.62	3782	5.26				
1986	1900	3037	2.96	3119	3.20	3203	3.45	3285	3.70	3369	3.96	3453	4.24	3619	4.81	3790	5.42	3967	6.09		
2090	2000	3104	3.17	3182	3.41	3260	3.65	3340	3.92	3419	4.18	3498	4.45	3656	5.02	3814	5.62	3977	6.27	4146	6.97
2194	2100	3175	3.40	3250	3.65	3324	3.89	3398	4.14	3472	4.41	3550	4.69	3701	5.26	3851	5.86	4000	6.49	4163	7.16
2299	2200	3248	3.64	3320	3.89	3391	4.14	3464	4.41	3535	4.67	3605	4.94	3750	5.52	3893	6.12	4038	6.76	4182	7.42
2404	2300	3320	3.89	3392	4.15	3463	4.41	3533	4.68	3600	4.95	3669	5.23	3807	5.80	3943	6.40	4082	7.05	4218	7.70
2508	2400	3396	4.16	3467	4.43	3534	4.70	3604	4.98	3669	5.25	3734	5.52	3866	6.11	3998	6.71	4130	7.35	4269	8.00
2612	2500	3473	4.45	3544	4.73	3608	5.00	3675	5.28	3742	5.57	3805	5.85	3930	6.43	4056	7.04	4183	7.69	4310	8.36
2717	2600	3550	4.74	3620	5.04	3685	5.32	3750	5.61	3813	5.90	3876	6.19	4001	6.80	4119	7.40	4241	8.05	4363	8.71
2822	2700	3623	5.03	3694	5.34	3762	5.65	3827	5.96	3888	6.25	3950	6.56	4072	7.18	4186	7.79	4304	8.43	4420	9.10
2926	2800	3700	5.34	3772	5.67	3837	5.99	3902	6.31	3963	6.61	4025	6.94	4143	7.57	4258	8.20	4371	8.86	4483	9.53
3030	2900	3780	5.68	3846	6.00	3912	6.33	3977	6.67	4041	7.01	4101	7.33	4218	7.97	4330	8.63	4440	9.29	4547	9.96
3135	3000	3858	6.02	3925	6.36	3991	6.71	4053	7.04	4117	7.40	4177	7.74	4292	8.41	4403	9.08	4509	9.75	4616	10.44
3240	3100	3936	6.37	4004	6.73	4067	7.08	4130	7.44	4191	7.79	4251	8.14	4367	8.85	4478	9.55	4584	10.24	4687	10.94
3344	3200	4018	6.76	4083	7.12	4144	7.47	4207	7.84	4269	8.22	4330	8.59	4446	9.32	4553	10.04	4656	10.73	4758	11.46
3448	3300	4099	7.15	4161	7.52	4226	7.90	4288	8.27	4345	8.64	4406	9.03	4519	9.76	4627	10.52	4733	11.27	4832	12.00
3553	3400	4180	7.56	4243	7.95	4305	8.33	4363	8.70	4422	9.09	4483	9.50	4597	10.28	4705	11.05	4808	11.81	4907	12.57
3658	3500	4263	8.00	4323	8.38	4386	8.79	4444	9.17	4501	9.56	4559	9.96	4673	10.77	4782	11.56	4885	12.37	4984	13.16
3762	3600	4349	8.47	4408	8.86	4465	9.24	4524	9.65	4581	10.05	4639	10.47	4751	11.30	4856	12.11	4960	12.94	5059	13.76

All Capacities Based on Standard Air (Density .075#/cu.ft. - 70 deg. F. - 29.92" Hg. Bar.)

NOTES: (1) These ratings cover the performance of BOTH Class II and Class III Type NH Fans. Class II Fans can be used for ratings printed in white areas ONLY. Class III Fans can be used for ALL ratings printed in white and grey areas. (2) Ball bearings are standard on all Type NH Fans. (3) Values underlined indicate the most efficient point of operation for each pressure. (4) Performance shown is for installation type B & D - Free or ducted inlet, Ducted outlet. (5) Performance ratings do not include the effects of appurtenances in the airstream. (6) Power rating (BHP) does not include transmission losses.

SIZE 15

SINGLE WIDTH
SINGLE INLET

KCH TYPE NH FANS

NON-OVERLOADING MEDIUM SPEED HIGH EFFICIENCY

CLASSES

II AND III

Outlet Size 11-3/4" x 15-5/8" I.D.

Wheel Diameter 15 in.

Inlet Size 16-1/4" I.D.

Outlet Area 1.29 Sq. Ft. Inside

Tip Speed = RPM x 3.93

Max. BHP = .18



KCH Services certifies that the CI & NH Fans shown herein are licensed to bear the AMCA Seal. The ratings shown are based on tests and procedures performed in accordance with AMCA publication 211 and comply with the requirements of the AMCA Certified Ratings Program.



Volume of Air CFM	Outlet Velocity FPM	1/2" SP		1" SP		1-1/2" SP		2" SP		2-1/2" SP		3" SP		3-1/2" SP		4" SP		4-1/2" SP		5" SP	
		RPM	BHP	RPM	BHP	RPM	BHP	RPM	BHP	RPM	BHP	RPM	BHP	RPM	BHP	RPM	BHP	RPM	BHP	RPM	BHP
903	700	878	0.13	1133	0.25	1351	0.40														
1032	800	929	0.15	1164	0.28	1372	0.44	1559	0.62												
1161	900	985	0.18	1202	0.32	1400	0.48	1579	0.66	1744	0.86	1904	1.08								
1290	1000	1045	0.21	1247	0.36	1433	0.53	1606	0.72	1763	0.92	1913	1.14	2058	1.38						
1419	1100	1108	0.25	1297	0.41	1471	0.58	1636	0.78	1790	0.99	1933	1.21	2069	1.46	2201	1.71	2333	1.98		
1548	1200	1173	0.29	1351	0.46	1515	0.64	1671	0.84	1819	1.06	1959	1.29	2090	1.54	2217	1.80	2339	2.07	2460	2.36
1677	1300	1240	0.34	1409	0.52	1564	0.71	1711	0.92	1853	1.14	1989	1.38	2117	1.63	2239	1.90	2357	2.18	2471	2.47
1806	1400	1309	0.39	1469	0.58	1617	0.79	1756	1.00	1891	1.23	2021	1.48	2147	1.74	2266	2.01	2380	2.29	2491	2.59
1935	1500	1378	0.45	1532	0.66	1672	0.87	1806	1.10	1933	1.33	2058	1.58	2179	1.85	2296	2.12	2408	2.41	2515	2.71
2064	1600	1449	0.52	1596	0.74	1731	0.96	1858	1.20	1980	1.44	2099	1.70	2215	1.97	2328	2.25	2438	2.55	2544	2.85
2193	1700	1520	0.60	1661	0.82	1791	1.06	1913	1.30	2031	1.56	2144	1.82	2255	2.10	2364	2.39	2470	2.69	2574	3.00
2322	1800	1593	0.68	1728	0.92	1853	1.16	1970	1.42	2083	1.68	2193	1.96	2299	2.24	2404	2.54	2506	2.85	2607	3.17
2451	1900	1665	0.78	1796	1.02	1916	1.28	2030	1.54	2138	1.82	2244	2.10	2347	2.40	2447	2.70	2546	3.02	2643	3.34
2580	2000	1739	0.88	1865	1.13	1981	1.40	2090	1.68	2196	1.96	2287	2.26	2397	2.56	2494	2.87	2589	3.20	2682	3.53
2709	2100	1813	0.99	1934	1.26	2046	1.53	2153	1.82	2255	2.12	2353	2.42	2449	2.74	2543	3.06	2635	3.39	2725	3.73
2838	2200	1887	1.11	2004	1.39	2113	1.68	2216	1.98	2315	2.28	2410	2.60	2503	2.92	2594	3.25	2683	3.59	2771	3.94
2967	2300	1962	1.24	2075	1.53	2181	1.83	2281	2.14	2377	2.46	2470	2.78	2560	3.12	2648	3.46	2734	3.81	2819	4.16
3096	2400	2037	1.39	2147	1.68	2249	2.00	2346	2.32	2440	2.65	2530	2.98	2618	3.32	2703	3.68	2787	4.03	2870	4.40
3225	2500	2113	1.54	2219	1.85	2318	2.17	2413	2.50	2504	2.84	2591	3.19	2677	3.54	2760	3.90	2841	4.27	2922	4.65
3354	2600	2188	1.71	2292	2.03	2388	2.36	2480	2.70	2569	3.05	2654	3.41	2737	3.78	2818	4.15	2898	4.52	2976	4.91
3483	2700	2265	1.89	2364	2.22	2459	2.56	2548	2.91	2635	3.28	2718	3.65	2799	4.02	2878	4.40	2956	4.79	3032	5.18
3612	2800	2341	2.06	2438	2.42	2530	2.77	2617	3.14	2701	3.51	2782	3.89	2862	4.28	2939	4.67	3014	5.07	3089	5.47
3741	2900	2417	2.29	2512	2.64	2601	3.00	2686	3.38	2768	3.76	2848	4.15	2925	4.55	3001	4.95	3074	5.36	3147	5.77
3870	3000	2494	2.51	2588	2.87	2673	3.24	2756	3.63	2837	4.02	2914	4.42	2990	4.83	3063	5.25	3136	5.66	3206	6.09

Volume of Air CFM	Outlet Velocity FPM	5-1/2" SP		6" SP		6-1/2" SP		7" SP		7-1/2" SP		8" SP		9" SP		10" SP		11" SP		12" SP	
		RPM	BHP	RPM	BHP	RPM	BHP	RPM	BHP	RPM	BHP	RPM	BHP	RPM	BHP	RPM	BHP	RPM	BHP	RPM	BHP
1806	1400	2598	2.89	2703	3.21	2806	3.54	2910	3.88												
1935	1500	2620	3.03	2721	3.35	2820	3.69	2917	4.03	3014	4.38	3111	4.75								
2064	1600	2646	3.17	2744	3.50	2841	3.84	2935	4.19	3027	4.55	3118	4.92	3300	5.68						
2193	1700	2675	3.33	2771	3.66	2865	4.01	2957	4.36	3047	4.72	3136	5.10	3308	5.87	3479	6.69	3647	7.53		
2322	1800	2705	3.50	2801	3.83	2894	4.18	2983	4.54	3071	4.91	3157	5.29	3325	6.08	3488	6.90	3649	7.76	3809	8.64
2451	1900	2738	3.68	2832	4.02	2923	4.38	3012	4.74	3098	5.12	3183	5.50	3346	6.29	3505	7.12	3690	7.99	3812	8.88
2580	2000	2775	3.87	2865	4.22	2955	4.58	3042	4.95	3128	5.33	3211	5.72	3371	6.52	3527	7.36	3678	8.24	3825	9.14
2709	2100	2814	4.07	2902	4.43	2989	4.80	3074	5.18	3158	5.56	3240	5.96	3399	6.77	3552	7.62	3700	8.50	3844	9.42
2838	2200	2857	4.29	2942	4.66	3026	5.03	3109	5.41	3191	5.81	3272	6.21	3429	7.03	3579	7.89	3724	8.78	3865	9.71
2967	2300	2902	4.52	2985	4.90	3066	5.28	3147	5.67	3227	6.06	3305	6.47	3459	7.31	3609	8.18	3752	9.06	3891	10.02
3096	2400	2951	4.77	3030	5.15	3109	5.54	3187	5.93	3265	6.34	3342	6.75	3492	7.60	3639	8.48	3781	9.40	3918	10.34
3225	2500	3001	5.03	3079	5.42	3155	5.81	3231	6.22	3306	6.63	3381	7.05	3528	7.91	3671	8.80	3811	9.73	3947	10.68
3354	2600	3053	5.30	3128	5.70	3203	6.10	3277	6.51	3350	6.93	3422	7.36	3565	8.23	3706	9.14	3843	10.08	3977	11.04
3483	2700	3106	5.58	3180	5.99	3253	6.40	3325	6.82	3396	7.25	3466	7.68	3605	8.58	3742	9.50	3877	10.44	4009	11.42
3612	2800	3162	5.86	3234	6.30	3305	6.72	3375	7.15	3444	7.59	3513	8.03	3648	8.93	3782	9.87	3913	10.83	4042	11.82
3741	2900	3218	6.19	3289	6.62	3358	7.05	3427	7.49	3494	7.94	3561	8.39	3693	9.31	3823	10.25	3952	11.23	4078	12.23
3870	3000	3276	6.52	3345	6.96	3412	7.40	3480	7.85	3546	8.30	3611	8.76	3740	9.70	3867	10.68	3992	11.65	4116	12.67
3999	3100	3335	6.86	3402	7.31	3469	7.76	3534	8.22	3599	8.68	3663	9.15	3788	10.11	3913	11.08	4035	12.09	4158	13.12
4128	3200	3395	7.22	3461	7.68	3526	8.14	3590	8.61	3653	9.08	3716	9.56	3840	10.53	3961	11.53	4080	12.55	4198	13.59
4257	3300	3456	7.59	3521	8.06	3584	8.53	3647	9.01	3709	9.49	3770	9.98	3891	10.97	4010	11.99	4127	13.02	4242	14.06
4386	3400	3518	7.98	3581	8.46	3644	8.94	3705	9.43	3766	9.92	3826	10.42	3945	11.43	4061	12.47	4176	13.52	4289	14.59
4515	3500	3581	8.38	3643	8.87	3704	9.37	3764	9.86	3824	10.37	3883	10.88	3999	11.91	4113	12.96	4226	14.03	4336	15.12
4644	3600	3644	8.81	3705	9.30	3765	9.81	3824	10.32	3883	10.83	3941	11.35	4054	12.40	4167	13.47	4277	14.56	4386	15.67
4773	3700	3708	9.24	3768	9.75	3827	10.27	3885	10.79	3943	11.31	3999	11.84	4111	12.91	4221	14.01	4329	15.11	4438	16.24

All Capacities Based on Standard Air (Density .075#/cu.ft. - 70 deg. F. - 29.92" Hg. Bar.)

NOTES: (1) These ratings cover the performance of BOTH Class II and Class III Type NH Fans. Class II Fans can be used for ratings printed in white areas ONLY. Class III Fans can be used for ALL ratings printed in white and grey areas. (2) Ball bearings are standard on all Type NH Fans. (3) Values underlined indicate the most efficient point of operation for each pressure. (4) Performance shown is for installation type B & D - Free or ducted Inlet, Ducted outlet. (5) Performance ratings do not include the effects of appurtenances in the airstream. (6) Power rating (BHP) does not include transmission losses.

SIZE 16-1/2

SINGLE WIDTH
SINGLE INLET

KCH TYPE NH FANS

NON-OVERLOADING MEDIUM SPEED HIGH EFFICIENCY

CLASSES

II AND III

Outlet Size 13-1/8" x 17-1/8" I.D.

Wheel Diameter 16-1/2 in.

Inlet Size 17-7/8" I.D.

Outlet Area 1.56 Sq. Ft. Inside

Tip Speed = RPM x 4.32

Max. BHP = .29



KCH Services certifies that the CI & NH Fans shown herein are licensed to bear the AMCA Seal. The ratings shown are based on tests and procedures performed in accordance with AMCA publication 211 and comply with the requirements of the AMCA Certified Ratings Program.

Volume of Air CFM	Outlet Velocity FPM	1/2" SP		1" SP		1-1/2" SP		2" SP		2-1/2" SP		3" SP		3-1/2" SP		4" SP		4-1/2" SP		5" SP	
		RPM	BHP	RPM	BHP	RPM	BHP	RPM	BHP	RPM	BHP	RPM	BHP	RPM	BHP	RPM	BHP	RPM	BHP	RPM	BHP
1092	700	803	0.15	1035	0.30	1233	0.48														
1248	800	850	0.18	1063	0.34	1253	0.53	1423	0.74												
1404	900	902	0.22	1098	0.38	1279	0.58	1441	0.80	1592	1.04	1737	1.30								
1560	1000	957	0.26	1140	0.44	1309	0.64	1466	0.86	1610	1.11	1746	1.38	1877	1.66						
1716	1100	1015	0.30	1186	0.49	1344	0.70	1494	0.94	1634	1.19	1764	1.47	1889	1.76	2009	2.07	2128	2.39		
1872	1200	1075	0.35	1237	0.56	1385	0.78	1527	1.02	1662	1.28	1789	1.56	1908	1.86	2023	2.17	2134	2.50	2244	2.85
2028	1300	1136	0.41	1290	0.63	1430	0.86	1564	1.11	1693	1.38	1816	1.67	1933	1.97	2044	2.29	2151	2.63	2255	2.98
2184	1400	1199	0.48	1345	0.71	1478	0.95	1606	1.22	1728	1.49	1846	1.79	1960	2.10	2069	2.42	2173	2.77	2274	3.12
2340	1500	1263	0.55	1402	0.80	1530	1.06	1651	1.33	1767	1.61	1880	1.92	1990	2.23	2097	2.57	2199	2.91	2297	3.28
2496	1600	1328	0.64	1461	0.89	1584	1.16	1699	1.45	1811	1.75	1918	2.06	2024	2.38	2127	2.72	2226	3.08	2323	3.45
2652	1700	1393	0.73	1521	1.00	1639	1.28	1750	1.58	1857	1.89	1960	2.21	2061	2.54	2160	2.89	2257	3.26	2351	3.63
2808	1800	1460	0.83	1583	1.12	1696	1.41	1803	1.72	1906	2.04	2005	2.37	2102	2.72	2196	3.07	2290	3.45	2381	3.83
2964	1900	1527	0.95	1645	1.24	1754	1.55	1858	1.87	1957	2.21	2052	2.55	2146	2.90	2237	3.27	2326	3.65	2415	4.04
3120	2000	1594	1.07	1708	1.38	1814	1.70	1914	2.04	2009	2.38	2102	2.74	2192	3.10	2280	3.48	2366	3.87	2451	4.27
3276	2100	1662	1.21	1772	1.53	1874	1.87	1971	2.21	2063	2.57	2153	2.94	2240	3.32	2325	3.70	2409	4.10	2491	4.51
3432	2200	1730	1.36	1837	1.69	1936	2.04	2029	2.40	2119	2.77	2206	3.15	2290	3.54	2373	3.94	2454	4.35	2533	4.77
3588	2300	1799	1.52	1902	1.86	1998	2.23	2089	2.60	2176	2.99	2260	3.38	2342	3.78	2422	4.19	2501	4.61	2578	5.04
3744	2400	1868	1.70	1968	2.05	2061	2.43	2149	2.82	2234	3.21	2316	3.62	2395	4.03	2473	4.46	2549	4.89	2624	5.33
3900	2500	1938	1.89	2034	2.26	2124	2.64	2210	3.04	2293	3.46	2372	3.87	2450	4.30	2526	4.74	2600	5.18	2673	5.63
4056	2600	2007	2.09	2101	2.47	2189	2.87	2272	3.29	2352	3.71	2430	4.14	2506	4.58	2579	5.03	2651	5.49	2722	5.95
4212	2700	2077	2.31	2168	2.71	2253	3.12	2335	3.54	2413	3.98	2489	4.43	2562	4.88	2634	5.34	2705	5.81	2774	6.29
4368	2800	2147	2.54	2235	2.95	2319	3.38	2398	3.82	2474	4.27	2548	4.73	2620	5.20	2690	5.67	2759	6.15	2826	6.64
4524	2900	2217	2.80	2303	3.22	2384	3.66	2462	4.11	2536	4.57	2608	5.05	2678	5.53	2747	6.01	2814	6.50	2880	7.01
4680	3000	2288	3.07	2371	3.50	2450	3.95	2526	4.42	2599	4.89	2669	5.38	2738	5.87	2805	6.37	2870	6.88	2935	7.39

Volume of Air CFM	Outlet Velocity FPM	5-1/2" SP		6" SP		6-1/2" SP		7" SP		7-1/2" SP		8" SP		9" SP		10" SP		11" SP		12" SP	
		RPM	BHP	RPM	BHP	RPM	BHP	RPM	BHP	RPM	BHP	RPM	BHP	RPM	BHP	RPM	BHP	RPM	BHP	RPM	BHP
2028	1300	2356	3.34	2457	3.72	2557	4.11														
2184	1400	2371	3.49	2486	3.88	2560	4.27	2654	4.68	2747	5.10										
2340	1500	2391	3.65	2484	4.04	2574	4.45	2662	4.86	2750	5.29	2838	5.73								
2496	1600	2416	3.83	2505	4.23	2593	4.63	2679	5.05	2763	5.49	2846	5.93	3010	6.85						
2652	1700	2442	4.02	2531	4.42	2616	4.84	2699	5.26	2781	5.70	2862	6.15	3019	7.08	3173	8.06	3326	9.08		
2808	1800	2470	4.23	2558	4.63	2642	5.05	2724	5.49	2804	5.93	2882	6.39	3035	7.33	3183	8.32	3329	9.35	3474	10.41
2964	1900	2501	4.44	2586	4.86	2669	5.29	2751	5.73	2829	6.18	2906	6.64	3055	7.60	3199	8.59	3340	9.63	3479	10.71
3120	2000	2535	4.68	2618	5.10	2699	5.54	2778	5.98	2856	6.44	2932	6.91	3078	7.88	3219	8.89	3357	9.94	3491	11.03
3276	2100	2571	4.93	2652	5.36	2730	5.80	2808	6.26	2884	6.72	2959	7.20	3104	8.18	3243	9.20	3377	10.26	3508	11.38
3432	2200	2611	5.20	2688	5.64	2765	6.09	2841	6.55	2915	7.02	2988	7.50	3131	8.50	3268	9.53	3400	10.6	3529	11.72
3588	2300	2654	5.48	2728	5.93	2802	6.39	2875	6.86	2948	7.34	3019	7.83	3159	8.83	3295	9.88	3426	10.97	3552	12.09
3744	2400	2698	5.78	2771	6.24	2842	6.70	2913	7.18	2983	7.67	3053	8.17	3190	9.19	3323	10.25	3453	11.35	3578	12.49
3900	2500	2744	6.09	2815	6.56	2885	7.04	2953	7.52	3021	8.02	3089	8.53	3223	9.57	3353	10.84	3480	11.76	3605	12.90
4056	2600	2792	6.42	2861	6.90	2929	7.39	2996	7.89	3062	8.39	3128	8.90	3258	9.96	3385	11.05	3510	12.18	3632	13.34
4212	2700	2842	6.77	2909	7.26	2975	7.78	3040	8.28	3105	8.78	3169	9.30	3294	10.37	3419	11.49	3542	12.63	3661	13.61
4368	2800	2892	7.13	2958	7.64	3023	8.15	3088	8.66	3149	9.19	3212	9.72	3334	10.81	3465	11.94	3575	13.10	3683	14.29
4524	2900	2945	7.51	3009	8.03	3072	8.55	3134	9.08	3195	9.61	3256	10.16	3376	11.27	3494	12.41	3611	13.59	3726	14.80
4680	3000	2998	7.91	3060	8.44	3122	8.97	3183	9.51	3243	10.06	3303	10.61	3420	11.75	3535	12.91	3648	14.10	3761	15.32
4836	3100	3052	8.33	3113	8.87	3174	9.41	3233	9.97	3282	10.52	3350	11.09	3465	12.24	3577	13.42	3668	14.63	3798	15.87
4992	3200	3108	8.76	3167	9.31	3226	9.87	3285	10.44	3342	11.01	3399	11.59	3511	12.76	3622	13.96	3730	15.19	3837	16.45
5148	3300	3164	9.22	3222	9.78	3280	10.35	3337	10.93	3393	11.51	3449	12.10	3559	13.30	3667	14.62	3773	15.77	3878	17.05
5304	3400	3221	9.69	3278	10.26	3335	10.85	3391	11.44	3448	12.04	3501	12.64	3608	13.86	3714	15.10	3818	16.37	3921	17.67
5460	3500	3279	10.18	3335	10.77	3390	11.37	3445	11.97	3499	12.58	3553	13.19	3658	14.44	3762	15.71	3864	17.00	3965	18.32
5616	3600	3337	10.70	3392	11.30	3446	11.91	3500	12.52	3554	13.14	3606	13.77	3710	15.04	3811	16.34	3912	17.65	4010	18.99

All Capacities Based on Standard Air (Density .075#/cu.ft. - 70 deg. F. - 29.92" Hg. Bar.)

NOTES: (1) These ratings cover the performance of BOTH Class II and Class III Type NH Fans. Class II Fans can be used for ratings printed in white areas ONLY. Class III Fans can be used for ALL ratings printed in white and grey areas. (2) Ball bearings are standard on all Type NH Fans. (3) Values underlined indicate the most efficient point of operation for each pressure. (4) Performance shown is for installation type B & D - Free or ducted inlet, Ducted outlet. (5) Performance ratings do not include the effects of appurtenances in the airstream. (6) Power rating (BHP) does not include transmission losses.

SIZE 18-1/4

SINGLE WIDTH
SINGLE INLET

KCH TYPE NH FANS

NON-OVERLOADING MEDIUM SPEED HIGH EFFICIENCY

CLASSES

II AND III

Outlet Size 14-1/2" x 19" I.D.

Wheel Diameter 18-1/4 in.

Inlet Size 19-3/4" I.D.

Outlet Area 1.91 Sq. Ft. Inside

Tip Speed = RPM x 4.78

Max. BHP = .48



KCH Services certifies that the CI & NH Fans shown herein are licensed to bear the AMCA Seal. The ratings shown are based on tests and procedures performed in accordance with AMCA publication 211 and comply with the requirements of the AMCA Certified Ratings Program.

Volume of Air CFM	Outlet Velocity FPM	1/2" SP		1" SP		1-1/2" SP		2" SP		2-1/2" SP		3" SP		3-1/2" SP		4" SP		4-1/2" SP		5" SP	
		RPM	BHP	RPM	BHP	RPM	BHP	RPM	BHP	RPM	BHP	RPM	BHP	RPM	BHP	RPM	BHP	RPM	BHP	RPM	BHP
1337	700	726	0.19	936	0.37	1115	0.59														
1528	800	769	0.22	962	0.42	1133	0.65	1287	0.91												
1719	900	815	0.26	993	0.47	1156	0.71	1303	0.98	1439	1.27	1571	1.59								
1910	1000	865	0.31	1031	0.53	1184	0.78	1326	1.06	1456	1.36	1578	1.69	1697	2.04						
2101	1100	918	0.37	1073	0.60	1216	0.86	1351	1.15	1478	1.46	1595	1.79	1708	2.15	1816	2.53	1924	2.92		
2292	1200	972	0.43	1118	0.68	1253	0.95	1380	1.25	1503	1.57	1618	1.91	1726	2.28	1829	2.66	1930	3.06	2029	3.49
2483	1300	1028	0.50	1166	0.77	1294	1.06	1414	1.36	1531	1.69	1642	2.04	1748	2.41	1848	2.81	1945	3.22	2039	3.64
2674	1400	1085	0.59	1217	0.87	1338	1.17	1452	1.49	1562	1.83	1670	2.19	1773	2.57	1871	2.97	1965	3.38	2056	3.82
2865	1500	1143	0.68	1269	0.98	1384	1.29	1493	1.63	1598	1.98	1700	2.35	1800	2.74	1896	3.14	1989	3.57	2077	4.01
3056	1600	1201	0.78	1322	1.09	1432	1.43	1537	1.77	1638	2.14	1735	2.52	1830	2.92	1923	3.33	2013	3.77	2101	4.22
3247	1700	1261	0.89	1376	1.22	1483	1.57	1583	1.94	1679	2.31	1773	2.71	1864	3.11	1953	3.54	2041	3.99	2126	4.44
3438	1800	1321	1.02	1432	1.37	1534	1.73	1631	2.11	1724	2.50	1813	2.91	1901	3.33	1986	3.76	2071	4.22	2153	4.69
3629	1900	1381	1.16	1488	1.52	1587	1.90	1680	2.30	1770	2.70	1856	3.12	1941	3.56	2023	4.01	2104	4.47	2184	4.95
3820	2000	1442	1.31	1546	1.69	1641	2.09	1731	2.50	1817	2.92	1901	3.35	1982	3.80	2062	4.26	2140	4.74	2216	5.23
4011	2100	1504	1.48	1603	1.87	1696	2.29	1783	2.71	1866	3.15	1947	3.60	2026	4.06	2103	4.54	2178	5.02	2252	5.52
4202	2200	1566	1.66	1662	2.07	1751	2.50	1836	2.94	1917	3.40	1995	3.86	2071	4.34	2146	4.83	2219	5.33	2291	5.84
4393	2300	1628	1.86	1721	2.28	1807	2.73	1890	3.19	1968	3.66	2044	4.14	2118	4.63	2191	5.13	2262	5.65	2331	6.17
4584	2400	1690	2.08	1780	2.52	1864	2.98	1944	3.45	2021	3.94	2095	4.43	2167	4.94	2237	5.46	2306	5.99	2373	6.52
4775	2500	1753	2.31	1840	2.76	1922	3.24	1999	3.73	2074	4.23	2146	4.75	2216	5.27	2284	5.80	2351	6.35	2417	6.90
4966	2600	1816	2.56	1901	3.03	1980	3.52	2056	4.03	2128	4.55	2198	5.08	2266	5.61	2333	6.16	2398	6.72	2462	7.29
5157	2700	1879	2.83	1961	3.32	2039	3.82	2112	4.34	2183	4.88	2251	5.43	2318	5.98	2383	6.54	2446	7.12	2509	7.70
5348	2800	1942	3.12	2022	3.62	2098	4.14	2169	4.68	2238	5.23	2305	5.80	2370	6.36	2433	6.94	2495	7.53	2556	8.13
5539	2900	2006	3.43	2084	3.95	2157	4.48	2227	5.04	2294	5.60	2359	6.18	2423	6.77	2485	7.36	2545	7.97	2605	8.58
5730	3000	2070	3.76	2145	4.29	2217	4.84	2285	5.41	2351	6.00	2414	6.59	2476	7.20	2537	7.81	2596	8.42	2655	9.05

Volume of Air CFM	Outlet Velocity FPM	5-1/2" SP		6" SP		6-1/2" SP		7" SP		7-1/2" SP		8" SP		9" SP		10" SP		11" SP		12" SP	
		RPM	BHP	RPM	BHP	RPM	BHP	RPM	BHP	RPM	BHP	RPM	BHP	RPM	BHP	RPM	BHP	RPM	BHP	RPM	BHP
2483	1300	2130	4.09	2222	4.56	2312	5.03														
2674	1400	2144	4.27	2230	4.74	2315	5.23	2400	5.73	2483	6.25										
2865	1500	2162	4.47	2246	4.95	2327	5.44	2407	5.95	2486	6.47	2566	7.01								
3056	1600	2184	4.69	2265	5.17	2345	5.67	2422	6.19	2498	6.72	2573	7.26	2721	8.39						
3247	1700	2208	4.92	2288	5.41	2365	5.92	2441	6.44	2515	6.98	2588	7.53	2730	8.67	2869	9.87	3007	11.11		
3438	1800	2234	5.17	2313	5.67	2389	6.19	2463	6.72	2535	7.26	2606	7.82	2744	8.97	2878	10.18	3010	11.44	3141	12.74
3629	1900	2262	5.44	2339	5.95	2414	6.47	2487	7.01	2558	7.56	2627	8.13	2762	9.30	2893	10.52	3020	11.79	3145	13.11
3820	2000	2292	5.73	2367	6.25	2440	6.78	2512	7.33	2583	7.88	2651	8.46	2783	9.64	2911	10.88	3035	12.16	3157	13.50
4011	2100	2325	6.04	2396	6.56	2469	7.11	2539	7.66	2608	8.23	2676	8.81	2807	10.01	2932	11.26	3054	12.56	3172	13.91
4202	2200	2361	6.36	2431	6.90	2500	7.45	2569	8.02	2636	8.59	2702	9.18	2831	10.40	2955	11.67	3075	12.96	3191	14.34
4393	2300	2400	6.71	2467	7.26	2534	7.82	2600	8.39	2666	8.98	2730	9.58	2857	10.82	2980	12.10	3098	13.42	3212	14.80
4584	2400	2440	7.07	2506	7.64	2570	8.21	2634	8.79	2698	9.39	2761	10.00	2885	11.25	3006	12.55	3122	13.90	3235	15.29
4775	2500	2482	7.46	2546	8.03	2609	8.62	2671	9.21	2732	9.82	2793	10.44	2914	11.71	3032	13.03	3147	14.39	3260	15.80
4966	2600	2525	7.87	2588	8.45	2649	9.05	2709	9.66	2769	10.27	2828	10.90	2946	12.20	3061	13.53	3174	14.91	3284	16.34
5157	2700	2570	8.29	2631	8.89	2691	9.50	2750	10.12	2808	10.75	2866	11.39	2979	12.70	3092	14.06	3203	15.46	3311	16.90
5348	2800	2616	8.74	2675	9.35	2734	9.98	2791	10.61	2848	11.25	2905	11.90	3016	13.24	3125	14.62	3233	16.04	3339	17.50
5539	2900	2663	9.20	2721	9.83	2778	10.47	2834	11.12	2890	11.77	2945	12.44	3053	13.80	3160	15.20	3265	16.64	3369	18.12
5730	3000	2712	9.69	2768	10.34	2824	10.99	2879	11.65	2933	12.32	2987	13.00	3093	14.38	3197	15.80	3299	17.26	3401	18.76
5921	3100	2761	10.20	2816	10.86	2870	11.53	2924	12.21	2977	12.89	3030	13.58	3134	14.99	3235	16.44	3335	17.92	3434	19.44
6112	3200	2811	10.73	2865	11.41	2918	12.09	2971	12.78	3023	13.48	3074	14.19	3176	15.63	3275	17.10	3373	18.60	3470	20.14
6303	3300	2862	11.29	2915	11.98	2967	12.68	3018	13.39	3069	14.10	3120	14.82	3219	16.29	3317	17.79	3413	19.31	3507	20.88
6494	3400	2913	11.87	2965	12.57	3016	13.29	3067	14.01	3117	14.74	3168	15.48	3263	16.97	3359	18.50	3453	20.05	3546	21.64
6685	3500	2966	12.47	3017	13.20	3067	13.93	3116	14.66	3165	15.41	3213	16.16	3309	17.69	3403	19.24	3495	20.82	3588	22.43
6876	3600	3018	13.10	3068	13.84	3117	14.59	3166	15.34	3214	16.10	3262	16.87	3355	18.42	3447	20.01	3538	21.82	3627	23.25

All Capacities Based on Standard Air (Density .075#/cu.ft. - 70 deg. F. - 29.92" Hg. Bar.)

NOTES: (1) These ratings cover the performance of BOTH Class II and Class III Type NH Fans. Class II Fans can be used for ratings printed in white areas ONLY. Class III Fans can be used for ALL ratings printed in white and grey areas. (2) Ball bearings are standard on all Type NH Fans. (3) Values underlined indicate the most efficient point of operation for each pressure. (4) Performance shown is for installation type B & D - Free or ducted inlet, Ducted outlet. (5) Performance ratings do not include the effects of appurtenances in the airstream. (6) Power rating (BHP) does not include transmission losses.

SIZE 20

SINGLE WIDTH
SINGLE INLET

KCH TYPE NH FANS

NON-OVERLOADING MEDIUM SPEED HIGH EFFICIENCY

CLASSES

II AND III

Outlet Size 15-7/8" x 20-7/8" I.D.

Wheel Diameter 20 in.

Inlet Size 21-5/8" I.D.

Outlet Area 2.3 Sq. Ft. Inside

Tip Speed = RPM x 5.24

Max. BHP = .76



KCH Services certifies that the CI & NH Fans shown herein are licensed to bear the AMCA Seal. The ratings shown are based on tests and procedures performed in accordance with AMCA publication 211 and comply with the requirements of the AMCA Certified Ratings Program.

Volume of Air CFM	Outlet Velocity FPM	1/2" SP		1" SP		1-1/2" SP		2" SP		2-1/2" SP		3" SP		3-1/2" SP		4" SP		4-1/2" SP		5" SP	
		RPM	BHP	RPM	BHP	RPM	BHP	RPM	BHP	RPM	BHP	RPM	BHP	RPM	BHP	RPM	BHP	RPM	BHP	RPM	BHP
1610	700	663	0.22	854	0.45	1018	0.71														
1840	800	702	0.27	878	0.50	1034	0.78	1174	1.09												
2070	900	745	0.32	907	0.57	1056	0.85	1189	1.18	1313	1.53	1433	1.92								
2300	1000	791	0.38	942	0.64	1081	0.94	1210	1.27	1329	1.64	1441	2.03	1549	2.45						
2530	1100	839	0.44	980	0.73	1110	1.04	1234	1.38	1349	1.76	1456	2.16	1559	2.59	1657	3.04	1755	3.52		
2760	1200	889	0.52	1022	0.82	1144	1.15	1261	1.51	1372	1.89	1477	2.30	1575	2.74	1670	3.20	1761	3.68	1851	4.19
2990	1300	940	0.61	1066	0.93	1182	1.27	1292	1.64	1398	2.04	1499	2.46	1596	2.91	1687	3.38	1775	3.87	1861	4.38
3220	1400	992	0.71	1112	1.05	1222	1.41	1327	1.79	1427	2.20	1524	2.63	1618	3.09	1708	3.57	1794	4.07	1876	4.60
3450	1500	1045	0.82	1159	1.18	1265	1.56	1364	1.96	1460	2.38	1553	2.83	1643	3.29	1731	3.78	1815	4.29	1896	4.83
3680	1600	1098	0.94	1208	1.32	1309	1.72	1404	2.14	1496	2.58	1584	3.03	1671	3.51	1756	4.01	1838	4.54	1918	5.08
3910	1700	1153	1.08	1258	1.48	1355	1.90	1446	2.33	1534	2.79	1619	3.26	1702	3.75	1784	4.27	1863	4.80	1941	5.35
4140	1800	1208	1.23	1309	1.65	1402	2.09	1490	2.54	1575	3.02	1657	3.50	1736	4.01	1814	4.53	1891	5.08	1966	5.64
4370	1900	1263	1.40	1361	1.84	1451	2.30	1536	2.77	1617	3.26	1696	3.76	1773	4.29	1848	4.83	1921	5.38	1994	5.96
4600	2000	1319	1.59	1413	2.04	1500	2.52	1582	3.01	1661	3.52	1737	4.04	1811	4.58	1883	5.14	1954	5.71	2024	6.29
4830	2100	1375	1.79	1466	2.26	1550	2.76	1630	3.27	1706	3.80	1779	4.34	1851	4.90	1921	5.47	1990	6.05	2057	6.65
5060	2200	1432	2.01	1520	2.50	1601	3.02	1678	3.55	1752	4.10	1823	4.66	1893	5.23	1961	5.82	2027	6.42	2093	7.03
5290	2300	1489	2.25	1574	2.76	1652	3.30	1727	3.85	1799	4.41	1868	4.99	1936	5.58	2002	6.19	2066	6.81	2130	7.44
5520	2400	1546	2.51	1628	3.04	1705	3.59	1777	4.17	1847	4.75	1914	5.35	1980	5.96	2044	6.58	2107	7.22	2168	7.86
5750	2500	1603	2.79	1683	3.34	1757	3.91	1828	4.50	1896	5.11	1961	5.73	2025	6.35	2087	7.00	2148	7.65	2208	8.31
5980	2600	1661	3.10	1738	3.66	1810	4.25	1879	4.86	1945	5.49	2009	6.12	2071	6.77	2132	7.43	2191	8.10	2250	8.79
6210	2700	1719	3.43	1794	4.01	1864	4.62	1931	5.24	1995	5.89	2058	6.55	2118	7.21	2177	7.89	2235	8.58	2292	9.28
6440	2800	1777	3.77	1849	4.38	1918	5.00	1983	5.65	2046	6.31	2107	6.99	2166	7.68	2224	8.38	2280	9.08	2336	9.80
6670	2900	1835	4.15	1906	4.77	1972	5.42	2036	6.08	2098	6.76	2157	7.46	2215	8.17	2271	8.88	2326	9.61	2381	10.35
6900	3000	1893	4.55	1962	5.19	2027	5.85	2089	6.54	2149	7.24	2207	7.95	2264	8.68	2319	9.42	2373	10.16	2426	10.92

Volume of Air CFM	Outlet Velocity FPM	5-1/2" SP		6" SP		6-1/2" SP		7" SP		7-1/2" SP		8" SP		9" SP		10" SP		11" SP		12" SP	
		RPM	BHP	RPM	BHP	RPM	BHP	RPM	BHP	RPM	BHP	RPM	BHP	RPM	BHP	RPM	BHP	RPM	BHP	RPM	BHP
2991	1300	1893	4.65																		
3221	1400	1897	4.84	1977	5.38																
3451	1500	1914	5.09	1985	5.61	2061	6.17	2136	6.76												
3682	1600	1941	5.39	2008	5.91	2074	6.45	2142	7.01	2212	7.61	2283	8.24								
3912	1700	1974	5.73	2036	6.25	2099	6.79	2162	7.34	2224	7.92	2289	8.53	2422	9.85						
4142	1800	2011	6.11	2070	6.63	2130	7.17	2189	7.73	2247	8.30	2307	8.90	2427	10.17	2553	11.55				
4372	1900	2053	6.53	2108	7.05	2165	7.59	2221	8.15	2276	8.73	2333	9.33	2445	10.58	2559	11.92	2677	13.37		
4602	2000	2098	7.00	2151	7.52	2203	8.05	2257	8.62	2310	9.20	2363	9.80	2470	11.05	2576	12.38	2685	13.79	2797	15.31
4832	2100	2146	7.49	2197	8.03	2247	8.57	2297	9.13	2347	9.72	2398	10.32	2500	11.57	2601	12.90	2702	14.29	2805	15.76
5062	2200	2195	8.03	2245	8.58	2293	9.14	2341	9.71	2389	10.29	2437	10.88	2534	12.15	2631	13.48	2728	14.87	2824	16.39
5292	2300	2245	8.59	2293	9.16	2341	9.73	2388	10.32	2434	10.91	2480	11.51	2572	12.77	2664	14.11	2757	15.50	2849	16.96
5522	2400	2297	9.19	2344	9.77	2390	10.37	2435	10.96	2481	11.57	2525	12.19	2613	13.45	2701	14.79	2790	16.18	2878	17.64
5753	2500	2349	9.81	2395	10.42	2441	11.04	2485	11.65	2529	12.28	2572	12.90	2657	14.19	2741	15.52	2826	16.92	2912	18.39
5983	2600	2399	10.44	2447	11.10	2492	11.74	2535	12.37	2578	13.01	2621	13.66	2704	14.98	2785	16.32	2865	17.71	2948	19.19
6213	2700	2451	11.10	2498	11.79	2544	12.47	2587	13.13	2629	13.79	2671	14.46	2751	15.80	2831	17.18	2909	18.59	2987	20.05
6443	2800	2503	11.80	2550	12.50	2595	13.22	2639	13.92	2681	14.61	2721	15.29	2800	16.67	2878	18.06	2954	19.51	3029	20.99
6673	2900	2556	12.53	2602	13.25	2647	13.99	2690	14.72	2733	15.46	2773	16.16	2851	17.58	2927	19.02	3001	20.49	3074	21.98
6903	3000	2609	13.28	2654	14.03	2698	14.79	2741	15.55	2784	16.31	2825	17.07	2901	18.53	2976	20.01	3049	21.52	3121	23.04
7133	3100	2663	14.08	2707	14.85	2750	15.63	2793	16.42	2835	17.20	2875	17.98	2953	19.53	3027	21.04	3099	22.58	3169	24.14
7363	3200	2717	14.91	2761	15.71	2804	16.51	2845	17.31	2887	18.12	2927	18.93	3006	20.56	3078	22.12	3149	23.69	3217	25.28
7593	3300	2772	15.79	2815	16.61	2857	17.43	2899	18.26	2939	19.08	2979	19.92	3056	21.59	3130	23.24	3199	24.84	3267	26.48
7823	3400	2828	16.71	2870	17.54	2911	18.38	2952	19.23	2992	20.08	3031	20.93	3107	22.65	3181	24.37	3251	26.08	3318	27.71
8054	3500	2884	17.68	2925	18.52	2966	19.38	3006	20.25	3045	21.12	3084	21.99	3160	23.76	3232	25.63	3303	27.30	3369	29.01
8284	3600	2942	18.69	2981	19.54	3021	20.42	3060	21.31	3099	22.21	3137	23.10	3211	24.90	3284	26.73	3354	28.56	3420	30.33

All Capacities Based on Standard Air (Density .075#cu.ft. - 70 deg. F. - 29.92" Hg. Bar.)

NOTES: (1) These ratings cover the performance of BOTH Class II and Class III Type NH Fans. Class II Fans can be used for ratings printed in white areas ONLY. Class III Fans can be used for ALL ratings printed in white and grey areas. (2) Ball bearings are standard on all Type NH Fans. (3) Values underlined indicate the most efficient point of operation for each pressure. (4) Performance shown is for installation type B & D - Free or ducted Inlet, Ducted outlet. (5) Performance ratings do not include the effects of appurtenances in the airstream. (6) Power rating (BHP) does not include transmission losses.

SIZE 22-1/4

SINGLE WIDTH
SINGLE INLET

KCH TYPE NH FANS

NON-OVERLOADING MEDIUM SPEED HIGH EFFICIENCY

CLASSES

II AND III

Outlet Size 17-5/8" x 23-1/4" I.D.

Wheel Diameter 22-1/4 in.

Inlet Size 24-1/8" I.D.

Outlet Area 2.85 Sq. Ft. Inside

Tip Speed = RPM x 5.83

Max. BHP = 1.29



KCH Services certifies that the CI & NH Fans shown herein are licensed to bear the AMCA Seal. The ratings shown are based on tests and procedures performed in accordance with AMCA publication 211 and comply with the requirements of the AMCA Certified Ratings Program.

Volume of Air CFM	Outlet Velocity FPM	1/2" SP		1" SP		1-1/2" SP		2" SP		2-1/2" SP		3" SP		3-1/2" SP		4" SP		4-1/2" SP		5" SP	
		RPM	BHP	RPM	BHP	RPM	BHP	RPM	BHP	RPM	BHP	RPM	BHP	RPM	BHP	RPM	BHP	RPM	BHP	RPM	BHP
1995	700	596	0.28	768	0.55	915	0.88														
2280	800	632	0.33	789	0.62	930	0.96	1056	1.35												
2565	900	670	0.39	816	0.70	949	1.06	1069	1.46	1181	1.90	1288	2.37								
2850	1000	711	0.47	847	0.80	972	1.17	1088	1.58	1195	2.03	1295	2.51	1392	3.03						
3135	1100	755	0.55	882	0.90	998	1.29	1109	1.71	1213	2.17	1309	2.67	1401	3.20	1490	3.76	1578	4.35		
3420	1200	799	0.65	919	1.02	1029	1.43	1134	1.87	1233	2.34	1328	2.85	1416	3.39	1501	3.96	1583	4.56	1664	5.19
3705	1300	845	0.75	959	1.15	1063	1.58	1161	2.04	1257	2.52	1348	3.05	1435	3.60	1517	4.18	1596	4.79	1673	5.43
3990	1400	892	0.88	1000	1.30	1099	1.75	1193	2.22	1283	2.73	1371	3.28	1455	3.83	1536	4.42	1613	5.04	1687	5.69
4275	1500	940	1.01	1043	1.46	1138	1.93	1227	2.43	1313	2.95	1396	3.50	1478	4.08	1556	4.69	1632	5.32	1704	5.98
4560	1600	988	1.17	1087	1.64	1177	2.13	1263	2.65	1345	3.19	1425	3.76	1503	4.35	1579	4.97	1653	5.62	1724	6.29
4845	1700	1037	1.34	1132	1.83	1219	2.35	1301	2.89	1380	3.46	1456	4.04	1531	4.65	1604	5.29	1675	5.95	1745	6.63
5130	1800	1087	1.53	1178	2.05	1261	2.59	1340	3.15	1416	3.74	1490	4.34	1561	4.97	1631	5.62	1700	6.30	1768	6.99
5415	1900	1137	1.74	1224	2.28	1305	2.85	1381	3.43	1454	4.04	1525	4.67	1594	5.31	1661	5.98	1727	6.67	1793	7.38
5700	2000	1187	1.97	1271	2.53	1349	3.12	1423	3.73	1494	4.36	1562	5.01	1629	5.68	1694	6.37	1757	7.07	1820	7.80
5985	2100	1238	2.22	1319	2.81	1394	3.42	1466	4.06	1534	4.71	1600	5.38	1665	6.07	1728	6.78	1789	7.50	1850	8.24
6270	2200	1288	2.50	1367	3.10	1440	3.74	1509	4.40	1576	5.08	1640	5.77	1702	6.49	1763	7.21	1823	7.96	1882	8.72
6555	2300	1340	2.79	1416	3.43	1487	4.09	1554	4.77	1618	5.47	1680	6.19	1741	6.92	1800	7.67	1858	8.44	1915	9.22
6840	2400	1391	3.12	1465	3.77	1534	4.46	1599	5.17	1661	5.89	1722	6.63	1781	7.39	1838	8.16	1895	8.96	1950	9.75
7125	2500	1443	3.47	1514	4.15	1581	4.85	1644	5.59	1705	6.34	1764	7.10	1822	7.88	1877	8.67	1932	9.48	1986	10.31
7410	2600	1494	3.84	1564	4.55	1629	5.28	1691	6.03	1750	6.81	1807	7.60	1863	8.40	1918	9.21	1971	10.05	2023	10.89
7695	2700	1547	4.25	1614	4.98	1677	5.73	1737	6.51	1795	7.31	1851	8.12	1906	8.95	1959	9.78	2011	10.64	2062	11.51
7980	2800	1599	4.68	1664	5.43	1726	6.21	1784	7.01	1841	7.83	1895	8.67	1948	9.52	2000	10.39	2051	11.26	2101	12.15
8265	2900	1651	5.15	1715	5.92	1775	6.72	1832	7.55	1887	8.39	1940	9.25	1992	10.13	2043	11.02	2093	11.82	2141	12.83
8550	3000	1704	5.65	1766	6.44	1824	7.26	1880	8.11	1934	8.98	1986	9.87	2036	10.77	2086	11.68	2134	12.60	2182	13.54

Volume of Air CFM	Outlet Velocity FPM	5-1/2" SP		6" SP		6-1/2" SP		7" SP		7-1/2" SP		8" SP		9" SP		10" SP		11" SP		12" SP	
		RPM	BHP	RPM	BHP	RPM	BHP	RPM	BHP	RPM	BHP	RPM	BHP	RPM	BHP	RPM	BHP	RPM	BHP	RPM	BHP
3705	1300	1748	6.09	1823	6.78	1896	7.50														
3990	1400	1759	6.37	1830	7.07	1899	7.79	1968	8.54	2037	9.30										
4275	1500	1774	6.67	1843	7.38	1910	8.11	1975	8.86	2040	9.64	2104	10.44								
4560	1600	1793	6.99	1859	7.71	1924	8.45	1988	9.22	2050	10.01	2111	10.81	2232	12.49						
4845	1700	1813	7.34	1878	8.07	1941	8.82	2003	9.60	2064	10.40	2123	11.22	2239	12.92	2354	14.69	2467	16.55		
5130	1800	1834	7.71	1898	8.46	1961	9.22	2021	10.01	2081	10.82	2139	11.65	2252	13.37	2361	15.17	2469	17.04	2577	18.96
5415	1900	1857	8.12	1920	8.86	1981	9.65	2042	10.45	2100	11.27	2156	12.11	2267	13.86	2374	15.67	2478	17.56	2580	19.53
5700	2000	1882	8.55	1943	9.32	2003	10.11	2062	10.93	2120	11.76	2176	12.61	2284	14.37	2389	16.21	2491	18.13	2590	20.11
5985	2100	1910	9.01	1969	9.80	2027	10.60	2085	11.43	2141	12.27	2196	13.14	2304	14.92	2406	16.79	2506	18.72	2603	20.72
6270	2200	1939	9.50	1996	10.30	2053	11.12	2109	11.96	2164	12.82	2218	13.70	2324	15.51	2428	17.39	2523	19.35	2619	21.38
6555	2300	1971	10.02	2026	10.83	2081	11.67	2135	12.53	2189	13.40	2242	14.29	2345	16.13	2446	18.04	2543	20.02	2638	22.06
6840	2400	2005	10.57	2058	11.40	2111	12.25	2163	13.12	2215	14.01	2267	14.92	2368	16.79	2467	18.72	2563	20.72	2655	22.79
7125	2500	2039	11.14	2091	12.00	2143	12.87	2194	13.76	2244	14.66	2294	15.58	2393	17.48	2489	19.44	2584	21.47	2675	23.56
7410	2600	2075	11.75	2126	12.63	2176	13.52	2226	14.42	2275	15.34	2323	16.28	2419	18.20	2513	20.20	2606	22.25	2696	24.57
7695	2700	2112	12.39	2162	13.29	2211	14.20	2259	15.12	2306	16.06	2354	17.01	2447	18.97	2539	20.99	2629	23.07	2718	25.22
7980	2800	2150	13.06	2198	13.98	2246	14.91	2293	15.85	2340	16.81	2386	17.78	2477	19.77	2566	21.82	2655	23.93	2741	26.11
8265	2900	2189	13.76	2236	14.70	2283	15.65	2329	16.61	2374	17.59	2419	18.58	2506	20.61	2596	22.69	2681	24.83	2766	27.04
8550	3000	2229	14.49	2275	15.45	2321	16.43	2366	17.41	2410	18.41	2454	19.42	2541	21.48	2626	23.60	2709	25.77	2783	28.00
8835	3100	2269	15.25	2315	16.24	2359	17.24	2403	18.25	2447	19.27	2490	20.30	2574	22.40	2658	24.55	2739	26.75	2820	29.01
9120	3200	2311	16.05	2355	17.06	2398	18.08	2441	19.11	2484	20.18	2526	21.21	2609	23.35	2691	25.54	2771	27.78	2850	30.07
9405	3300	2353	16.88	2396	17.92	2439	18.96	2481	20.01	2522	21.08	2564	22.15	2645	24.34	2725	26.57	2803	28.85	2881	31.17
9690	3400	2395	17.76	2438	18.81	2480	19.88	2521	20.95	2562	22.04	2602	23.14	2682	25.37	2760	27.64	2837	29.96	2913	32.32
9975	3500	2438	18.67	2480	19.74	2521	20.83	2561	21.93	2601	23.04	2641	24.16	2719	26.43	2796	28.75	2871	31.10	2946	33.51
10260	3600	2482	19.61	2523	20.71	2563	21.82	2603	22.94	2642	24.08	2681	25.22	2757	27.54	2833	29.90	2907	32.29	2980	34.74

All Capacities Based on Standard Air (Density .075#cu.ft. - 70 deg. F. - 29.92" Hg. Bar.)

NOTES: (1) These ratings cover the performance of BOTH Class II and Class III Type NH Fans. Class II Fans can be used for ratings printed in white areas ONLY. Class III Fans can be used for ALL ratings printed in white and grey areas. (2) Ball bearings are standard on all Type NH Fans. (3) Values underlined indicate the most efficient point of operation for each pressure. (4) Performance shown is for installation type B & D - Free or ducted Inlet, Ducted outlet. (5) Performance ratings do not include the effects of appurtenances in the airstream. (6) Power rating (BHP) does not include transmission losses.

SIZE 24-1/2

SINGLE WIDTH
SINGLE INLET

KCH TYPE NH FANS

NON-OVERLOADING MEDIUM SPEED HIGH EFFICIENCY

CLASSES

II AND III

Outlet Size 19-1/2" x 25-1/2" I.D.

Wheel Diameter 24-1/2 in.

Inlet Size 26-1/2" I.D.

Outlet Area 3.453 Sq. Ft. Inside

Tip Speed = RPM x 6.41

Max. BHP = 2.21



KCH Services certifies that the CI & NH Fans shown herein are licensed to bear the AMCA Seal. The ratings shown are based on tests and procedures performed in accordance with AMCA publication 211 and comply with the requirements of the AMCA Certified Ratings Program.



Volume of Air CFM	Outlet Velocity FPM	1/2" SP		1" SP		1-1/2" SP		2" SP		2-1/2" SP		3" SP		3-1/2" SP		4" SP		4-1/2" SP		5" SP	
		RPM	BHP	RPM	BHP	RPM	BHP	RPM	BHP	RPM	BHP	RPM	BHP	RPM	BHP	RPM	BHP	RPM	BHP	RPM	BHP
2417	700	508	0.28	654	0.58																
2782	800	538	0.34	671	0.65	796	1.03														
3108	900	571	0.41	694	0.73	807	1.11	919	1.56												
3453	1000	607	0.49	721	0.82	826	1.22	926	1.66	1027	2.17										
3798	1100	646	0.58	751	0.93	850	1.34	943	1.79	1033	2.29	1125	2.86								
4144	1200	687	0.69	783	1.06	876	1.48	964	1.94	1049	2.45	1131	3.01	1216	3.62						
4489	1300	729	0.81	817	1.20	905	1.63	988	2.11	1069	2.63	1146	3.19	1222	3.80	1300	4.45	1377	5.15		
4834	1400	771	0.94	854	1.35	936	1.81	1015	2.30	1092	2.84	1166	3.41	1237	4.01	1308	4.66	1380	5.36	1452	6.10
5180	1500	814	1.10	892	1.53	969	2.00	1044	2.51	1117	3.06	1188	3.65	1256	4.26	1323	4.91	1389	5.60	1457	6.34
5525	1600	858	1.27	932	1.73	1004	2.22	1075	2.74	1145	3.31	1213	3.90	1279	4.54	1342	5.20	1405	5.89	1467	6.62
5870	1700	902	1.46	973	1.94	1040	2.45	1108	3.00	1175	3.57	1239	4.19	1303	4.83	1364	5.51	1424	6.21	1484	6.94
6215	1800	946	1.67	1014	2.18	1078	2.71	1142	3.27	1206	3.87	1268	4.49	1329	5.15	1388	5.84	1446	6.56	1503	7.30
6561	1900	991	1.90	1056	2.44	1117	2.99	1178	3.57	1239	4.18	1298	4.83	1357	5.50	1414	6.20	1470	6.89	1525	7.69
6906	2000	1035	2.16	1099	2.73	1157	3.30	1215	3.89	1273	4.53	1330	5.18	1386	5.88	1441	6.59	1496	7.34	1549	8.11
7251	2100	1080	2.44	1142	3.04	1196	3.63	1253	4.24	1308	4.90	1363	5.57	1417	6.28	1471	7.01	1523	7.77	1574	8.56
7597	2200	1126	2.74	1186	3.37	1240	3.99	1292	4.63	1345	5.29	1396	5.99	1450	6.71	1501	7.46	1552	8.23	1601	9.03
7942	2300	1171	3.07	1229	3.73	1282	4.38	1333	5.04	1382	5.72	1433	6.43	1483	7.17	1533	7.94	1582	8.73	1630	9.54
8287	2400	1217	3.42	1273	4.12	1325	4.80	1374	5.48	1421	6.18	1469	6.91	1518	7.67	1566	8.45	1613	9.25	1660	10.08
8633	2500	1262	3.81	1318	4.53	1368	5.24	1415	5.95	1461	6.67	1507	7.41	1554	8.19	1600	8.99	1646	9.81	1691	10.66
8978	2600	1308	4.21	1362	4.98	1411	5.72	1457	6.45	1501	7.19	1545	7.95	1590	8.75	1635	9.57	1679	10.41	1723	11.27
9323	2700	1354	4.66	1407	5.45	1455	6.22	1499	6.98	1543	7.75	1585	8.53	1627	9.34	1671	10.18	1714	11.04	1756	11.92
9668	2800	1400	5.13	1451	5.96	1498	6.76	1542	7.55	1584	8.34	1625	9.15	1666	9.97	1707	10.82	1749	11.70	1790	12.60
10014	2900	1446	5.64	1497	6.50	1542	7.33	1585	8.15	1626	8.97	1666	9.80	1705	10.64	1745	11.51	1785	12.40	1825	13.32
10359	3000	1492	6.17	1542	7.07	1586	7.93	1626	8.78	1669	9.63	1707	10.49	1745	11.35	1783	12.22	1822	13.14	1861	14.08

Volume of Air CFM	Outlet Velocity FPM	5-1/2" SP		6" SP		6-1/2" SP		7" SP		7-1/2" SP		8" SP		9" SP		10" SP		11" SP		12" SP	
		RPM	BHP	RPM	BHP	RPM	BHP	RPM	BHP	RPM	BHP	RPM	BHP	RPM	BHP	RPM	BHP	RPM	BHP	RPM	BHP
5180	1500	1824	7.12	1590	7.93																
5525	1600	1530	7.39	1593	8.20	1656	9.05	1717	9.93												
5870	1700	1542	7.71	1600	8.51	1660	9.36	1719	10.24	1778	11.16										
6215	1800	1559	8.08	1614	8.88	1669	9.71	1725	10.59	1782	11.51	1837	12.45								
6561	1900	1579	8.48	1632	9.29	1685	10.12	1737	10.99	1789	11.89	1843	12.84	1949	14.82						
6906	2000	1601	8.91	1653	9.73	1703	10.57	1753	11.45	1803	12.35	1853	13.28	1953	15.25	2054	17.35				
7251	2100	1625	9.37	1675	10.20	1724	11.06	1772	11.94	1820	12.85	1868	13.78	1962	15.73	2058	17.82	2154	20.02	2249	22.32
7597	2200	1651	9.86	1699	10.71	1747	11.58	1794	12.48	1840	13.39	1886	14.33	1977	16.29	2067	18.35	2159	20.55	2250	22.85
7942	2300	1678	10.38	1725	11.25	1771	12.13	1817	13.04	1862	13.97	1906	14.92	1994	16.89	2080	18.95	2167	21.12	2255	23.42
8287	2400	1706	10.94	1752	11.82	1797	12.72	1841	13.64	1885	14.58	1929	15.55	2014	17.54	2097	19.61	2180	21.78	2263	24.05
8633	2500	1736	11.53	1780	12.42	1824	13.34	1867	14.27	1910	15.23	1952	16.21	2035	18.23	2116	20.32	2197	22.50	2276	24.77
8978	2600	1767	12.15	1809	13.06	1852	13.99	1894	14.94	1936	15.91	1977	16.91	2058	18.95	2137	21.07	2215	23.27	2292	25.55
9323	2700	1798	12.82	1840	13.74	1881	14.68	1922	15.65	1963	16.64	2003	17.64	2082	19.72	2160	21.87	2236	24.08	2311	26.38
9668	2800	1831	13.52	1872	14.46	1912	15.42	1952	16.40	1991	17.40	2030	18.42	2108	20.82	2184	22.69	2258	24.94	2331	27.28
10014	2900	1865	14.26	1905	15.21	1944	16.19	1983	17.18	2021	18.20	2059	19.23	2134	21.36	2208	23.57	2281	25.84	2353	28.19
10359	3000	1900	15.03	1938	16.01	1976	17.00	2014	18.01	2052	19.04	2089	20.09	2162	22.25	2234	24.48	2306	26.78	2376	29.16
10704	3100	1935	15.85	1973	16.84	2010	17.85	2047	18.88	2083	19.93	2119	20.99	2191	23.18	2262	25.44	2331	27.77	2400	30.17
11050	3200	1971	16.70	2008	17.72	2044	18.74	2080	19.79	2115	20.85	2151	21.93	2221	24.15	2290	26.44	2358	28.80	2425	31.23
11395	3300	2008	17.60	2044	18.63	2079	19.68	2114	20.74	2149	21.93	2183	22.92	2252	25.17	2319	27.49	2386	29.88	2451	32.34
11740	3400	2046	18.55	2080	19.59	2115	20.66	2149	21.74	2183	22.84	2216	23.96	2283	26.24	2349	28.59	2414	31.01	2479	33.49
12085	3500	2084	19.53	2118	20.60	2151	21.68	2184	22.79	2217	23.90	2250	25.04	2316	27.35	2380	29.73	2444	32.18	2507	34.69
12431	3600	2123	20.57	2155	21.65	2188	22.75	2220	23.87	2253	25.01	2285	26.16	2349	28.51	2412	30.82	2474	33.40	2538	35.95
12776	3700	2164	21.67	2194	22.75	2226	23.67	2257	25.01	2289	26.17	2320	27.34	2382	29.72	2444	32.17	2506	34.68	2566	37.25
13121	3800	2204	22.81	2234	23.91	2264	25.03	2295	26.19	2325	27.37	2356	28.56	2417	30.96	2478	33.46	2537	36.00	2597	38.61

All Capacities Based on Standard Air (Density .075#/cu.ft. - 70 deg. F. - 29.92" Hg. Bar.)

NOTES: (1) These ratings cover the performance of BOTH Class II and Class III Type NH Fans. Class II Fans can be used for ratings printed in white areas ONLY. Class III Fans can be used for ALL ratings printed in white and grey areas. (2) Ball bearings are standard on all Type NH Fans. (3) Values underlined indicate the most efficient point of operation for each pressure. (4) Performance shown is for installation type B & D - Free or ducted Inlet, Ducted outlet. (5) Performance ratings do not include the effects of appurtenances in the airstream. (6) Power rating (BHP) does not include transmission losses.

SIZE 27

SINGLE WIDTH
SINGLE INLET

KCH TYPE NH FANS

NON-OVERLOADING MEDIUM SPEED HIGH EFFICIENCY

CLASSES

II AND III

Outlet Size 21-1/2" x 28-1/8" I.D.

Wheel Diameter 27 in.

Inlet Size 29-1/4" I.D.

Outlet Area 4.199 Sq. Ft. Inside

Tip Speed = RPM x 7.07

Max. BHP = 3.59



KCH Services certifies that the CI & NH Fans shown herein are licensed to bear the AMCA Seal. The ratings shown are based on tests and procedures performed in accordance with AMCA publication 211 and comply with the requirements of the AMCA Certified Ratings Program.

Volume of Air CFM	Outlet Velocity FPM	1/2" SP		1" SP		1-1/2" SP		2" SP		2-1/2" SP		3" SP		3-1/2" SP		4" SP		4-1/2" SP		5" SP	
		RPM	BHP	RPM	BHP	RPM	BHP	RPM	BHP	RPM	BHP	RPM	BHP	RPM	BHP	RPM	BHP	RPM	BHP	RPM	BHP
2939	700	461	0.35	594	0.71																
3359	800	488	0.42	609	0.79	723	1.25														
3779	900	519	0.50	630	0.89	733	1.35	834	1.89												
4199	1000	552	0.59	654	1.00	750	1.48	841	2.02	932	2.64										
4619	1100	587	0.70	681	1.13	771	1.63	856	2.18	938	2.79	1021	3.47								
5039	1200	624	0.83	711	1.29	795	1.80	875	2.36	952	2.98	1027	3.65	1103	4.40						
5459	1300	662	0.98	742	1.46	821	1.99	897	2.57	970	3.20	1040	3.88	1109	4.61	1180	5.41	1250	6.26		
5879	1400	700	1.15	775	1.65	850	2.20	922	2.80	991	3.45	1058	4.14	1123	4.88	1187	5.67	1253	6.51	1318	7.41
6298	1500	740	1.34	810	1.86	880	2.44	948	3.06	1014	3.72	1079	4.43	1140	5.18	1201	5.97	1261	6.81	1322	7.70
6718	1600	779	1.55	846	2.10	912	2.70	978	3.34	1039	4.02	1101	4.75	1161	5.52	1218	6.32	1275	7.16	1332	8.05
7138	1700	819	1.78	883	2.37	945	2.96	1006	3.64	1066	4.35	1125	5.09	1182	5.88	1239	6.70	1293	7.55	1347	8.44
7558	1800	859	2.04	921	2.66	979	3.29	1037	3.98	1095	4.70	1151	5.47	1206	6.27	1260	7.10	1313	7.98	1364	8.88
7978	1900	900	2.32	959	2.98	1014	3.64	1070	4.34	1125	5.09	1179	5.87	1232	6.69	1284	7.55	1335	8.43	1385	9.36
8398	2000	941	2.63	998	3.32	1051	4.02	1103	4.74	1156	5.51	1208	6.31	1259	7.15	1309	8.02	1358	8.93	1406	9.86
8818	2100	982	2.97	1038	3.70	1088	4.42	1138	5.17	1188	5.96	1238	6.78	1287	7.64	1335	8.53	1383	9.45	1429	10.41
9238	2200	1023	3.34	1077	4.11	1126	4.86	1174	5.63	1221	6.44	1269	7.29	1316	8.16	1363	9.07	1409	10.02	1454	10.99
9658	2300	1064	3.74	1117	4.54	1165	5.33	1210	6.13	1255	6.96	1301	7.83	1347	8.73	1392	9.66	1436	10.62	1480	11.61
10078	2400	1105	4.17	1157	5.02	1203	5.84	1248	6.67	1290	7.52	1334	8.41	1378	9.33	1422	10.28	1465	11.26	1507	12.27
10497	2500	1147	4.64	1197	5.52	1242	6.38	1285	7.24	1327	8.12	1368	9.02	1411	9.97	1453	10.94	1494	11.94	1537	12.97
10917	2600	1188	5.14	1237	6.06	1282	6.96	1323	7.86	1364	8.76	1403	9.68	1444	10.65	1485	11.64	1525	12.67	1565	13.71
11337	2700	1230	5.68	1278	6.64	1321	7.58	1362	8.50	1401	9.44	1439	10.39	1478	11.37	1517	12.39	1556	13.43	1595	14.50
11757	2800	1272	6.25	1319	7.26	1361	8.23	1401	9.20	1439	10.16	1476	11.14	1513	12.13	1551	13.17	1588	14.24	1626	15.33
12177	2900	1314	6.87	1359	7.92	1401	8.93	1440	9.93	1477	10.92	1513	11.93	1549	12.95	1585	14.01	1621	15.10	1657	16.21
12597	3000	1355	7.52	1400	8.62	1441	9.66	1479	10.70	1515	11.73	1551	12.77	1585	13.81	1619	14.88	1655	15.99	1690	17.13

Volume of Air CFM	Outlet Velocity FPM	5-1/2" SP		6" SP		6-1/2" SP		7" SP		7-1/2" SP		8" SP		9" SP		10" SP		11" SP		12" SP	
		RPM	BHP	RPM	BHP	RPM	BHP	RPM	BHP	RPM	BHP	RPM	BHP	RPM	BHP	RPM	BHP	RPM	BHP	RPM	BHP
6298	1500	1383	8.85	1443	9.84																
6718	1600	1388	8.98	1446	9.97	1502	11.00	1558	12.07												
7138	1700	1400	9.37	1452	10.35	1506	11.38	1560	12.45	1613	13.56										
7558	1800	1415	9.82	1465	10.79	1515	11.81	1566	12.87	1617	13.98	1667	15.13								
7978	1900	1433	10.31	1481	11.29	1529	12.31	1576	13.36	1624	14.46	1672	15.60	1768	18.01						
8398	2000	1454	10.83	1500	11.83	1546	12.86	1591	13.92	1636	15.01	1681	16.14	1773	18.53	1864	21.08	1954	23.74		
8818	2100	1475	11.39	1521	12.41	1565	13.45	1609	14.52	1652	15.62	1695	16.76	1781	19.12	1868	21.66	1955	24.33	2040	27.12
9238	2200	1498	11.99	1542	13.02	1586	14.08	1628	15.17	1670	16.28	1712	17.43	1794	19.80	1876	22.30	1959	24.97	2042	27.77
9658	2300	1523	12.63	1566	13.66	1608	14.75	1649	15.86	1690	16.99	1730	18.14	1810	20.53	1888	23.04	1966	25.67	2046	28.47
10078	2400	1549	13.31	1590	14.37	1631	15.47	1671	16.59	1711	17.74	1751	18.91	1828	21.32	1904	23.85	1979	26.48	2054	29.23
10497	2500	1576	14.03	1616	15.11	1656	16.22	1695	17.36	1734	18.52	1772	19.71	1847	22.16	1921	24.71	1994	27.35	2066	30.11
10917	2600	1604	14.79	1643	15.89	1681	17.02	1719	18.18	1757	19.36	1795	20.56	1868	23.05	1940	25.62	2011	28.29	2081	31.06
11337	2700	1633	15.60	1671	16.72	1708	17.86	1745	19.04	1782	20.23	1818	21.46	1890	23.98	1961	26.59	2030	29.28	2097	32.07
11757	2800	1663	16.45	1700	17.59	1736	18.76	1772	19.95	1808	21.16	1843	22.40	1913	24.95	1982	27.60	2050	30.33	2116	33.14
12177	2900	1694	17.35	1729	18.51	1765	19.69	1800	20.90	1835	22.14	1869	23.40	1938	25.98	2005	28.66	2071	31.43	2136	34.27
12597	3000	1725	18.29	1760	19.48	1794	20.68	1829	21.91	1863	23.17	1896	24.44	1963	27.06	2029	29.76	2093	32.57	2157	35.46
13017	3100	1757	19.29	1791	20.49	1825	21.72	1858	22.97	1891	24.24	1924	25.54	1989	28.20	2053	30.94	2116	33.77	2179	36.69
13437	3200	1790	20.33	1823	21.56	1856	22.81	1888	24.06	1921	25.37	1953	26.69	2016	29.38	2079	32.16	2141	35.03	2202	37.98
13857	3300	1824	21.43	1856	22.68	1888	23.95	1919	25.24	1951	26.56	1982	27.69	2044	30.62	2105	33.44	2168	36.35	2225	39.33
14277	3400	1858	22.57	1889	23.85	1920	25.14	1951	26.46	1982	27.80	2012	29.15	2073	31.92	2133	34.78	2192	37.72	2250	40.74
14696	3500	1893	23.77	1923	25.07	1953	26.39	1983	27.73	2013	29.09	2043	30.47	2103	33.28	2161	36.17	2219	39.15	2278	42.20
15116	3600	1929	25.04	1957	26.35	1987	27.69	2016	29.05	2046	30.44	2075	31.83	2133	34.69	2190	37.62	2246	40.64	2302	43.73
15536	3700	1965	26.36	1993	27.70	2021	29.06	2050	30.44	2078	31.85	2107	33.27	2163	36.17	2219	39.14	2275	42.19	2330	45.32
15956	3800	2002	27.77	2029	29.11	2058	30.47	2084	31.88	2112	33.31	2140	34.78	2195	37.70	2250	40.72	2304	43.61	2358	46.97

All Capacities Based on Standard Air (Density .075#/cu.ft. - 70 deg. F. - 29.92" Hg. Bar.)

NOTES: (1) These ratings cover the performance of BOTH Class II and Class III Type NH Fans. Class II Fans can be used for ratings printed in white areas ONLY. Class III Fans can be used for ALL ratings printed in white and grey areas. (2) Ball bearings are standard on all Type NH Fans. (3) Values underlined indicate the most efficient point of operation for each pressure. (4) Performance shown is for installation type B & D - Free or ducted Inlet, Ducted outlet. (5) Performance ratings do not include the effects of appurtenances in the airstream. (6) Power rating (BHP) does not include transmission losses.

SIZE 30

SINGLE WIDTH
SINGLE INLET

KCH TYPE NH FANS

NON-OVERLOADING MEDIUM SPEED HIGH EFFICIENCY

CLASSES

II AND III

Outlet Size 23-3/4" x 31-1/4" I.D.

Wheel Diameter 30 in.

Inlet Size 32-1/2" I.D.

Outlet Area 5.154 Sq. Ft. Inside

Tip Speed = RPM x 7.85

Max. BHP = 6.08



KCH Services certifies that the CI & NH Fans shown herein are licensed to bear the AMCA Seal. The ratings shown are based on tests and procedures performed in accordance with AMCA publication 211 and comply with the requirements of the AMCA Certified Ratings Program.

Volume of Air CFM	Outlet Velocity FPM	1/2" SP		1" SP		1-1/2" SP		2" SP		2-1/2" SP		3" SP		3-1/2" SP		4" SP		4-1/2" SP		5" SP	
		RPM	BHP	RPM	BHP	RPM	BHP	RPM	BHP	RPM	BHP	RPM	BHP	RPM	BHP	RPM	BHP	RPM	BHP	RPM	BHP
3608	700	414	0.43	534	0.87																
4123	800	438	0.51	548	0.97	650	1.53														
4639	900	465	0.61	566	1.09	659	1.66	750	2.33												
5154	1000	495	0.72	588	1.23	674	1.82	756	2.48	839	3.24										
5669	1100	526	0.86	612	1.39	693	2.00	769	2.68	843	3.43	919	4.27								
6185	1200	559	1.02	638	1.57	714	2.20	787	2.90	856	3.66	924	4.49	993	5.41						
6700	1300	593	1.20	666	1.78	737	2.43	806	3.15	872	3.93	935	4.77	998	5.67	1062	6.66	1125	7.71		
7216	1400	628	1.40	695	2.01	763	2.69	828	3.43	890	4.23	951	5.09	1010	6.00	1068	6.97	1127	8.02	1186	9.13
7731	1500	663	1.63	726	2.27	790	2.98	851	3.74	911	4.57	969	5.44	1025	6.36	1080	7.34	1134	8.37	1189	9.48
8246	1600	698	1.89	758	2.57	818	3.30	876	4.09	933	4.93	989	5.82	1043	6.77	1095	7.76	1147	8.80	1197	9.89
8762	1700	734	2.17	792	2.89	847	3.64	903	4.46	957	5.33	1010	6.24	1062	7.21	1113	8.22	1162	9.27	1210	10.37
9277	1800	770	2.48	825	3.24	878	4.03	931	4.87	983	5.76	1034	6.70	1083	7.69	1132	8.72	1180	9.79	1226	10.91
9793	1900	806	2.82	860	3.63	909	4.44	960	5.31	1009	6.23	1058	7.19	1106	8.20	1153	9.25	1199	10.35	1244	11.48
10308	2000	842	3.20	894	4.05	942	4.90	989	5.79	1037	6.74	1084	7.73	1130	8.76	1175	9.83	1220	10.95	1263	12.10
10823	2100	879	3.61	929	4.51	976	5.40	1020	6.31	1066	7.29	1111	8.30	1155	9.35	1199	10.45	1241	11.59	1284	12.76
11339	2200	916	4.06	965	5.00	1009	5.93	1052	6.88	1095	7.87	1139	8.92	1181	10.00	1223	11.11	1265	12.27	1306	13.47
11854	2300	952	4.55	1000	5.53	1044	6.51	1085	7.49	1126	8.50	1167	9.57	1208	10.68	1249	11.82	1289	13.01	1329	14.23
12370	2400	989	5.07	1036	6.11	1078	7.12	1118	8.14	1157	9.18	1197	10.28	1237	11.41	1276	12.58	1315	13.79	1353	15.03
12885	2500	1027	5.64	1072	6.72	1113	7.78	1152	8.84	1189	9.91	1227	11.03	1265	12.19	1303	13.39	1341	14.62	1378	15.88
13400	2600	1064	6.24	1108	7.38	1148	8.48	1186	9.58	1222	10.69	1258	11.82	1295	13.02	1332	14.24	1368	15.50	1404	16.79
13916	2700	1101	6.90	1144	8.08	1184	9.23	1220	10.37	1256	11.52	1290	12.68	1325	13.89	1361	15.15	1396	16.43	1431	17.75
14431	2800	1138	7.60	1181	8.83	1219	10.03	1255	11.21	1289	12.39	1323	13.59	1356	14.82	1391	16.10	1425	17.42	1459	18.76
14947	2900	1176	8.35	1217	9.63	1255	10.87	1290	12.10	1324	13.32	1356	14.56	1388	15.81	1421	17.11	1454	18.46	1487	19.83
15462	3000	1213	9.14	1254	10.48	1291	11.77	1325	13.04	1358	14.30	1390	15.58	1421	16.86	1452	18.18	1484	19.55	1516	20.95

Volume of Air CFM	Outlet Velocity FPM	5-1/2" SP		6" SP		6-1/2" SP		7" SP		7-1/2" SP		8" SP		9" SP		10" SP		11" SP		12" SP	
		RPM	BHP	RPM	BHP	RPM	BHP	RPM	BHP	RPM	BHP	RPM	BHP	RPM	BHP	RPM	BHP	RPM	BHP	RPM	BHP
7731	1500	1244	10.65	1299	11.86																
8246	1600	1249	11.05	1301	12.27	1352	13.54														
8762	1700	1258	11.52	1306	12.72	1355	14.00	1404	15.32	1452	16.69										
9277	1800	1272	12.06	1317	13.27	1363	14.52	1408	15.83	1455	17.21	1500	18.62								
9793	1900	1288	12.65	1332	13.87	1375	15.13	1418	16.43	1460	17.78	1504	19.20	1591	22.17						
10308	2000	1306	13.30	1348	14.53	1390	15.79	1431	17.10	1471	18.45	1512	19.84	1595	22.80						
10823	2100	1325	13.98	1366	15.23	1406	16.51	1446	17.63	1485	19.19	1524	20.59	1601	23.51	1681	26.85	1759	29.95	1838	33.39
11339	2200	1346	14.71	1386	15.98	1425	17.29	1463	18.62	1501	20.00	1539	21.40	1613	24.33	1687	27.42	1762	30.72	1837	34.18
11854	2300	1368	15.48	1406	16.77	1444	18.10	1482	19.46	1519	20.86	1555	22.28	1627	25.23	1696	28.32	1769	31.57	1841	35.03
12370	2400	1391	16.31	1428	17.62	1465	18.97	1501	20.35	1537	21.76	1573	23.21	1643	26.18	1711	29.29	1779	32.54	1847	35.95
12885	2500	1415	17.18	1451	18.52	1487	19.89	1522	21.29	1557	22.72	1592	24.19	1660	27.21	1727	30.34	1782	33.61	1857	37.00
13400	2600	1440	18.11	1475	19.47	1510	20.86	1544	22.28	1578	23.74	1612	25.22	1679	28.29	1743	31.46	1807	34.75	1870	38.16
13916	2700	1466	19.09	1500	20.48	1534	21.89	1567	23.33	1600	24.81	1633	26.32	1696	29.42	1762	32.64	1824	35.98	1885	39.39
14431	2800	1492	20.13	1525	21.54	1558	22.97	1591	24.44	1623	25.94	1655	27.46	1719	30.61	1781	33.67	1842	37.23	1902	40.70
14947	2900	1519	21.23	1552	22.66	1584	24.12	1616	25.60	1647	27.13	1678	28.68	1740	31.86	1801	35.16	1861	38.57	1919	42.08
15462	3000	1548	22.38	1579	23.83	1610	25.32	1641	26.83	1672	28.37	1702	29.95	1763	33.18	1822	36.52	1880	39.97	1938	43.52
15977	3100	1576	23.59	1607	25.07	1637	26.58	1668	28.12	1696	29.68	1727	31.28	1786	34.55	1844	37.94	1901	41.43	1957	45.02
16493	3200	1606	24.86	1636	26.37	1666	27.91	1695	29.47	1724	31.06	1753	32.68	1810	36.00	1867	39.43	1922	42.95	1978	46.59
17008	3300	1636	26.19	1665	27.73	1693	29.30	1722	30.89	1751	32.50	1779	34.14	1835	37.51	1890	40.96	1945	44.56	1999	48.23
17524	3400	1666	27.58	1694	29.15	1722	30.75	1750	32.37	1778	34.01	1806	35.68	1861	39.09	1915	42.61	1968	46.23	2021	49.94
18039	3500	1697	29.05	1725	30.64	1752	32.26	1779	33.91	1806	35.58	1833	37.27	1887	40.74	1940	44.30	1992	47.97	2044	51.73
18554	3600	1729	30.58	1755	32.20	1782	33.85	1809	35.53	1835	37.23	1861	38.95	1914	42.46	1965	46.07	2017	49.78	2067	53.59
19070	3700	1761	32.21	1786	33.83	1812	35.50	1838	37.21	1864	38.94	1890	40.69	1941	44.26	1992	47.92	2042	51.67	2091	55.52
19585	3800	1794	33.90	1819	35.55	1843	37.23	1869	38.97	1894	40.72	1919	42.50	1969	46.12	2018	49.83	2068	53.63	2116	57.53

All Capacities Based on Standard Air (Density .075#cu.ft. - 70 deg. F. - 29.92" Hg. Bar.)

NOTES: (1) These ratings cover the performance of BOTH Class II and Class III Type NH Fans. Class II Fans can be used for ratings printed in white areas ONLY. Class III Fans can be used for ALL ratings printed in white and grey areas. (2) Ball bearings are standard on all Type NH Fans. (3) Values underlined indicate the most efficient point of operation for each pressure. (4) Performance shown is for installation type B & D - Free or ducted inlet, ducted outlet. (5) Performance ratings do not include the effects of appurtenances in the airstream. (6) Power rating (BHP) does not include transmission losses.

SIZE 33
SINGLE WIDTH
SINGLE INLET

KCH TYPE NH FANS

NON-OVERLOADING MEDIUM SPEED HIGH EFFICIENCY

CLASSES

II AND III

Outlet Size 26-1/4" x 34-3/8" I.D.

Wheel Diameter 33 in.

Inlet Size 35-5/8" I.D.

Outlet Area 6.266 Sq. Ft. Inside

Tip Speed = RPM x 8.64

Max. BHP = 10.1 9.79



KCH Services certifies that the CI & NH Fans shown herein are licensed to bear the AMCA Seal. The ratings shown are based on tests and procedures performed in accordance with AMCA publication 211 and comply with the requirements of the AMCA Certified Ratings Program.

Volume of Air CFM	Outlet Velocity FPM	1/2" SP		1" SP		1-1/2" SP		2" SP		2-1/2" SP		3" SP		3-1/2" SP		4" SP		4-1/2" SP		5" SP	
		RPM	BHP	RPM	BHP	RPM	BHP	RPM	BHP	RPM	BHP	RPM	BHP	RPM	BHP	RPM	BHP	RPM	BHP	RPM	BHP
4386	700	377	0.52	486	1.06																
5013	800	399	0.62	498	1.18	591	1.86														
5639	900	424	0.74	515	1.33	599	2.01	682	2.82												
6266	1000	451	0.88	535	1.50	614	2.21	688	3.01	762	3.93										
6893	1100	480	1.05	557	1.69	631	2.43	700	3.25	767	4.16	835	5.18								
7519	1200	510	1.24	581	1.92	650	2.68	716	3.53	779	4.45	840	5.45	903	6.57						
8146	1300	541	1.46	607	2.17	672	2.96	734	3.84	794	4.78	851	5.79	908	6.89	965	8.08	1022	9.35		
8772	1400	573	1.71	634	2.46	695	3.28	754	4.18	811	5.15	865	6.18	919	7.28	971	8.46	1025	9.73	1078	11.07
9399	1500	605	1.99	662	2.77	720	3.63	775	4.56	830	5.55	882	6.61	933	7.73	982	8.92	1032	10.16	1081	11.50
10026	1600	637	2.31	692	3.13	745	4.02	799	4.98	850	6.00	900	7.08	949	8.23	997	9.43	1043	10.69	1089	12.01
10652	1700	670	2.65	722	3.53	772	4.45	823	5.44	872	6.49	920	7.60	967	8.77	1013	9.99	1058	11.27	1101	12.60
11279	1800	703	3.04	753	3.96	800	4.91	848	5.93	895	7.02	941	8.16	987	9.35	1031	10.60	1074	11.90	1116	13.25
11905	1900	736	3.46	784	4.44	829	5.43	875	6.48	920	7.59	964	8.76	1007	9.98	1050	11.26	1092	12.58	1133	13.96
12532	2000	769	3.92	816	4.95	859	5.99	902	7.07	945	8.21	988	9.41	1029	10.66	1070	11.96	1111	13.32	1150	14.72
13159	2100	802	4.42	848	5.51	890	6.59	930	7.70	971	8.88	1012	10.11	1052	11.39	1092	12.72	1131	14.10	1169	15.53
13785	2200	836	4.97	880	6.12	921	7.25	959	8.40	999	9.60	1038	10.87	1076	12.18	1115	13.54	1152	14.94	1189	16.39
14412	2300	869	5.57	913	6.77	952	7.95	989	9.14	1026	10.38	1064	11.68	1101	13.02	1138	14.40	1174	15.84	1210	17.32
15038	2400	903	6.21	946	7.47	984	8.70	1020	9.94	1055	11.21	1091	12.54	1127	13.91	1163	15.33	1198	16.79	1232	18.30
15665	2500	937	6.91	979	8.23	1016	9.51	1051	10.80	1085	12.10	1119	13.45	1154	14.87	1188	16.32	1222	17.81	1256	19.34
16292	2600	971	7.65	1012	9.03	1048	10.37	1082	11.71	1115	13.06	1147	14.43	1181	15.88	1214	17.36	1247	18.89	1279	20.45
16918	2700	1005	8.46	1045	9.90	1080	11.29	1113	12.67	1145	14.07	1177	15.48	1208	16.95	1241	18.47	1272	20.03	1304	21.63
17545	2800	1039	9.31	1078	10.81	1113	12.26	1145	13.70	1176	15.14	1207	16.60	1237	18.09	1268	19.64	1299	21.24	1329	22.86
18171	2900	1074	10.23	1111	11.79	1145	13.30	1177	14.79	1208	16.28	1237	17.78	1266	19.31	1296	20.88	1326	22.51	1355	24.17
18798	3000	1108	11.20	1145	12.84	1178	14.40	1209	15.94	1239	17.48	1268	19.03	1296	20.59	1324	22.19	1353	23.85	1382	25.55

Volume of Air CFM	Outlet Velocity FPM	5-1/2" SP		6" SP		6-1/2" SP		7" SP		7-1/2" SP		8" SP		9" SP		10" SP		11" SP		12" SP	
		RPM	BHP	RPM	BHP	RPM	BHP	RPM	BHP	RPM	BHP	RPM	BHP	RPM	BHP	RPM	BHP	RPM	BHP	RPM	BHP
9399	1500	1131	12.91	1181	14.39																
10026	1600	1136	13.40	1183	14.89	1229	16.43	1275	18.02												
10652	1700	1145	13.99	1188	15.44	1232	16.98	1276	18.59	1320	20.25										
11279	1800	1158	14.65	1199	16.11	1239	17.63	1281	19.21	1323	20.88	1364	22.59								
11905	1900	1172	15.38	1212	16.85	1251	18.37	1290	19.95	1328	21.58	1368	23.29	1447	26.89						
12532	2000	1189	16.16	1227	17.65	1265	19.19	1302	20.77	1339	22.41	1375	24.09	1450	27.67	1525	31.47				
13159	2100	1207	17.00	1244	18.52	1280	20.07	1316	21.67	1351	23.32	1387	25.01	1457	28.54	1528	32.33	1599	36.33	1669	40.50
13785	2200	1228	17.89	1262	19.43	1297	21.02	1332	22.64	1386	24.30	1400	26.01	1468	29.55	1534	33.29	1603	37.28	1671	41.46
14412	2300	1246	18.84	1280	20.41	1315	22.02	1349	23.67	1382	25.35	1415	27.08	1480	30.65	1545	34.39	1609	38.32	1674	42.50
15038	2400	1267	19.85	1300	21.44	1334	23.08	1367	24.75	1400	26.46	1432	28.22	1495	31.82	1557	35.59	1619	39.52	1680	43.63
15665	2500	1289	20.92	1322	22.54	1354	24.20	1386	25.90	1418	27.64	1449	29.41	1511	33.07	1571	36.87	1631	40.83	1690	44.94
16292	2600	1312	22.06	1343	23.71	1375	25.39	1406	27.12	1437	28.88	1468	30.68	1528	34.39	1587	38.24	1645	42.22	1702	46.35
16918	2700	1335	23.26	1366	24.94	1397	26.65	1427	28.40	1457	30.19	1487	32.02	1546	35.78	1604	39.68	1660	43.70	1716	47.96
17545	2800	1360	24.53	1390	26.23	1420	27.98	1449	29.75	1479	31.57	1508	33.42	1565	37.23	1621	41.18	1677	45.26	1731	49.46
18171	2900	1385	25.87	1414	27.61	1443	29.37	1472	31.16	1501	33.02	1529	34.91	1585	38.77	1640	42.77	1694	46.90	1747	51.15
18798	3000	1411	27.28	1439	29.05	1467	30.85	1495	32.68	1523	34.56	1551	36.46	1605	40.37	1669	44.42	1712	48.61	1784	52.91
19425	3100	1437	28.76	1465	30.56	1492	32.39	1520	34.26	1547	36.16	1574	38.10	1627	42.07	1679	46.17	1731	50.39	1782	54.75
20051	3200	1464	30.32	1491	32.15	1518	34.02	1544	35.91	1571	37.85	1597	39.81	1649	43.83	1700	47.99	1751	52.27	1801	58.57
20678	3300	1491	31.85	1518	33.82	1544	35.71	1570	37.65	1595	39.61	1621	41.60	1672	45.68	1722	49.89	1771	54.23	1820	58.68
21304	3400	1519	33.86	1545	35.56	1570	37.50	1595	39.46	1621	41.45	1648	43.48	1695	47.62	1744	51.88	1793	56.27	1840	60.78
21931	3500	1548	35.45	1572	37.39	1597	39.36	1622	41.35	1646	43.38	1671	45.44	1719	49.84	1767	53.95	1815	58.40	1861	62.96
22558	3600	1577	37.34	1600	39.29	1625	41.29	1649	43.33	1673	45.39	1697	47.48	1744	51.74	1791	56.12	1837	60.82	1883	65.24
23184	3700	1607	39.33	1629	41.29	1653	43.32	1676	45.39	1699	47.49	1723	49.61	1769	53.94	1815	58.38	1860	62.93	1906	67.81
23811	3800	1637	41.4	1659	43.40	1681	45.44	1704	47.54	1727	49.67	1749	51.83	1795	56.23	1840	60.73	1884	65.34	1926	70.07

All Capacities Based on Standard Air (Density .075#/cu.ft. - 70 deg. F. - 29.92" Hg. Bar.)

NOTES: (1) These ratings cover the performance of BOTH Class II and Class III Type NH Fans. Class II Fans can be used for ratings printed in white areas ONLY. Class III Fans can be used for ALL ratings printed in white and grey areas. (2) Ball bearings are standard on all Type NH Fans. (3) Values underlined indicate the most efficient point of operation for each pressure. (4) Performance shown is for installation type B & D - Free or ducted inlet, Ducted outlet. (5) Performance ratings do not include the effects of appurtenances in the airstream. (6) Power rating (BHP) does not include transmission losses.

SIZE 36-1/2

SINGLE WIDTH
SINGLE INLET

KCH TYPE NH FANS

NON-OVERLOADING MEDIUM SPEED HIGH EFFICIENCY

CLASSES

II AND III

Outlet Size 29" x 38" I.D.

Wheel Diameter 36-1/2 in.

Inlet Size 36-1/2" I.D.

Outlet Area 7.653 Sq. Ft. Inside

Tip Speed = RPM x 9.56

Max. BHP = 16.36



KCH Services certifies that the CI & NH Fans shown herein are licensed to bear the AMCA Seal. The ratings shown are based on tests and procedures performed in accordance with AMCA publication 211 and comply with the requirements of the AMCA Certified Ratings Program.



Volume of Air CFM	Outlet Velocity FPM	1/2" SP		1" SP		1-1/2" SP		2" SP		2-1/2" SP		3" SP		3-1/2" SP		4" SP		4-1/2" SP		5" SP	
		RPM	BHP	RPM	BHP	RPM	BHP	RPM	BHP	RPM	BHP	RPM	BHP	RPM	BHP	RPM	BHP	RPM	BHP	RPM	BHP
5357	700	328	0.57																		
6122	800	346	0.68	439	1.32																
6888	900	367	0.81	450	1.47	532	2.28														
7653	1000	390	0.96	465	1.64	539	2.47														
8418	1100	414	1.13	483	1.84	551	2.69	618	3.65												
9184	1200	438	1.33	504	2.08	566	2.95	628	3.93	688	5.01										
9949	1300	462	1.54	526	2.38	583	3.24	641	4.24	697	5.34	753	6.53								
10714	1400	487	1.79	549	2.66	602	3.56	656	4.59	709	5.71	761	6.92	813	8.22						
11479	1500	513	2.06	572	3.00	623	3.94	673	4.98	723	6.12	772	7.35	821	8.66	870	10.06				
12245	1600	539	2.37	596	3.37	645	4.36	692	5.41	739	6.57	786	7.83	832	9.16	877	10.57	923	12.05		
13010	1700	565	2.71	620	3.77	668	4.82	713	5.90	757	7.08	801	8.35	845	9.70	888	11.13	931	12.63	974	14.19
13775	1800	592	3.09	644	4.19	692	5.32	735	6.44	776	7.63	818	8.92	859	10.29	900	11.74	941	13.26	982	14.84
14541	1900	619	3.50	669	4.66	716	5.86	757	7.03	797	8.24	836	9.54	876	10.94	915	12.40	954	13.94	993	15.55
15306	2000	647	3.96	694	5.16	740	6.43	780	7.66	819	8.91	856	10.22	893	11.64	931	13.12	968	14.68	1005	16.31
16071	2100	674	4.46	720	5.71	764	7.03	804	8.34	841	9.64	877	10.96	912	12.39	948	13.90	984	15.48	1019	17.13
16837	2200	702	5.00	745	6.30	788	7.67	828	9.06	864	10.41	899	11.79	932	13.22	967	14.74	1001	16.34	1035	18.01
17602	2300	730	5.60	772	6.94	813	8.36	852	9.82	888	11.24	921	12.67	954	14.13	986	15.65	1019	17.27	1052	18.95
18367	2400	759	6.24	798	7.63	838	9.10	876	10.61	912	12.12	944	13.59	976	15.10	1007	16.84	1038	18.26	1069	19.97
19132	2500	787	6.94	825	8.37	863	9.89	900	11.46	936	13.04	968	14.57	999	16.13	1029	17.71	1058	19.34	1088	21.05
19898	2600	816	7.68	852	9.17	888	10.73	925	12.35	960	14.00	992	15.61	1022	17.21	1051	18.84	1080	20.50	1108	22.21
20663	2700	844	8.49	879	10.02	914	11.63	949	13.30	983	15.01	1016	16.71	1045	18.36	1074	20.03	1102	21.74	1129	23.48
21428	2800	873	9.35	907	10.93	941	12.58	974	14.30	1008	16.07	1040	17.85	1069	19.57	1097	21.29	1124	23.04	1151	24.82
22194	2900	902	10.28	934	11.90	967	13.60	1000	15.37	1032	17.18	1063	19.02	1093	20.84	1121	22.82	1147	24.41	1174	26.23
22959	3000	931	11.26	962	12.93	994	14.68	1025	16.49	1057	18.36	1088	20.26	1117	22.17	1144	24.01	1171	25.85	1196	27.72

Volume of Air CFM	Outlet Velocity FPM	5-1/2" SP		6" SP		6-1/2" SP		7" SP		7-1/2" SP		8" SP		9" SP		10" SP		11" SP		12" SP	
		RPM	BHP	RPM	BHP	RPM	BHP	RPM	BHP	RPM	BHP	RPM	BHP	RPM	BHP	RPM	BHP	RPM	BHP	RPM	BHP
13010	1700	1017	15.83																		
13775	1800	1023	16.49	1063	18.21																
14541	1900	1031	17.21	1069	18.94	1108	20.74														
15306	2000	1042	17.99	1078	19.74	1115	21.55	1152	23.42	1188	25.33										
16071	2100	1055	18.84	1089	20.60	1124	22.42	1159	24.31	1194	26.25	1229	28.23								
16837	2200	1069	19.74	1102	21.52	1136	23.37	1169	25.27	1202	27.22	1235	29.23	1302	33.40						
17602	2300	1084	20.70	1116	22.51	1149	24.37	1181	26.29	1212	28.26	1244	30.29	1308	34.49	1372	38.89				
18367	2400	1101	21.73	1132	23.56	1163	25.44	1194	27.39	1225	29.38	1255	31.42	1316	35.66	1377	40.09	1439	44.73		
19132	2500	1118	22.84	1148	24.68	1178	26.59	1208	28.55	1238	30.57	1267	32.63	1326	36.90	1385	41.37	1443	46.03		
19898	2600	1137	24.01	1166	25.88	1195	27.81	1224	29.79	1252	31.82	1281	33.91	1338	38.22	1394	42.72	1450	47.42	1507	62.28
20663	2700	1157	25.26	1185	27.16	1213	29.10	1240	31.10	1268	33.16	1296	35.26	1351	39.62	1405	44.16	1458	48.88	1513	53.78
21428	2800	1178	26.63	1204	28.51	1231	30.48	1258	32.50	1285	34.57	1312	36.69	1365	41.10	1418	45.68	1470	50.43	1522	55.37
22194	2900	1199	28.08	1225	29.97	1251	31.83	1277	33.88	1303	36.07	1329	38.22	1380	42.65	1431	47.28	1482	52.07	1533	57.04
22959	3000	1222	29.61	1246	31.53	1271	33.50	1296	35.53	1321	37.65	1346	39.81	1399	44.29	1446	48.96	1495	53.80	1544	58.81
23724	3100	1244	31.20	1268	33.17	1292	35.16	1316	37.20	1340	39.32	1365	41.50	1413	46.02	1462	50.73	1510	55.61	1557	60.66
24490	3200	1267	32.88	1291	34.89	1314	36.92	1338	38.99	1361	41.09	1384	43.28	1431	47.84	1478	52.59	1525	57.51	1571	62.60
25255	3300	1290	34.63	1314	36.68	1337	38.76	1359	40.88	1382	43.00	1404	45.18	1460	49.76	1495	54.54	1541	59.51	1588	64.84
26020	3400	1314	36.46	1337	38.56	1359	40.67	1382	42.82	1404	44.96	1425	47.20	1469	51.76	1514	56.60	1568	61.61	1602	66.77
26785	3500	1338	38.36	1360	40.51	1382	42.67	1404	44.66	1426	47.06	1447	49.31	1489	53.90	1532	58.75	1575	63.79	1618	69.00
27551	3600	1362	40.34	1384	42.54	1408	44.76	1427	46.99	1448	49.25	1469	51.52	1511	56.17	1552	61.00	1594	66.08	1636	71.35
28316	3700	1388	42.39	1408	44.66	1429	46.92	1450	49.21	1471	51.50	1492	53.83	1532	58.55	1572	63.39	1613	68.49	1653	73.78
29081	3800	1410	44.49	1432	46.85	1453	49.17	1474	51.51	1494	53.85	1514	56.21	1554	61.02	1593	65.93	1632	70.99	1672	76.34
29847	3900	1434	46.63	1456	49.12	1477	51.51	1498	53.90	1519	56.29	1538	58.71	1577	63.58	1615	68.56	1653	73.67	1691	79.00
30612	4000	1458	48.86	1480	51.40	1501	53.92	1522	56.37	1541	58.82	1561	61.28	1599	66.24	1637	71.30	1674	76.47	1711	81.76

All Capacities Based on Standard Air (Density .075#/cu.ft. - 70 deg. F. - 29.92" Hg. Bar.)

NOTES: (1) These ratings cover the performance of BOTH Class II and Class III Type NH Fans. Class II Fans can be used for ratings printed in white areas ONLY. Class III Fans can be used for ALL ratings printed in white and grey areas. (2) Ball bearings are standard on all Type NH Fans. (3) Values underlined indicate the most efficient point of operation for each pressure. (4) Performance shown is for installation type B & D - Free or ducted inlet, Ducted outlet. (5) Performance ratings do not include the effects of appurtenances in the airstream. (6) Power rating (BHP) does not include transmission losses.

SIZE 40-1/4

SINGLE WIDTH
SINGLE INLET

KCH TYPE NH FANS

NON-OVERLOADING MEDIUM SPEED HIGH EFFICIENCY

CLASSES

II AND III

Outlet Size 32" x 42" I.D.

Wheel Diameter 40-1/4 in.

Inlet Size 42-1/2" I.D.

Outlet Area 9.333 Sq. Ft. Inside

Tip Speed = RPM x 10.54

Max. BHP = 26.68



KCH Service certifies that the CI & NH Fans shown herein are licensed to bear the AMCA Seal. The ratings shown are based on tests and procedures performed in accordance with AMCA publication 211 and comply with the requirements of the AMCA Certified Ratings Program.

Volume of Air CFM	Outlet Velocity FPM	1/2" SP		1" SP		1-1/2" SP		2" SP		2-1/2" SP		3" SP		3-1/2" SP		4" SP		4-1/2" SP		5" SP	
		RPM	BHP	RPM	BHP	RPM	BHP	RPM	BHP	RPM	BHP	RPM	BHP	RPM	BHP	RPM	BHP	RPM	BHP	RPM	BHP
6533	700	298	0.70																		
7467	800	314	0.83	398	1.61																
8400	900	334	0.98	409	1.79	482	2.77														
9333	1000	354	1.17	422	2.00	489	3.01														
10267	1100	376	1.39	439	2.25	500	3.28	560	4.45												
11200	1200	398	1.62	457	2.54	514	3.59	569	4.79	625	6.11										
12133	1300	420	1.89	477	2.86	529	3.95	581	5.17	632	6.51	683	7.96								
13067	1400	443	2.19	498	3.25	547	4.35	595	5.60	643	6.96	691	8.44	738	10.01						
14000	1500	466	2.52	520	3.67	566	4.81	611	6.07	656	7.46	701	8.96	745	10.56	789	12.25				
14933	1600	490	2.90	542	4.12	586	5.33	628	6.61	671	8.02	713	9.54	755	11.16	796	12.88	837	14.66		
15867	1700	514	3.32	563	4.60	607	5.89	647	7.21	687	8.64	727	10.18	767	11.83	806	13.57	844	15.39	883	17.30
16800	1800	538	3.78	585	5.13	629	6.50	667	7.87	705	9.31	742	10.88	780	12.55	817	14.32	854	16.16	891	18.09
17733	1900	563	4.29	608	5.70	651	7.16	688	8.59	724	10.06	759	11.65	795	13.34	830	15.13	866	17.00	901	18.95
18667	2000	588	4.85	631	6.32	672	7.88	709	9.36	743	10.89	777	12.48	811	14.20	845	16.01	879	17.91	912	19.89
19600	2100	613	5.46	654	6.99	694	8.59	731	10.19	764	11.78	796	13.41	828	15.13	861	16.96	893	18.89	925	20.89
20533	2200	638	6.13	677	7.71	716	9.38	752	11.08	785	12.73	816	14.41	847	16.14	878	18.00	909	19.94	939	21.97
21467	2300	664	6.86	701	8.50	738	10.23	774	12.00	806	13.73	837	15.48	866	17.26	895	19.10	925	21.08	955	23.13
22400	2400	690	7.65	725	9.34	761	11.13	796	12.96	828	14.61	858	16.61	886	18.44	915	20.33	943	22.29	971	24.37
23333	2500	716	8.50	750	10.25	784	12.10	818	14.01	850	15.95	879	17.81	907	19.70	934	21.63	961	23.62	988	25.70
24267	2600	742	9.42	774	11.22	807	13.13	840	15.10	872	17.11	901	19.09	928	21.04	955	23.02	981	25.04	1006	27.12
25200	2700	768	10.40	799	12.26	831	14.23	863	16.27	893	18.34	923	20.43	950	22.44	975	24.48	1001	26.55	1026	28.68
26133	2800	794	11.46	824	13.36	855	15.40	885	17.50	916	19.64	945	21.82	971	23.92	997	26.02	1021	28.15	1046	30.31
27067	2900	820	12.60	848	14.57	879	16.64	909	18.80	938	21.01	966	23.26	993	25.48	1018	27.64	1042	29.83	1066	32.05
28000	3000	847	13.80	875	15.84	903	17.97	932	20.18	960	22.45	988	24.76	1015	27.09	1040	29.35	1063	31.59	1087	33.87

Volume of Air CFM	Outlet Velocity FPM	5-1/2" SP		6" SP		6-1/2" SP		7" SP		7-1/2" SP		8" SP		9" SP		10" SP		11" SP		12" SP	
		RPM	BHP	RPM	BHP	RPM	BHP	RPM	BHP	RPM	BHP	RPM	BHP	RPM	BHP	RPM	BHP	RPM	BHP	RPM	BHP
15867	1700	923	19.29																		
16800	1800	928	20.10	964	22.18																
17733	1900	935	20.98	970	23.09	1005	25.26														
18667	2000	945	21.84	978	24.07	1011	26.26	1045	28.53	1078	30.87										
19600	2100	957	22.97	989	25.11	1020	27.34	1052	29.63	1083	31.99	1115	34.41								
20533	2200	970	24.07	1000	26.24	1031	28.49	1061	30.80	1091	33.18	1121	35.63	1181	40.69						
21467	2300	984	25.26	1013	27.46	1043	29.73	1071	32.06	1100	34.46	1129	36.92	1186	42.04	1244	47.40				
22400	2400	999	26.52	1027	28.74	1056	31.04	1083	33.40	1111	35.82	1139	38.31	1194	43.47	1249	48.86	1306	54.49		
23333	2500	1015	27.87	1043	30.12	1070	32.44	1097	34.82	1124	37.28	1150	39.78	1203	44.99	1256	50.43	1309	56.06	1363	61.97
24267	2600	1033	29.31	1059	31.59	1085	33.93	1111	36.34	1137	38.81	1163	41.35	1214	46.60	1265	52.08	1316	57.79	1367	63.71
25200	2700	1051	30.85	1076	33.15	1101	35.52	1126	37.96	1151	40.46	1176	43.01	1226	48.32	1275	53.84	1324	59.59	1373	65.55
26133	2800	1070	32.52	1094	34.80	1118	37.20	1142	39.66	1166	42.18	1191	44.77	1239	50.12	1287	55.70	1334	61.49	1381	67.49
27067	2900	1089	34.30	1112	36.60	1136	38.98	1159	41.47	1183	44.02	1206	46.63	1253	52.02	1299	57.65	1345	63.49	1391	69.55
28000	3000	1110	36.17	1132	38.51	1154	40.91	1177	43.38	1200	45.95	1222	48.59	1267	54.05	1312	59.71	1357	65.82	1401	71.71
28933	3100	1130	38.13	1152	40.52	1174	42.95	1195	45.43	1217	48.00	1239	50.66	1283	56.16	1327	61.89	1370	67.83	1413	73.97
29867	3200	1151	40.18	1172	42.82	1194	45.10	1215	47.61	1236	50.18	1257	52.84	1299	58.39	1342	64.16	1384	70.16	1426	76.34
30800	3300	1172	42.33	1193	44.82	1214	47.35	1235	49.91	1255	52.51	1275	55.18	1318	60.74	1358	66.56	1399	72.60	1440	78.84
31733	3400	1194	44.56	1214	47.12	1235	49.70	1255	52.31	1275	54.96	1295	57.64	1334	63.18	1374	69.08	1414	75.16	1454	81.45
32667	3500	1215	46.89	1236	49.51	1256	52.14	1276	54.82	1295	57.51	1314	60.24	1353	66.82	1391	71.72	1430	77.85	1469	84.20
33600	3600	1237	49.32	1257	52.00	1277	54.70	1296	57.42	1315	60.18	1334	62.94	1372	68.60	1409	74.48	1447	80.67	1485	87.05
34533	3700	1259	51.83	1279	54.59	1298	57.35	1318	60.14	1336	62.93	1355	65.76	1392	71.52	1428	77.41	1464	83.61	1501	90.06
35467	3800	1281	54.38	1301	57.27	1320	60.10	1339	62.95	1357	65.82	1376	68.69	1412	74.54	1447	80.51	1482	86.67	1518	93.17
36400	3900	1302	57.00	1323	60.05	1342	62.96	1361	65.88	1379	68.80	1397	71.74	1432	77.69	1467	83.75	1501	89.96	1536	96.44
37333	4000	1324	59.74	1345	62.85	1364	65.92	1382	68.90	1400	71.88	1418	74.88	1453	80.95	1487	87.10	1521	93.39	1554	99.84

All Capacities Based on Standard Air (Density .075#/cu.ft. - 70 deg. F. - 29.92" Hg. Bar.)

NOTES: (1) These ratings cover the performance of BOTH Class II and Class III Type NH Fans. Class II Fans can be used for ratings printed in white areas ONLY. Class III Fans can be used for ALL ratings printed in white and grey areas. (2) Ball bearings are standard on all Type NH Fans. (3) Values underlined indicate the most efficient point of operation for each pressure. (4) Performance shown is for installation type B & D - Free or ducted inlet, Ducted outlet. (5) Performance ratings do not include the effects of appurtenances in the airstream. (6) Power rating (BHP) does not include transmission losses.

SIZE 44-1/2

SINGLE WIDTH
SINGLE INLET

KCH TYPE NH FANS

NON-OVERLOADING MEDIUM SPEED HIGH EFFICIENCY

CLASSES

II AND III

Outlet Size 35-3/8" x 46-1/2" I.D.

Wheel Diameter 44-1/2 in.

Inlet Size 47" I.D.

Outlet Area 11.423 Sq. Ft. Inside

Tip Speed = RPM x 11.65

Max. BHP = 44.14



KCH Services certifies that the CI & NH Fans shown herein are licensed to bear the AMCA Seal. The ratings shown are based on tests and procedures performed in accordance with AMCA publication 211 and comply with the requirements of the AMCA Certified Ratings Program.

Volume of Air CFM	Outlet Velocity FPM	1/2" SP		1" SP		1-1/2" SP		2" SP		2-1/2" SP		3" SP		3-1/2" SP		4" SP		4-1/2" SP		5" SP	
		RPM	BHP	RPM	BHP	RPM	BHP	RPM	BHP	RPM	BHP	RPM	BHP	RPM	BHP	RPM	BHP	RPM	BHP	RPM	BHP
7996	700	269	0.86																		
9138	800	284	1.01	360	1.97																
10281	900	302	1.21	370	2.19	436	3.39														
11423	1000	321	1.43	382	2.45	443	3.68														
12565	1100	341	1.70	397	2.75	453	4.02	507	5.45												
13708	1200	360	1.99	414	3.11	465	4.40	515	5.86	565	7.47										
14850	1300	380	2.31	432	3.52	479	4.83	526	6.33	572	7.97	618	9.74								
15992	1400	401	2.68	451	3.99	495	5.33	539	6.85	582	8.52	625	10.32	667	12.25						
17134	1500	422	3.09	471	4.49	512	5.90	553	7.44	594	9.14	634	10.97	674	12.92	714	14.89				
18277	1600	443	3.55	490	5.05	531	6.53	569	8.09	607	9.82	645	11.68	683	13.66	720	15.76	757	17.96		
19419	1700	465	4.06	510	5.64	550	7.22	586	8.82	622	10.57	658	12.46	694	14.48	729	16.60	764	18.83	799	21.16
20561	1800	487	4.63	530	6.28	569	7.96	604	9.64	638	11.40	672	13.32	706	15.37	739	17.52	773	19.78	806	22.14
21704	1900	510	5.26	550	6.98	589	8.77	623	10.52	655	12.33	687	14.26	719	16.33	751	18.52	783	20.81	815	23.19
22846	2000	532	5.94	571	7.74	609	9.82	642	11.47	673	13.34	703	15.28	734	17.39	765	19.60	795	21.92	825	24.34
23988	2100	555	6.70	592	8.56	628	10.53	661	12.48	692	14.42	721	16.42	750	18.53	779	20.77	808	23.12	837	25.57
25131	2200	578	7.52	613	9.45	648	11.49	681	13.57	711	15.59	739	17.65	766	19.77	794	22.03	822	24.42	850	26.89
26273	2300	601	8.41	635	10.41	669	12.53	701	14.71	730	16.83	757	18.95	784	21.14	810	23.39	837	25.81	864	28.31
27415	2400	625	9.38	657	11.45	689	13.64	720	15.90	750	18.14	776	20.35	802	22.59	828	24.89	853	27.30	879	29.83
28557	2500	648	10.42	679	12.56	710	14.83	740	17.17	770	19.54	796	21.82	821	24.13	846	26.49	870	28.92	894	31.46
29700	2600	672	11.55	701	13.76	731	16.09	761	18.51	789	20.97	816	23.36	840	25.77	864	28.19	888	30.67	911	33.21
30842	2700	695	12.76	724	15.04	752	17.44	781	19.93	809	22.48	835	25.03	860	27.50	883	29.99	906	32.52	928	35.12
31984	2800	719	14.06	746	16.40	774	18.88	802	21.44	829	24.07	855	26.73	879	29.31	902	31.88	924	34.48	946	37.13
33127	2900	743	15.45	769	17.86	796	20.41	823	23.04	849	25.75	875	28.49	899	31.22	922	33.87	943	36.54	965	39.25
34269	3000	767	16.93	792	19.42	818	22.03	844	24.74	869	27.52	894	30.34	919	33.18	941	35.95	963	38.70	984	41.48

Volume of Air CFM	Outlet Velocity FPM	5-1/2" SP		6" SP		6-1/2" SP		7" SP		7-1/2" SP		8" SP		9" SP		10" SP		11" SP		12" SP	
		RPM	BHP	RPM	BHP	RPM	BHP	RPM	BHP	RPM	BHP	RPM	BHP	RPM	BHP	RPM	BHP	RPM	BHP	RPM	BHP
19419	1700	834	23.59																		
20561	1800	839	24.59	872	27.14																
21704	1900	846	25.68	878	28.25	909	30.91														
22846	2000	855	26.85	885	29.45	915	32.14	945	34.91	975	37.77										
23988	2100	866	28.11	894	30.74	923	33.45	951	36.25	980	39.13	1008	42.09								
25131	2200	878	29.46	905	32.12	932	34.87	960	37.69	987	40.80	1014	43.59	1068	49.79						
26273	2300	890	30.91	917	33.60	943	36.38	969	39.23	995	42.17	1021	45.18	1073	51.43	1125	57.88				
27415	2400	904	32.47	930	35.18	955	37.99	980	40.88	1005	43.84	1030	46.68	1080	53.18	1130	59.78	1180	66.66		
28557	2500	919	34.13	944	36.88	968	39.71	992	42.62	1017	45.62	1041	48.69	1089	55.06	1136	61.70	1184	68.82	1233	75.82
29700	2600	935	35.89	958	38.68	982	41.54	1005	44.49	1029	47.51	1052	50.61	1098	57.03	1144	63.74	1190	70.70	1236	77.94
30842	2700	951	37.77	974	40.59	996	43.48	1019	46.48	1042	49.52	1064	52.65	1109	59.13	1154	65.88	1198	72.91	1242	80.20
31984	2800	968	39.83	990	42.62	1012	45.55	1034	48.55	1056	51.64	1077	54.80	1121	61.35	1164	68.16	1207	75.25	1249	82.68
33127	2900	986	42.01	1007	44.83	1028	47.73	1049	50.78	1070	53.89	1091	57.08	1134	63.69	1175	70.57	1217	77.70	1258	85.10
34269	3000	1004	44.30	1025	47.17	1045	50.09	1065	53.11	1086	56.26	1106	59.49	1147	66.15	1188	73.09	1228	80.29	1268	87.75
35411	3100	1023	46.70	1043	49.62	1062	52.60	1082	55.63	1102	58.77	1121	62.03	1161	68.75	1200	75.75	1240	83.02	1279	90.53
36554	3200	1042	49.22	1061	52.21	1080	55.24	1099	58.31	1118	61.45	1137	64.76	1176	71.48	1214	78.55	1252	85.97	1290	93.45
37696	3300	1061	51.85	1080	54.90	1099	58.00	1117	61.13	1136	64.31	1154	67.54	1191	74.36	1229	81.49	1268	88.88	1303	96.50
38838	3400	1081	54.59	1099	57.72	1118	60.87	1138	64.07	1154	67.31	1172	70.58	1207	77.38	1244	84.58	1280	92.02	1318	99.72
39981	3500	1100	57.45	1119	60.66	1137	63.88	1154	67.14	1172	70.44	1190	73.77	1224	80.59	1259	87.80	1294	95.31		
41123	3600	1120	60.42	1138	63.70	1156	67.01	1173	70.34	1191	73.69	1208	77.09	1242	84.01	1275	91.19	1310	98.76		
42265	3700	1140	63.51	1158	66.57	1175	70.26	1193	73.56	1210	77.09	1226	80.55	1260	87.59	1292	94.79				
43407	3800	1159	66.62	1178	70.17	1195	73.63	1212	77.11	1229	80.62	1245	84.15	1278	91.29	1310	98.60				
44550	3900	1179	69.84	1198	73.56	1215	77.14	1232	80.69	1248	84.27	1264	87.87	1296	95.15						
45692	4000	1199	73.19	1217	76.98	1235	80.76	1251	84.41	1268	88.06	1284	91.74	1315	99.15						

All Capacities Based on Standard Air (Density .075#/cu.ft. - 70 deg. F. - 29.92" Hg. Bar.)

NOTES: (1) These ratings cover the performance of BOTH Class II and Class III Type NH Fans. Class II Fans can be used for ratings printed in white areas ONLY. Class III Fans can be used for ALL ratings printed in white and grey areas. (2) Ball bearings are standard on all Type NH Fans. (3) Values underlined indicate the most efficient point of operation for each pressure. (4) Performance shown is for installation type B & D - Free or ducted inlet, Ducted outlet. (5) Performance ratings do not include the effects of appurtenances in the airstream. (6) Power rating (BHP) does not include transmission losses.

SIZE 49

SINGLE WIDTH
SINGLE INLET

KCH TYPE NH FANS

NON-OVERLOADING MEDIUM SPEED HIGH EFFICIENCY

CLASSES

II AND III

Outlet Size 39" x 51-1/8" I.D.

Wheel Diameter 49 in.

Inlet Size 51-5/8" I.D.

Outlet Area 13.846 Sq. Ft. Inside

Tip Speed = RPM x 12.83

Max. BHP = 71.34



KCH Services certifies that the CI & NH Fans shown herein are licensed to bear the AMCA Seal. The ratings shown are based on tests and procedures performed in accordance with AMCA publication 211 and comply with the requirements of the AMCA Certified Ratings Program.

Volume of Air CFM	Outlet Velocity FPM	1/2" SP		1" SP		1-1/2" SP		2" SP		2-1/2" SP		3" SP		3-1/2" SP		4" SP		4-1/2" SP		5" SP	
		RPM	BHP	RPM	BHP	RPM	BHP	RPM	BHP	RPM	BHP	RPM	BHP	RPM	BHP	RPM	BHP	RPM	BHP	RPM	BHP
9692	700	245	1.04																		
11077	800	258	1.23	327	2.39																
12461	900	274	1.46	336	2.66	396	4.11														
13846	1000	291	1.74	347	2.97	402	4.46														
15231	1100	309	2.06	361	3.34	411	4.87	460	6.60												
16615	1200	327	2.41	376	3.77	422	5.33	468	7.10	513	9.06										
18000	1300	345	2.80	392	4.27	435	5.86	478	7.67	520	9.66	561	11.81								
19384	1400	364	3.25	410	4.83	449	6.46	489	8.30	529	10.33	567	12.51	606	14.85						
20769	1500	383	3.75	427	5.45	465	7.15	502	9.01	539	11.07	576	13.30	612	15.66	648	18.17				
22154	1600	402	4.30	445	6.12	482	7.91	516	9.80	551	11.90	586	14.16	620	16.56	654	19.10	688	21.78		
23538	1700	422	4.92	463	6.83	499	8.74	532	10.69	565	12.81	597	15.11	630	17.55	682	20.12	694	22.83	726	25.65
24923	1800	442	5.61	481	7.61	517	9.65	548	11.68	579	13.82	610	16.15	641	18.62	672	21.24	702	23.97	732	26.83
26307	1900	463	6.37	500	8.46	535	10.63	565	12.75	595	14.94	624	17.28	653	19.80	682	22.45	711	25.22	740	28.11
27692	2000	483	7.20	518	9.38	553	11.66	583	13.90	611	16.16	639	18.52	666	21.07	694	23.76	722	26.57	749	29.50
29077	2100	504	8.11	538	10.37	570	12.76	600	15.13	628	17.48	654	19.90	681	22.45	707	25.17	734	28.02	760	30.99
30461	2200	525	9.11	557	11.45	589	13.93	619	16.45	645	18.89	671	21.39	696	23.96	721	26.70	747	29.59	772	32.59
31846	2300	546	10.19	577	12.62	607	15.19	636	17.82	663	20.39	688	22.97	712	25.62	736	28.35	760	31.28	784	34.32
33230	2400	567	11.36	596	13.87	626	16.53	654	19.27	681	21.99	705	24.66	729	27.38	752	30.17	775	33.08	798	36.16
34615	2500	588	12.63	616	15.22	645	17.97	672	20.80	699	23.68	723	26.44	746	29.25	768	32.11	790	35.05	812	38.13
36000	2600	610	13.99	637	16.67	664	19.50	691	22.43	717	25.41	740	28.34	763	31.23	785	34.17	806	37.17	827	40.25
37384	2700	631	15.46	657	18.22	683	21.13	709	24.15	734	27.24	759	30.33	780	33.32	802	36.34	823	39.41	843	42.56
38769	2800	653	17.03	678	19.88	703	22.87	728	25.99	753	29.17	776	32.39	798	35.52	819	38.63	839	41.79	859	45.00
40153	2900	674	18.71	698	21.64	723	24.72	747	27.92	771	31.20	794	34.52	816	37.83	837	41.04	857	44.28	876	47.57
41538	3000	696	20.51	719	23.52	742	26.69	766	29.97	789	33.34	812	36.77	834	40.23	855	43.57	874	46.90	893	50.27

Volume of Air CFM	Outlet Velocity FPM	5-1/2" SP		6" SP		6-1/2" SP		7" SP		7-1/2" SP		8" SP		9" SP		10" SP		11" SP		12" SP	
		RPM	BHP	RPM	BHP	RPM	BHP	RPM	BHP	RPM	BHP	RPM	BHP	RPM	BHP	RPM	BHP	RPM	BHP	RPM	BHP
23538	1700	758	28.60																		
24923	1800	762	29.81	792	32.90																
26307	1900	769	31.12	797	34.25	826	37.47														
27692	2000	777	32.64	804	35.69	831	38.95	858	42.32	885	45.78										
29077	2100	786	34.07	812	37.26	838	40.55	864	43.94	890	47.44	916	51.03								
30461	2200	797	35.71	822	38.93	847	42.26	871	45.69	896	49.22	921	52.84	970	60.36						
31846	2300	809	37.47	833	40.73	857	44.10	880	47.56	904	51.11	928	54.77	975	62.35	1022	70.28				
33230	2400	821	39.35	844	42.65	867	46.05	890	49.55	913	53.14	936	56.83	981	64.48	1026	72.47	1072	80.80		
34615	2500	835	41.36	857	44.69	879	48.13	901	51.66	923	55.30	945	59.02	989	66.73	1032	74.80	1075	83.18	1119	91.90
36000	2600	849	43.50	870	46.87	892	50.35	913	53.92	934	57.59	955	61.35	997	69.13	1039	77.26	1081	85.71	1123	94.48
37384	2700	863	45.78	884	49.19	905	52.70	925	56.31	946	60.02	966	63.82	1007	71.68	1048	79.87	1088	88.38	1128	97.22
38769	2800	879	48.28	899	51.65	919	55.20	939	58.85	959	62.59	978	66.42	1018	74.36	1057	82.63	1096	91.21		
40153	2900	895	50.91	914	54.32	933	57.85	953	61.53	972	65.31	991	69.19	1029	77.19	1067	85.53	1105	94.20		
41538	3000	912	53.69	930	57.16	949	60.70	967	64.38	986	68.19	1004	72.10	1041	80.18	1076	88.59	1115	97.34		
42923	3100	929	56.60	947	60.15	965	63.75	982	67.42	1000	71.23	1018	75.17	1054	83.33	1090	91.81				
44307	3200	946	59.65	964	63.27	981	66.94	998	70.67	1015	74.47	1033	78.41	1069	86.64	1103	95.21				
45692	3300	963	62.83	981	66.54	998	70.28	1015	74.08	1031	77.94	1048	81.87	1082	90.13	1116	98.76				
47076	3400	981	66.15	998	69.94	1015	73.77	1031	77.85	1048	81.57	1064	85.66	1098	93.79						
48461	3500	999	69.62	1016	73.50	1032	77.41	1049	81.37	1064	85.37	1080	89.41	1112	97.68						
49846	3600	1017	73.22	1033	77.20	1050	81.21	1066	85.24	1081	89.32	1097	93.43								
51230	3700	1035	76.96	1051	81.04	1067	85.15	1083	89.27	1098	93.42	1114	97.62								
52615	3800	1053	80.74	1069	85.04	1085	89.23	1101	93.45	1116	97.70										
53999	3900	1071	84.64	1087	89.14	1103	93.48	1118	97.79												
55384	4000	1088	88.68	1105	93.29	1121	97.87														

All Capacities Based on Standard Air (Density .075#/cu.ft. - 70 deg. F. - 29.92" Hg. Bar.)

NOTES: (1) These ratings cover the performance of BOTH Class II and Class III Type NH Fans. Class II Fans can be used for ratings printed in white areas ONLY. Class III Fans can be used for ALL ratings printed in white and grey areas. (2) Ball bearings are standard on all Type NH Fans. (3) Values underlined indicate the most efficient point of operation for each pressure. (4) Performance shown is for installation type B & D - Free or ducted inlet, Ducted outlet. (5) Performance ratings do not include the effects of appurtenances in the airstream. (6) Power rating (BHP) does not include transmission losses.

SIZE 54-1/4

SINGLE WIDTH
SINGLE INLET

KCH TYPE NH FANS

NON-OVERLOADING MEDIUM SPEED HIGH EFFICIENCY

CLASSES

II AND III

Outlet Size 43-3/4" x 57-1/8" I.D.

Wheel Diameter 54-1/4 In.

Inlet Size 57-1/4" I.D.

Outlet Area 16.921 Sq. Ft. Inside

Tip Speed = RPM x 14.20

Max. BHP = 118.8



KCH Services certifies that the CI & NH Fans shown herein are licensed to bear the AMCA Seal. The ratings shown are based on tests and procedures performed in accordance with AMCA publication 211 and comply with the requirements of the AMCA Certified Ratings Program.

Volume of Air CFM	Outlet Velocity FPM	1/2" SP		1" SP		1-1/2" SP		2" SP		2-1/2" SP		3" SP		3-1/2" SP		4" SP		4-1/2" SP		5" SP	
		RPM	BHP	RPM	BHP	RPM	BHP	RPM	BHP	RPM	BHP	RPM	BHP	RPM	BHP	RPM	BHP	RPM	BHP	RPM	BHP
11845	700	221	1.27																		
13537	800	233	1.50	295	2.92																
15229	900	247	1.78	303	3.25	358	5.03														
16921	1000	263	2.12	313	3.63	363	5.46														
18613	1100	279	2.51	325	4.08	371	5.95	416	8.08												
20305	1200	295	2.94	339	4.60	381	6.51	422	8.68	463	11.08										
21997	1300	311	3.42	354	5.21	392	7.16	431	9.37	469	11.81	507	14.45								
23689	1400	328	3.96	369	5.89	405	7.88	441	10.14	477	12.62	512	15.30	547	18.16						
25381	1500	345	4.56	385	6.64	419	8.72	453	11.01	487	13.53	520	16.25	552	19.15	585	22.23				
27074	1600	363	5.24	401	7.46	434	9.65	466	11.97	497	14.54	529	17.30	560	20.25	590	23.36	621	26.63		
28766	1700	380	6.00	417	8.33	450	10.66	480	13.05	509	15.65	539	18.46	568	21.45	597	24.60	626	27.91	655	31.38
30458	1800	399	6.83	434	9.28	466	11.77	494	14.25	522	16.86	550	19.72	578	22.76	606	25.96	633	29.31	661	32.81
32150	1900	417	7.75	450	10.31	482	12.96	510	15.55	536	18.23	563	21.10	589	24.18	616	27.42	642	30.83	668	34.37
33842	2000	435	8.76	467	11.43	498	14.22	526	16.95	551	19.72	576	22.60	601	25.73	626	29.02	652	32.46	676	36.06
35534	2100	454	9.87	484	12.64	514	15.55	541	18.45	566	21.32	590	24.28	614	27.41	638	30.75	662	34.23	686	37.87
37226	2200	473	11.08	502	13.95	531	16.98	558	20.05	582	23.04	605	26.09	628	29.25	651	32.60	674	36.14	696	39.82
38918	2300	492	12.39	519	15.36	547	18.50	574	21.73	598	24.86	620	28.02	642	31.25	664	34.61	686	38.19	708	41.91
40610	2400	511	13.82	537	16.89	564	20.14	590	23.49	614	26.81	638	30.07	657	33.40	678	36.81	699	40.39	720	44.16
42302	2500	530	15.36	555	18.53	581	21.88	606	25.35	630	28.86	652	32.25	672	35.68	693	39.18	712	42.77	733	46.55
43995	2600	549	17.02	574	20.29	598	23.75	622	27.33	646	30.98	668	34.55	688	38.08	708	41.68	727	45.35	746	49.12
45687	2700	569	18.80	592	22.17	616	25.74	639	29.43	662	33.20	684	36.97	704	40.83	723	44.33	742	48.08	760	51.93
47379	2800	588	20.71	610	24.19	633	27.85	656	31.66	678	35.55	700	39.49	720	43.30	739	47.11	757	50.97	775	54.90
49071	2900	607	22.76	629	26.33	651	30.10	673	34.01	695	38.02	716	42.08	736	46.12	754	50.05	772	54.01	790	58.02
50763	3000	627	24.94	648	28.62	669	32.49	690	36.51	711	40.63	732	44.62	752	49.04	770	53.12	788	57.20	805	61.32

Volume of Air CFM	Outlet Velocity FPM	5-1/2" SP		6" SP		6-1/2" SP		7" SP		7-1/2" SP		8" SP		9" SP		10" SP		11" SP		12" SP	
		RPM	BHP	RPM	BHP	RPM	BHP	RPM	BHP	RPM	BHP	RPM	BHP	RPM	BHP	RPM	BHP	RPM	BHP	RPM	BHP
28766	1700	684	34.99																		
30458	1800	688	36.46	715	40.24																
32150	1900	694	38.05	720	41.88	746	45.83														
33842	2000	701	39.78	726	43.64	750	47.64	775	51.75	800	56.00										
35534	2100	710	41.64	733	45.55	757	49.58	780	53.73	803	58.02	827	62.42								
37226	2200	719	43.64	742	47.58	764	51.66	787	55.86	809	60.18	831	64.61	876	73.83						
38918	2300	730	45.78	751	49.77	773	53.89	794	58.13	816	62.49	837	66.97	880	76.25	923	85.97				
40610	2400	741	48.06	762	52.10	783	56.27	803	60.56	824	64.96	845	69.47	886	78.84	927	88.64	968	98.86		
42302	2500	753	50.51	773	54.59	793	58.80	813	63.13	833	67.58	853	72.14	892	81.58	932	91.46				
43995	2600	765	53.11	785	57.25	804	61.50	824	65.87	843	70.36	862	74.97	900	84.51	938	94.46				
45687	2700	779	55.88	797	60.06	816	64.36	835	68.79	853	73.32	872	77.97	909	87.60	946	97.64				
47379	2800	793	58.91	811	63.05	829	67.41	847	71.87	865	76.45	883	81.14	919	90.87						
49071	2900	807	62.12	825	66.29	842	70.62	859	75.14	877	79.77	894	84.51	929	94.31						
50763	3000	822	65.49	839	69.74	856	74.08	872	78.59	889	83.26	906	88.05	940	97.94						
52455	3100	838	69.04	854	73.38	870	77.78	886	82.28	902	86.95	919	91.79								
54147	3200	853	72.75	869	77.18	885	81.67	900	86.24	916	90.69	932	95.73								
55839	3300	869	76.62	884	81.15	900	85.74	915	90.39	930	95.10	946	99.91								
57531	3400	885	80.66	900	85.30	915	89.89	930	94.72	945	99.53										
59223	3500	901	84.88	916	89.62	931	94.42	945	99.25												
60916	3600	917	89.26	932	94.12	946	99.03														
62608	3700	933	93.81	948	98.61																
64300	3800	949	98.43																		

All Capacities Based on Standard Air (Density .075#/cu.ft. - 70 deg. F. - 29.92" Hg. Bar.)

NOTES: (1) These ratings cover the performance of BOTH Class II and Class III Type NH Fans. Class II Fans can be used for ratings printed in white areas ONLY. Class III Fans can be used for ALL ratings printed in white and grey areas. (2) Ball bearings are standard on all Type NH Fans. (3) Values underlined indicate the most efficient point of operation for each pressure. (4) Performance shown is for installation type B & D - Free or ducted inlet, Ducted outlet. (5) Performance ratings do not include the effects of appurtenances in the airstream. (6) Power rating (BHP) does not include transmission losses.

SIZE 60

SINGLE WIDTH
SINGLE INLET

KCH TYPE NH FANS

NON-OVERLOADING MEDIUM SPEED HIGH EFFICIENCY

CLASSES

II AND III

Outlet Size 48-3/8" x 63-1/8" I.D.

Wheel Diameter 60 In.

Inlet Size 63-1/4" I.D.

Outlet Area 20.725 Sq. Ft. Inside

Tip Speed = RPM x 15.71

Max. BHP = 196.57

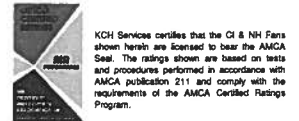

Volume of Air CFM	Outlet Velocity FPM	1/2" SP		1" SP		1-1/2" SP		2" SP		2-1/2" SP		3" SP		3-1/2" SP		4" SP		4-1/2" SP		5" SP	
		RPM	BHP	RPM	BHP	RPM	BHP	RPM	BHP	RPM	BHP	RPM	BHP	RPM	BHP	RPM	BHP	RPM	BHP	RPM	BHP
14508	700	200	1.55																		
16580	800	211	1.83	267	3.58																
18652	900	224	2.18	274	3.97	323	6.16														
20725	1000	238	2.60	283	4.44	328	6.68														
22798	1100	252	3.07	294	4.99	335	7.29	376	9.89												
24870	1200	267	3.60	307	5.64	345	7.98	382	10.63	419	13.57										
26942	1300	282	4.19	320	6.39	355	8.77	390	11.48	424	14.46	458	17.69								
29015	1400	297	4.85	334	7.22	367	9.66	399	12.43	431	15.46	463	18.74	495	22.24						
31088	1500	312	5.60	349	8.14	380	10.69	410	13.48	440	16.57	470	19.90	500	23.45	529	27.21				
33160	1600	328	6.43	363	9.15	393	11.83	421	14.66	450	17.81	478	21.19	506	24.79	534	28.60	562	32.61		
35232	1700	344	7.35	378	10.21	407	13.07	434	15.99	461	19.17	488	22.61	514	26.27	540	30.13	566	34.18	593	38.42
37305	1800	361	8.38	393	11.38	422	14.43	447	17.46	472	20.67	498	24.16	523	27.87	548	31.79	573	35.89	598	40.18
39378	1900	377	9.51	408	12.64	436	15.89	461	19.06	485	22.34	509	25.86	533	29.62	557	33.59	581	37.75	604	42.09
41450	2000	394	10.75	423	14.01	451	17.43	475	20.78	499	24.17	521	27.70	544	31.53	567	35.55	589	39.76	612	44.16
43522	2100	411	12.11	438	15.50	465	19.07	490	22.62	512	26.14	534	29.76	555	33.59	577	37.67	599	41.94	620	46.38
45595	2200	428	13.60	454	17.11	480	20.82	505	24.58	526	28.24	547	31.98	568	35.84	589	39.95	609	44.28	630	48.78
47668	2300	445	15.21	470	18.85	495	22.69	519	26.64	541	30.48	561	34.35	581	38.31	600	42.41	620	46.79	640	51.35
49740	2400	462	16.96	486	20.72	510	24.70	534	28.80	555	32.87	575	36.86	594	40.94	613	45.12	632	49.49	651	54.10
51812	2500	480	18.85	503	22.73	526	26.84	548	31.09	570	35.39	590	39.53	608	43.73	627	48.02	645	52.42	663	57.05
53885	2600	497	20.88	519	24.89	541	29.13	563	33.52	585	37.98	604	42.36	622	46.69	640	51.09	658	55.59	675	60.20
55958	2700	515	23.07	536	27.21	557	31.57	578	36.09	599	40.71	619	45.33	637	49.81	654	54.34	671	58.94	688	63.65
58030	2800	532	25.42	553	29.68	573	34.17	594	38.83	614	43.59	633	48.41	651	53.09	668	57.76	685	62.48	701	67.29
60102	2900	550	27.93	569	32.32	589	36.93	609	41.72	629	46.63	648	51.60	666	56.55	683	61.35	699	66.21	715	71.13
62175	3000	568	30.62	586	35.12	606	39.86	625	44.78	644	49.83	663	54.96	681	60.13	697	65.13	713	70.12	729	75.16

Volume of Air CFM	Outlet Velocity FPM	5-1/2" SP		6" SP		6-1/2" SP		7" SP		7-1/2" SP		8" SP		9" SP		10" SP		11" SP		12" SP	
		RPM	BHP	RPM	BHP	RPM	BHP	RPM	BHP	RPM	BHP	RPM	BHP	RPM	BHP	RPM	BHP	RPM	BHP	RPM	BHP
35232	1700	619	42.83																		
37305	1800	622	44.64	647	49.27																
39378	1900	627	46.60	651	51.28	674	56.12														
41450	2000	634	48.72	656	53.44	678	58.33	701	63.37	723	68.56										
43522	2100	642	51.00	663	55.78	684	60.71	705	65.80	727	71.03	748	76.42								
45595	2200	650	53.45	671	58.28	691	63.26	711	68.40	732	73.69	752	79.11	792	90.38						
47668	2300	660	56.07	680	60.96	699	66.00	719	71.19	738	76.53	757	82.00	796	93.36						
49740	2400	670	58.88	689	63.82	708	68.92	727	74.17	745	79.55	764	85.07	801	96.53						
51812	2500	681	61.88	699	66.88	717	72.03	736	77.33	754	82.78	771	88.35	807	99.91						
53885	2600	692	65.08	710	70.14	728	75.34	745	80.70	762	86.19	780	91.83								
55958	2700	704	68.48	721	73.59	738	78.86	755	84.27	772	89.82	789	95.50								
58030	2800	717	72.20	733	77.27	750	82.59	766	88.05	782	93.66	799	99.40								
60102	2900	730	76.14	746	81.25	762	86.54	777	92.06	793	97.73										
62175	3000	744	80.28	759	85.49	774	90.79	789	96.30												
64248	3100	758	84.62	773	89.93	787	95.34														
66320	3200	772	89.17	786	94.60																
68392	3300	786	93.93	800	99.48																
70465	3400	800	98.90																		

All Capacities Based on Standard Air (Density .075#/cu.ft. - 70 deg. F. - 29.92" Hg. Bar.)

NOTES: (1) These ratings cover the performance of BOTH Class II and Class III Type NH Fans. Class II Fans can be used for ratings printed in white areas ONLY. Class III Fans can be used for ALL ratings printed in white and grey areas. (2) Ball bearings are standard on all Type NH Fans. (3) Values underlined indicate the most efficient point of operation for each pressure. (4) Performance shown is for installation type B & D - Free or ducted inlet, Ducted outlet. (5) Performance ratings do not include the effects of appurtenances in the airstream. (6) Power rating (BHP) does not include transmission losses.



KCH Services certifies that the CI and NH Fans shown herein are licensed to bear the AMCA Seal. The ratings shown are based on tests and procedures performed in accordance with AMCA publication 211 and comply with the requirements of the AMCA Certified Ratings Program.

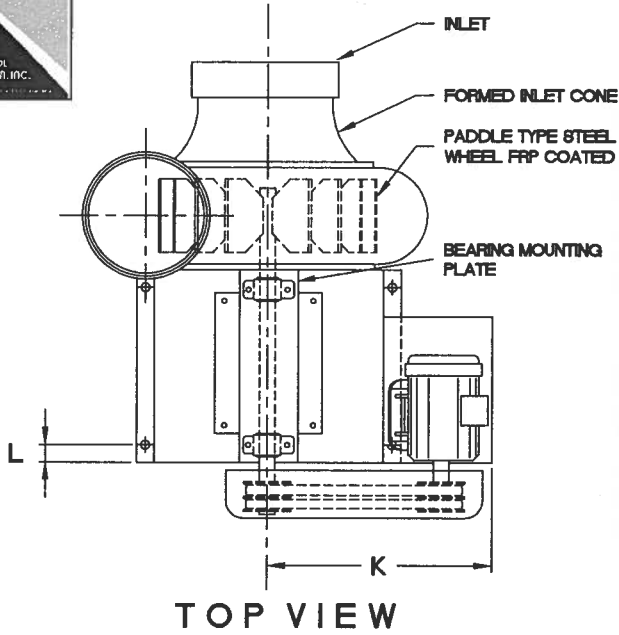

CENTRIFUGAL CI BLOWER NO.	
KCH Forest City, N.C. - Howe, IN.	
USER:	
PURCHASER:	
DATE:	JOB NUMBER:
<input type="checkbox"/> PROVIDING PUSH AIR	<input type="checkbox"/> PROVIDING EXHAUST
C.F.M.:	VENTING:
STATIC PRESSURE:	MAT. TYPE:
CLASS:	ARRANGMENT:
ROTATION:	DISCHARGE:
BHP:	FAN RPM:
MOTOR H.P.:	MOTOR RPM:
VOLTAGE:	
DRIVR SHV:	DRIVN SHV:
DRIVR BUSHNG:	DRIVN BUSHNG:
BELTS:	BEARINGS:
NOTE:	

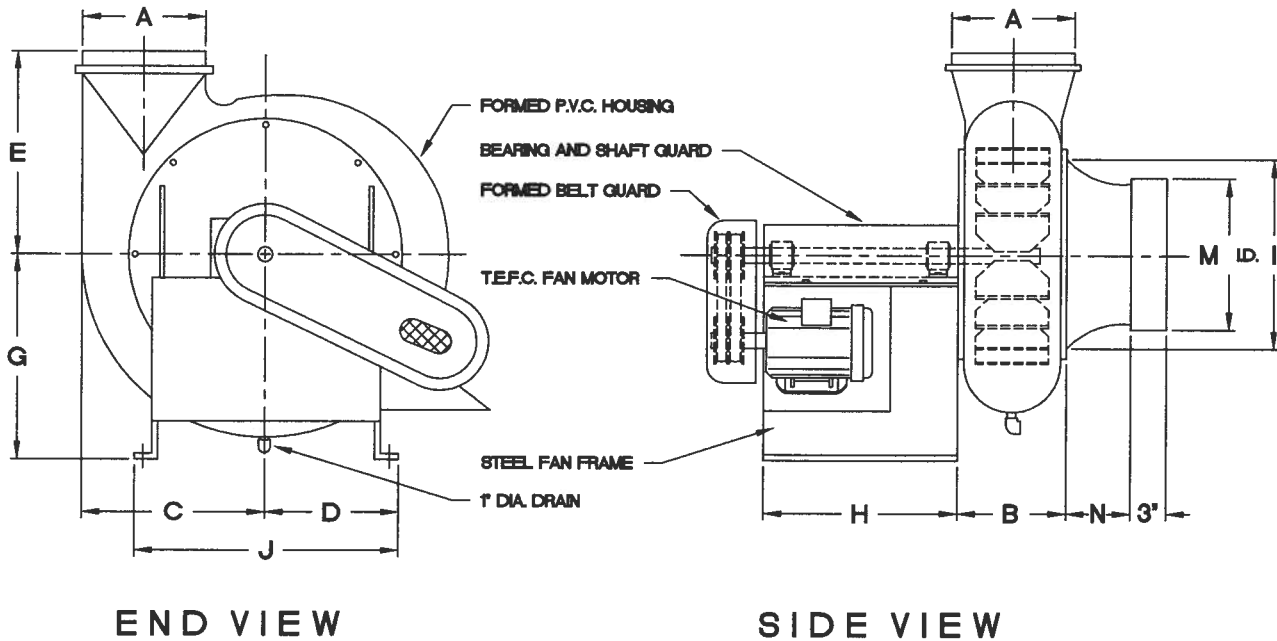

SCHEDULE ALL DIMENSIONS IN INCHES

FAN NO.	A _{OD}	B _{OD}	C	D	E	G	H	I	J	K	L	M _{ID}	N	WEIGHT (LESS MOTOR)
CI- 6	6.375	5.00	9.750	8.938	10.500	11.0	14.5	11.0	15.0	14.500	1.00	6.625	4.00	13 0
CI- 8	8.250	7.00	13.125	10.938	14.250	14.0	16.0	14.5	17.0	16.250	1.25	8.625	5.00	17 0
CI- 10	10.375	8.25	16.000	13.625	17.250	17.0	17.0	18.0	20.5	18.750	2.00	10.750	6.00	21 0

1. EPOXY COATED STEEL FAN FRAME
2. PVC HOUSING
3. PVC DRAIN COUPLING
4. STEEL PADDLE WHEEL
5. PVC INLET CONE
6. PVC INLET COLLAR
7. PVC OUTLET SLEEVE

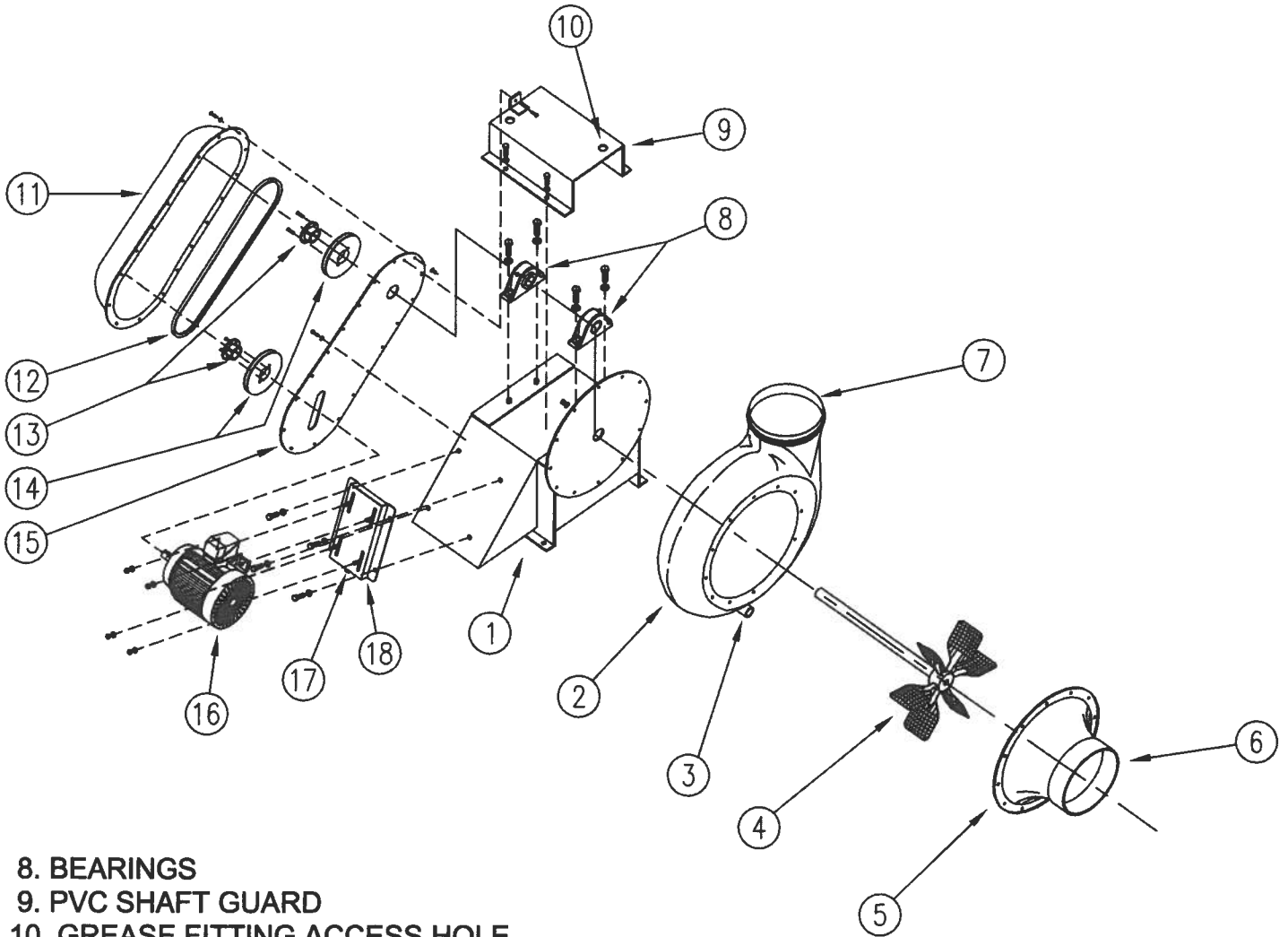

8. BEARINGS
9. PVC SHAFT GUARD
10. GREASE FITTING ACCESS HOLE
11. PVC BELT GUARD
12. BELT
13. DRIVE BUSHINGS
14. DRIVES
15. PVC BELT GUARD BACK PLATE
16. MOTOR
17. MOTOR BASE ADJUSTING BOLT
18. ADJUSTABLE MOTOR BASE

CI - SERIES BLOWER PARTS LIST



KCH Services certifies that the CI and NH Fans shown herein are licensed to bear the AMCA Seal. The ratings shown are based on tests and procedures performed in accordance with AMCA publication 211 and comply with the requirements of the AMCA Certified Ratings Program.

CENTRIFUGAL NH FAN NO.



FOREST CITY, NC - HOWE, IN

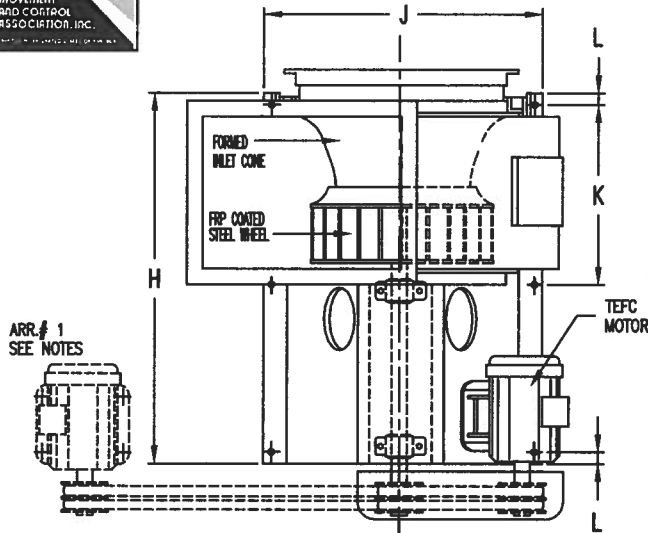

TOP VIEW

NOTES:

MOTOR CAN BE MOUNTED ON OPPOSITE SIDE OF FRAME.
USE ARRANGEMENT NO. 1 ON 40 HP MOTORS AND OVER.
BOTTOM HORIZONTAL DISCHARGE REQUIRES STEEL MODIFICATIONS.

USER:	
PURCHASER:	
DATE:	JOB NUMBER:
C.F.M.:	VENTING:
STATIC PRESSURE:	MAT. TYPE:
CLASS:	ARRANGMENT:
ROTATION:	DISCHARGE:
BHP:	FAN RPM:
MOTOR H.P.:	MOTOR RPM:
VOLTAGE:	
DRIVR SHV:	DRIVN SHV:
DRIVR BUSHNG:	DRIVN BUSHNG:
BELTS:	BEARINGS:
NOTE:	

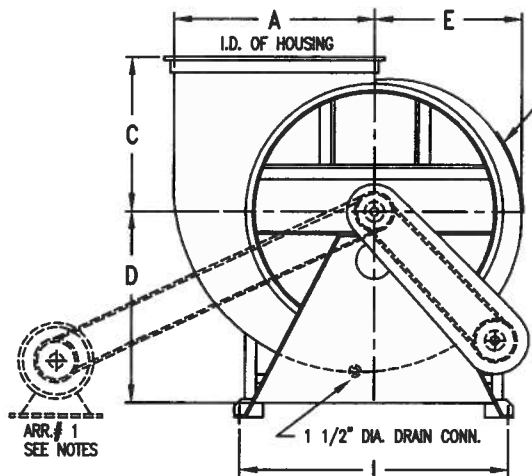

END VIEW

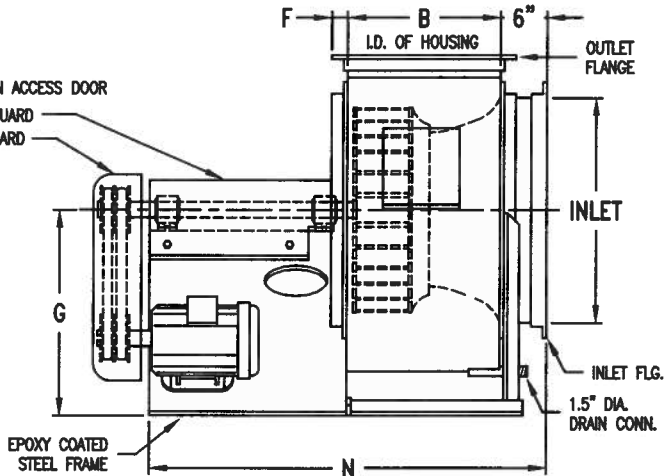

SIDE VIEW

FAN NO.	A	B	C	D	E	F	G	H	I	J	K	L	N	INLET	BOLT HOLES	SHAFT DIA.	KEYWAY IN SHAFT
12.25	12.750	9.750	10.375	11.297	9.750	1.500	14.500	26.063	19.250	21.250	12.188	1.000	30.063	13.250	.500	1.188	.250 X .125
13.5	14.000	10.750	11.063	12.359	10.625	1.500	16.000	27.063	20.250	22.250	13.313	1.000	31.063	14.625	.500	1.188	.250 X .125
15	15.625	11.750	11.875	13.703	11.688	1.500	17.500	35.000	22.000	24.000	14.313	1.000	39.000	16.250	.500	1.438	.375 X .188
16.5	17.125	13.125	12.500	14.969	12.625	1.500	19.500	38.875	23.375	25.375	15.688	1.000	42.875	17.875	.500	1.438	.375 X .188
18.25	19.000	14.500	13.687	16.609	14.031	1.500	20.500	39.750	25.000	27.000	17.063	1.000	43.750	19.750	.500	1.438	.375 X .188
20	20.875	15.875	14.813	18.188	15.375	1.500	23.500	43.125	27.500	30.000	18.938	1.250	46.625	21.625	.500	1.688	.375 X .188
22.25	23.250	17.625	16.188	20.234	17.094	1.500	25.000	45.000	31.000	33.500	20.813	1.250	48.500	24.125	.500	1.688	.375 X .188
24.5	25.500	19.500	17.563	22.281	18.813	1.500	27.000	47.500	33.125	35.625	22.563	1.250	51.000	26.500	.625	1.938	.500 X .250
27	28.125	21.500	19.500	24.594	20.750	1.500	30.000	49.500	36.250	38.750	24.563	1.250	53.000	29.250	.625	1.938	.500 X .250
30	31.250	23.750	21.000	27.594	23.031	1.500	33.000	51.875	40.000	42.500	26.938	1.250	55.375	32.500	.625	2.188	.500 X .250
33	34.375	26.250	22.813	30.000	25.313	1.500	36.000	55.500	44.000	47.000	29.938	1.500	58.500	35.625	.625	2.438	.625 X .313

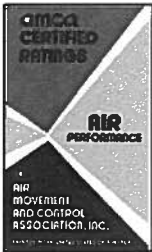

KCH Services certifies that the CI and NH Fans shown herein are licensed to bear the AMCA Seal. The ratings shown are based on tests and procedures performed in accordance with AMCA publication 211 and comply with the requirements of the AMCA Certified Ratings Program.

CENTRIFUGAL NH FAN NO.



FOREST CITY, NC - HOWE, IN

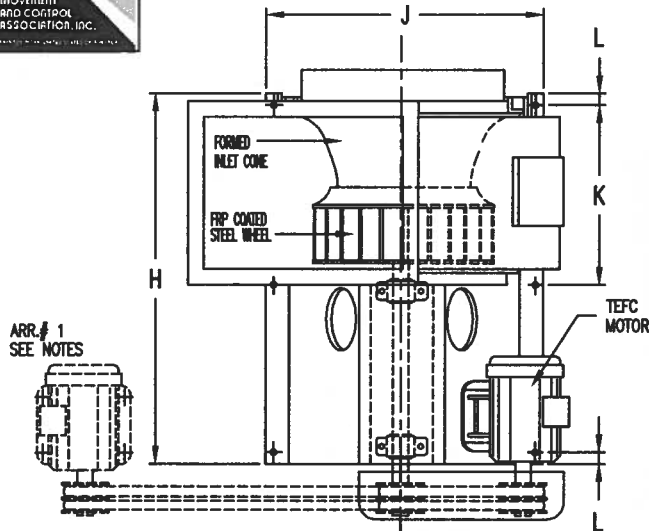

TOP VIEW

NOTES:

MOTOR CAN BE MOUNTED ON OPPOSITE SIDE OF FRAME.
 USE ARRANGEMENT NO. 1 ON 40 HP MOTORS AND OVER.
 BOTTOM HORIZONTAL DISCHARGE REQUIRES STEEL MODIFICATIONS.

USER:	
PURCHASER:	
DATE:	JOB NUMBER:
C.F.M.:	VENTING:
STATIC PRESSURE:	MAT. TYPE:
CLASS:	ARRANGMENT:
ROTATION:	DISCHARGE:
BHP:	FAN RPM:
MOTOR H.P.:	MOTOR RPM:
VOLTAGE:	
DRIVR SHV:	DRIVN SHV:
DRIVR BUSHNG:	DRIVN BUSHNG:
BELTS:	BEARINGS:
NOTE:	

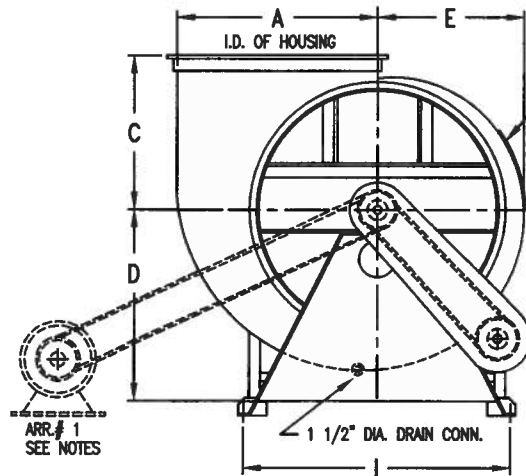

END VIEW

BOLT-ON ACCESS DOOR
 SHAFT GUARD
 BELT GUARD

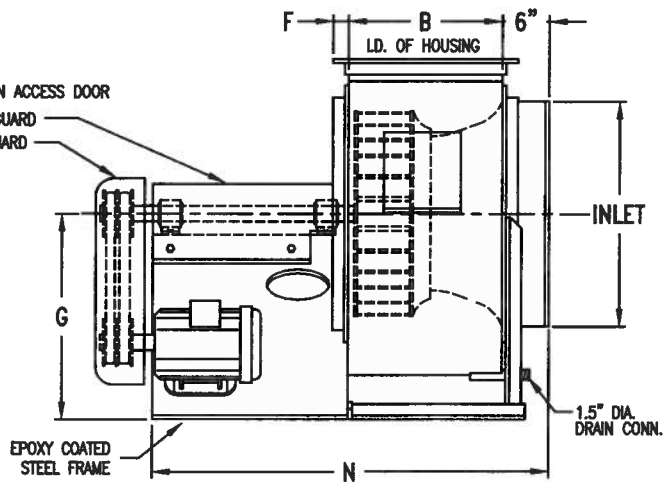

SIDE VIEW

FAN NO.	A	B	C	D	E	F	G	H	I	J	K	L	N	INLET	BOLT HOLES	SHAFT DIA.	KEYWAY IN SHAFT
36.5	38.000	29.000	25.063	33.156	28.000	1.500	40.000	59.250	48.000	51.000	32.688	1.500	62.250	38.500	.625	2.438	.625 X .313
40.25	42.000	32.000	27.938	36.594	30.875	2.000	43.750	63.000	53.000	56.000	35.750	1.500	66.000	42.500	.875	2.688	.625 X .313
44.5	46.500	35.375	30.688	40.484	34.156	2.000	44.750	66.875	58.000	61.000	39.125	1.500	69.875	47.000	.875	2.938	.750 X .375
49	51.125	39.000	34.000	44.563	37.625	2.000	48.000	77.500	64.000	67.000	41.750	1.500	80.500	51.625	.875	3.188	.750 X .375
54.25	56.500	43.125	37.188	49.313	41.625	2.000	52.000	81.500	69.000	72.000	46.875	1.500	84.500	57.250	.875	3.438	.875 X .438
60	62.500	47.750	41.188	54.594	46.063	2.000	57.750	86.000	75.000	78.000	51.500	1.500	88.000	63.250	1.000	3.938	1.000 X .500

1. EPOXY COATED STEEL FAN FRAME
2. PVC ACCESS DOOR
3. PVC HOUSING
4. PVC DRAIN COUPLING
5. KOROSEAL SHAFT SEAL
6. FRP COATED STEEL WHEEL
7. PVC INLET CONE
8. EPOXY COATED STEEL INLET SUPPORT RING
9. PVC INLET FLANGE
10. PVC OUTLET FLANGE
11. PVC PROTECTIVE BOLT CAP

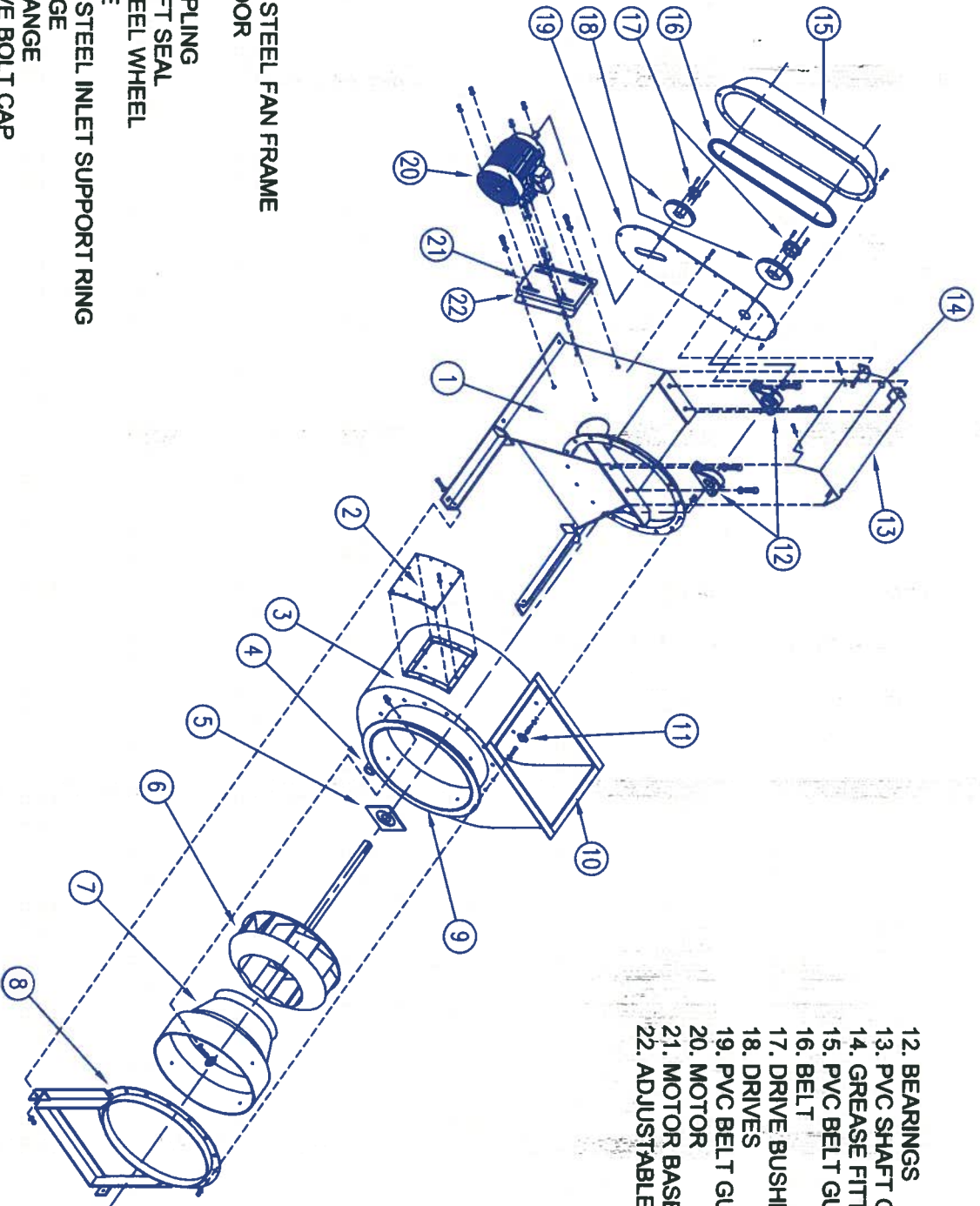

12. BEARINGS
13. PVC SHAFT GUARD
14. GREASE FITTING ACCESS HOLE
15. PVC BELT GUARD
16. BELT
17. DRIVE BUSHINGS
18. DRIVES
19. PVC BELT GUARD BACK PLATE
20. MOTOR
21. MOTOR BASE ADJUSTING BOLT
22. ADJUSTABLE MOTOR BASE

NH - SERIES BLOWER PARTS LIST

Smart Exhaust Fan

*An Energy Efficient,
Direct Driven, Adjustable Speed,
Centrifugal Fan*

100 % Corrosion Resistant

- ◆ PVC, FRP, or Polypropylene Construction
- ◆ Excellent Performance
- ◆ AMCA Rated

Variable Frequency Drive

- ◆ Adjustable Air Flow Control
- ◆ Significant Energy Savings
- ◆ Smooth Startup, Ramp Up, and Ramp Down
- ◆ Easy To Use Interface
- ◆ Computer Network Connectable
- ◆ Eliminates Motor Starters

Direct Drive Arrangement

- ◆ No Belts To Maintain and Replace
- ◆ Excellent Performance
- ◆ Zero Belt Loss
- ◆ No Pulley Cost
- ◆ Extended Bearing Life
- ◆ Extended Motor Life

*"The KCH Smart Exhaust Fan
can save thousands
of dollars on your utility bill"*
Greg Andrews—Vice President
S & S Plating

CENTRIFUGAL NH FAN NO. -

KCH FOR DIRECT DRIVE ARR. 1

USER: -
 PURCHASER: -
 DATE: - JOB NUMBER: -
 C.F.M.: - VENTING: -
 STATIC PRESSURE: " w.c. MAT. TYPE: -
 CLASS: - ARRANGMENT: 1
 ROTATION: - DISCHARGE: -
 BHP: - FAN RPM: -
 MOTOR H.P.: - MOTOR RPM: -
 VOLTAGE: -
 COUPLING: - BEARINGS: -
 NOTES: -

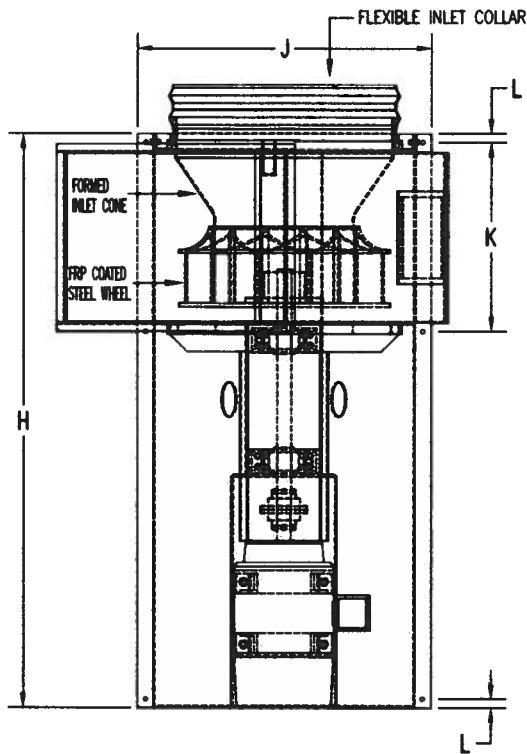

TOP VIEW

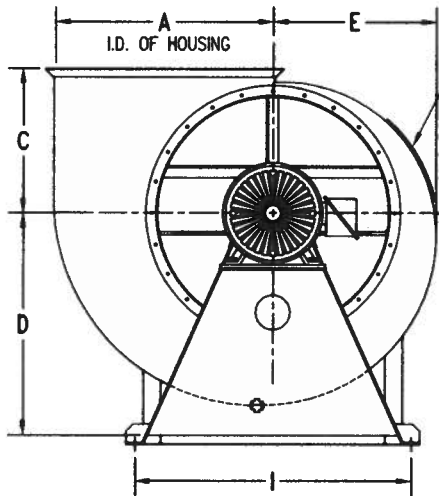

END VIEW

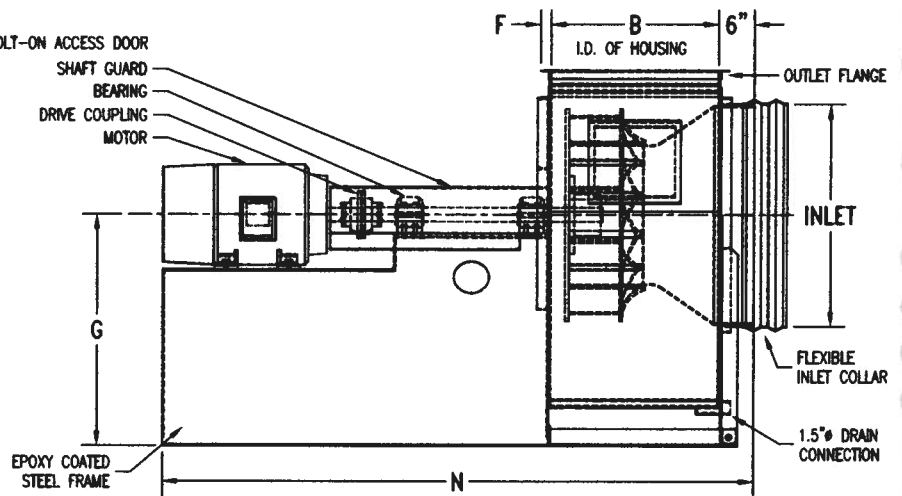

SIDE VIEW

FAN NO.	A	B	C	D	E	F	G	H	I	J	K	L	N	INLET	BOLT HOLES	SHAFT DIA.	KEYWAY IN SHAFT
12.25	12.750	9.750	10.375	11.297	9.750	1.500	14.500	57.963	19.250	21.250	12.188	1.000	61.963	13.250	.500	1.188	.250 X .125
13.5	14.000	10.750	11.063	12.359	10.625	1.500	16.000	58.963	20.250	22.250	13.313	1.000	62.963	14.625	.500	1.188	.250 X .125
15	15.625	11.750	11.875	13.703	11.688	1.500	17.500	68.400	22.000	24.000	14.313	1.000	72.400	16.250	.500	1.438	.375 X .188
16.5	17.125	13.125	12.500	14.969	12.625	1.500	19.500	74.875	23.375	25.375	15.688	1.000	78.875	17.875	.500	1.438	.375 X .188
18.25	19.000	14.500	13.687	16.809	14.031	1.500	20.500	75.750	25.000	27.000	17.063	1.000	79.750	19.750	.500	1.438	.375 X .188
20	20.875	15.875	14.813	18.188	15.375	1.500	23.500	79.125	27.500	30.000	18.938	1.250	82.625	21.625	.500	1.688	.375 X .188
22.25	23.250	17.625	16.188	20.234	17.094	1.500	25.000	83.690	31.000	33.500	20.813	1.250	87.190	24.125	.500	1.688	.375 X .188
24.5	25.500	19.500	17.563	22.281	18.813	1.500	27.000	86.190	33.125	35.625	22.563	1.250	89.690	26.500	.625	1.938	.500 X .250
27	28.125	21.500	19.500	24.594	20.750	1.500	30.000	88.190	36.250	38.750	24.563	1.250	91.690	29.250	.625	1.938	.500 X .250
30	31.250	23.750	21.000	27.594	23.031	1.500	33.000	95.815	40.000	42.500	26.938	1.250	99.315	32.500	.625	2.188	.500 X .250
33	34.375	26.250	22.813	30.000	25.313	1.500	36.000	99.440	44.000	47.000	29.938	1.500	102.440	35.625	.625	2.438	.625 X .313
36.5	38.000	29.000	25.063	33.156	28.000	1.500	40.000	109.310	48.000	51.000	32.688	1.500	112.310	38.500	.625	2.438	.625 X .313
40.25	42.000	32.000	27.938	36.594	30.875	2.000	43.750	113.060	53.000	56.000	35.750	1.500	116.060	42.500	.875	2.688	.625 X .313
44.5	46.500	35.375	30.688	40.484	34.156	2.000	44.750	116.935	58.000	61.000	39.125	1.500	119.935	47.000	.875	2.938	.750 X .375
49	51.125	39.000	34.000	44.563	37.625	2.000	48.000	127.560	64.000	67.000	41.750	1.500	130.560	51.625	.875	3.188	.750 X .375
54.25	56.500	43.125	37.188	49.313	41.625	2.000	52.000	131.560	69.000	72.000	46.875	1.500	134.560	57.250	.875	3.438	.875 X .438
60	62.500	47.750	41.188	54.594	46.063	2.000	57.750	136.060	75.000	78.000	51.500	1.500	139.060	63.250	1.000	3.938	1.000 X .500