

SWARTWOUT FIBERGLASS SERIES MODEL 912 FIBERGLASS ROUND CONTROL DAMPER Class Leakage Rated 1A

STANDARD CONSTRUCTION

FRAME

Molded fiberglass channel with angle blade stop.
Vinyl Ester Resin. See table below for dimensions.

BLADE

Fiberglass, Vinyl Ester Resin. Blade seals available for low leakage (Option)

AXLE

Pultruded fiberglass, Vinyl Ester Resin.
See table below for diameter.

BEARINGS

Molded PTFE.

CONTROL SHAFT

Axle extends 6" beyond frame.

SIZES

12", 14", 16", 18", 20", 22", 24", 26", 28", 30", 32", 36", 42", 48", 54", 60", and 66". (305, 356, 406, 457, 508, 559, 610, 660, 711, 762, 813, 914, 1067, 1219, 1372, 1524, 1676).

MAXIMUM TEMPERATURE

200°F.

MAXIMUM SYSTEM PRESSURE

10" w.g.

MAXIMUM SYSTEM VELOCITY

6000 FPM.

Dimensions in parenthesis () indicate millimeters.



Full Circumference Blade Stop (OPT)

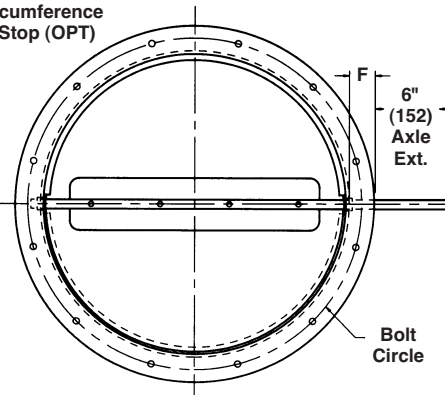

Illustrated with Optional Bolt Holes (OPT) (Face View)

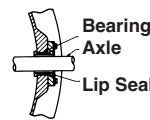
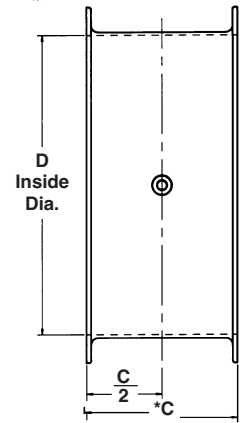

Shaft Seal (Opt.)

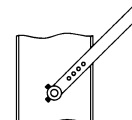

Crank Lever (CL) (Opt.)

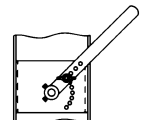

Hand Quadrant (HQ) (Opt.)

NOTES

1. Crank lever and hand quadrant constructed of 316SS.
2. Consult brochure FOVB-495 for chemical resistance chart.
3. Damper includes angle stops when blade seal option is selected.
4. All options at additional cost.
5. Standard Flanges constructed per PS15-69 Table 2.

VARIATIONS

Additional variations to those listed in table are available. Consult Ruskin for pricing.

- Wider and thicker flanges
- Exterior custom coatings
- Resins other than standard vinyl ester

"D" Inside Diameter	Frame		Blade Edge Thickness	Axle Diameter
	Flange	Web		
Sizes	Thick. X "F"	Thick. X "C"		
12-14" (305-356)	.375 x 2.187 (10 x 56)	.125 x 12 (3 x 305)	.25 (6)	1.00 (25)
16-20" (406-508)	.50 x 2.187 (13 x 56)	.125 x 12 (3 x 305)	.25 (6)	1.00 (25)
22-24" (559-610)	.50 x 2.187 (13 x 56)	.187 x 12 (5 x 305)	.25 (6)	1.00 (25)
26-36" (660-914)	.50 x 2.187 (13 x 56)	.187 x 12 (5 x 305)	.25 (6)	1.50 (38)
42" (1067)	.625 x 2.187 (16 x 56)	.25 x 12 (6 x 305)	.50 (13)	2.00 (51)
48" (1219)	.625 x 3.187 (16 x 81)	.25 x 12 (6 x 305)	.50 (13)	2.00 (51)
54-66" (1372-1676)	.625 x 3.187 (16 x 81)	.25 x 14 (6 x 356)	.50 (13)	2.00 (51)

FRAME	BLADE	BLADE SEALS (OPT)	SHAFT SEALS (OPT)	AXLE	ACCESSORIES (OPT)
MOLDED FIBERGLASS CHANNEL - SEE CONSTRUCTION TABLE	FIBERGLASS; STIFFENED AS REQUIRED	NEOPRENE	INTEGRAL WITH BEARING	FIBERGLASS ROD CONTINUOUS 6" (152) EXTENSION BEYOND FRAME	BOLT HOLES IN BOTH FLANGE
ANGLE PIN STOPS (STD)		SILICONE	AXLE SHAFT SEAL WITH OUTBOARD BEARING	316 STN. STL. (OPT)	MANUAL ACTUATOR
FULL CIRCUMFERENCE BLADE STOP (OPT)		EPDM			CL
		VITON			HQ
					ELECTRIC ACTUATOR
					PNEUMATIC ACTUATOR

QTY.	FRAME				BOLT HOLE ORIENTATION		COMMENTS	TAG
	D-DIA.	G Bolt Circle Diam.	H No. Holes	M Hole Diam.	S Straddle	T Parallel		

JOB

LOCATION

CONTRACTOR

MODEL 912 SUGGESTED SPECIFICATION

Suggested specification for Model 912 Ruskin Swartwout Fiberglass Series round dampers (revision 6394). Dampers shall be Ruskin Swartwout Series Model 912 FRP control dampers or equal.

A. Damper frames

Dampers shall be constructed with premium vinyl ester resins suitable for specified contaminants. Vinyl ester construction shall be through out, both corrosion liner and structural layers laminated using specified vinyl ester resin. Polyester, vinyl ester combinations are not acceptable. Resins used shall carry a flame spread of 25 or less. Uses of flame retardant or fillers in the corrosion liners are not acceptable. Damper frame and flange face shall have an integral corrosion barrier not less than 100 mils thick, and utilize specified resin. Additional surfacing veils should be used if required to meet or exceed corrosion resistance requirements. Corrosion liner shall be free of any inclusions, translucent and meet or exceed ASTM C 582-87. Chemical resistance shall be performed to ASTM 581-87. Tests shall be performed by independent laboratories and results available for viewing upon request.

B. Corrosion liners and Structural layers

Structural layers will be applied only after exotherm is complete from corrosion liner and shall consist of alternating layers of 1.5 oz/ft.sq. All entrapped air shall be removed in accordance with para. 6.3.4. of ASTM C 581-87. Glass to resin ratio shall be a minimum of 32-35 percent glass to a maximum of 65-67 percent resin. Structural layer of the web and flange shall be integral, secondary or cold wrapped flanges are unacceptable. Lamination of the structural layer and flanges shall not produce excessive shrink and or exotherm causing pre-release, or warpage to the flange face, or damper I.D. Flange face to face tolerance shall be no more than 1/16 of an inch, flange flatness (when measured on a flat surface) shall have no deviation, insuring proper bolt up to mating flanges. Post applied paraffinated gel coat will be standard.

C. Flanges

Flanges shall be routed to provide a concentric flange O.D not to deviate from out of round no more than 1/8 of an inch. Damper frame shall meet 90% barcol of resin manufacturers requirements per ASTM D 2583. Flange lamination shall be continuous, pour type flanges are not acceptable.

D. Damper and Blade design

Damper design shall be of single blade construction and center pivoted. Blades shall utilize coring material of either balsa or synthetic type centered in blade laminate. Add on or external stiffeners are not acceptable. Coring and lamination schedule

shall be designed to hold blade deflection to a minimum of L/360 on dampers with seals and L/180 on dampers without seals.

E. Axle and Bearings

A full length axle shall be permanently fastened to the blade centerline by using 316 grade stainless steel pins imbedded internally and not exposed to airstream contaminants. Two part epoxies shall be utilized for additional bonding strength. Axles shall be located on damper blade center by means of an axle saddle integrally molded in the blade surface. Axle shall be supported on both the drive and non powered side of the damper by means of a graphite filled PTFE machined bearing. Bearing to be flanged one end eliminating blade side to side motion during rotation. Vertical axle installation will require additional ring retainer supports.

Bearing support area will be no less than 5/8" thick as measured on the damper centerline. Support pads will be molded directly to the damper exterior. Manufacturer certification of bearing material and machining will be available upon request. Axle will be constructed of a premium grade vinyl ester and conform to ASTM D 435-84a.

F. Blade Seals

Blade edge seals shall be of the "Single Tadpole" or Double design depending on pressures. Seal to be mechanically fastened to the blade perimeter using FRP retainer and Isoplast™ fasteners. Seal will be continuous and not break at axle. Blade seal will not be compressed against a blade stop. Blade seal will be of the wiper design. Seal and cored blade combination installed in damper frame shall meet or exceed 1.37 cfm leakage @10" w.g. static pressure for Model 912. Damper assembly to be leak tested in both directions. Damper shall bear the AMCA label for Air Leakage in accordance to AMCA standard 511. Damper holding torque shall not exceed 181 inch pounds total to keep damper in the closed position during testing.

G. Shaft Seals

If required, axle shaft seals will be of the spring loaded single lip, double lip or "O" ring type seal housed in an FRP composite retainer. The use of PVC, UHMW and other Thermoplastics are not acceptable. Seal type selection shall be based on application and material availability. Seal shall be easily maintainable and not hinder damper axle rotation. Each shaft diameters will have dedicated axle seal. Use of flat stock elastomers for axle seals are not acceptable. Hand actuation devices will be designed to provide access for seal inspection or replacement.

LEAKAGE*	
Static Pressure (inches W.G.)	CFM/Sq. Ft.
10"	1.37

*Chart reflects results with damper bearings installed downstream. If dampers are installed with bearings upstream, multiply leakage rate by 2.

PRESSURE LIMITATIONS

Damper Dia.	Max. System Pressure	Max. System Velocity
66" (1676)	10"	6000 fpm
60" (1524)	10"	6000 fpm
48" (1219)	10"	6000 fpm
36" (914)	10"	6000 fpm
24" (610)	10"	6000 fpm
12" (305)	10"	6000 fpm

MODEL 912 PERFORMANCE DATA

Damper Diameter Inches (mm)	1 in. W.G.	4 in. W.G.	8 in. W.G.
12" (305) through 66" (1676)	1A	1	1

Class 1A =
3 CFM Sq. Ft. @ 1" w.g.

Class 1 =
4 CFM Sq. Ft. @ 1" w.g.
8 CFM Sq. Ft. @ 4" w.g.
11 CFM Sq. Ft. @ 8" w.g.

Dampers may tolerate higher pressure and velocities than those indicated here. Conservative ratings are presented intentionally in an effort to avoid misapplication. Consult Ruskin or your Ruskin representative when damper is to be applied in conditions exceeding recommended maximums.

Performance curves based on AMCA Standard 500D. Air leakage is based on operation between 50°F to 104°F (10°C to 40°C). All data corrected to represent standard air density 0.075 lbs/ft³.

Minimum torque applied holding damper closed – 181 inch lbs.

Pressure drop and leakage information is for unit equipped with full circumference blade seal. Consult Ruskin for data when unit equipped with full circumference blade stop.



Ruskin company certifies that the Model 912 shown herein is licensed to bear the AMCA Seal. The ratings shown are based on tests and procedures performed in accordance with AMCA Publication 511, and comply with the requirements of the AMCA Certified Ratings Program. The AMCA International Certified Ratings Seal applies to Air Performance and Air Leakage.

Model 912 Damper size 12" Dia. Velocity vs. Pressure Drop

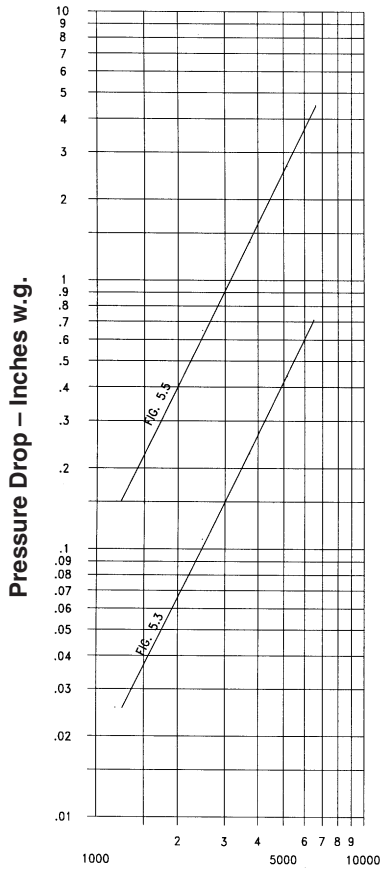

Model 912 Damper size 24" Dia. Velocity vs. Pressure Drop

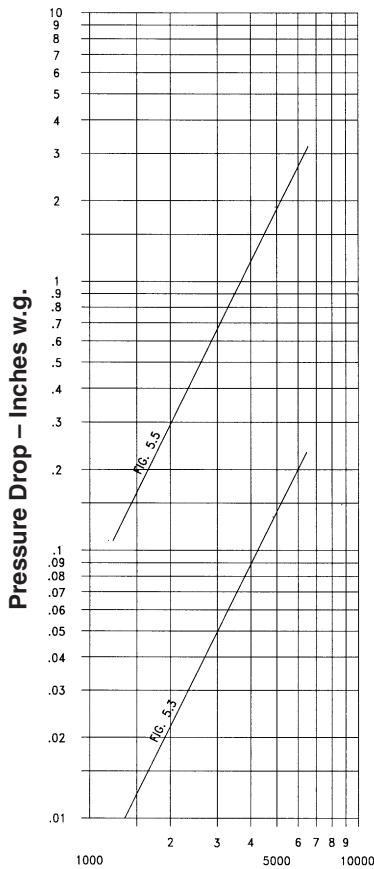

Model 912 Damper size 36" Dia. Velocity vs. Pressure Drop

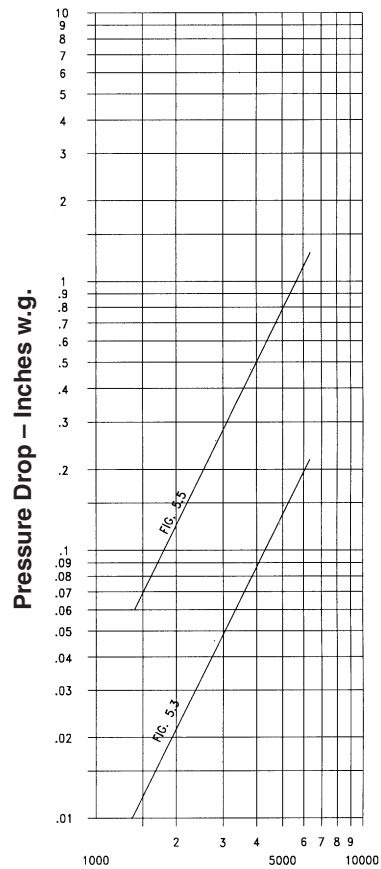

AMCA FIGURE 5.3

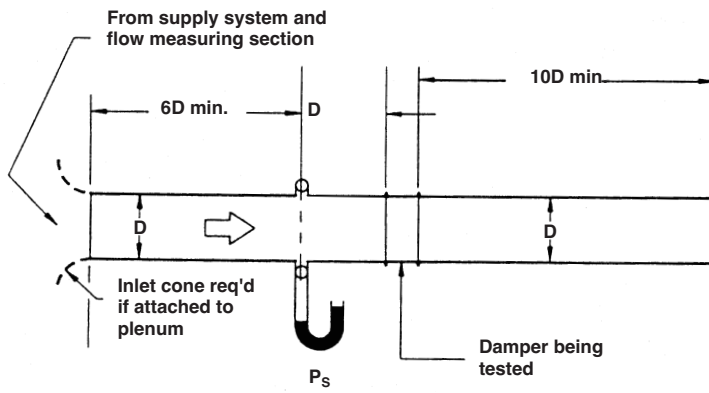

AMCA STANDARD 500
 FIGURE 5.3 DAMPER TEST SETUP WITH INLET AND OUTLET DUCTS

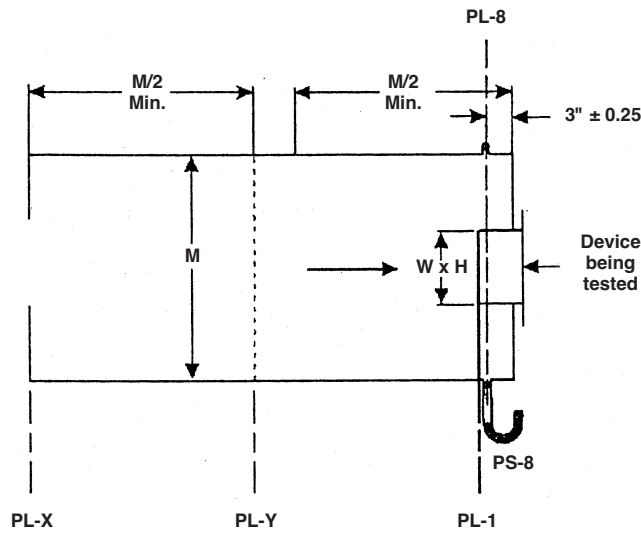

ALTERNATE MOUNT B (LEAKAGE TEST ONLY)
 FIGURE 5.5 TEST DEVICE SETUP WITH INLET CHAMBER