

Model DFDAF-330 Multi-blade FIRE DAMPER

Steel Airfoil Blades
UL555 3 Hour Fire Resistance Rating

Application

Model DFDAF-330 is a multi-blade fire damper with airflow style blades. The DFDAF-330 is qualified to 4000 fpm (20.3 m/s) and 8 in. wg (2 kPa) for dynamic closure in emergency fire situations. Model DFDAF-330 may be installed vertically or horizontally (with blades running horizontal) and is rated for airflow in either directions.

Ratings

UL 555 Fire Resistance Rating:

Fire Rating: 3 hour
Dynamic Closure Rating: Actual ratings are size dependent
Maximum Velocity: 4000 fpm (20.3 m/s) up to
 30 in. x 48 in. (762mm x 1219mm)
 2000 fpm (10.2 m/s) sizes greater than
 32 in. x 36 in. (813mm x 914mm)
Maximum Pressure: 8 in. wg (2 kPa)

Model DFDAF-330 meets the requirements for fire dampers established by:

National Fire Protection Association
 NFPA Standards 80, 90A & 101
IBC International Building Codes

“UL CLASSIFIED (see complete marking on product)”

“UL CLASSIFIED to Canadian safety standards (see complete marking on product)”
 Standard 555 (Listing #R13317)

Construction	Standard	Optional
Frame Material	Galvanized steel	-
Frame Material Thickness	16 ga. (1.5mm)	-
Frame Type	5 in. x 1 in. (127mm x 25mm) hat channel	-
Blade Material	Galvanized steel	-
Blade Material Thickness	14 ga. (2mm) equivalent	-
Blade Type	Double skin airfoil	-
Linkage	Plated steel out of airstream, concealed in jamb	-
Axle Bearings	304SS	-
Axle Material	Plated steel	-
Jamb Seals	304SS	-
Closure Device	Fusible link	-
Closure Temperature	165°F (74°C)	212°F (100°C), 286°F (141°C), 350°F (177°C)
Actuator	Manual quadrant	-

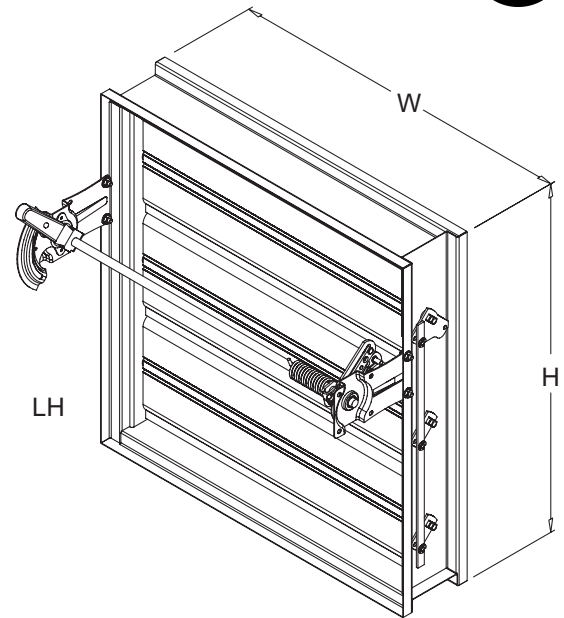

W x H	Minimum Size	Maximum Size		
		Single Section	Multi-Section	
			2000 fpm (10.2 m/s)	4000 fpm (20.3 m/s)
Inches	8 x 6	32 x 36 (V) or 30 x 48 (H or V)	120 x 96 (V or H)	30 x 48 (V)
mm	203 x 152	813 x 914 or 762 x 1219	3048 x 2438 (V) or 3658 x 2438 (H)	762 x 1219 (V)

*W & H dimensions furnished approximately 1/4 in. (6 mm) undersize.
 (Add sleeve thickness for overall sleeved damper dimension)
 Right hand drive is shown. Left hand drive is available upon request.

Features

- Frames are constructed with reinforced corners. Low profile head and sill are used on sizes less than 17 in. (432mm) high.
- Blades are double skin airfoil shape of galvanized steel with full length structural reinforcement.

Options available for DFDAF-330:

- Extra Fusible Links
- Factory mounted accessories
 - Retaining angles
- Flanges
- OCI (Open Closed Indication switches): Units will be supplied with one OCI per row of damper sections
- POC retaining angles
- Sealed transition and sleeves
- Sleeves
- Transitions (R and C)

Pressure Drop Data

This pressure drop testing was conducted in accordance with AMCA Standard 500-D using the three configurations shown. All data has been corrected to represent standard air at a density of .075 lb/ft³(1.201 kg/m³).

Actual pressure drop found in any HVAC system is a combination of many factors. This pressure drop information along with an analysis of other system influences should be used to estimate actual pressure losses for a damper installed in a given HVAC system.

AMCA Test Figures

Figure 5.3 Illustrates a fully ducted damper. This configuration has the lowest pressure drop of the three test configurations because entrance and exit losses are minimized by straight duct runs upstream and downstream of the damper.

Figure 5.2 Illustrates a ducted damper exhausting air into an open area. This configuration has a lower pressure drop than Figure 5.5 because entrance losses are minimized by a straight duct run upstream of the damper.

Figure 5.5 Illustrates a plenum mounted damper. This configuration has the highest pressure drop because of extremely high entrance and exit losses due to the sudden changes of area in the system.

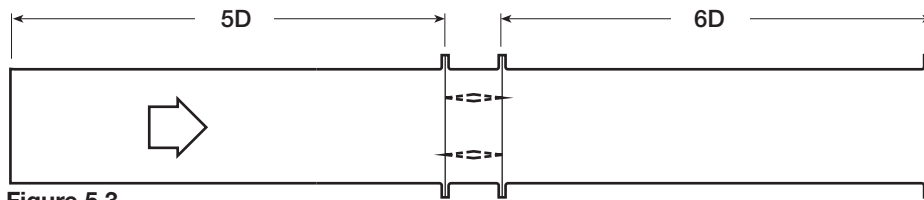

Figure 5.3

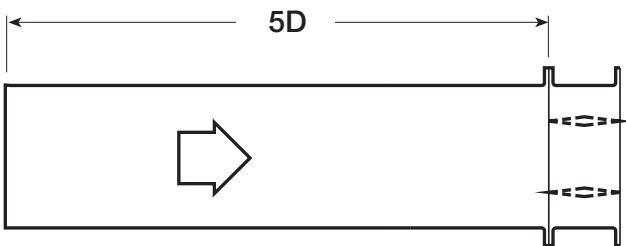

Figure 5.2

$$D = \sqrt{\frac{4(W)(H)}{3.14}}$$

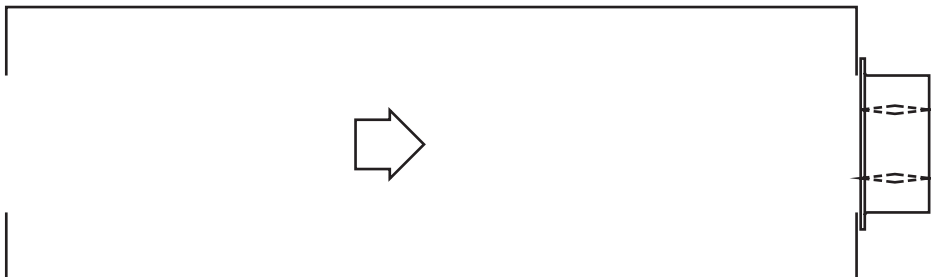

Figure 5.5

AMCA Figure 5.2

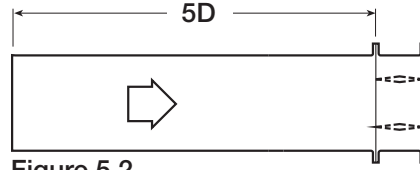

Figure 5.2

12 in. x 12 in. (305mm x 305mm)

Velocity (fpm)	Pressure Drop (in. wg)
500	0.03
1000	0.12
1500	0.26
2000	0.46
2500	0.72
3000	1.04
3500	1.41
4000	1.84

24 in. x 24 in. (610mm x 610mm)

Velocity (fpm)	Pressure Drop (in. wg)
500	0.01
1000	0.06
1500	0.12
2000	0.22
2500	0.34
3000	0.49
3500	0.67
4000	0.87

36 in. x 36 in. (914mm x 914mm)

Velocity (fpm)	Pressure Drop (in. wg)
500	0.01
1000	0.06
1500	0.12
2000	0.22
2500	0.34
3000	0.49
3500	0.67
4000	0.88

12 in. X 48 in. (305mm x 1219mm)

Velocity (fpm)	Pressure Drop (in. wg)
500	0.01
1000	0.05
1500	0.12
2000	0.21
2500	0.33
3000	0.48
3500	0.65
4000	0.85

48 in. x 12 in. (1219mm x 305mm)

Velocity (fpm)	Pressure Drop (in. wg)
500	0.02
1000	0.08
1500	0.18
2000	0.33
2500	0.51
3000	0.74
3500	1.00
4000	1.31

AMCA Figure 5.3

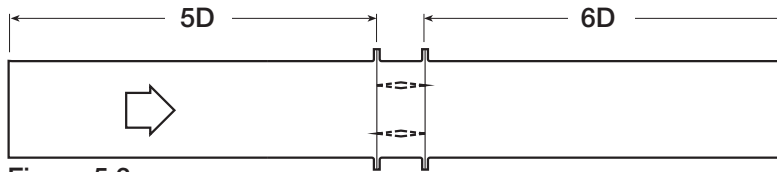

Figure 5.3

12 in. x 12 in. (305mm x 305mm)

Velocity (fpm)	Pressure Drop (in. wg)
500	0.01
1000	0.06
1500	0.13
2000	0.23
2500	0.37
3000	0.53
3500	0.73
4000	0.95

24 in. x 24 in. (610mm x 610mm)

Velocity (fpm)	Pressure Drop (in. wg)
500	0.01
1000	0.02
1500	0.06
2000	0.10
2500	0.16
3000	0.23
3500	0.32
4000	0.42

36 in. x 36 in. (914mm x 914mm)

Velocity (fpm)	Pressure Drop (in. wg)
500	0.01
1000	0.02
1500	0.05
2000	0.09
2500	0.14
3000	0.21
3500	0.29
4000	0.38

12 in. X 48 in. (305mm x 1219mm)

Velocity (fpm)	Pressure Drop (in. wg)
500	0.01
1000	0.02
1500	0.06
2000	0.10
2500	0.16
3000	0.24
3500	0.33
4000	0.43

48 in. x 12 in. (1219mm x 305mm)

Velocity (fpm)	Pressure Drop (in. wg)
500	0.01
1000	0.04
1500	0.10
2000	0.18
2500	0.29
3000	0.42
3500	0.57
4000	0.74

AMCA Figure 5.5

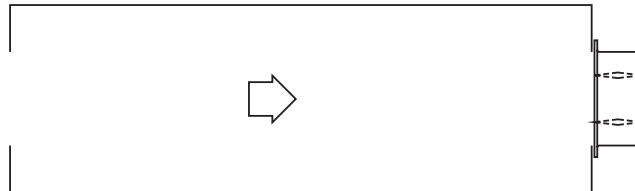

12 in. x 12 in. (305mm x 305mm)

Velocity (fpm)	Pressure Drop (in. wg)
500	0.04
1000	0.18
1500	0.42
2000	0.75
2500	1.17
3000	1.68
3500	2.29
4000	2.09

24 in. x 24 in. (610mm x 610mm)

Velocity (fpm)	Pressure Drop (in. wg)
500	0.03
1000	0.13
1500	0.29
2000	0.52
2500	0.81
3000	1.17
3500	1.60
4000	2.14

36 in. x 36 in. (914mm x 914mm)

Velocity (fpm)	Pressure Drop (in. wg)
500	0.03
1000	0.12
1500	0.27
2000	0.48
2500	0.75
3000	1.08
3500	1.48
4000	1.93

12 in. X 48 in. (305mm x 1219mm)

Velocity (fpm)	Pressure Drop (in. wg)
500	0.03
1000	0.12
1500	0.27
2000	0.49
2500	0.77
3000	1.11
3500	1.51
4000	1.97

48 in. x 12 in. (1219mm x 305mm)

Velocity (fpm)	Pressure Drop (in. wg)
500	0.03
1000	0.14
1500	0.32
2000	0.57
2500	0.89
3000	1.28
3500	1.75
4000	2.29



Greenheck India Private Limited certifies that the model DFDAF-330 shown herein is licensed to bear the AMCA Seal. The ratings shown are based on tests and procedures performed in accordance with AMCA Publication 511 and comply with the requirements of the AMCA Certified Ratings Programs. The AMCA Certified Ratings Seal applies to air performance ratings only.

Damper Sizing Information

Dampers larger than maximum single section size are supplied as a factory assembly of two or more sections of equal size. The following figures show maximum damper section size and assembly configurations for multi-section dampers. Larger damper sizes may ship in multiple sections.

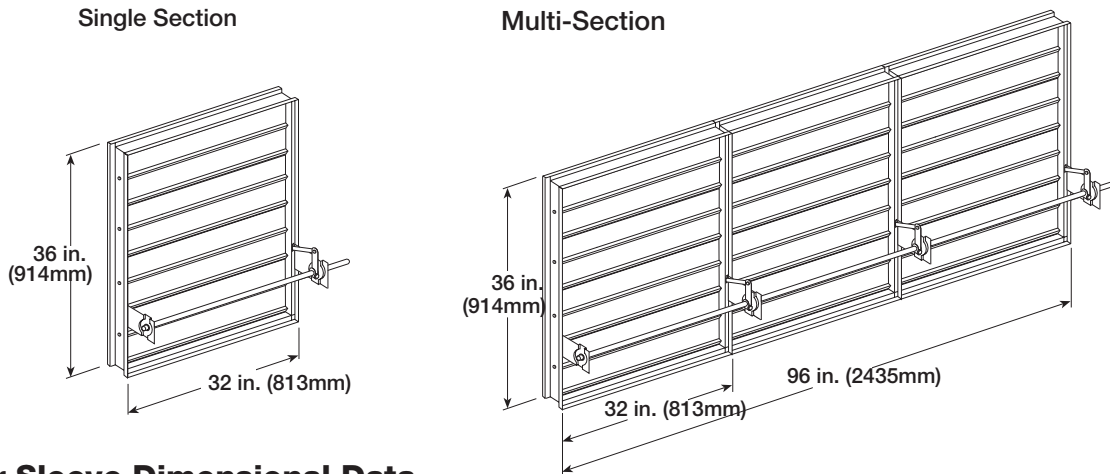

Damper Sleeve Dimensional Data

The drawings below and corresponding table show the position of the DFDAF-330 damper when mounted in a factory sleeve. The standard mounting locations provide enough space for the mounting of manual quadrant, controls and allow space for installation of retaining angles and duct connections.

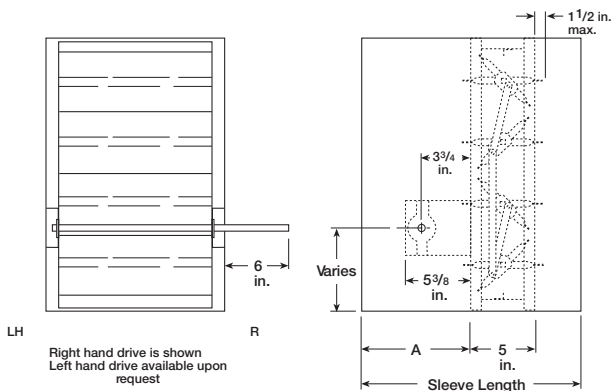

The "A" dimension is the location of the damper mounted in a factory sleeve. The table below shows the Standard and Maximum "A" dimensions.

in. (mm)	"A" Dimension	
	Standard	Maximum
All Dampers	7 3/16 (183)	12 (305)
When H is 10 in. (254mm) or less with OCI	12 (305)	12 (305)

*With the exception of dampers 10 in. high (254mm) or less.
NOTE: Entire damper frame is not required to be installed within the wall. The damper blades, when closed should be contained within the wall.

All dimensions shown are in inches.

Specifications

Fire Dampers meeting the following specifications shall be furnished and installed where shown on plans and/or as described in schedules. Dampers shall meet the requirements of the latest edition of NFPA 80, 90A and 101.

Dampers shall be tested, rated and labeled in accordance with the latest edition of UL Standard 555. Dampers shall have a UL 555 fire rating of 3 hours. Each damper shall be equipped with a heat responsive device which has been tested and approved for use with the damper assembly in accordance with UL 555. The heat responsive device shall have a temperature rating of (specifier select one of the following) 165°F (74°C), 212°F (100°C), 286°F (141°C), or 350°F (177°C).

Dampers shall be UL labeled for use in dynamic systems. The damper shall have a dynamic closure pressure rating of 4 in. wg (1 kPa) or 8 in. wg (2 kPa). UL 555 Dynamic Closure Ratings shall be qualified for airflow and pressure in either direction through the damper. UL ratings shall allow for mounting damper vertically (with blades running horizontal) or horizontally.

Damper actuator shall be manual quadrant. Manufacturer's submittal data shall indicate actuator space requirements around the damper.

Damper blades shall be 14 ga. (2mm) galvanized steel airfoil style. Blades shall be completely symmetrical relative to their axle pivot point, presenting identical resistance to airflow and operation in either direction through the damper (blades that are non-symmetrical relative to their axle pivot point or utilize blade stops larger than 1/2 in. (13mm) are unacceptable).

Damper frame shall be 16 ga. (1.5mm) galvanized steel formed into a structural hat channel shape with reinforced corners. Bearings shall be 304SS type rotating in extruded holes in the damper frame for maximum service. Axles shall be square and positively locked into the damper blade. Jamb seals shall be stainless steel compression type.

Testing and ratings to be in accordance with AMCA standard 500-D. Basis of design is Greenheck Model DFDAF-330.

