

Combination Fire Smoke Dampers

Steel Airfoil Blades

UL555S Leakage Class I

UL555 3 Hour Fire Resistance Rating

Application

Model FSD-331 is a high performance combination fire smoke damper with Class I leakage. High strength airfoil blades ensure the lowest resistance to airflow in HVAC systems with velocities to 4000 fpm (20.3 m/s) and pressures up to 8 in. wg (2kPa). Model FSD-331 may be installed vertically or horizontally (with blades running horizontal) and is rated for airflow and leakage in either direction.

Ratings

UL555 Fire Resistance Rating

Fire Rating: 3 hours
 Dynamic Closure Rating: Actual ratings are size dependent
 Maximum Velocity: 4000 fpm (20.3 m/s)
 Maximum Pressure: 8 in. wg (2 kPa)

UL555S Leakage Rating

Leakage Class: I
 Operational Rating: Actual ratings are actuator dependent
 Maximum Velocity: 4000 fpm (20.3 m/s)
 Maximum Pressure: 8 in. wg (2 kPa)
 Maximum Temperature: 350°F (177°C) - depending on actuator

Construction	Standard	Optional
Frame Material	Galvanized steel	-
Frame Material Thickness	16 ga. (1.5mm)	-
Frame Type	5 in. x 1 in. (127mm x 25mm) hat channel	-
Blade Material	Galvanized steel	-
Blade Material Thickness	Double Skin 14 ga. (2mm) equivalent	-
Blade Type	Airfoil	-
Linkage	Plated steel out of airstream, concealed in jamb	-
Axle Bearings	304SS	-
Axle Material	Plated steel	-
Blade Seals	Silicone	-
Jamb Seals	304SS	-
Closure Device	RRL	RRL/OCI, TOR, PRV, or Fusible Link
Closure Temperature	165°F (74°C)	212°F (100°C), 250°F (121°C), 350°F (177°C)

W x H	Minimum Size	Maximum Size	
		Single Section	Multiple Section
Inches	8 x 6	32 x 36 (V) or 30 x 48 (H or V)	120 x 96 (V or H) or
mm	203 x 152	813 x 1270 (V) or 762 x 1219 (H or V)	3048 x 2438 (V) or 3658 x 2438 (H)

Note: Maximum sizes are dependent on velocities and pressures.

Model FSD-331 meets the requirements for fire dampers established by:

National Fire Protection Association

NFPA Standards 80, 90A, 92A, 92B, 101 & 105

IBC International Building Codes

“UL CLASSIFIED (see complete marking on product)”

“UL CLASSIFIED to Canadian safety standards (see complete marking on product)”

Standard 555 & 555S (Listing #R13317)

FM Approvals
 SPECIFICATION TESTED PRODUCT
 (OPTION)

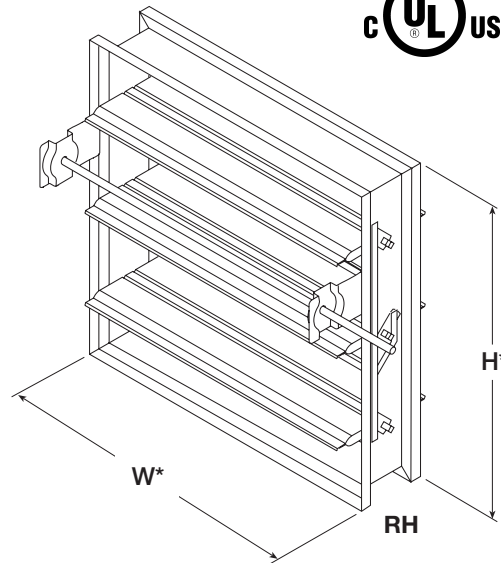

*Width and Height dimensions furnished approximately 1/4 in. (6mm) undersize. (Add sleeve thickness for overall sleeved damper dimension). Right hand drive is shown. Left hand is available upon request.

Features

- Frames are constructed with reinforced corners. Low profile head and sill are used on sizes less than 17 in. high (432mm).
- Blades are double skin airfoil shape of galvanized steel with full length structural reinforcement.

Installation instructions available at www.greenheck.com.

Options

- Actuators: 24V, 230V
- Factory mounted accessories
 - Retaining angles
- POC retaining angles
- Sealed transitions and sleeves
- Transitions : R and C

Pressure Drop Data

This pressure drop testing was conducted in accordance with AMCA Standard 500-D using the three configurations shown. All data has been corrected to represent standard air at a density of .075 lb/ft³ (1.201 kg/m³).

Actual pressure drop found in any HVAC system in a combination of many factors. This pressure drop information along with an analysis of other system influences should be used to estimate actual pressure losses for a damper installed in a given HVAC system.

AMCA Test Figures

Figure 5.3 illustrates a fully ducted damper. This configuration has the lowest pressure drop of the three test configurations because entrance and exit losses are minimized by straight duct runs upstream and downstream of the damper.

Figure 5.2 illustrates a ducted damper exhausting air into an open area. This configuration has a lower pressure drop than Figure 5.5 because entrance losses are minimized by a straight duct run upstream of the damper.

Figure 5.5 illustrates a plenum mounted damper. This configuration has the highest pressure drop because of extremely high entrance and exit losses due to the sudden changes of area in the system.

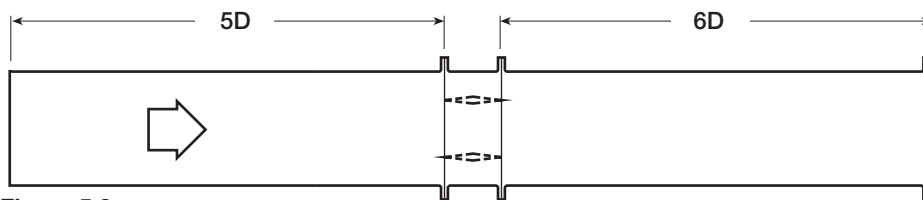

Figure 5.3

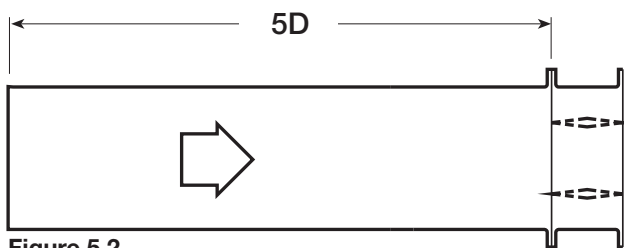

Figure 5.2

$$D = \sqrt{\frac{4(W)(H)}{3.14}}$$

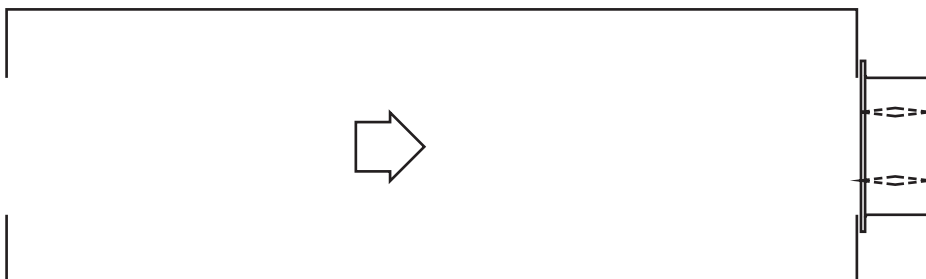
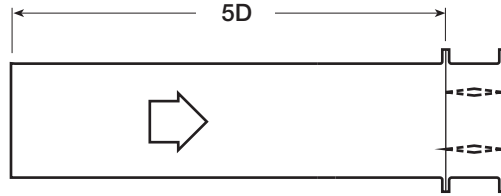

Figure 5.5

Pressure Drop

FSD-331

AMCA Figure 5.2



12 in. x 12 in. (305mm x 305mm)

Velocity (fpm)	Pressure Drop (in. wg)
500	0.03
1000	0.12
1500	0.26
2000	0.46
2500	0.72
3000	1.04
3500	1.41
4000	1.84

24 in. x 24 in. (610mm x 610mm)

Velocity (fpm)	Pressure Drop (in. wg)
500	0.01
1000	0.06
1500	0.12
2000	0.22
2500	0.34
3000	0.49
3500	0.67
4000	0.87

36 in. x 36 in. (914mm x 914mm)

Velocity (fpm)	Pressure Drop (in. wg)
500	0.01
1000	0.06
1500	0.12
2000	0.22
2500	0.34
3000	0.49
3500	0.67
4000	0.88

12in. X 48 in. (305mm x 1219mm)

Velocity (fpm)	Pressure Drop (in. wg)
500	0.01
1000	0.05
1500	0.12
2000	0.21
2500	0.33
3000	0.48
3500	0.65
4000	0.85

48 in. x 12 in. (1219mm x 305mm)

Velocity (fpm)	Pressure Drop (in. wg)
500	0.02
1000	0.08
1500	0.18
2000	0.33
2500	0.51
3000	0.74
3500	1.00
4000	1.31

AMCA Figure 5.3

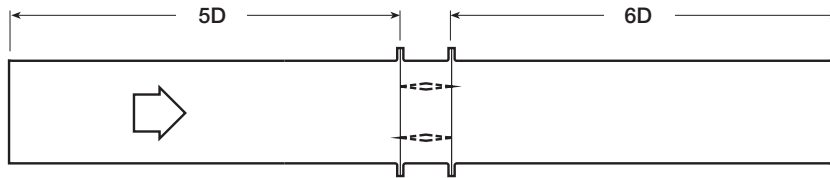

12 in. x 12 in. (305mm x 305mm)

Velocity (fpm)	Pressure Drop (in. wg)
500	0.01
1000	0.06
1500	0.13
2000	0.23
2500	0.37
3000	0.53
3500	0.73
4000	0.95

24 in. x 24 in. (610mm x 610mm)

Velocity (fpm)	Pressure Drop (in. wg)
500	0.01
1000	0.02
1500	0.06
2000	0.10
2500	0.16
3000	0.23
3500	0.32
4000	0.42

36 in. x 36 in. (914mm x 914mm)

Velocity (fpm)	Pressure Drop (in. wg)
500	0.01
1000	0.02
1500	0.05
2000	0.09
2500	0.14
3000	0.21
3500	0.29
4000	0.38

12in. X 48 in. (305mm x 1219mm)

Velocity (fpm)	Pressure Drop (in. wg)
500	0.01
1000	0.02
1500	0.06
2000	0.10
2500	0.16
3000	0.24
3500	0.33
4000	0.43

48 in. x 12 in. (1219mm x 305mm)

Velocity (fpm)	Pressure Drop (in. wg)
500	0.01
1000	0.04
1500	0.10
2000	0.18
2500	0.29
3000	0.42
3500	0.57
4000	0.74

AMCA Figure 5.5

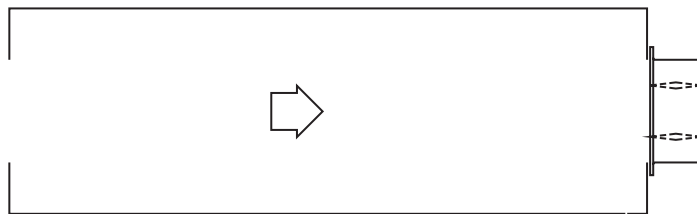

12 in. x 12 in. (305mm x 305mm)

Velocity (fpm)	Pressure Drop (in. wg)
500	0.04
1000	0.18
1500	0.42
2000	0.75
2500	1.17
3000	1.68
3500	2.29
4000	2.09

24 in. x 24 in. (610mm x 610mm)

Velocity (fpm)	Pressure Drop (in. wg)
500	0.03
1000	0.13
1500	0.29
2000	0.52
2500	0.81
3000	1.17
3500	1.60
4000	2.14

36 in. x 36 in. (914mm x 914mm)

Velocity (fpm)	Pressure Drop (in. wg)
500	0.03
1000	0.12
1500	0.27
2000	0.48
2500	0.75
3000	1.08
3500	1.48
4000	1.93

12in. X 48 in. (305mm x 1219mm)

Velocity (fpm)	Pressure Drop (in. wg)
500	0.03
1000	0.12
1500	0.27
2000	0.49
2500	0.77
3000	1.11
3500	1.51
4000	1.97

48 in. x 12 in. (1219mm x 305mm)

Velocity (fpm)	Pressure Drop (in. wg)
500	0.03
1000	0.14
1500	0.32
2000	0.57
2500	0.89
3000	1.28
3500	1.75
4000	2.29



Greenheck India Private Limited certifies that the model FSD-331 shown herein is licensed to bear the AMCA seal. The ratings shown are based on tests and procedures performed in accordance with AMCA Publication 511 and comply with the requirements of the AMCA Certified Ratings Programs. The AMCA Certified Ratings Seal applies to air performance ratings only.

Actuators and Accessories Space Envelopes

Externally mounted actuators always require space outside of the damper sleeve. The “S” dimension illustrates the clearance required for various available actuators.

On damper less than 18 in. (457mm), actuators may also require clearances above and/or below the sleeve. “B” and “T” dimensions are worst case clearance requirements for some dampers less than 18 in. (457mm) high. All damper sizes under 18 in. (457mm) high do not require these worst case clearances. If space availability above or below the damper sleeve is limited, each damper size should be individually evaluated.

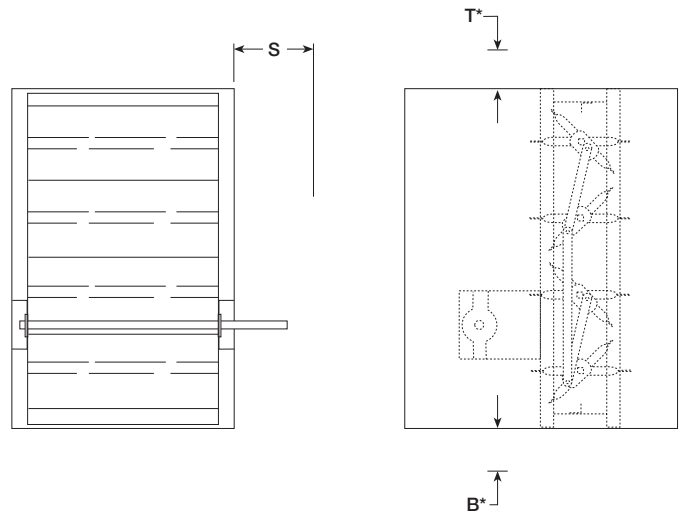

Actuator Type/Model	B*	T*	S	
	With RRL, RRL/OCI, or TOR	With RRL, RRL/OCI, or TOR	PiggyBack	
			No	Yes
24 Volt AC				
FSAF24 (-S) Belimo	12 3/4 in. (324mm)	0	6 in. (152mm)	NA
FSAF24-BAL (-S) Belimo	12 3/4 in. (324mm)	0	6 in. (152mm)	NA
FSLF24 (-S) Belimo	3 1/2 in (89mm)	0	6 in. (152mm)	NA
FSNF24 (-S) Belimo	12 3/4 in. (324mm)	0	6 in. (152mm)	9 in. (229mm)
ML8XXX Series Honeywell	4 3/4 in. (121mm)	0	6 in. (152mm)	NA
MS8X09 Series Honeywell	4 3/4 in. (121mm)	0	6 in. (152mm)	NA
MS8120 Series Honeywell	12 3/4 in. (324mm)	0	6 in. (152mm)	9 in. (229mm)
230 Volt AC				
FSLF230 (-S) Belimo	3 1/2 in (89mm)	0	6 in. (152mm)	NA
FSNF230 (-S) Belimo	12 3/4 in. (324mm)	0	6 in. (152mm)	9 in. (229mm)
ML4XXX Series Honeywell	4 3/4 in. (121mm)	0	6 in. (152mm)	NA
MS4X09 Series Honeywell	4 3/4 in. (121mm)	0	6 in. (152mm)	NA
MS4620 Series Honeywell	12 3/4 in. (324mm)	0	6 in. (152mm)	9 in. (229mm)

* For dampers 18 in. (457mm) or more in height these dimensions are 0 in. .

Damper Sleeve Dimensional Data

The drawings below and corresponding table show the position of the FSD-331 damper when mounted in a factory sleeve. The standard mounting locations provide enough space for the mounting of actuators, controls and allow space for installation of retaining angles and duct connections.

The standard location of a damper mounted in a factory sleeve ("A" dimension) is shown below. The damper can be positioned at other locations within a range of 6 in. (152mm) to 12 in. (305mm) for the "A" dimension.

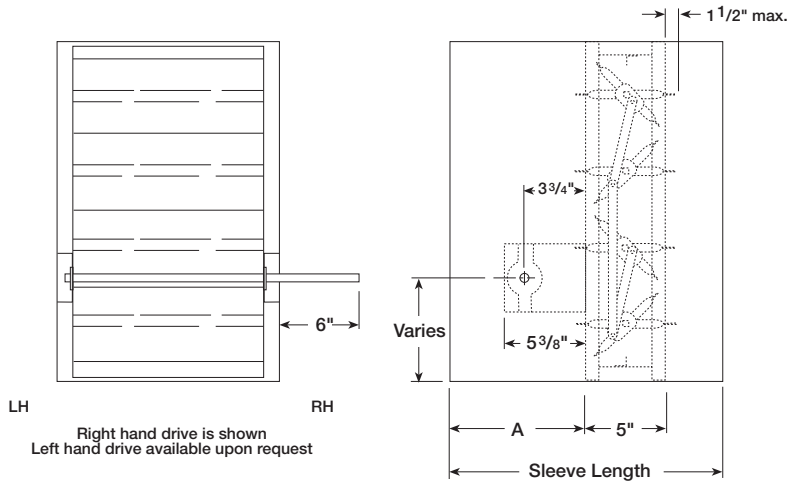

in. (mm)	"A" Dimension	
	Standard	Maximum
All Dampers*	7 3/16 (183)	12 (305)
When H is 11 in. (279mm) or less with OCI, RRL, or TOR	12 (305)	12 (305)

*With the exception of dampers 10 in. high (254mm) or less. NOTE: Entire damper frame is not required to be installed within the wall. The damper blades, when closed should be contained within the wall.

Damper Sizing Information

Dampers larger than maximum single section size are supplied as a factory assembly of two or more sections of equal size. The following figures show maximum damper section size and assembly configurations for multi-section dampers.

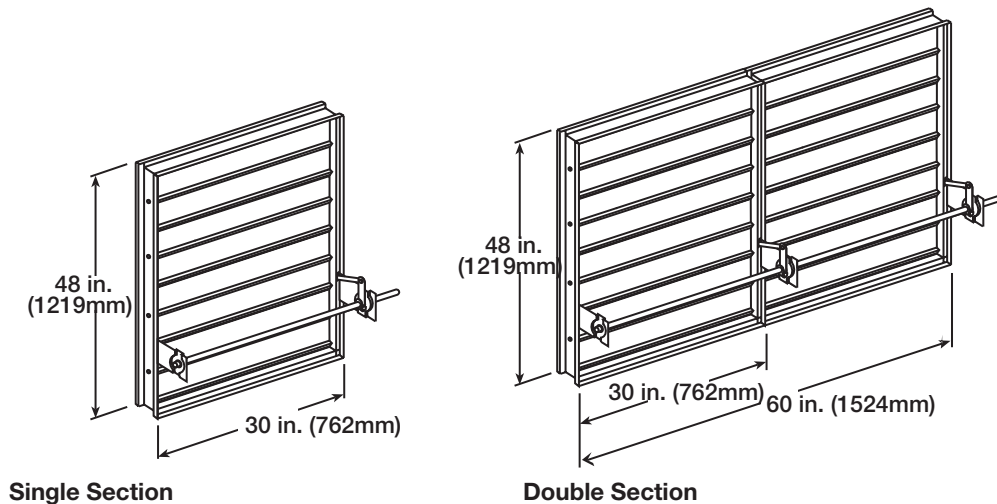

When a fire/smoke damper is being used in conjunction with round or oval ductwork, the FSD-331 can be supplied in a factory sleeve with round or oval transitions on both ends of the sleeve. Dampers should be ordered to the duct dimensions. Drawings below show overall damper size.

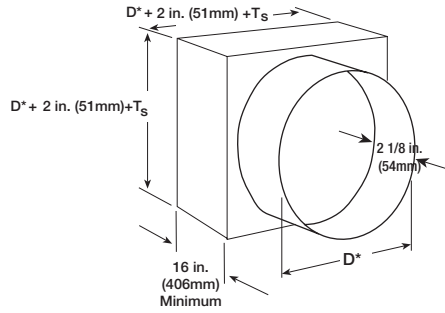

TYPE R

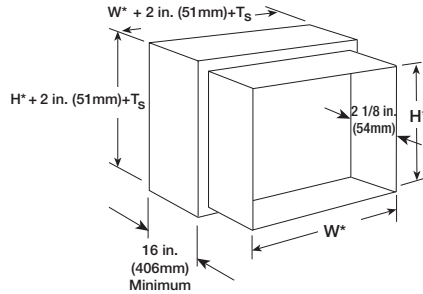

TYPE C

* These dimension are furnished approximately 1/4 in. (6mm) undersize, except round and oval dimensions which are approximately 1/8 in. (3mm) undersize.
 $T_s = (2)(\text{Sleeve Thickness})$

Specifications

Combination fire smoke dampers meeting the following specifications shall be furnished and installed where shown on plans and/or as described in schedules. Dampers shall meet the requirements of NFPA (80, 90A, 92A, 101, and 105) and shall be tested, rated, and labeled in accordance with the latest edition of UL Standards 555 and 555S. Dampers shall have a UL555 fire rating of 3 hours and be of low leakage design qualified to UL555S, Leakage Class I.

Each damper/actuator combination shall have a UL555S elevated temperature rating of 250°F (121°C) minimum and shall be operational and dynamic rated to operate at maximum design air flow at its installed location. Each damper shall be supplied with an appropriate actuator installed by the damper manufacturer at the time of damper fabrication. Damper actuator shall be (specifier select one of the following) electric type for 24 or 230 volt operation.

Damper blades shall be double skin airfoil type and shall have an equivalent thickness of 14 ga. (2mm). Damper frame shall be galvanized steel formed into a structural hat channel shape with reinforced corners. Bearings shall be 304SS type rotating in extruded holes in the damper frame. Blade edge seals shall be silicone rubber designed to inflate and provide a tighter seal against leakage as pressure on either side of the damper increases. Jamb seals shall be stainless steel compression type.

Blades shall be completely symmetrical relative to their axle pivot point, presenting identical resistance to airflow in either direction or pressure on either side of the damper.

Damper must be rated for mounting vertically (with blades running horizontal) and be UL555S rated for leakage and airflow in either direction through the damper. Each damper shall be supplied with a 165°F (74°C) RRL. Testing and ratings to be in accordance with AMCA Standard 500-D.

The basis of design is Greenheck model FSD-331.

