

Application

The ECV-245 offers exceptional protection against wind-driven rain under the most severe conditions. The ECV-245 incorporates vertical blades and is available in a wide array of anodized and painted finishes including custom color matching.

Standard Construction

- Material:** Mill finish 6063-T5 extruded aluminum.
- Frame:** 2" deep × 0.060" thick (51 × 1.5) channel.
- Blades:** 0.060" (1.5) thick horizontal chevron style.
- Screen:** 1/2" × 0.063" (12.7 × 1.6) expanded and flattened aluminum.
- Mullion:** Visible.
- Sill Flashing:** Closed end.
- Minimum Size:** 6" × 12" (152 × 305)
- Maximum Size:** Single section: 60" × 96" (1524 × 2439)
Multiple section: Unlimited

Options

- Factory finish:
 - High Performance 70% Fluoropolymer (Kynar®)
 - Baked Enamel
 - Clear Anodize
 - Integral Color Anodize
 - Prime Coat
- Flange frame:
 - 1 1/2" (38) flange
 - Custom-size flange
 - Stucco flange
 - Glazing frame
- Alternate bird or insect screens.
- Insulated or non-insulated blank-off panels.
- Filter racks.
- Hinged frame.
- Head flashing.
- Installation hardware:
 - Clip angles
 - Continuous angles
- Burglar bars:
 - Shipped loose
 - Shipped mounted
- Frame closure.

Ratings

Free Area: [48" × 48" (1219 × 1219) unit]: 6.6 ft² (0.61 m²)
41.5%

Performance @ Beginning Point of Water Penetration

Free Area Velocity: 1250 fpm (6.35 m/s)
Air Volume Delivered: 8299 cfm (3.92 m³/s)
Pressure Loss: 0.42 in.wg. (104 Pa)

Velocity @ 0.15 in.wg. Pressure Loss: 758 fpm (3.85 m/s)

Design Load: 20 psf

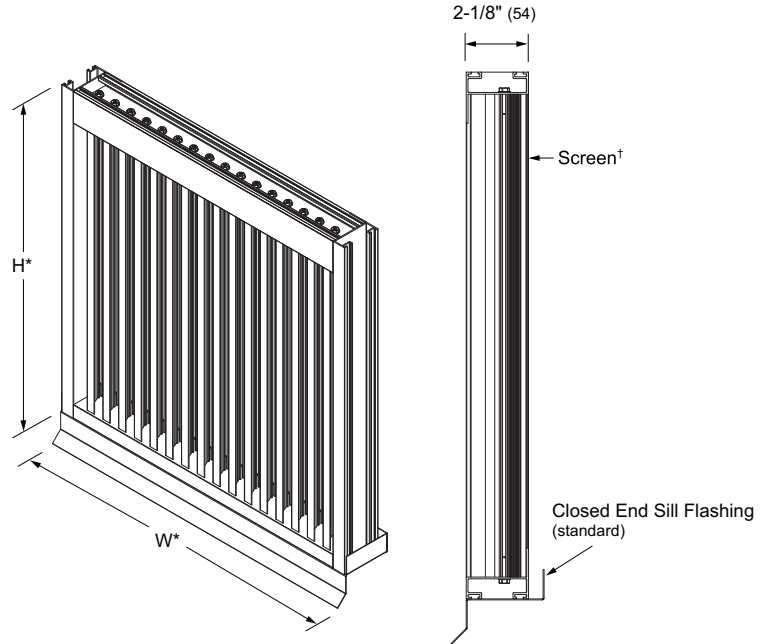

Model **ECV-245**
(standard)

*Louver dimensions furnished approximately 1/2" (13) undersize.

Vertical Section

†Screen adds approximately 3/16" (5) to louver depth.

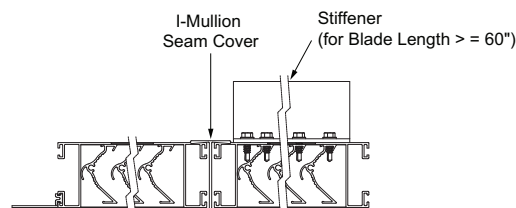

Visible Vertical Mullion
(standard)

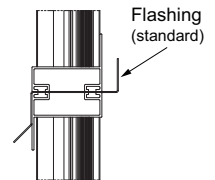

Horizontal Mullion
(standard)

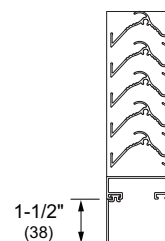

Flange Frame
(optional)

Certified Ratings:

All-Lite Architectural Products certifies that the model ECV-245 shown herein is licensed to bear the AMCA seal. The ratings shown are based on test and procedures performed in accordance with AMCA Publication 511 and comply with the requirements of the AMCA Certified Ratings Program. The AMCA Certified Ratings seal applies to air performance, water penetration and wind-driven rain ratings.



Free Area (ft²)

		Width (Inches)																		
		12	18	24	30	36	42	48	54	60	66	72	78	84	90	96	102	108	114	120
Height (Inches)	12	0.27	0.46	0.64	0.83	1.01	1.20	1.39	1.57	1.76	1.94	2.13	2.32	2.50	2.69	2.87	3.06	3.25	3.43	3.62
	18	0.44	0.74	1.05	1.35	1.65	1.96	2.26	2.57	2.87	3.17	3.48	3.78	4.08	4.39	4.69	4.99	5.30	5.60	5.90
	24	0.61	1.03	1.45	1.87	2.30	2.72	3.14	3.56	3.98	4.40	4.82	5.24	5.66	6.08	6.51	6.93	7.35	7.77	8.19
	30	0.78	1.32	1.86	2.40	2.94	3.47	4.01	4.55	5.09	5.63	6.17	6.71	7.24	7.78	8.32	8.86	9.40	9.94	10.48
	36	0.95	1.61	2.26	2.92	3.58	4.23	4.89	5.54	6.20	6.86	7.51	8.17	8.82	9.48	10.14	10.79	11.45	12.10	12.76
	42	1.12	1.90	2.67	3.44	4.22	4.99	5.76	6.54	7.31	8.08	8.86	9.63	10.41	11.18	11.95	12.73	13.50	14.27	15.05
	48	1.29	2.18	3.08	3.97	4.86	5.75	6.64	7.53	8.42	9.31	10.20	11.09	11.99	12.88	13.77	14.66	15.55	16.44	17.33
	54	1.46	2.47	3.48	4.49	5.50	6.51	7.52	8.52	9.53	10.54	11.55	12.56	13.57	14.57	15.58	16.59	17.60	18.61	19.62
	60	1.63	2.76	3.89	5.01	6.14	7.26	8.39	9.52	10.64	11.77	12.89	14.02	15.15	16.27	17.40	18.52	19.65	20.78	21.90
	66	1.80	3.05	4.29	5.54	6.78	8.02	9.27	10.51	11.75	13.00	14.24	15.48	16.73	17.97	19.21	20.46	21.70	22.95	24.19
	72	1.98	3.34	4.70	6.06	7.42	8.78	10.14	11.50	12.86	14.22	15.59	16.95	18.31	19.67	21.03	22.39	23.75	25.11	26.47
	78	2.15	3.62	5.10	6.58	8.06	9.54	11.02	12.50	13.97	15.45	16.93	18.41	19.89	21.37	22.85	24.32	25.80	27.28	28.76
	84	2.32	3.91	5.51	7.10	8.70	10.30	11.89	13.49	15.08	16.68	18.28	19.87	21.47	23.07	24.66	26.26	27.85	29.45	31.05
90	2.49	4.20	5.91	7.63	9.34	11.05	12.77	14.48	16.20	17.91	19.62	21.34	23.05	24.76	26.48	28.19	29.90	31.62	33.33	
96	2.66	4.49	6.32	8.15	9.98	11.81	13.64	15.47	17.31	19.14	20.97	22.80	24.63	26.46	28.29	30.12	31.95	33.79	35.62	
102	2.83	4.78	6.73	8.67	10.62	12.57	14.52	16.47	18.42	20.37	22.31	24.26	26.21	28.16	30.11	32.06	34.00	35.95	37.90	
108	3.00	5.06	7.13	9.20	11.26	13.33	15.39	17.46	19.53	21.59	23.66	25.73	27.79	29.86	31.92	33.99	36.06	38.12	40.19	
114	3.17	5.35	7.54	9.72	11.90	14.09	16.27	18.45	20.64	22.82	25.00	27.19	29.37	31.56	33.74	35.92	38.11	40.29	42.47	
120	3.34	5.64	7.94	10.24	12.54	14.84	17.15	19.45	21.75	24.05	26.35	28.65	30.95	33.25	35.55	37.86	40.16	42.46	44.76	



Certified Ratings:
All-Lite Architectural Products certifies that the model ECV-245 shown herein is licensed to bear the AMCA seal. The ratings shown are based on test and procedures performed in accordance with AMCA Publication 511 and comply with the requirements of the AMCA Certified Ratings Program. The AMCA Certified Ratings seal applies to air performance, water penetration and wind-driven rain ratings.

Pressure Loss

(Data corrected to standard air density)

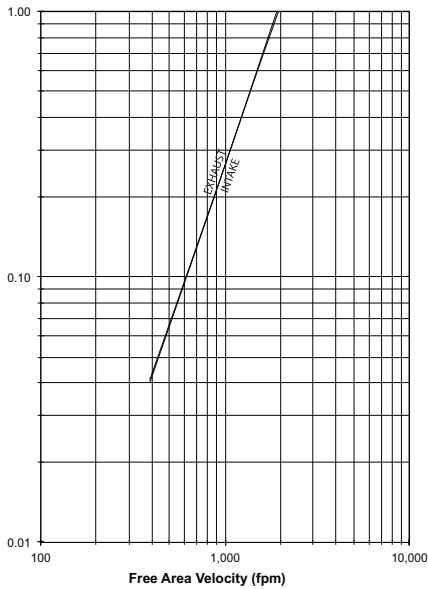

Louver Test Size = 48" x 48" (1219 x 1219)

Pressure loss tested in accordance with Figure 5.5 of AMCA Standard 500-L.

Water Penetration

AMCA defines the beginning point of water penetration as the free area velocity at the intersection of a simple linear regression of test data and the line of 0.01 ounces of water per square foot of free area and is measured through a 48" x 48" louver during a 15 minute period. The AMCA water penetration test provides a method for comparing louver models and designs as to their efficiency in resisting the penetration of rainfall under specific lab conditions. All-Lite Architectural Products recommends that intake louvers are selected with a reasonable margin of safety below the beginning point of water penetration in order to avoid unwanted penetration during severe storm conditions.

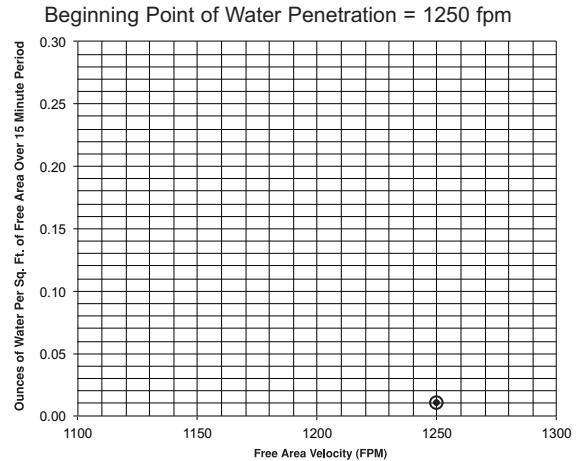

Wind Driven Rain Performance — AMCA 500-L Wind Driven Rain Test

Test louver Core Area₁=10.77 sq. ft.

Wind Velocity	Rainfall	Airflow	Core Velocity	Effectiveness Ratio	Wind Class	Discharge Class
29 mph	3 in/hr	6371 cfm	592 fpm	99.6%	A	3
50 mph	8 in/hr	4300 cfm	399 fpm	99.3%	A	3

Wind Driven Rain ₂ Class	Effectiveness
A	1.000 to 0.99
B	0.989 to 0.95
C	0.949 to 0.80
D	0.799 to 0.00

Discharge Loss ₃ Class	Coefficient
1	0.4 to 1.000
2	0.3 to 0.399
3	0.2 to 0.299
4	0.0 to 0.199

NOTES

1. Core Area is the open area of the louver face (face area less louver frame). 2. Wind Driven Rain Penetration Classes. 3. Discharge Loss Coefficient is calculated by dividing the louvers' actual airflow rate by the theoretical airflow rate for an unobstructed opening. The higher the coefficient the lower the resistance to air flow.

Information is correct at time of printing. However, we reserve the right to make changes without notice.

NOTE: Dimensions in parentheses () are millimeters.