

## Miami-Dade Approved Wind-Driven Rain Louver

### Application and Design

EHH-601DE is a **Florida Product Approved and Miami-Dade Approved** stationary horizontal blade wind driven rain extruded aluminum louver designed to protect air intake and exhaust openings in building exterior walls. EHH-601DE is tested in accordance with AMCA 500-L Air Performance, Water Penetration and Wind Driven Rain. In addition, louvers shall pass AMCA 540 Test Method for Louvers Impacted by Wind Borne Debris (Basic Protection, Missile Level D and Enhanced Protection, Missile Level E). **EHH-601DE is licensed to bear the AMCA seal allowing design professionals to select and apply with confidence.** EHH-601DE is tested and approved per the following Florida test protocols: TAS 201 (Large Missile Impact), TAS 202 (Uniform Static Air Pressure) and TAS 203 (Cyclic Wind Loading). Per Miami-Dade EHH-601DE may be installed in locations where the space behind the louver is designed to accept water penetration and houses water resistant/water proof equipment, components or supplies.

### Standard Construction

- Frame** . . . . . Heavy gauge extruded aluminum, 6 in. x 0.081 in. nominal wall thickness, front 1.5 in. flange (optional on channel frame installation)
- Blades** . . . . . Horizontal rain resistant style, heavy gauge extruded aluminum, 0.081 in. nominal wall thickness, positioned on approximately 2 in. blade spacing
- Construction** . . . . . Mechanically Fastened
- Birdscreen** . . . . . 3/4 in. x 0.051 in. flattened expanded aluminum in removable frame, inside mount (rear), mill finish only
- Finish** . . . . . Mill
- Sill Pan** . . . . . 0.063 formed aluminum

- Minimum Rough Opening Size**
- Opening Size** . . . . . 12 in. W x 7 in. H
- Maximum Rough Opening Size**
- Channel Frame** . . . . . 48.75 in. W x 48.50 in. H
- Maximum Rough Opening Size**
- Flange/Sleeve** . . . . . 48.5 in. W x 48.50 in. H

### Options (at additional cost)

- Factory attached VCD-40 control damper
- A variety of bird and insect screens
- Flange Frame (Channel Frame Installation)
- Mounting Sleeve
- Blank-off panel
- Filter rack
- Security bars
- A variety of architectural finishes including:
  - Clear anodize
  - Integral color anodize
  - Baked enamel
  - Kynar

Channel Frame Installation (default)

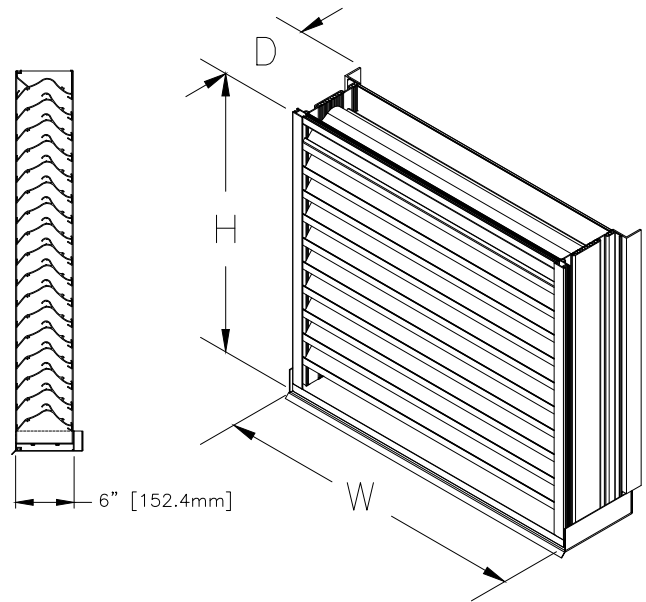

Flange/Sleeve Installation (optional)

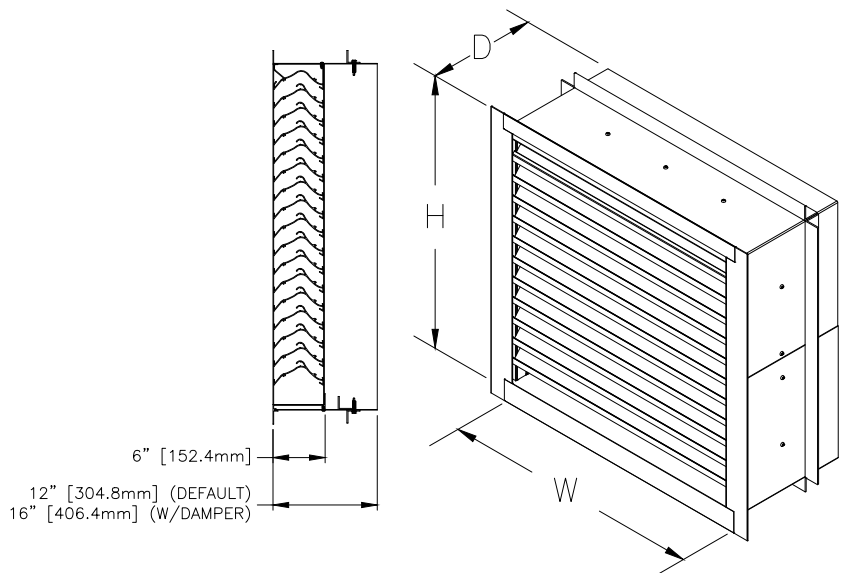

# PERFORMANCE DATA

# EHH-601DE

Florida Product Approval No: **PENDING**  
 Miami-Dade NOA No.: **15-1013.12 EXP. PENDING**  
 Maximum Wind-load: **+/-150 PSF**

## Wind-Driven Rain Performance

| 75 mm/h (3 in./hr) Rainfall & 13 m/s (29 mph) Wind Velocity |       |                               |       |                   |           | 202 mm/h (8 in./hr) Rainfall & 22 m/s (50 mph) Wind Velocity |       |                               |       |                   |           |
|---|-------|-------------------------------|-------|-------------------|-----------|--|-------|-------------------------------|-------|-------------------|-----------|
| Free Area Velocity  |       | Ventilation Air Core Velocity |       | Water Penetration |           | Free Area Velocity   |       | Ventilation Air Core Velocity |       | Water Penetration |           |
| (fpm)   | (m/s) | (fpm)                         | (m/s) | Class             | Effective | (fpm)  | (m/s) | (fpm)                         | (m/s) | Class             | Effective |
| 0   | 0     | 0                             | 0     |                   |           | 0  | 0     | 0                             | 0     |                   |           |
| 179   | 0.9   | 98                            | 0.5   |                   |           | 179  | 0.9   | 98                            | 1.0   |                   |           |
| 359   | 1.8   | 197                           | 1.0   |                   |           | 359  | 1.8   | 197                           | 1.5   |                   |           |
| 538   | 2.7   | 295                           | 1.5   |                   |           | 538  | 2.7   | 295                           | 2.0   |                   |           |
| 718   | 3.6   | 394                           | 2.0   |                   |           | 718  | 3.6   | 394                           | 2.5   |                   |           |
| 897   | 4.6   | 492                           | 2.5   |                   |           | 864  | 4.4   | 474                           | 2.4   | 99.5              | A         |
| 1077  | 5.5   | 591                           | 3.0   |                   |           | 1033   | 5.2   | 567                           | 2.9   | 99.6              | A         |
| 1217  | 6.2   | 668                           | 3.4   | A                 | 100.0     | 1232   | 6.3   | 676                           | 3.4   | 99.2              | A         |
| 1391  | 7.1   | 763                           | 3.9   | A                 | 99.8      | 1394   | 7.1   | 765                           | 3.9   | 98.5              | B         |
| 1527  | 7.8   | 838                           | 4.3   | B                 | 98.1      | 1567   | 8.0   | 860                           | 4.4   | 95.6              | B         |
| 1801  | 9.1   | 988                           | 5.0   | B                 | 95.4      | 1744   | 8.9   | 957                           | 4.9   | 88.7              | C         |

Discharge Loss Coefficient Class (Intake) = 2

Weather louvers shall be classified by their ability to reject simulated rain. The table shows different classifications based on the maximum simulated rain penetration per square meter (square feet) of louver. Water penetration rating at a given louver face velocity is determined by the water penetration while the louver is subjected to a selected simulated rainfall rate and wind velocity.

## Airflow Resistance (Standard Air - .075 lb/ft<sup>3</sup>)

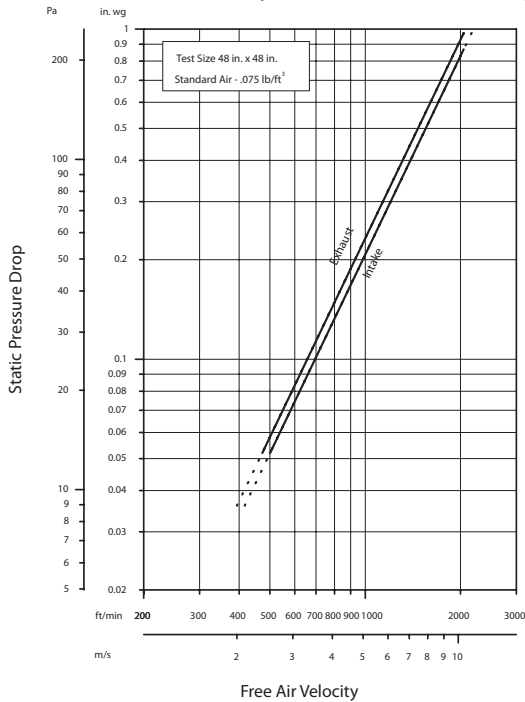

Model EHH-601DE resistance to airflow (pressure drop) varies depending on louver application (air intake or air exhaust). Free area velocities (shown) are higher than average velocity through the overall louver size. See louver selection information. (Test Figure 5.5-6.5)



**AMCA**  
WORLDWIDE  
CERTIFIED  
RATINGS

**WATER PENETRATION**  
**AIR PERFORMANCE**  
**WIND DRIVEN RAIN**

**AIR MOVEMENT AND CONTROL ASSOCIATION INTERNATIONAL, INC.**

Greenheck Fan Corporation certifies that the EHH-601DE (*channel and flange/sleeve frame*) louvers shown herein are licensed to bear the AMCA Seal. The ratings shown are based on tests and procedures performed in accordance with AMCA Publication 511 and comply with the requirements of the AMCA Certified Ratings Program. The AMCA Certified Ratings Seal applies to air performance, water penetration, and wind-driven rain ratings.\*

**AMCA**  
INTERNATIONAL

**LISTED**

**IMPACT RESISTANT LOUVER**  
*Enhanced Protection*

\* See www.AMCA.org for all certified or listed products

This label does not signify AMCA airflow performance certification.

Greenheck Fan Corporation certifies that the EHH-601DE (*channel and flange/sleeve frame*) louvers shown herein are approved to bear the AMCA Listing Label. The Ratings shown are based on tests and procedures performed in accordance with AMCA Publications and comply with the requirements of the AMCA Listing Label Program. The AMCA Listing Label applies to Wind Borne Debris Impact Resistant louvers.

| Discharge Loss Coefficient Classifications |                            | Wind-driven Rain Penetration Classes |               |
|--|----------------------------|--------------------------------------|---------------|
| Class                                      | Discharge Loss Coefficient | Class                                | Effectiveness |
| 1  | 0.4 and Above              | A                                    | 1 to 0.99     |
| 2  | 0.3 to 0.399               | B                                    | 0.989 to 0.95 |
| 3  | 0.2 to 0.299               | C                                    | 0.949 to 0.80 |
| 4  | 0.199 and Below            | D                                    | Below 0.80    |

## Water Penetration

Test Size 48 in. x 48 in. Test Duration of 15 min

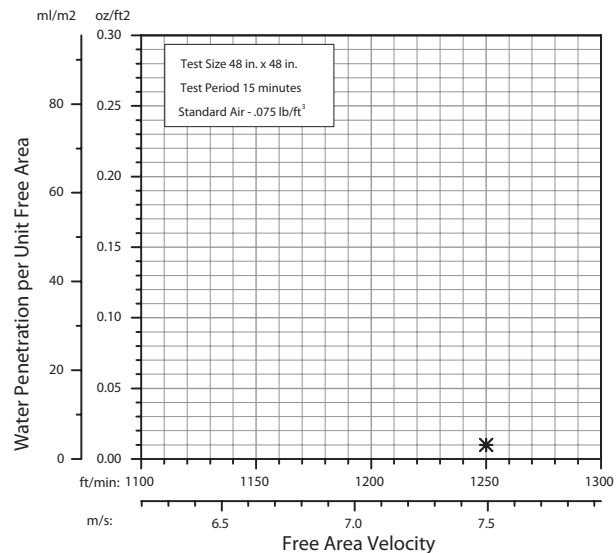

The AMCA Water Penetration Test provides a method for comparing various louver models and designs as to their efficiency in resisting the penetration of rainfall under specific laboratory test conditions. The beginning point of water penetration is defined as that velocity where the water penetration curve projects through 0.01 oz. of water (penetration) per sq. ft. of louver free area. **\*The beginning point of water penetration for Model EHH-601DE is above 1250 fpm free area velocity.** These performance ratings do not guarantee a louver to be weather-proof or stormproof and should be used in combination with other factors including good engineering judgement in selecting louvers.

*Note: AMCA licensed performance data shown herein pertains only to the louver and does not include effects of the factory attached VCD-40 damper.*

# PERFORMANCE DATA

# EHH-601DE

Florida Product Approval No: *PENDING*  
Miami-Dade NOA No.: 15-1013.12 EXP. *PENDING*  
Maximum Wind-load: +/-150 PSF

## Free Area Chart (sq. ft.)

| Louver Height Inches | Louver Width in Inches |      |      |      |      |      |             |
|----------------------|------------------------|------|------|------|------|------|-------------|
|                      | 12                     | 18   | 24   | 30   | 36   | 42   | <b>48</b>   |
| 7                    | 0.07                   | 0.12 | 0.17 | 0.21 | 0.26 | 0.31 | 0.36        |
| 12                   | 0.23                   | 0.38 | 0.53 | 0.67 | 0.82 | 0.97 | 1.12        |
| 18                   | 0.47                   | 0.77 | 1.07 | 1.36 | 1.66 | 1.96 | 2.26        |
| 24                   | 0.71                   | 1.16 | 1.61 | 2.05 | 2.50 | 2.95 | 3.40        |
| 30                   | 0.95                   | 1.55 | 2.15 | 2.74 | 3.34 | 3.94 | 4.54        |
| 36                   | 1.11                   | 1.81 | 2.50 | 3.20 | 3.90 | 4.60 | 5.30        |
| 42                   | 1.35                   | 2.19 | 3.04 | 3.89 | 4.74 | 5.59 | 6.44        |
| <b>48</b>            | 1.58                   | 2.58 | 3.58 | 4.58 | 5.58 | 6.58 | <b>7.58</b> |

## Core Area Chart (sq. ft.)

| Louver Height Inches | Louver Width in Inches |      |      |      |       |       |              |
|----------------------|------------------------|------|------|------|-------|-------|--------------|
|                      | 12                     | 18   | 24   | 30   | 36    | 42    | <b>48</b>    |
| 7                    | 0.20                   | 0.32 | 0.45 | 0.57 | 0.70  | 0.82  | 0.95         |
| 12                   | 0.53                   | 0.86 | 1.19 | 1.53 | 1.86  | 2.19  | 2.53         |
| 18                   | 0.92                   | 1.51 | 2.09 | 2.67 | 3.26  | 3.84  | 4.42         |
| 24                   | 1.32                   | 2.15 | 2.99 | 3.82 | 4.65  | 5.49  | 6.32         |
| 30                   | 1.72                   | 2.80 | 3.88 | 4.97 | 6.05  | 7.13  | 8.22         |
| 36                   | 2.11                   | 3.44 | 4.78 | 6.11 | 7.44  | 8.78  | 10.11        |
| 42                   | 2.51                   | 4.09 | 5.67 | 7.26 | 8.84  | 10.42 | 12.01        |
| <b>48</b>            | 2.90                   | 4.74 | 6.57 | 8.40 | 10.24 | 12.07 | <b>13.90</b> |

## Building Condition/Substrate Limitations

### Channel Installation

- All steel substrate should be min. 16 Ga. FY= 33 KSI
- All concrete substrate shall be min. 2000 PSI
- All concrete masonry shall be ASTM C90, Type II, grout-filled
- All wood substrate shall be G= 0.42 density or better
- All aluminum substrate shall be min 0.125 in. thick FY=16 KSI

### Flange/Sleeve Installation

- Any substrate acceptable that is capable of withstanding imposed loads.

# OPTION DRAWINGS

# EHH-601DE

Florida Product Approval No: *PENDING*  
 Miami-Dade NOA No.: 15-1013.12 EXP. *PENDING*  
 Maximum Wind-load: +/-150 PSF

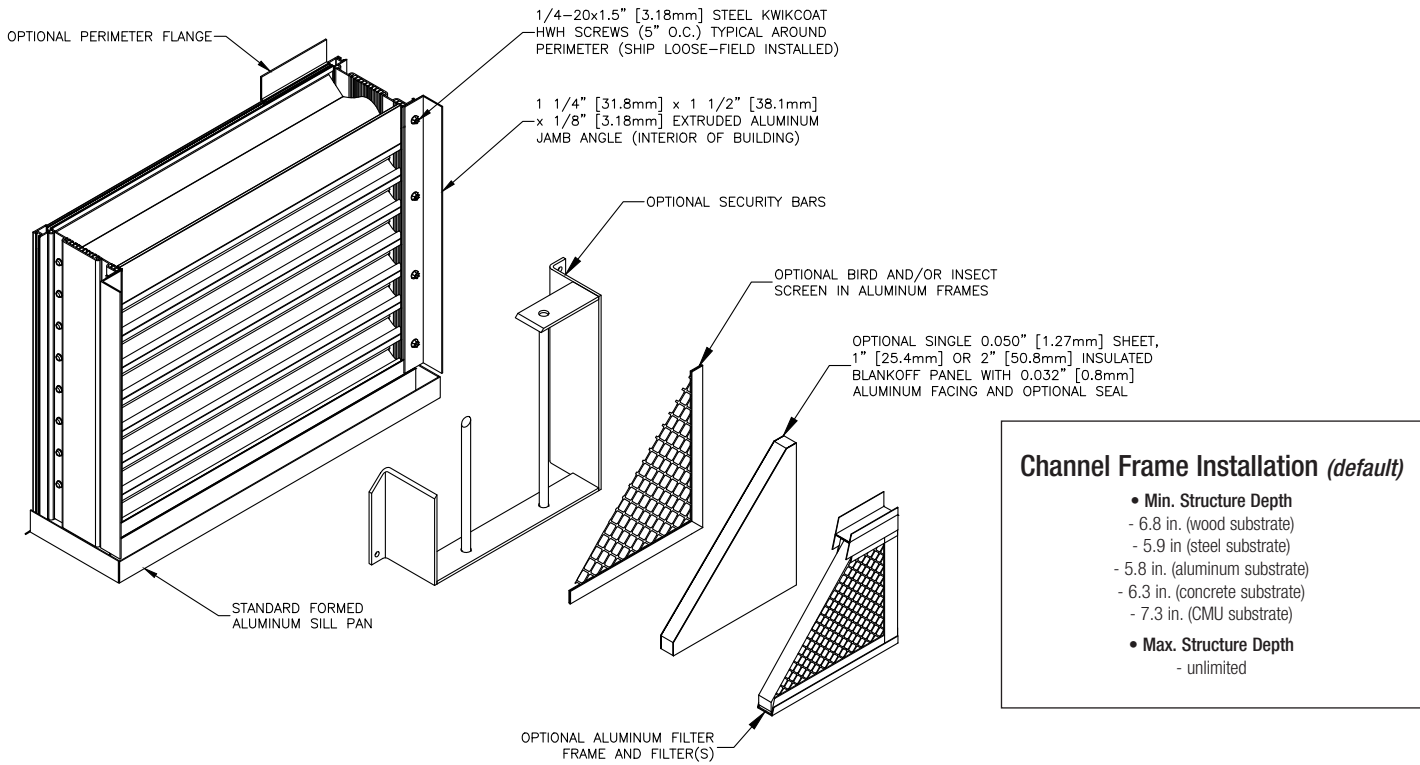

**Channel Frame Installation (default)**

- **Min. Structure Depth**
  - 6.8 in. (wood substrate)
  - 5.9 in (steel substrate)
  - 5.8 in. (aluminum substrate)
  - 6.3 in. (concrete substrate)
  - 7.3 in. (CMU substrate)
- **Max. Structure Depth**
  - unlimited

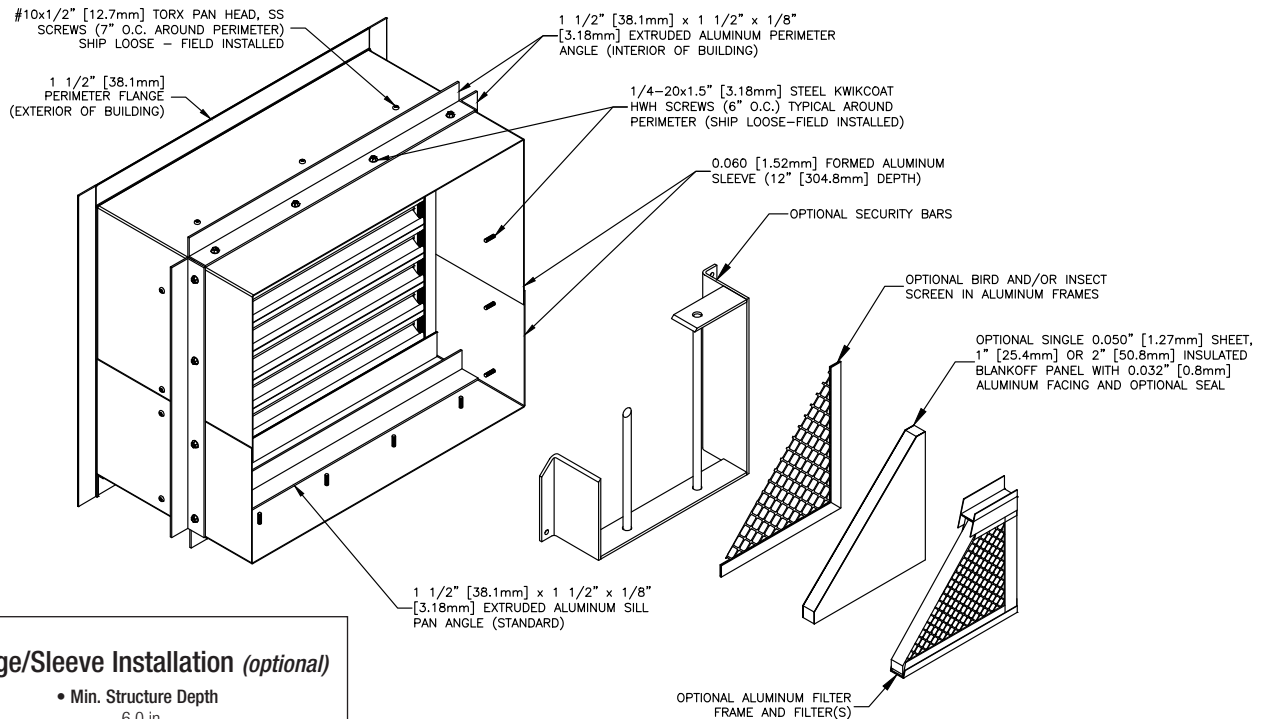

**Flange/Sleeve Installation (optional)**

- **Min. Structure Depth**
  - 6.0 in.
- **Max. Structure Depth**
  - 10.5 in. (12 in. sleeve)
  - 14.5 in. (16 in. sleeve)

# OPTION DRAWINGS

# EHH-601DE with VCD-40

Florida Product Approval No: *PENDING*  
 Miami-Dade NOA No.: 15-1013.12 EXP. *PENDING*  
 Maximum Wind-load: +/-150 PSF

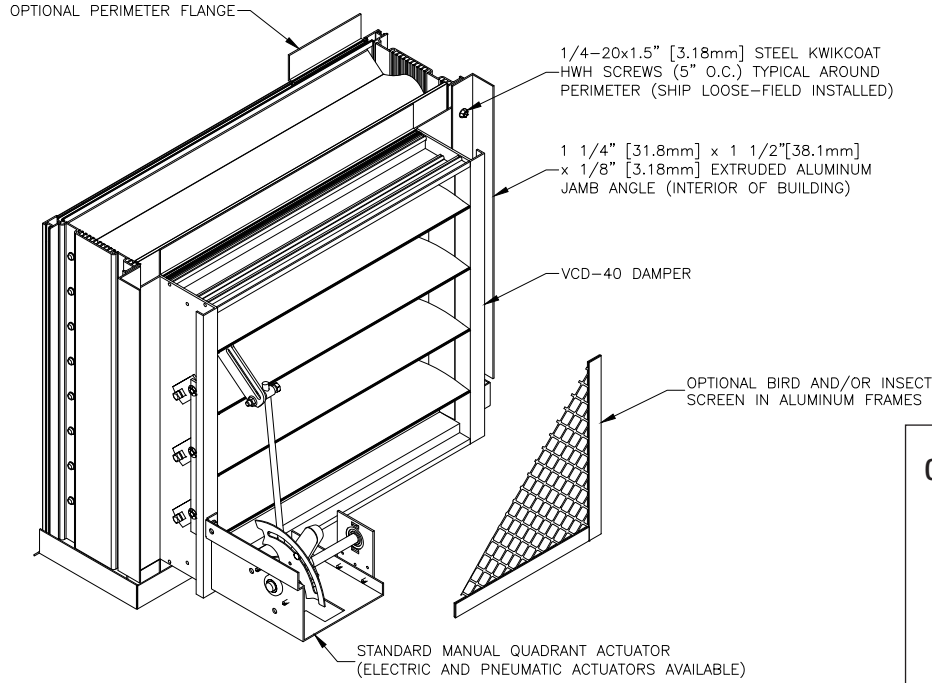

**Channel Frame Installation (default)**

- **Min. Structure Depth**
  - 6.8 in. (wood substrate)
  - 5.9 in (steel substrate)
  - 5.8 in. (aluminum substrate)
  - 6.3 in. (concrete substrate)
  - 7.3 in. (CMU substrate)
- **Max. Structure Depth**
  - unlimited

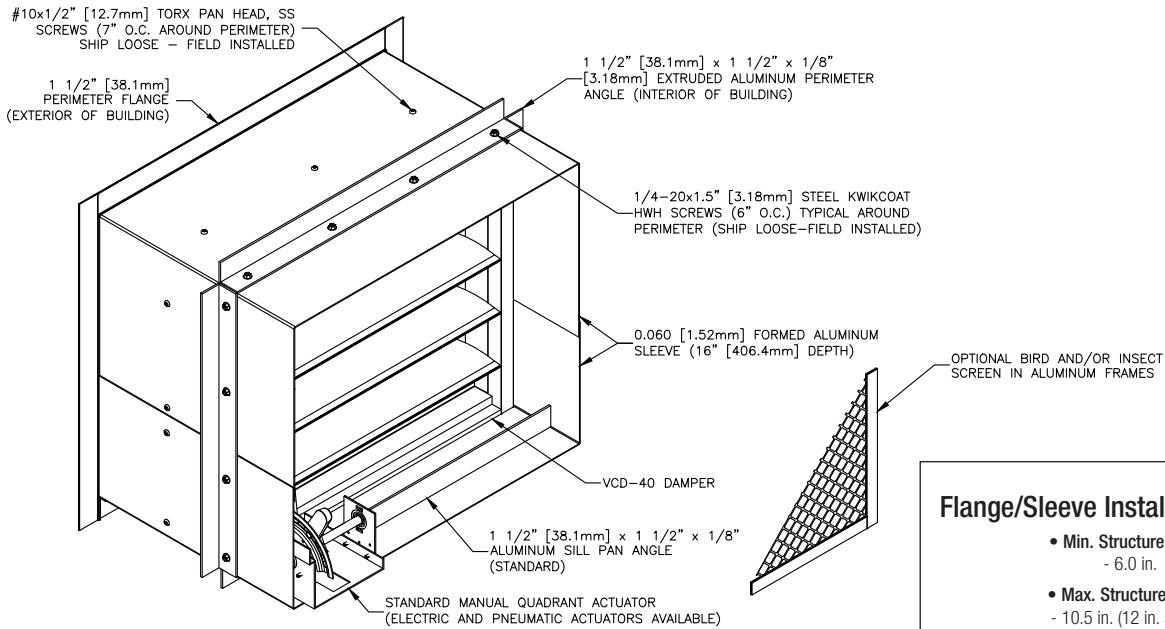

**Flange/Sleeve Installation (optional)**

- **Min. Structure Depth**
  - 6.0 in.
- **Max. Structure Depth**
  - 10.5 in. (12 in. sleeve)
  - 14.5 in. (16 in. sleeve)

*For additional information reference the Installation, Operation and Maintenance (IOM) manuals.*



EHH-601DE  
 November 2015 Rev. 1  
 Copyright © 2015 Greenheck Fan Corporation