

Sound Attenuators Catalogue

DVAC

DUCT VENTILATION AIR CONDITIONING Co. (W.L.L.)

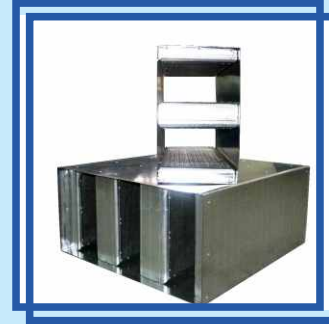

TYPES: RSA, CASA & CBSA
RECTANGULAR AND CIRCULAR

LICENSED TO BEAR THE AMCA SEAL

FOR USE IN AIR DUCT SYSTEM

Made in Qatar



DUCT VENTILATION AIR CONDITIONING Co. (W.L.L.)

Table Of Contents

Sound Attenuators / General

	Page
Introduction	3
Acoustic Design	4
Definitions	5
Room Side Calculation	6---10
Room Side Calculation Sheet	11

Rectangular Sound Attenuator

Test Method	12
Materials & Construction	13
Installation Guidelines	14-15

Sound Attenuator Model RSA 3'	16
Sound Attenuator Model RSA 4'	17
Sound Attenuator Model RSA 5'	18
Sound Attenuator Model RSA 6'	19
Sound Attenuator Model RSA 7'	20
Sound Attenuator Model RSA 8'	21

Airflow Performance - Type RSA	22
Weights - Type RSA	23

Circular Sound Attenuator

Type CASA & CBSA - Materials & Thickness	24
Type CASA & CBSA - Connectors	25

Calculation & Selection

Software Calculation	26-27
Selection Data.....	28-29
Instructions.....	30
Remarks	31

INTRODUCTION

DVAC-Duct Ventilation Air Conditioning Co. (W.L.L.) is a Leading Manufacturer Of Certified Sound Attenuators. This has been achieved through the professionalism of Expert & Senior Mechanical Engineers.

DVAC Sound Attenuators are designed to achieve the required performances As set out in the **ASTM Standards E477-06a** for Prefabricated Attenuators.

DVAC-Duct Ventilation Air Conditioning Co. (W.L.L.) Certifies that the Sound Attenuators shown herein are licensed to bear the **AMCA Seal**.

The Ratings shown herein are based on tests and procedures performed in accordance wWith **AMCA PUBLICATION 1011** and comply with the requirements of the **AMCA** Certified Ratings Program.

AMCA Certified Ratings Seal applies to Dynamic Insertion Loss, Airflow Generated Noise and Pressure Drop.

Models RSA3', RSA4', RSA5', RSA6', RSA7' & RSA8' are certified and their Certified Performance is mentioned on pages 16---21.



NOISE CONTROL - PRINCIPLES

There are Three Distinct Stages to the Noise Control Process:

- 1- Source
- 2- Transmission
- 3- Reception

It is correct, though impracticable, to propose that noise can be controlled at any of these stages. In the case of the fan, for example, the manufacturer has already produced a quiet design within the constraints of commercial prudence and the office worker is unlikely to take too kindly to a suggestion that the wearing of ear protectors is a satisfactory means of combating the air-conditioning noise! This leaves us with having to control the noise during the transmission.

Noise control Engineers have two weapons with which to combat noise - mass and absorption - usually applied in a combination. The term mass, for example, meaning the plantroom built of heavyweight materials and absorption being the splitter attenuators strategically located to acoustically seal the ducts where they penetrate the mass barrier.

GOOD ACOUSTIC DESIGN

It is commonly believed that the ventilation Engineer having selected the quietest fan for the required duty need play no further role in noise control except perhaps to call in the noise control specialists at a later date.

Frequently when this happens the Acoustic Engineer demands vast amount of plantroom space for the attenuators or suggests dramatic changes in design. Both clearly can cost considerable time and money. The obvious approach, even at the very early stages is to take the acoustic requirements into consideration.

Certainly the Ventilation Engineer should seek advice regarding the following:

1. What noise criteria need to be achieved in the ventilated areas?
2. Is the criteria thus established likely to be achievable without the applications of noise control techniques?
3. If noise control is required, ductwork design must leave sufficient space, preferably in straight duct runs.
Plantrooms and plant should be located away from noise sensitive areas. Are plantroom walls substantial enough?
Is sufficient pressure development available on the fans for attenuators?
4. Are neighbors likely to be affected by noise? What, if any, atmospheric noise control is required?
5. If plant has to be located close to noise sensitive areas or in false ceiling spaces what additional care should be taken in the initial selection of noisy items?
6. Is the client aware that space restrictions imposed by him could result in noise problems; has the client, in applying for planning permission had any requirements related to noise imposed upon him?

During the design stage, the common pitfalls should be avoided, these include:

1. Right angle bends and take-offs.
2. Ineffective expansions and contractions.
3. Incorrectly located dampers, heater batteries and cooling coils.
4. Fans located above lightweight ceilings or immediately above or below the most sensitive rooms.

In addition some acoustic assessment should be carried out in order to ensure that realistic space is allowed for attenuators and that they are positioned effectively.

DEFINITIONS

The following terms are commonly used in the field of acoustics and an understanding of their practical (rather than academic) meaning and import might be of use to the Ventilation Engineer.

SOUND POWER LEVEL (SWL)

A theoretical assessment of sound produced at source calculated from the measured Sound Pressure Levels at known distances from the source under known acoustic conditions.

A level which depends only on the source and is independent of the environment or location. The Sound Power Level of a fan is therefore very useful information since any level quoted can be compared directly with data from any other manufacturer.

SOUND PRESSURE LEVEL (SPL)

A measured Sound Level which is an indication only of the noise produced at source since environmental factors such as reverberation and distance from the source have affected the measurement. The Sound Pressure Level of a fan is not very useful since environmental factors apparent when the unit was measured may or may not be present in the actual location of the plant.

DECIBEL (dB)

Commonly, the unit used to measure sound. It is used to quantify both Sound Pressure Level and Sound Power Level.

CRITERIA

Noise Levels which are subjectively or objectively acceptable in a given environment. The most commonly used Criteria are Noise Criteria Curves (**NC Levels**), Noise Rating Curves (**NR Levels**) and dB (A).

DUCTBORN NOISE

Noise which is transmitted along ductworks, both upstream and downstream of a fan.

FLANKING NOISE (BREAKOUT)

Noise transmitted through a barrier, often a fan casing or ductwork. Any indirect noise path which tends to devalue noise control measures used to reduce transmission along the more obvious paths.

NOISE OUTLET

Usually a grille or a diffuser. Any opening acting as a terminal element on either an extract or supply system.

DIRECT SPL

Noise which is transmitted directly from a source (i.e. a grille or diffuser) without reflection.

REVERBERANT SPL

Noise which is transmitted by reflection of room surfaces.

REVERBERATION TIME

A measurement of the acoustic "reflectiveness" of a room.

INSERTION LOSS

A measure of the noise reduction capability of an attenuator (sometimes of a partition) so named after the method of testing where a section of ductwork is replaced by an attenuator between two test rooms. One room contains the noise source and the other the sound level measuring equipment. The difference in recorded noise level is said to be the insertion loss due to the insertion of the attenuator in the system.

REGENERATED NOISE

Noise in addition to that produced by the fan, caused by air passing over fixed duct elements such as blades on grilles, dampers, air turns, splitters in attenuators, etc.. is not normally a problem on low velocity systems and is not dealt within this booklet.

OCTAVE BANDS

Subdivisions of the Frequency range each identified by its mid (or centre) frequency. By international agreements these comprise 63, 125, 250, 500, 1k, 4k, and 8k Hz.

FREQUENCY (Hz)

The pitch of sound; The number of sound pressure waves arriving at a fixed point per second.

A-WEIGHTED SOUND LEVEL

The Sound Level measured using the A-weighting network of a Sound Level meter. For broadband sounds, the A-weighted sound level indicates approximate relative loudness.

PART 1

A- How to find the In-duct SWL of the fan:

Using the fan manufacturer's catalogue information obtain the In-duct Sound Power Level at the mid-frequency Octave Bands of interest, or calculate the approximate In-duct Sound Power Level from Table 1.

In both cases the approximate duty of the fan needs to be known.

These figures are inserted in line "a".

Some manufacturers present noise data as a Sound Pressure Level which needs to be converted by applying the relevant correction factor.

PART 2

Investigate the duct system between the fan and the critical noise outlet

The "critical" noise outlet in the duct system is usually the noise outlet closest to the fan using the following information assess The total duct attenuation:

B- Straight unlined ducts provide a degree of attenuation.

This is frequency dependent and varies with the minimum duct dimension and duct length.

Approximate attenuation per meter run is shown in Table 2.

To avoid noise breakout problems the duct attenuation taken should be limited to approximately 15dB. Bends provide attenuation as shown in Tables 3a and 3b. Duct and bend attenuation figures should be entered against line "b".

(Refer to Calculation Sheet Page 11)

Table 1: In-duct SWL of the Fan

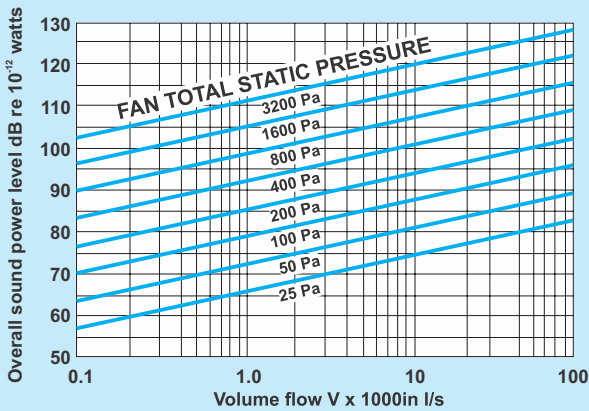

Spectrum Correction

Frequency Hz	63	125	250	500	1k	2k	4k	8k
Forward curved centrifugal	-2	-7	-12	-17	-22	-27	-32	-37
Backward curved centrifugal	-7	-8	-7	-12	-17	-22	-27	-32
Axial	-5	-5	-6	-7	-8	-11	-14	-17

Table 2: The attenuation of straight unlined rectangular ducts - dB per meter

Minimum Duct Dimensions S in mm	Octave centre frequency, fm in Hz							
	63	125	250	500	1k	2k	4k	8k
0-200	0.6	0.6	0.45	0.3	0.3	0.3	0.3	0.3
201-400	0.6	0.6	0.45	0.3	0.2	0.2	0.2	0.2
401-800	0.6	0.6	0.3	0.15	0.15	0.15	0.15	0.15
801-2000	0.3	0.15	0.15	0.1	0.06	0.06	0.03	0.06

Table 3a: The attenuation of mitred bends with short chord turning vanes or no turning vanes.

Dimensions S in mm	Octave centre frequency, fm in Hz							
	63	125	250	500	1k	2k	4k	8k
0-200	0	0	0	0	6	8	4	3
201-400	0	0	0	6	8	4	3	3
401-800	0	0	6	8	4	3	3	3
801-2000	0	6	8	4	3	3	3	3

Table 3b: The attenuation of mitred bends with long chord turning vanes or radiussed bends. (Circular or Rectangular)

Dimensions S in mm	Octave centre frequency, fm in Hz							
	63	125	250	500	1k	2k	4k	8k
0-250	0	0	0	0	1	2	3	3
251-500	0	0	0	1	2	3	3	3
501-1000	0	0	1	2	3	3	3	3
1001-2000	0	1	2	3	3	3	3	3

PART 3

- C- At low frequencies some of the sound power on reaching the critical noise outlet is reflected back along the duct. The degree of attenuation due to this phenomenon is dependent on frequency and the total area of the outlet. The attenuation from Table 4 is inserted in line "c".
- D- The total duct attenuation is obtained from lines "b" & "c" and is inserted in line "d".
- E- The Sound Power Level leaving the critical outlet is obtained from: $e=a-d$

To estimate the **Direct Sound Pressure Level**.

- F- Calculate the percentage of the total sound leaving the critical noise outlet. This is approximately equal to the percentage of the fan air volume which passes through the critical outlet. Table 5 gives the factors to be inserted in line "f".
- G- Estimate the distance between the nearest listening position and the critical outlet and, using Table 6, insert the distance factors in line "g". Unless the specification states otherwise, the commonly applied distance is 1.5 meters.

Calculate the Room Effect

In a room the sound pressure waves will reach the listener along Two paths:

1. Directly, reducing as the (distance) 2 from the noise source, known as the **Direct Sound Pressure Level**.
2. By multiple reflections off the room surfaces and room contents, which will depend upon the size of the room and the reverberation time, known as the **Reverberant Sound Pressure Level**.

(Refer to Calculation Sheet Page 11)

Table 4: Outlet reflection, dB

Outlet area cm ²	Octave Centre Frequency, fm in Hz				
	63	125	250	500	1k
100	20	15	10	6	6
	19	14	9	5	6
	18	13	8	4	6
	17	12	7	3	
	16	11	6	2	6
	15	10	5	1	
14	9	4			
13	8	3			
12	7				
11	6	2			
10	5				
500	9	4	1		
	8	0			
	7		0		
	6				
1000	5	0			
	4				
	3	0			
2					
5000	1	0			
	0				
10000	0	0			
	-1				

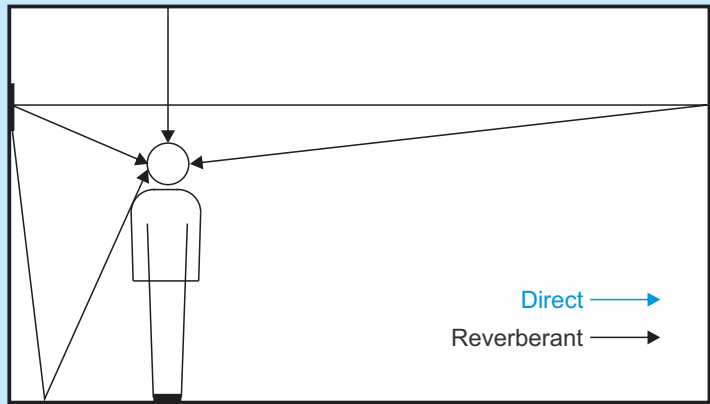

Table 5: Percentage of total sound factors, dB

-20	-19	-18	-17	-16	-15	-14	-13	-12	-11	-10	-9	-8	-7	-6	-5	-4	-3	-2	-1	0	
1	2	3	4	5	10	20	50	100													

Metres

Table 6: Distance Factors, dB

-10	-11	-12	-13	-14	-15	-16	-17	-18	-19	-20	-21	-22	-23	-24	-25	-26	-27	-28	-29	-30	
1	1.5	2	3	4	5	6	7	8	9												

Metres

H- By examining Table 7, select the location type (A or B or C) which is closest to matching the position of the critical outlet in the room using the charts for the chosen location, type and outlet area, insert the factors obtained in line "h".

Note: These figures are positive and to avoid possible confusion the positive sign should also be inserted in line "h".

I- The factors tabulated at each Octave Band in lines "f", "g" & "h" are now added together in line "i", to give the total Direct factors, remembering that the factors in line "h" are positive.

J- The Direct Sound Pressure Level in the room is equal to the sum of the Sound Power Level leaving the Critical Outlet in line "e" and the Total Direct Factors shown in line "i".

To estimate the **Reverberant Sound Pressure Level**.

K- For the fan system in question, calculate the percentage of the sound emerging from all the noise outlets in the room served by the fan.

This approximates to the percentage of the fan air volume serving the room under investigation.

Using Table 8 insert the factor in line "k".

(Refer to Calculation Sheet Page 11)

Table 7: Directivity factors, dB

Type A	Junction of three room surfaces = +9 throughout

Type B	Junction of two room surfaces	Octave Centre frequency in Hz	Type B	Centre of one room surface							
Outlet area, cm ²			Outlet area, cm ²								
10	100	1000	10000	10	100	1000	10000	100000			
+6		+7	+8	63							
+6		+7	+8	125							
+6		+7	+8	+9	250						
+6		+7	+8	+9	+3	+4	+5	+6	+7	+8	+9
+7		+8	+9	1k							
+7		+8	+9	2k							
+7		+8	+9	4k							
+8		+9	8k								

Table 8: Percentage of total sound-factors, dB

-20	-19	-18	-17	-16	-15	-14	-13	-12	-11	-10	-9	-8	-7	-6	-5	-4	-3	-2	-1	0
1	2	3	4	5	10	20	50	100												
Percentage																				

LM- The amount of reflection or absorption of the sound emerging from the noise outlets, depends upon the volume and the reverberation time (which is a function of the amount of absorption) of the room. Tables 9 and 10 give factors related to these which are inserted in lines "l" and "m" respectively.

N- The factors tabulated at each Octave Band in lines "k", "l" & "m" are now added together in line "n", to give the Total Reverberant Factor.

O- The Reverberant Sound Pressure Level (line "o") in the room is equal to the sum of the Sound Pressure Level leaving the Critical Outlet (line "e") and the Total Reverberant Factors (line "n")

P- To arrive at the Combined Sound Pressure Level, it is necessary to logarithmically sum the Reverberant Sound Pressure Level and the Direct Sound Pressure Level. This can be simplified by using Table 11. The combined Pressure level can then be entered in line "p".

(Refer to Calculation Sheet Page 11)

Table 9: Room Volume factors, dB

+10	+9	+8	+7	+6	+5	+4	+3	+2	+1	0	-1	-2	-3	-4	-5	-6	-7	-8	-9	-10	-11	-12	-13	-14	-15	-16	-17	-18	-19	-20	-21	-22	-23	-24	-25	-25	-27	-28	
3	5	10	20	50	100	200	500	1000	2000	5000	10000																												
Volume m ²																																							

Table 10: Reverberation Time factors, dB

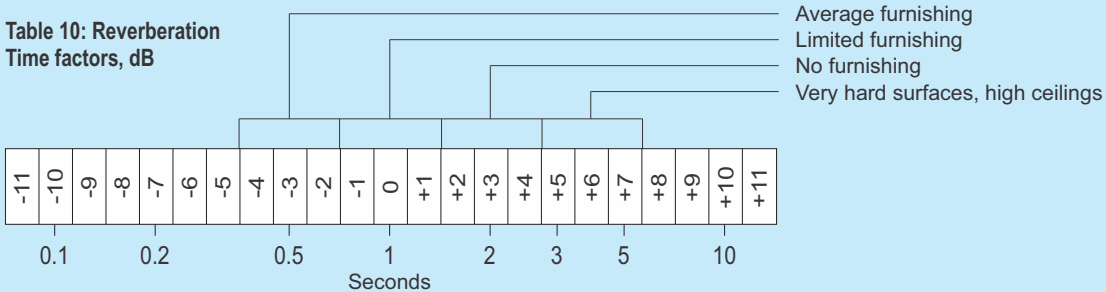

Note: reverberation time guide is applicable to typical rooms

Table 11: Addition of Sound Pressure Levels, dB

Differences in SPLs	Add to Large SPL
0.1	+3
2.3	+2
4,5,6,7,8,9	+1
10+	+0

PART 4

How to find the *Required Insertion Loss*

Q- The specification will usually give a criterion; where one is not given, Table 12 can be used.

The required or selected criterion is inserted in line "q".

R- If the Combined Sound Pressure Level exceeds the Criterion in any Octave Band, then the difference is the Insertion Loss required from the attenuator (line "r").

To allow for the possible addition of noise from other sources, a safety margin of typically 3dB may be added.

S- The attenuator can now be selected to meet the parameters of Insertion Loss, Physical Size and the Pressure Loss. The Insertion Loss Figures are placed in line "s" as a final check.

The above analysis method takes no account of regenerated noise from the attenuators or ductwork elements.

Similarly, it is not possible to deal with the method of selecting attenuators for high pressure systems which commonly have terminal devices that generate noise and often have some attenuation capability.

(Refer to Calculation Sheet Page 11)

Table 12: Recommended design criteria for various area functions (according to CIBSE)

SITUATION	NC
Concert halls, opera halls, studios for sound reproduction, live theatres (>500 seats)	20
Bedrooms in private homes, live theatres (<500 seats), cathedrals and large churches, television studios, large conference and lecture rooms (>50 people)	25
Living rooms in private homes, board rooms, top management offices, conference and lecture rooms (20-50 people), multi-purpose halls, churches (medium and small), libraries, bedrooms in hotels, etc., banqueting rooms, operating theatres, cinemas, hospital private rooms, large courtrooms	30
Public rooms in hotels, etc., ballrooms, hospital open wards, middle management and small offices, small conference and lecture rooms (<20 people), school classrooms, small courtrooms, museums, libraries, banking halls, small restaurants, cocktail bars, quality shops	35
Toilets and washrooms, large open offices, drawing offices, reception areas (offices), halls, corridors, lobbies in hotels, hospitals, etc., laboratories, recreation rooms, post offices, large restaurants, bars and night clubs, department stores, shops, gymnasia	40
Kitchens in hotels, hospitals, etc., laundry rooms, computer rooms, accounting machine rooms, cafeteria, supermarkets, swimming pools, covered garages in hotels, offices, etc., bowling alleys	45



Sound Attenuators

ROOMSIDE CALCULATION SHEET

DUCT VENTILATION AIR CONDITIONING Co. (W.L.L.)

DOHA- QATAR - PHONE: +974-44500118 - +974-44500119 - FAX: +974-44500117

CALCULATION SHEET

Customer Name :												
Project Name :				63	125	250	500	1k	2k	4k	8k	
Fan Duty :												
Type :												
System :				In-duct Sound Power								
Duct / Bend	Width x Height	Length / Angle	Type									
Outlet reflection				x								
Total duct attenuator (b + c)												
SWL Leavnig system												
Percentage leaving outlet												
Distance from outlet												
Directivity												
Total direct factors (f + g + h)												
Direct SPL												
Percentage reaching room												
Room volume												
Reverberation time												
Total reverberant factors (k + l + m)												
Reverberant SPL												
Combined SPL												
Criterion												
Required insertion loss												
Selected insertion loss												
Selection Code:												
				NC 55	74	67	62	58	56	54	53	52
				NR 55	79	70	63	58	55	52	50	49
				NC 50	71	64	58	54	51	49	48	47
				NR 50	75	65	59	53	50	47	45	43
				NC 45	67	60	54	49	46	44	43	42
				NR 45	71	61	54	48	45	42	40	38
				NC 40	64	57	50	45	41	39	38	37
				NR 40	67	57	49	44	40	37	35	33
				NC 35	60	52	45	40	36	34	33	32
				NR 35	63	52	45	39	35	32	30	28
				NC 30	57	48	41	35	31	29	28	27
				NR 30	59	48	40	34	30	27	25	23
				NC 25	54	44	37	31	27	24	22	21
				NR 25	55	44	35	29	25	22	20	18
				NC 20	51	40	33	26	22	19	17	16
				NR 20	51	39	31	24	20	17	14	13

1- GENERAL

- A. The Sound Attenuator is mainly used to reduce FCU and AHU Noise to obtain the required noise level; It offers many advanced features including as standard, Aerodynamic Splitters, Side Liners, Slide on Flanges and Protective Acoustic Infill with Galvanized Perforated Sheet.
- B. **DVAC** Sound Attenuators have been tested and certified in accordance to ASTM E477-06A, dynamic insertion loss and self noise acoustic performance data were obtained in AMCA (USA) test facility, using the duct-to-room reverberant test facility with air flowing through the Silencers.

2- TEST METHOD

The Laboratory method used in conducting these tests is ASTM Standard E477-06a, entitled "Standard Method of Testing Duct Liner Materials and Prefabricated Silencers for Acoustical and Airflow Performance". Sound pressure level data was obtained using a Brüel and Kjær Pulse Frequency Analyzer.

The Intertech 16,640 cu. Ft. (470 m³) reverberation room is qualified in accordance with ANSI S12.51 for sound measurement from 50 to 10,000 hertz.

The following notes relate to the data submitted in the data pages.

Notes:

- 1- Sound Power Level Data denoted with a double asterisk has reached ambient levels in the test room or is determined by instruments limitations. Actual levels are less than or equal to the levels indicated. The generated sound data has been corrected for end reflection.
Sound power level data denoted with a single asterisk has reached ambient levels and is being corrected.
- 2- Insertion Loss Data denoted with a single asterisk has been corrected to take into consideration the effect of the generated Sound Pressure Level approaching the sound pressure level obtained during the insertion loss portion of the test. In some cases, the insertion loss may be higher than shown. Insertion loss data denoted with a double asterisk has reached the maximum allowable correction and is not corrected.



1- MATERIALS

- A. Casings: Shall be made of 20 Gauge LFQ Galvanized Steel complying with ASTM A653 and having G90 Coating Designation.
- B1. Splitters: Shall be made of 24 Gauge LFQ Galvanized Steel complying with ASTM A653 and having G90 Coating Designation.
- B2. Perforated Sheets: Shall be made of 22 Gauge Galvanized Steel complying with ASTM A653 and having G90 Coating Designation, with a free area of 22.5%
- C. Fiberglass: Black, Strong, Durable, Dimensionally Stable Woven Glass Fabric (32 kg/m³ Density) complying with the following Standards:
- Surface Burning Characteristics: UL 723, ASTM E84, BS 476.
 - Fire Resistance: - NFPA 90A&B, NFPA 255.
 - Flamespread Classification not more than 25
 - Smoke Development Rating not more than 50

2- CONSTRUCTION

- A. All Casings shall be constructed of 20 Gauge GI Sheets; The construction complies with DW144 & SMACNA Standards.
- B. Slide-on-Flange will be fixed on Casing by Clinching & Self-Screws; Angle Flanges will be fixed on Casing by Bolts & Nuts.
- C. The Splitter modules are constructed from GI Sheets. All Splitters will be fixed by Aluminum Rivets minimum $\phi 4.8$ mm. All Splitter Corners shall be having a radius to minimize the Air Pressure Loss and regenerated noise & shall be fixed on both sides of the splitters. The acoustic material shall be fixed between the 2 perforated sheets. Air is allowed to pass through the airways between the splitters while noise is absorbed by the acoustic material.
- D. Standard Connectors: Slip-on-Flanges 30.
Optional: - Slip-on-Flange 20
- Slip-on-Flange 40.
- Companion Angle.

DVAC Rectangular Silencers Standard Lengths:

900mm, 1200mm, 1500mm, 1800mm, 2100mm & 2400mm

3- ACOUSTIC PERFORMANCE

- A. All silencer ratings shall be determined in a duct-to-reverberant room test facility which provides for airflow in both directions through the test silencer in accordance with ASTM Specs. E477-06a. The test facility shall be NVLAP accredited for the ASTM E477-06a Test Standard.

Data from a non-accredited laboratory will not be acceptable. The test set-up and procedure shall be such that all effects due to end reflection, directivity, flanking transmission, standing waves and test chamber sound absorption are eliminated.

Acoustic Ratings shall include Dynamic Insertion Loss (DIL) and Self-Noise (SN) Power Levels both for FORWARD FLOW (air and noise in same direction) and REVERSE FLOW (air and noise in opposite directions) with airflow of at least 2000 fpm entering face velocity.

Data for Rectangular Silencers shall be presented for tests conducted using silencers no smaller than 24x24'

4- AERODYNAMIC PERFORMANCE

- A. Static pressure loss of silencers shall not exceed those listed in the silencer schedule as the airflow indicates.

Airflow measurements shall be made in accordance with ASTM specification E477-06a and applicable portions of ASME, AMCA and ADC Airflow Test Codes.

INSTALLATION GUIDELINES

- Radius Bend

	L1 & L2	ΔP FACTOR
Radius Bend with Turning Vanes	Deq X 3.0	1.00
	Deq X 2.0	1.25
	Deq X 1.0	1.75
	Deq X 0.5	3.00
	Directly Connected	Not Advised
Radius Bend without Turning Vanes	Deq X 3.0	1.00
	Deq X 2.0	1.50
	Deq X 1.0	2.00

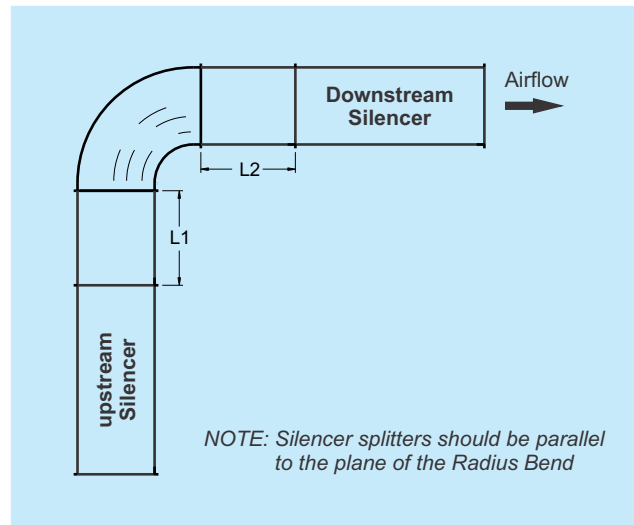

- Vane Axial Fan

	L1	L2	ΔP FACTOR
Rectangular Silencer	Not Less than 0.75 X Deq	Not Less than 1 X Deq for Every 1000 fpm Duct Velocity	1.00

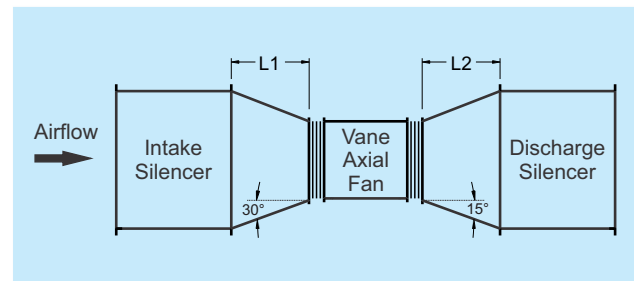

- Transitions

	ΔP FACTOR	
	Upstream	Downstream
With 15° included angle (7.5° slope)	1.00	1.00
With 30° included angle (15° slope)	1.25	1.00
With 60° included angle (30° slope)	1.50	1.00

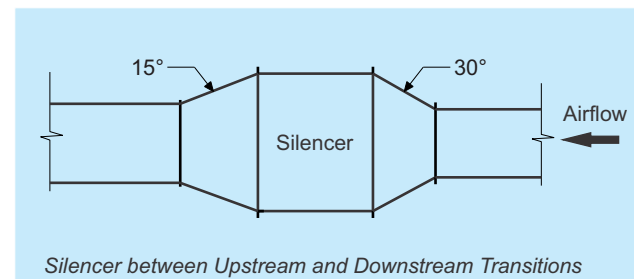

INSTALLATION GUIDELINES

- Ducted Centrifugal Fans

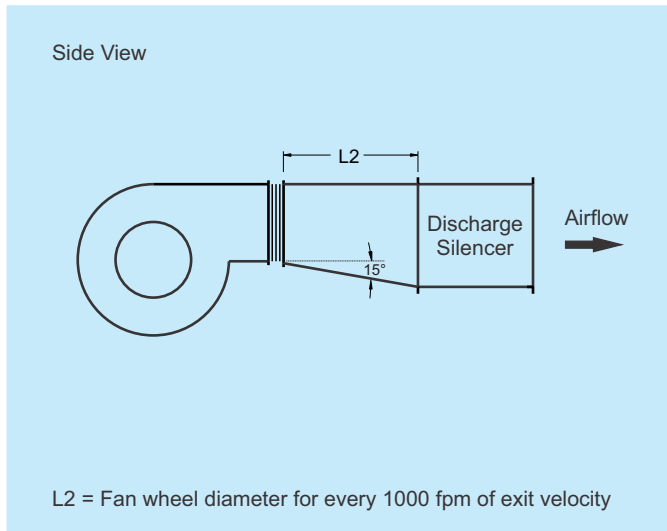
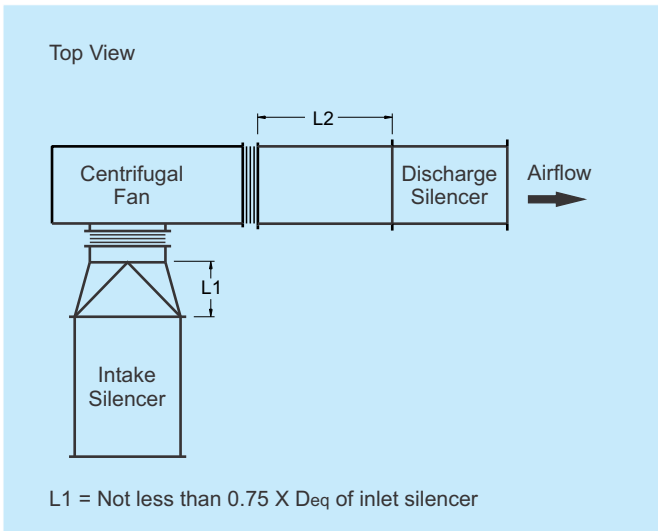

MULTIPLE MODULES ASSEMBLY

Commercial Acoustics Rectangular Sound Attenuators are supplied in multiple modules of many different sizes for convenience and economy in shipping, handling and installation. When Sound Attenuator banks are large, multiple modules are shipped loose for erection at the job site. To avoid possible leaks and damage, two factors need to be considered: the first, fastening the individual sound attenuator modules together, second, sealing the joints between assembled modules to prevent leakage. There are many methods of assembling and sealing multiple modules. The best of which should be determined by the installing contractor.

ASSEMBLY

The multiple modules should be drawn together using at least two steel bands or straps. Lightweight structural angles can be used as a frame and also facilitate attachment to the duct. Tack welds, made along each adjoining surface, will provide added structural integrity.

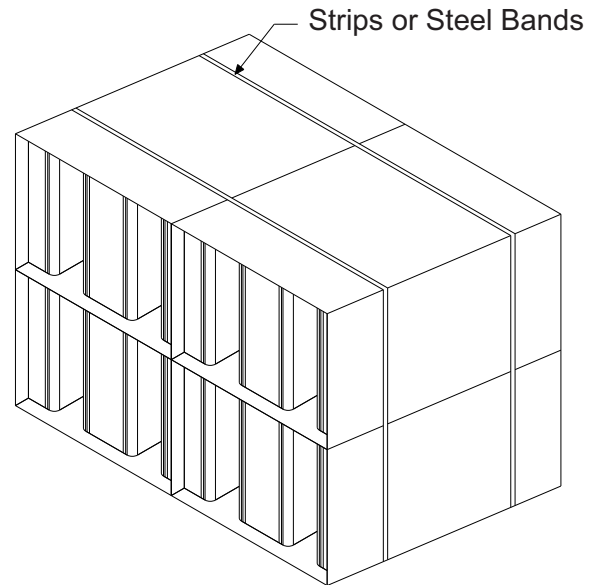

NOTES:

1. For **Circular Ducts**: "D_{eq}" = Duct Diameter. For **Square or Rectangular Ducts**: "D_{eq}" = $\sqrt{(4/\pi) \times \text{area}}$
2. ΔP Factor is multiplier relative to silencer laboratory tested pressure drop data.
3. Unless noted otherwise, ΔP Factors do not include pressure losses of other components (Transitions, Elbows, Dump Losses, etc..) which must be calculated separately.
4. The ΔP Factors shown are subject to minimum Duct runs of 5 x D_{eq} after Outlet Silencers and 2.5 x D_{eq} before Inlet Silencers.



DUCT VENTILATION AIR CONDITIONING Co. (W.L.L.)

Sound Attenuators

RECTANGULAR

Type RSA - Model: RSA3'-20-10

DOHA- QATAR - PHONE: +974-44500118 - +974-44500119 - FAX: +974-44500117

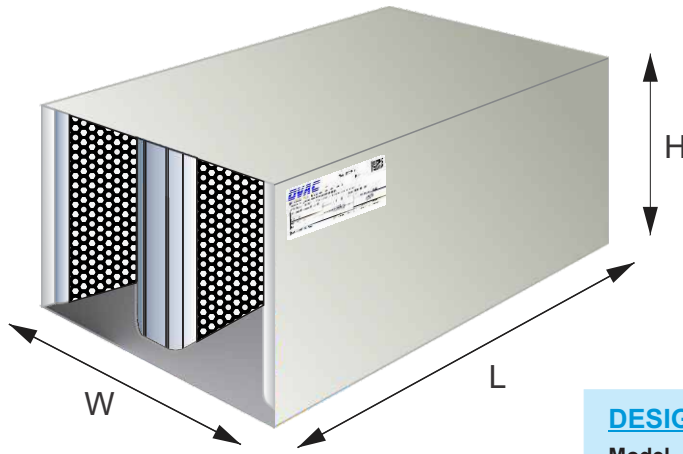

DVAC Silencers have been tested in accordance with applicable sections ASTM E-477-06a. Dynamic Insertion Loss and Self-Noise Acoustic Performance Data were obtained in AMCA, USA Test Facility using the duct-to-room reverberant with air flowing through the silencers.

Forward Flow (+) occurs when noise and air travel in same Direction as in a typical supply or fan discharge system.

Reverse Flow (-) occurs when noise and air travel in opposite directions, as in a typical return or intake system.

DESIGNATING SILENCERS

Model : RSA3'-20-10

Length: 3' Type: RSA Width: 24" Height: 24"



For Weight See page 23

Table 13. Dynamic Insertion Loss (DIL) Ratings: Forward (+) / Reverse (-) Flow, dB

Model	Octave Band		1	2	3	4	5	6	7	8
	Hz		63	125	250	500	1k	2k	4k	8k
	Face Velocity (fpm)	Static Pressure (iwg)								
RSA3'-20-10	-1500	0.78	6	10	18	27	32	23	16	12
	-1000	0.35	5	10	17	26	31	23	16	12
	-500	0.09	5	9	16	26	31	23	16	11
	0		2	7	14	24	30	24	17	13
	500	0.09	4	8	15	24	29	24	17	14
	1000	0.35	3	8	15	23	29	24	17	14
	1500	0.78	2	6	14	22	28	23	18	14
	2000	1.40	1	6	13	21	26	23	18	14

Table 14. Air Flow Generated Noise Power Levels, dB

Model	Octave Band		1	2	3	4	5	6	7	8
	Hz		63	125	250	500	1k	2k	4k	8k
	Face Velocity (fpm)	Static Pressure (iwg)								
RSA3'-20-10	-1500	0.78	64**	57*	54	58	63	65	63	51
	-1000	0.35	59**	49*	49	54	57	54	44	35
	-500	0.09	56**	46**	37**	41	36	25*	21**	22**
	500	0.09	60**	47**	37**	37	32	21**	20**	22**
	1000	0.35	61**	51*	48	51	52	48	42	29*
	1500	0.78	65**	63	57	58	61	60	57	48
	2000	1.40	76	70	65	64	65	67	65	58



Forward Flow (+) / Reverse Flow (-). Aero-acoustic performance data based on NVLAP accredited laboratory tests conducted in strict accordance with ASTM E477-06a.



DUCT VENTILATION AIR CONDITIONING Co. (W.L.L.)

Sound Attenuators

RECTANGULAR

Type RSA - Model: RSA4'-20-10

DOHA- QATAR - PHONE: +974-44500118 - +974-44500119 - FAX: +974-44500117

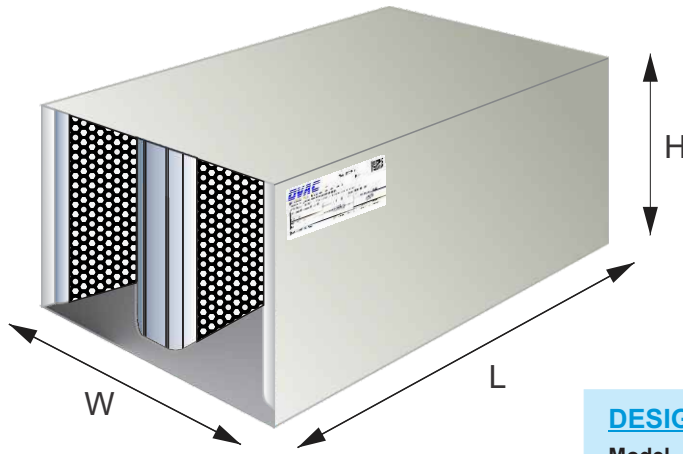

DVAC Silencers have been tested in accordance with applicable sections ASTM E-477-06a. Dynamic Insertion Loss and Self-Noise Acoustic Performance Data were obtained in AMCA, USA Test Facility using the duct-to-room reverberant with air flowing through the silencers.

Forward Flow (+) occurs when noise and air travel in same Direction as in a typical supply or fan discharge system.

Reverse Flow (-) occurs when noise and air travel in opposite directions, as in a typical return or intake system.

DESIGNATING SILENCERS

Model : RSA4'-20-10

Length: 4' Type: RSA Width: 24" Height: 24"



For Weight See page 23

Table 15. Dynamic Insertion Loss (DIL) Ratings: Forward (+) / Reverse (-) Flow, dB

Model	Octave Band		1	2	3	4	5	6	7	8
	Hz		63	125	250	500	1k	2k	4k	8k
	Face Velocity (fpm)	Static Pressure (iwg)								
RSA4'-20-10	-1500	0.83	4	13	22	34**	36**	27**	20	14
	-1000	0.38	3	12	22	35*	39*	31*	20	13
	-500	0.10	3	12	21	35	41	31	20	13
	0		2	10	19	34	40	31	21	15
	500	0.10	1	10	19	32	40	31	22	16
	1000	0.38	1	9	18	31	39	31	22	17
	1500	0.83	0	8	17	30	36*	31*	22	17
	2000	1.47	1	8	17	27*	32*	28**	22	18

Table 16. Air Flow Generated Noise Power Levels, dB

Model	Octave Band		1	2	3	4	5	6	7	8
	Hz		63	125	250	500	1k	2k	4k	8k
	Face Velocity (fpm)	Static Pressure (iwg)								
RSA4'-20-10	-1500	0.83	65**	57*	55	59	65	69	64	52
	-1000	0.38	59**	50**	49	54	57	55	45	35
	-500	0.10	55**	44**	37**	40	36	24*	22**	22**
	500	0.10	55**	43**	38**	39	35	24**	20**	22**
	1000	0.38	59**	52*	49	52	54	50	43	31*
	1500	0.83	65**	63	58	59	61	60	56	48
	2000	1.47	78	70	66	65	66	67	65	58



Forward Flow (+) / Reverse Flow (-). Aero-acoustic performance data based on NVLAP accredited laboratory tests conducted in strict accordance with ASTM E477-06a.



DUCT VENTILATION AIR CONDITIONING Co. (W.L.L.)

Sound Attenuators

RECTANGULAR

Type RSA - Model: RSA5'-20-10

DOHA- QATAR - PHONE: +974-44500118 - +974-44500119 - FAX: +974-44500117

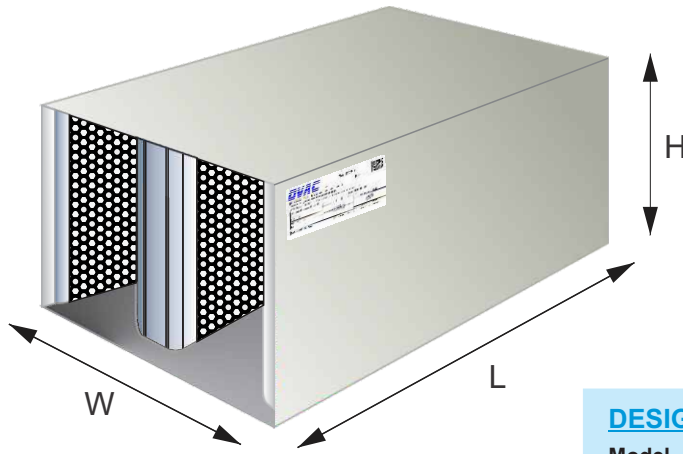

DVAC Silencers have been tested in accordance with applicable sections ASTM E-477-06a. Dynamic Insertion Loss and Self-Noise Acoustic Performance Data were obtained in AMCA, USA Test Facility using the duct-to-room reverberant with air flowing through the silencers.

Forward Flow (+) occurs when noise and air travel in same Direction as in a typical supply or fan discharge system.

Reverse Flow (-) occurs when noise and air travel in opposite directions, as in a typical return or intake system.

DESIGNATING SILENCERS

Model : RSA5'-20-10

Length: 5' Type: RSA Width: 24" Height: 24"



For Weight See page 23

Table 17. Dynamic Insertion Loss (DIL) Ratings: Forward (+) / Reverse (-) Flow, dB

Model	Octave Band		1	2	3	4	5	6	7	8
	Hz		63	125	250	500	1k	2k	4k	8k
	Face Velocity (fpm)	Static Pressure (iwg)								
RSA5'-20-10	-1500	1.00	8	18	28*	36**	37**	30**	24**	16
	-1000	0.44	7	17	27	40**	41**	36**	24	16
	-500	0.12	7	15	26	41	47	37	24	16
	0		4	13	25	39	47	38	25	18
	500	0.12	3	12	24	38	46	38	25	19
	1000	0.44	3	12	23	36	43*	37	25	20
	1500	1.00	2	11	22*	33*	38**	35**	25	20
	2000	1.72	1	11	20**	28**	34**	30**	25*	20

Table 18. Air Flow Generated Noise Power Levels, dB

Model	Octave Band		1	2	3	4	5	6	7	8
	Hz		63	125	250	500	1k	2k	4k	8k
	Face Velocity (fpm)	Static Pressure (iwg)								
RSA5'-20-10	-1500	1.00	65**	55*	55	59	64	67	67	54
	-1000	0.44	59**	48**	49	53	57	56	47	36
	-500	0.12	56**	43**	37**	41	39	28	21**	22**
	500	0.12	60**	47**	39**	39	35	25*	20**	22**
	1000	0.44	62**	52*	49	51	52	48	42	30*
	1500	1.00	67**	62	58	58	60	60	56	48
	2000	1.72	72*	69	65	64	65	66	64	58



Forward Flow (+) / Reverse Flow (-). Aero-acoustic performance data based on NVLAP accredited laboratory tests conducted in strict accordance with ASTM E477-06a.



DUCT VENTILATION AIR CONDITIONING Co. (W.L.L.)

Sound Attenuators

RECTANGULAR

Type RSA - Model: RSA6'-20-10

DOHA- QATAR - PHONE: +974-44500118 - +974-44500119 - FAX: +974-44500117

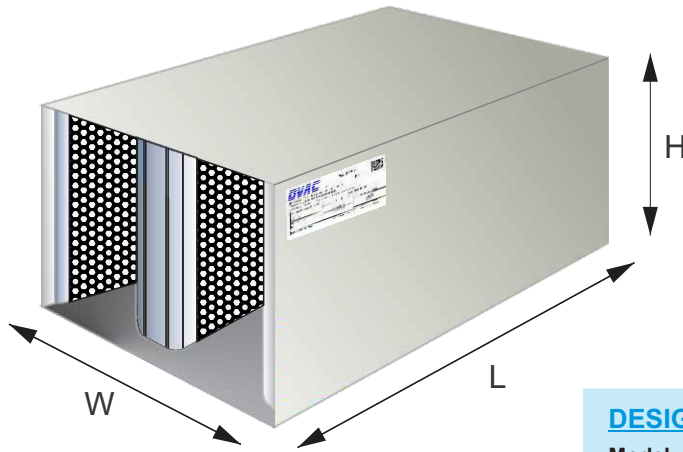

DVAC Silencers have been tested in accordance with applicable sections ASTM E-477-06a. Dynamic Insertion Loss and Self-Noise Acoustic Performance Data were obtained in AMCA, USA Test Facility using the duct-to-room reverberant with air flowing through the silencers.

Forward Flow (+) occurs when noise and air travel in same Direction as in a typical supply or fan discharge system.

Reverse Flow (-) occurs when noise and air travel in opposite directions, as in a typical return or intake system.

DESIGNATING SILENCERS

Model : RSA6'-20-10

Length: 6' Type: RSA Width: 24" Height: 24"



For Weight See page 23

Table 19. Dynamic Insertion Loss (DIL) Ratings: Forward (+) / Reverse (-) Flow, dB

Model	Octave Band		1	2	3	4	5	6	7	8
	Hz		63	125	250	500	1k	2k	4k	8k
	Face Velocity (fpm)	Static Pressure (iwg)								
RSA6'-20-10	-1500	1.00	6	19	31**	34**	36**	30**	26**	17
	-1000	0.44	5	18	34**	38**	40**	38**	27	17
	-500	0.12	5	17	34	42	51	44	26	17
	0		3	15	33	42	51	44	28	20
	500	0.12	4	14	32	41	51	44	29	21
	1000	0.44	3	13	30	39**	45**	43*	29	22
	1500	1.00	2	13	27*	34**	39**	37**	29	22
	2000	1.72	1	12	22**	29**	34**	31**	29**	23

Table 20. Air Flow Generated Noise Power Levels, dB

Model	Octave Band		1	2	3	4	5	6	7	8
	Hz		63	125	250	500	1k	2k	4k	8k
	Face Velocity (fpm)	Static Pressure (iwg)								
RSA6'-20-10	-1500	1.00	66**	57*	57	60	65	67	65	53
	-1000	0.44	61**	49*	51	55	58	57	47	37
	-500	0.12	62**	45**	36**	40	35	24*	21**	22**
	500	0.12	61**	47**	37*	39	35	25*	20**	22**
	1000	0.44	58**	52*	48	51	52	48	42	29*
	1500	1.00	66**	63	58	58	60	60	56	48
	2000	1.72	73*	71	66	64	65	66	64	58



Forward Flow (+) / Reverse Flow (-). Aero-acoustic performance data based on NVLAP accredited laboratory tests conducted in strict accordance with ASTM E477-06a.



DUCT VENTILATION AIR CONDITIONING Co. (W.L.L.)

Sound Attenuators

RECTANGULAR

Type RSA - Model: RSA7'-20-10

DOHA- QATAR - PHONE: +974-44500118 - +974-44500119 - FAX: +974-44500117



DVAC Silencers have been tested in accordance with applicable sections ASTM E-477-06a. Dynamic Insertion Loss and Self-Noise Acoustic Performance Data were obtained in AMCA, USA Test Facility using the duct-to-room reverberant with air flowing through the silencers.

Forward Flow (+) occurs when noise and air travel in same Direction as in a typical supply or fan discharge system.

Reverse Flow (-) occurs when noise and air travel in opposite directions, as in a typical return or intake system.

DESIGNATING SILENCERS

Model : RSA7'-20-10

Length: 7' Type: RSA Width: 24" Height: 24"



For Weight See page 23

Table 21. Dynamic Insertion Loss (DIL) Ratings: Forward (+) / Reverse (-) Flow, dB

Model	Octave Band		1	2	3	4	5	6	7	8
	Hz		63	125	250	500	1k	2k	4k	8k
	Face Velocity (fpm)	Static Pressure (iwg)								
RSA7'-20-10	-1500	1.07	8	24	33**	37**	37**	31**	28**	19
	-1000	0.49	8	22	35**	41**	42**	40**	30	19
	-500	0.13	7	21	34	50*	52*	48	30	19
	0		5	18	33	52	51	47	31	22
	500	0.13	3	17	32	50*	51	47	32	23
	1000	0.49	3	16	31*	42**	45**	45**	32	24
	1500	1.07	2	15	27**	35**	39**	37**	32*	25
	2000	1.91	2	14	21**	28**	34**	31**	31**	25

Table 22. Air Flow Generated Noise Power Levels, dB

Model	Octave Band		1	2	3	4	5	6	7	8
	Hz		63	125	250	500	1k	2k	4k	8k
	Face Velocity (fpm)	Static Pressure (iwg)								
RSA7'-20-10	-1500	1.07	64**	54*	54	58	64	67	67	63
	-1000	0.49	61**	49**	50	54	58	57	47	37
	-500	0.13	56**	44**	37**	42	39	28	21**	22**
	500	0.13	57**	45**	38**	38	34	24*	21**	22**
	1000	0.49	60**	54	50	51	52	48	42	30
	1500	1.07	66**	64	60	59	60	60	56	48
	2000	1.91	73*	71	67	65	65	66	64	59



Forward Flow (+) / Reverse Flow (-). Aero-acoustic performance data based on NVLAP accredited laboratory tests conducted in strict accordance with ASTM E477-06a.



DUCT VENTILATION AIR CONDITIONING Co. (W.L.L.)

Sound Attenuators

RECTANGULAR

Type RSA - Model: RSA8'-20-10

DOHA- QATAR - PHONE: +974-44500118 - +974-44500119 - FAX: +974-44500117

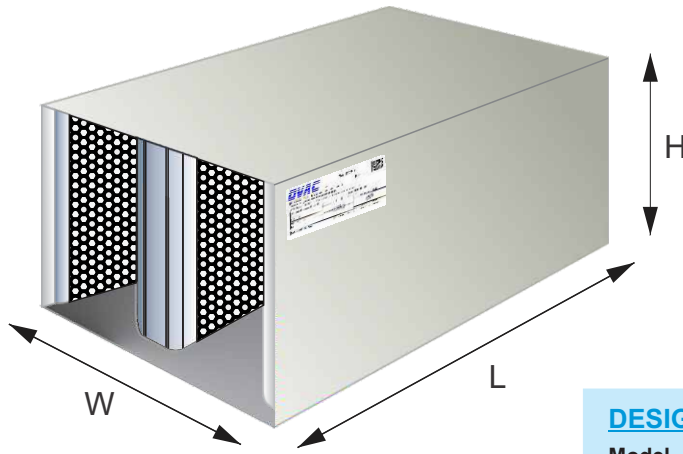

DVAC Silencers have been tested in accordance with applicable sections ASTM E-477-06a. Dynamic Insertion Loss and Self-Noise Acoustic Performance Data were obtained in AMCA, USA Test Facility using the duct-to-room reverberant with air flowing through the silencers.

Forward Flow (+) occurs when noise and air travel in same Direction as in a typical supply or fan discharge system.

Reverse Flow (-) occurs when noise and air travel in opposite directions, as in a typical return or intake system.

DESIGNATING SILENCERS

Model : RSA8'-20-10

Length: 8' Type: RSA Width: 24" Height: 24"



For Weight See page 23

Table 23. Dynamic Insertion Loss (DIL) Ratings: Forward (+) / Reverse (-) Flow, dB

Model	Octave Band		1	2	3	4	5	6	7	8
	Hz		63	125	250	500	1k	2k	4k	8k
	Face Velocity (fpm)	Static Pressure (iwg)								
RSA8'-20-10	-1500	1.28	9	24*	32**	36**	37**	30**	30**	21
	-1000	0.58	8	23	36**	40**	41**	38**	34*	21
	-500	0.15	8	22	37	51*	53*	52	34	21
	0		5	20	37	53	52	51	35	24
	500	0.15	4	19	35	52*	52	51	35	25
	1000	0.58	4	18	34**	42**	46**	47**	36	27
	1500	1.28	3	17	27**	34**	39**	37**	35*	28
2000	2.20	2	15*	21**	28**	34**	30**	32**	28	

Table 24. Air Flow Generated Noise Power Levels, dB

Model	Octave Band		1	2	3	4	5	6	7	8
	Hz		63	125	250	500	1k	2k	4k	8k
	Face Velocity (fpm)	Static Pressure (iwg)								
RSA8'-20-10	-1500	1.07	65**	55*	56	60	64	68	67	55
	-1000	0.49	59**	50**	51	54	58	59	49	40
	-500	0.13	56**	44**	37**	41	37	26*	20**	22**
	500	0.13	60**	47**	38**	38	34	24*	20**	22**
	1000	0.49	62**	55	50	52	53	50	44	32
	1500	1.07	67**	64	59	59	60	60	56	49
	2000	1.91	73*	72	67	66	65	67	65	59



Forward Flow (+) / Reverse Flow (-). Aero-acoustic performance data based on NVLAP accredited laboratory tests conducted in strict accordance with ASTM E477-06a.



DUCT VENTILATION AIR CONDITIONING Co. (W.L.L.)

Sound Attenuators

RECTANGULAR

AIRFLOW PERFORMANCE (Type: RSA)

DOHA- QATAR - PHONE: +974-44500118 - +974-44500119 - FAX: +974-44500117

Table 25. Airflow Performance

Silencers's Length		Static Pressure Loss																			
ft	mm																				
3'	900	W.G.	0.044	0.090	0.137	0.197	0.268	0.350	0.439	0.542	0.655	0.780	0.924	1.072	1.230	1.400					
		Pa	10.985	22.418	34.055	49.039	66.748	87.181	109.288	134.923	163.257	194.289	230.213	266.992	306.496	348.724					
4'	1200	W.G.	0.049	0.100	0.148	0.214	0.291	0.380	0.467	0.576	0.697	0.830	0.970	1.125	1.292	1.470					
		Pa	12.205	24.909	36.974	53.243	72.469	94.654	116.293	143.572	173.722	206.744	241.723	280.342	321.821	366.161					
5'	1500	W.G.	0.059	0.120	0.172	0.248	0.337	0.440	0.563	0.694	0.840	1.000	1.135	1.317	1.512	1.720					
		Pa	14.646	29.891	42.812	61.650	83.912	109.599	140.113	172.978	209.304	249.089	282.833	328.019	376.552	428.433					
6'	1800	W.G.	0.059	0.120	0.172	0.248	0.337	0.440	0.563	0.694	0.840	1.000	1.135	1.317	1.512	1.720					
		Pa	14.646	29.891	42.812	61.650	83.912	109.599	140.113	172.978	209.304	249.089	282.833	328.019	376.552	428.433					
7'	2100	W.G.	0.064	0.130	0.191	0.276	0.375	0.490	0.602	0.743	0.899	1.070	1.261	1.462	1.679	1.910					
		Pa	15.867	32.382	47.677	68.655	93.447	122.054	149.920	185.087	223.955	266.525	314.076	364.254	418.148	475.760					
8'	2400	W.G.	0.074	0.150	0.227	0.326	0.444	0.580	0.720	0.889	1.076	1.280	1.452	1.684	1.934	2.200					
		Pa	18.308	37.363	56.434	81.265	110.611	144.472	179.344	221.412	267.909	318.834	361.763	419.559	481.637	547.996					
Face Velocity (fpm)		350	500	625	750	875	1000	1125	1250	1375	1500	1625	1750	1875	2000						
Width		Height		Face Area		Air Flow (cfm)															
in	mm	in	mm	ft ²	m ²																
12	300	12	300	1	0.09	350	500	625	750	875	1000	1125	1250	1375	1500	1625	1750	1875	2000		
24	600	12	300	2	0.18	700	1000	1250	1500	1750	2000	2250	2500	2750	3000	3250	3500	3750	4000		
24	600	18	450	3	0.27	1050	1500	1875	2250	2625	3000	3375	3750	4125	4500	4875	5250	5625	6000		
24	600	21	525	3.5	0.31	1225	1750	2188	2625	3063	3500	3938	4375	4813	5250	5688	6125	6563	7000		
24	600	24	600	4	0.36	1400	2000	2500	3000	3500	4000	4500	5000	5500	6000	6500	7000	7500	8000		
36	900	12	300	3	0.27	1050	1500	1875	2250	2625	3000	3375	3750	4125	4500	4875	5250	5625	6000		
36	900	18	450	4.5	0.40	1575	2250	2813	3375	3938	4500	5063	5625	6188	6750	7313	7875	8438	9000		
36	900	20	500	5	0.45	1750	2500	3125	3750	4375	5000	5625	6250	6875	7500	8125	8750	9375	10000		
36	900	24	600	6	0.54	2100	3000	3750	4500	5250	6000	6750	7500	8250	9000	9750	10500	11250	12000		
36	900	28	700	7	0.63	2450	3500	4375	5250	6125	7000	7875	8750	9625	10500	11375	12250	13125	14000		
36	900	32	800	8	0.72	2800	4000	5000	6000	7000	8000	9000	10000	11000	12000	13000	14000	15000	16000		
36	900	36	900	9	0.81	3150	4500	5625	6750	7875	9000	10125	11250	12375	13500	14625	15750	16875	18000		
48	1200	12	300	4	0.36	1400	2000	2500	3000	3500	4000	4500	5000	5500	6000	6500	7000	7500	8000		
48	1200	18	450	6	0.54	2100	3000	3750	4500	5250	6000	6750	7500	8250	9000	9750	10500	11250	12000		
48	1200	21	525	7	0.63	2450	3500	4375	5250	6125	7000	7875	8750	9625	10500	11375	12250	13125	14000		
48	1200	24	600	8	0.72	2800	4000	5000	6000	7000	8000	9000	10000	11000	12000	13000	14000	15000	16000		
48	1200	30	750	10	0.90	3500	5000	6250	7500	8750	10000	11250	12500	13750	15000	16250	17500	18750	20000		
48	1200	36	900	12	1.08	4200	6000	7500	9000	10500	12000	13500	15000	16500	18000	19500	21000	22500	24000		
48	1200	42	1050	14	1.26	4900	7000	8750	10500	12250	14000	15750	17500	19250	21000	22750	24500	26250	28000		
48	1200	48	1200	16	1.44	5600	8000	10000	12000	14000	16000	18000	20000	22000	24000	26000	28000	30000	32000		
60	1500	12	300	5	0.45	1750	2500	3125	3750	4375	5000	5625	6250	6875	7500	8125	8750	9375	10000		
60	1500	18	450	7.5	0.67	2625	3750	4688	5625	6563	7500	8438	9375	10313	11250	12188	13125	14063	15000		
60	1500	24	600	10	0.90	3500	5000	6250	7500	8750	10000	11250	12500	13750	15000	16250	17500	18750	20000		
60	1500	30	750	12.5	1.12	4375	6250	7813	9375	10938	12500	14063	15625	17188	18750	20313	21875	23438	25000		
60	1500	36	900	15	1.35	5250	7500	9375	11250	13125	15000	16875	18750	20625	22500	24375	26250	28125	30000		
60	1500	42	1050	17.5	1.57	6125	8750	10938	13125	15313	17500	19688	21875	24063	26250	28438	30625	32813	35000		
60	1500	48	1200	20	1.80	7000	10000	12500	15000	17500	20000	22500	25000	27500	30000	32500	35000	37500	40000		
60	1500	54	1350	22.5	2.02	7875	11250	14063	16875	19688	22500	25313	28125	30938	33750	36563	39375	42188	45000		
60	1500	60	1500	25	2.25	8750	12500	15625	18750	21875	25000	28125	31250	34375	37500	40625	43750	46875	50000		



Forward Flow (+) / Reverse Flow (-). Aero-acoustic performance data based on NVLAP accredited laboratory tests conducted in strict accordance with ASTM E477-06a.





DUCT VENTILATION AIR CONDITIONING Co. (W.L.L.)

Sound Attenuators

RECTANGULAR

WEIGHTS (Type: RSA)

DOHA- QATAR - PHONE: +974-44500118 - +974-44500119 - FAX: +974-44500117

Table 26. Weights (Type: RSA)

Weights of RSA - Width 12" to 36"														
Silencers's Size		Width (in)	12	24	24	24	24	36	36	36	36	36	36	
		Height (in)	12	12	18	21	24	12	18	20	24	28	32	36
		Width (mm)	300	600	600	600	600	900	900	900	900	900	900	900
		Height (mm)	300	300	450	525	600	300	450	500	600	700	800	900
Silencers's Length		Weight = 10%												
ft	mm													
3'	900	lbs	39	67	84	92	101	95	117	125	139	154	168	183
		kg	18	30	38	42	46	43	53	57	63	70	76	83
4'	1200	lbs	52	88	110	121	130	125	153	163	182	201	220	239
		kg	24	40	50	55	59	57	70	74	83	91	100	109
5'	1500	lbs	64	110	136	150	171	155	190	202	228	248	272	295
		kg	29	50	62	68	78	70	86	92	104	113	124	134
6'	1800	lbs	77	131	162	178	197	185	226	240	268	295	323	351
		kg	35	60	74	81	90	84	103	109	122	134	147	160
7'	2100	lbs	89	152	188	207	226	215	263	279	311	342	375	407
		kg	40	69	85	94	103	98	120	127	141	155	170	185
8'	2400	lbs	102	173	215	235	255	244	299	317	354	390	426	463
		kg	46	79	98	107	116	111	136	144	161	177	194	210



Weights of RSA - Width 48" to 60"																			
Silencers's Size		Width (in)	48	48	48	48	48	48	48	48	60	60	60	60	60	60	60		
		Height (in)	12	18	21	24	30	36	42	48	12	18	24	30	36	42	48	54	60
		Width (mm)	1200	1200	1200	1200	1200	1200	1200	1200	1500	1500	1500	1500	1500	1500	1500	1500	1500
		Height (mm)	300	450	525	600	750	900	1050	1200	300	450	600	750	900	1050	1200	1350	1500
Silencers's Length		Silencers's Weight = 10%																	
ft	mm																		
3'	900	lbs	123	150	164	178	205	233	261	289	150	184	217	250	283	316	350	383	540
		kg	56	68	75	81	93	106	119	131	68	84	99	114	129	143	159	174	245
4'	1200	lbs	161	197	215	232	269	304	340	376	198	240	283	326	369	411	454	497	663
		kg	73	90	98	105	122	138	155	171	90	109	129	148	168	186	206	226	301
5'	1500	lbs	200	244	265	287	331	374	419	463	245	297	350	402	454	507	559	612	788
		kg	91	111	120	130	150	170	190	210	111	135	159	183	206	230	254	278	358
6'	1800	lbs	238	290	316	342	394	446	498	550	292	354	416	478	540	602	664	726	912
		kg	108	132	144	155	179	203	226	250	133	161	189	217	245	273	302	330	415
7'	2100	lbs	276	337	367	397	456	516	576	636	339	411	482	554	625	697	769	840	912
		kg	125	153	167	180	207	235	262	289	154	187	219	252	284	316	350	382	415
8'	2400	lbs	315	383	417	451	519	587	655	723	386	467	549	630	711	792	873	954	1,035
		kg	143	174	190	205	236	267	298	329	175	212	250	286	323	359	397	434	470



Forward Flow (+) / Reverse Flow (-). Aero-acoustic performance data based on NVLAP accredited laboratory tests conducted in strict accordance with ASTM E477-06a.

1- GENERAL

A. The Circular Sound Attenuator is mainly used to reduce FCU and AHU noise to obtain the required noise level. The Circular Sound Attenuator offers many advanced features including as standard, Aerodynamic pod, side liners, flanges and protective acoustic Infill with galvanized perforated sheet metal.

2- MATERIALS

- A. **Casings:** All Casings shall be made of LFQ Galvanized Steel complying with ASTM A653 and having G90 Coating Designation. (For Thickness See Table 27)
- B. **Perforated Sheets:** Shall be made of LFQ Galvanized steel complying with ASTM A653 and Having G90 Coating Designation with a Free Area of 22.5% (For Thickness See Table 27)
- C. **Fiberglass:** Black, Strong, Durable, Dimensionally Stable Woven Glass Fiber (32 kg/m³ Density) complying with the following standards:
 - Surface Burning Characteristics: UL 723, ASTM E84, BS 476.
 - Fire Resistance: - NFPA 90A & B, NFPA 255.
 - Flamespread Classification not more than 25
 - Smoke Development Rating not more than 50
- D. **Pods:** Shall be made of 24 gauge LFQ Galvanized steel complying with ASTM A653 and Having G90 Coating Designation with a Free Area of 22.5%

3- CONSTRUCTION

- A. All Casings shall be constructed of Galv. Sheets complying with DW144 & SMACNA Standards. The Casing shall be fabricated with Spiral Machine and having the shape of Spiral Tube.
- B. Perforated Inner Skin shall be constructed of GI Sheets fabricated with Spiral Machine; it will be fixed with Flat Flange having the shape of Spiral Tube.
- C. Pods: Perforated Pods shall be constructed of GI Sheets fabricated with the Spiral Machine & will be fixed by GI Cross Flat Bar, THK 3mm.
- D. Standard Connections: - Coupling
 - Flat Flange
 - Angle Flange

(For Connectors See Table 28)

DVAC Circular Silencers Standard Lengths:

900mm, 1200mm, 1500mm, 1800mm,
2100mm, 2400mm & 3000mm

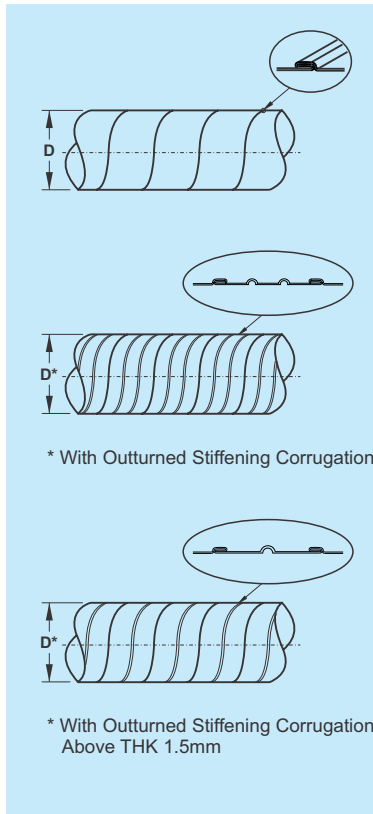
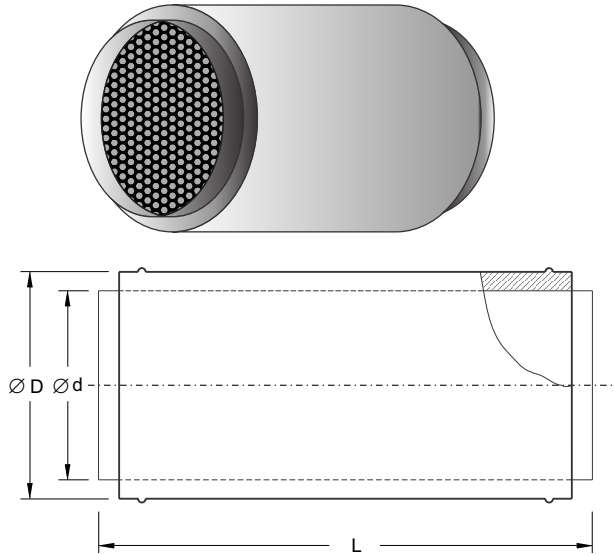

Table 27: Casings Thickness for (Type: CASA & CBSA)

Casing Thickness	
Standard Diameter (mm)	Materials Thickness (mm)
	GI
100	0.5
125	0.5
140	0.5
150	0.5
160	0.5
180	0.5
200	0.5
224	0.5
250	0.5
280	0.6
300*	0.6
315*	0.6
355*	0.6
400*	0.7
450*	0.7
500*	0.7
550*	0.7
560*	0.7
600*	0.7
630*	0.8
650*	0.8
710*	0.8
750*	0.8
800*	0.8
850*	0.8
900*	0.8
950*	0.8
1000*	0.8
1050*	0.8
1100*	0.8
1120*	1.0
1150*	1.0
1200*	1.0
1250*	1.0
1300*	1.0
1350*	1.0
1400*	1.0
1450*	1.2
1500*	1.2
1600*	1.2
1800*	1.2
2000*	1.2
2300*	1.5
2500*	2.0

CIRCULAR SOUND ATTENUATOR - TYPE: CASA

The Inlet and Outlet connections can either be Plug-Type Spigot Or Flanged.



CIRCULAR SOUND ATTENUATOR - TYPE: CBSA

The Inlet and Outlet connections can either be Plug-Type Spigot Or Flanged having an additional sound-absorbing pod fitted In the center with a galvanized perforated sheet covering And coned end to reduce pressure loss.

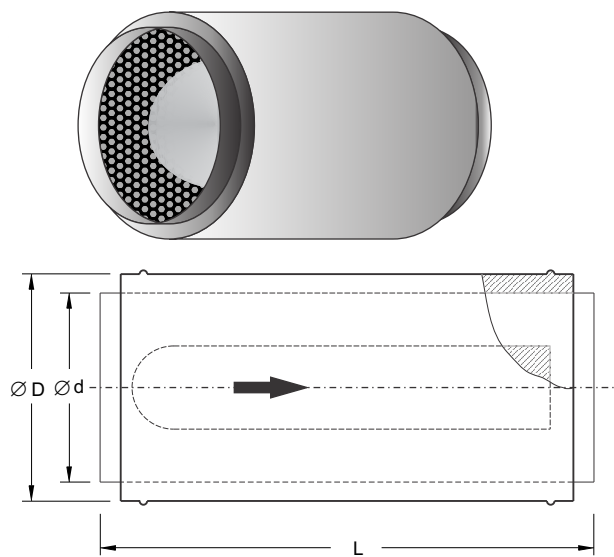
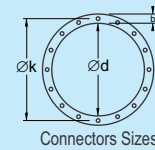

Table 28: Connectors for Types: CASA & CBSA

Connectors Flat & Angle Flange (Standard Diameter of Holes 9.0mm)			
Size (mm)	b x t (mm)	Ø k (mm)	No. of Holes
100	25 x 3	130	4
125	25 x 3	155	4
150	25 x 3	180	5
200	25 x 3	225	6
250	25 x 3	275	6
300	25 x 3	325	8
400	30 x 3	430	8
450	30x30x3	480	8
500	30x30x3	530	8
550	40x40x4	590	12
600	40x40x4	640	12
700	40x40x4	740	12
800	40x40x4	840	16
900	40x40x4	940	16
1000	40x40x4	1040	16



Connectors Sizes

Insulation Thickness: 50mm $\text{Ø D} = \text{Ø d} + 100\text{mm}$
 Insulation Thickness: 100mm $\text{Ø D} = \text{Ø d} + 200\text{mm}$

CALCULATION

To make the Calculation, DVAC works on the Silencer Software which provides the exact dimensions to be applied for the fabrication of the Silencer, depending on the Sound Level required by the Customer.

INPUT REQUIRED DATA

- 1- In Duct Sound Power Level or Sound Pressure Level
- 2- Distance between the Fan and the First Opening
- 3- Volume Flow Rate
- 4- Type of Silencer
- 5- Sound level & Size

The screenshot shows the 'Input Screen' of the Silencer Program. It includes a table of noise level data for 'CULTURAL VILLAGE' at various frequencies (63Hz to 8kHz) and a total of 93 dBA. Below the table are options for silencer type (Circular or Rectangular) and noise level definitions (In Duct or Free Field). A 'User Reference' table shows 'A' weighting factors and the resulting 'A' weighted spectrum of 86 dBA. At the bottom, it specifies a volume flow of 3040 L/S (3.040 M3/S) and an equipment connection diameter of 1400 mm.

1- OUTPUT DATA

There are several options to make selection of silencers. The selection will be done according to the data provided.

The screenshot displays the 'Manual Design' and 'Auto Design' sections of the software. It features a 3D diagram of a silencer with dimensions A, B, L, and N, and labels for '2 Side splitters' and 'N Internal splitters'. To the right, four different silencer styles (Style 1, 2, 3, 4) are shown with their respective airflow gap and connection details. The 'Auto Design' section includes a 'Calculate' button and a table of design options. The table lists silencer configurations with columns for SPL, Reg, N, Flow Gap, Friction Drop Pa, V.P. Diff Pa, Approx Cost \$, Weight KG, Sil Style, and various dimensions (Dim 'A', 'B', 'L', 'U', 'W', 'X', 'Thk').

Sil No	SPL dBA	Reg	N	Flow Gap	Friction Drop Pa	V.P. Diff Pa	Approx Cost \$	Weight KG	Sil Style	Dim 'A'	Dim 'B'	Length 'L'	Dim 'U'	Dim 'W'	Dim 'X'	Body Thk	
12	34	17	2	167	11.0	23.0	64.0	992	260.1	2	1400	550	1200	150	300	0	1.6
13	31	16	2	167	11.0	25.0	64.0	1360	340.0	2	1400	550	1500	150	300	0	1.6
14	27	14	2	167	11.0	27.0	64.0	1476	381.9	2	1400	550	1800	150	300	0	1.6

CALCULATION

2- OUTPUT DATA

The Selected Silencer is followed up with data sheet containing the following output calculations:

- Size, W/H/L
- Number of baffles
- Gap between baffles
- Output noise level
- Losses



Ref : FCU-1
Date: **/**/****

DUCT VENTILATION AIR CONDITIONING Co. (W.L.L.)

DVAC-Duct Ventilation Air Conditioning Co. Phone 974 44500118. Fax 974 44500117. www.dvac-duct.com

	63 Hz	125 Hz	250 Hz	500 Hz	1 kHz	2 kHz	4 kHz	8 kHz	Total
Source Noise In Duct SWL	88	87	87	82	81	79	71	63	93
Duct Area Correction dB	+1	+1	+1	+1	+1	+1	+1	+1	
In Duct SPL dB (Ref Only)	89	88	88	83	82	80	72	64	94
In Duct SWL dB	88	87	87	82	81	79	71	63	93
Silencer Insertion Loss (SWL) dB	9	14	21	28	32	24	19	16	
In Duct SWL after Silencer dB	79	73	66	54	49	55	52	47	80
Duct Area Correction dB	+1	+1	+1	+1	+1	+1	+1	+1	
In Duct SPL dB (Ref Only)	80	74	67	55	50	56	53	48	81
Correction for End Reflection	-5	-2	-0	-0	-0	-0	-0	-0	
Correction For Distance @ 10.5 metres	-28	-28	-28	-28	-28	-28	-28	-28	
Final SPL dB @ 10.5 metres	46	43	38	27	21	27	24	19	48
Silencer Regen Noise dB @ 10.5 metres	28	22	18	17	8	6	1	-6	30
Correction for 'A' Weighting	-26	-16	-9	-3	0	1	1	-1	
Final SPL dBA @ 10.5 metres	20	27	29	24	21	28	25	18	34

SWL = Sound Power Level dB re 10⁻¹² watts (picoWatts)
SPL = Sound Pressure Level dB re 2 X 10⁻⁵ N/M² (20 microPascals)
Sound levels are averages and do not include directivity factors
Distance corrections are free field using Hemispherical radiation.

Rectangular Silencer Style 2. Outer Body 1.6mm thick
Volume flow = 3040 L/S
Internal flange dimensions : 550mm x 1400mm x 1200mm Face to Face
550mm Wide x 1100mm Long Splitters. - 2 x side splitters 150mm Thick. 2 x Internal splitters 300mm Thick.
Side splitters are set inside the silencer by 150mm per side
External dimensions 1403.2mm x 553.2mm x 1200mm Long
Gap between splitters = 167mm. Air Velocity in the Gap = 11.0 m/s
Minimum Infill Density = 50 Kg/M³
LOSSES:
Friction Loss = 23.0 Pascals
Velocity pressure difference between the Gap Vp and Equipment Vp is 64.0 Pascals
The velocity pressure difference can be significant under certain applications

3- OUTPUT DATA

The Software issues a Sketch showing construction details.

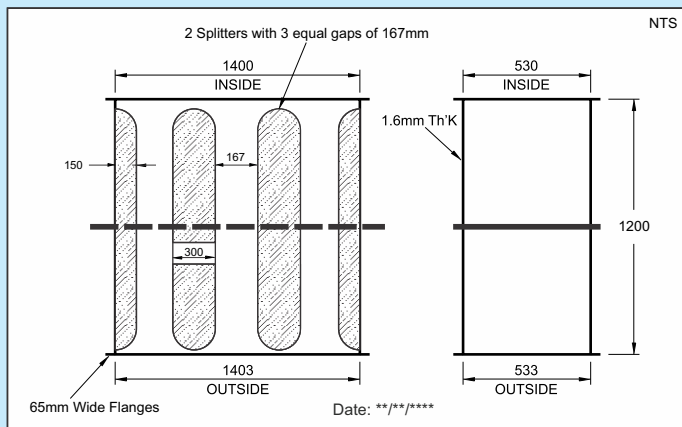

Sketch Of The Selected Silencer

Customer Selection Order

Order No.:

Date: / /

To : DVAC - Duct Ventilation Air Conditioning (W.L.L.)

Attn. : Engineering Department

Tel : +974 4500118 / 119

Fax : +974 4500117

Company Name : _____
 Contact Person : _____
 Project Name : _____
 Tel : _____
 Fax : _____

Item Reference	Qty	Duct Size			Volume Flow Rate	Distance Between Fan to 1st Grille (m)	Noise Level Desired dBA	Fan Static Pressure Pa	In Duct Sound Power Level												
		Width (mm)	Height (mm)	Diam. (mm)					CFM	L/S	63 Hz	125 Hz	250 Hz	500 Hz	1 k	2 k	4 k	8 k			

Notes : _____

 Signature :



Sound Attenuators SELECTION DATA

DUCT VENTILATION AIR CONDITIONING Co. (W.L.L.)

DOHA- QATAR - PHONE: +974-44500118 - +974-44500119 - FAX: +974-44500117

Customer Selection Order

Order No.:

Date: / /

To : DVAC - Duct Ventilation Air Conditioning (W.L.L)

Attn. : Engineering Department

Tel : +974 4500118 / 119

Fax : +974 4500117

Company Name :

Contact Person :

Project Name :

Tel :

Fax :

Item Reference	Qty	Duct Size			Volume Flow Rate		Distance Between Fan to 1st. Grille (m)	Noise Level Desired (dBA)	Fan Static Pressure (Pa)	In Duct Sound Pressure Level																			
		Width (mm)	Height (mm)	Diam. (mm)	CFM	L/S				63 Hz	125 Hz	250 Hz	500 Hz	1 k	2 k	4 k	8k	D (m)											

Notes : _____
Signature :

MAINTENANCE INSTRUCTIONS

1- DUCT SILENCERS INSTALLED INDOORS

Duct Silencers installed inside the buildings are designed to be essentially maintenance-free for the life of the product. The same method and routine used for periodic cleaning of the ducts will also apply to the duct silencers. The acoustic media used in the duct silencers is protected by the perforated metal liner so it will not erode during normal duct cleaning with vacuum equipment.

2- DUCT SILENCERS INSTALLED OUTDOORS

Silencers exposed to the outdoors should have all external joints and seams caulked with suitable sealant. Wherever possible, silencers should be shielded from exposure to moisture from rain or snow by providing suitable hoods, louvers or dampers. Occasional exposure of the silencers to moisture will not affect the longevity or the acoustical performance, provided that the water evaporates after exposure. If water is retained inside the silencer module casing or baffles, premature rusting may occur. To prevent this, drain holes should be provided in the silencer casing at all locations where water can collect. Duct silencers installed outdoors should be inspected at 6-month intervals. Silencers specified for outdoor locations require all seams to be caulked with mastic sealant for waterproofing, and all exposed welds to be coated with zinc-rich paint for rust proofing. Inspect the condition of the joints and replace loose or damaged sealant. Inspect the welds and casings for signs of rusting. Remove visible rust using a wire brush and re-coat with zinc-rich spray paint.

3- SILENCERS EXPOSED TO HIGH HUMIDITY

Silencers exposed to high humidity levels, such as those installed on cooling tower discharge fans, should be inspected frequently for signs of rusting. Remove visible rust using a wire brush and re-coat with zinc-rich spray paint. As a general rule, the lifetime of a silencer exposed to high humidity will be less than one installed in a dry Indoor location. Replacement of a silencer may be required at 10-year intervals or even sooner under more extreme conditions.

4- SILENCERS EXPOSED TO CORROSIVE ELEMENTS

Silencers specified for installation in locations where the outer casings will be exposed to high temperature or corrosive elements are typically constructed with corrosive-resistant materials or finished with corrosion-resistive coatings. Similarly, silencers that must convey high-temperature or corrosive gases will be constructed internally with non-corrosive materials. The required maintenance and expected lifetime of these products will vary. Consult the factory for specific maintenance information For silencers used in such applications.

CLEANING DUCT

1- WHY SHOULD OUR BUILDING AIR DUCTS BE CLEANED?

With the increasing global focus on environmental safety, building air quality has become very important. The growing number of lawsuits is an indication of this problem. Poor air quality is proven to affect the health of workers everywhere.

According to environmental experts nationwide, many building air problems begin in the ducts.

Carbon-containing dirt and moisture found in building ductwork And air-conditioning drip pans breed bacteria and mold.

These contaminants float throughout the air handling system In the building. The first and least expensive step to eliminating these problems is to clean the building air handling system.

2- WHY SHOULD WE CLEAN OUR DUCTWORK?

- Human Health Concerns, Energy Management and Indoor Environmental concerns will be addressed.
- Allergy & Asthma sufferers can be helped.
- Indoor cleaning can be reduced
- Remove unwanted indoor pollutants; mold, fungus, bacteria and mites.

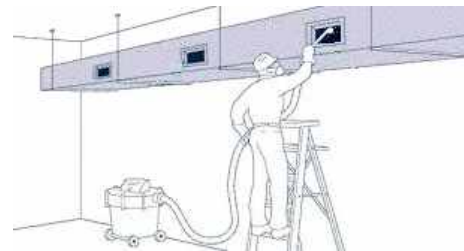

Air Outlet Cleaning

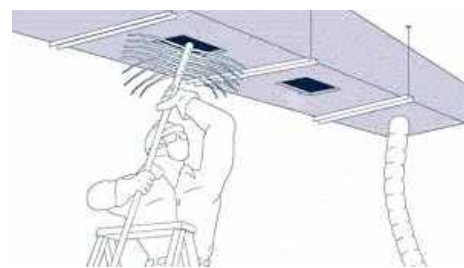

Duct Cleaning

DVAC

DUCT VENTILATION AIR CONDITIONING Co. (W.L.L.)

*Small Industries Zone - Pink Area
Zone 81 - Street 13 - Bldg. 57*

Tel: +974 445 00 118 - 445 00 119

Fax: +974 445 00 117

P.O. Box: 55619 - Doha, State Of Qatar

Email: info@dvac-duct.com

Website: www.dvac-duct.com