

MODEL TDD

DIRECT DRIVE TUBEAXIAL DUCT FAN



MODEL FEATURES

- Rated up to 39,000 CFM in static pressure applications up to 1-1/4" w.g.
- Direct drive units have low sound levels and quiet operation
- Smaller sizes for areas with reduced airflow needs
- Require practically no maintenance
- AMCA Air Licensed

MODEL OVERVIEW

S&P's tubeaxial line offers the widest range of sizes, horsepower and performance in the industry. Models TDD are high capacity tubeaxial fans rated from 800 to 39,000 CFM, with static pressure capability up to 1-1/4". They are used to exhaust air from or supply air to such typical commercial and industrial applications as general building ventilation, enclosed garages, paint spray booths, heat and smoke ventilation systems and other applications where air is moved through a duct system against moderate static pressure.

Direct drive Models TDD are best used for exhausting or supplying relatively clean ambient temperature air. They are available in smaller sizes for areas with reduced airflow needs and require practically no maintenance.

CONSTRUCTION FEATURES AND OPTIONS

Mounting Supports
Eight (8) mounting supports are welded to each fan to allow for universal mounting.

Propeller
Polypropylene and aluminum propellers are selected for maximum airflow and low sound.

Factory Run & Tested
For quality assurance and dependable operation.

cULus 705 Listed
For electrical reliability. us

ACMA Seal
Assures rating of Air Performance.

Integral Inlet and Outlet Flanges
With mounting holes.

Motor
National brands with local service. Standard motors are heavy-duty open drip-proof. Other options available.

Housing
Heavy-gauge rolled galvanized steel with continuous welded seam and epoxy coating for maximum strength.

2 year fan housing warranty, 1 year motor warranty



CONSTRUCTION/SPECIFICATION CHECKLIST

Fan Housing

- Heavy-gauge rolled galvanized steel construction.
- Integral inlet and outlet flanges with mounting holes.
- Continuous welded and epoxy coated.
- Eight mounting supports welded to each fan.
- Rolled steel flange reinforcement on each end.

Propeller (Sizes 12 - 18)

- Polypropylene blades.
- Steel bushing.
- Blades are pitched for optimum efficiency.
- Statically and dynamically balanced.
- Aluminum blades are optional (by special quote only).

Propeller (Sizes 20-48)

- Three, five or six wing airfoil aluminum blades.
- Steel or aluminum hub plate with steel bushing.
- Blades are pitched for optimum efficiency.
- Statically and dynamically balanced.
- Polypropylene blades are optional (by special quote only).

Motors

- One year motor warranty.
- Brands are nationally recognized and locally serviced.
- Open drip-proof construction is standard.
- Premium-efficiency, explosion proof, totally enclosed fan cooled (TEFC) and corrosion duty motors can be specified.

Certifications

- cULus 705 Listed.
- AMCA Air Licensed.

Entire Fan Unit

- Factory assembled and tested prior to shipment for quality assurance.



OPTIONS/ACCESSORIES

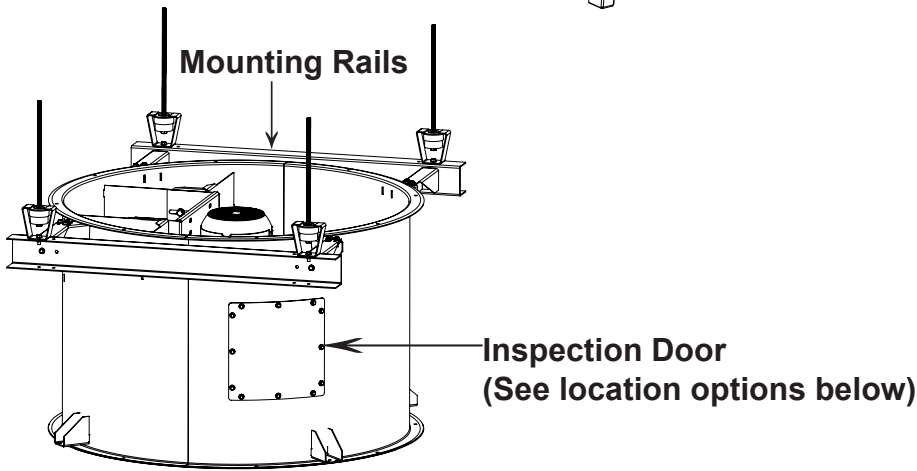
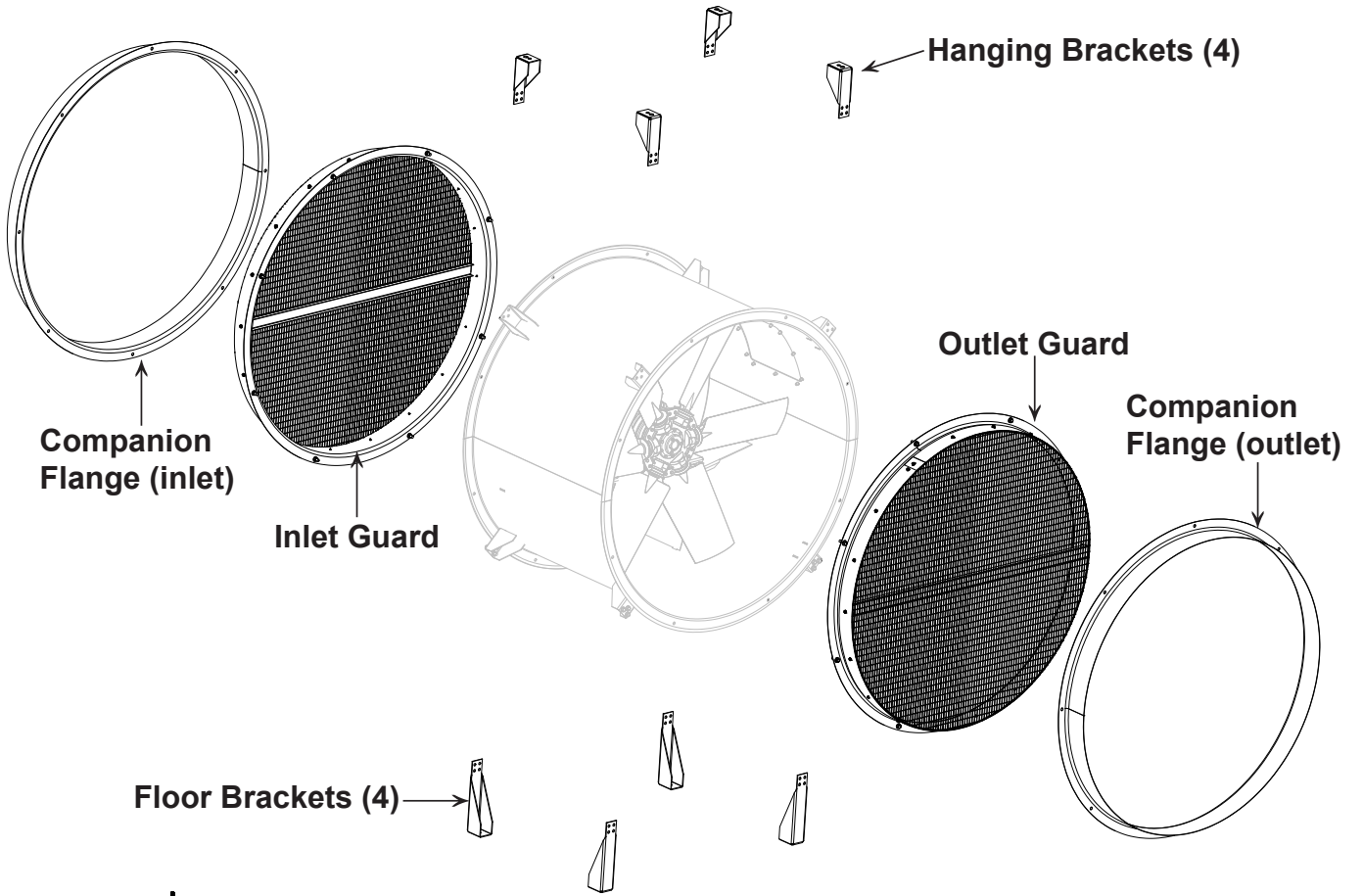

Inspection Door Location Options

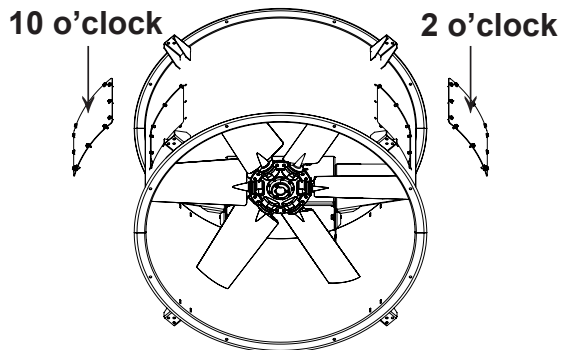

Floor or Hanging Isolator Options

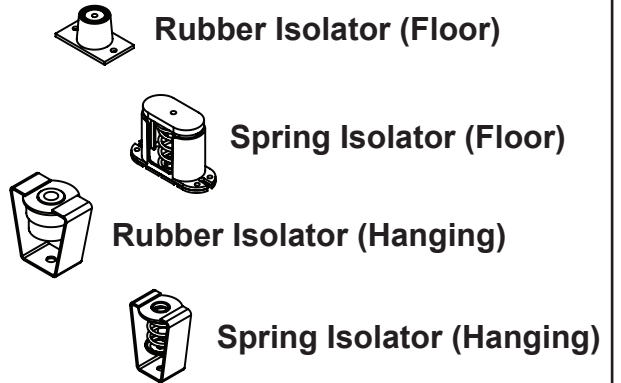



OPTIONS/ACCESSORIES

Hanging & Floor Brackets: For base or ceiling mounting. Neoprene and spring isolators are available.

Mounting Rails: Designed for vertical and horizontal mounting. Rail kits include mounting brackets. Vertical mounting available by special quote on sizes 34-48”.

Inlet/Outlet Guard: Prevents objects from entering the fan inlet or outlet. Includes companion flange.

Inspection Door: For inspection and blade service/cleaning. Bolted. Not available on sizes 12 and 16.

Companion Flanges: Inlet and/or outlet flanges are available for duct connection.

Disconnect Switch: Nonfused safety disconnect available for all motor sizes and enclosures. Specify prewired if desired. (Wiring not available on explosion proof and two speed motors).

Special Coatings (*Epoxy Coating is Standard*): For protective and decorative purposes. Available coatings include: Synthetic Resin and Heresite (air-dried phenolic). Contact your representative or the factory for more information on available coatings and colors.

MOUNTING CONFIGURATIONS

Floor Mount

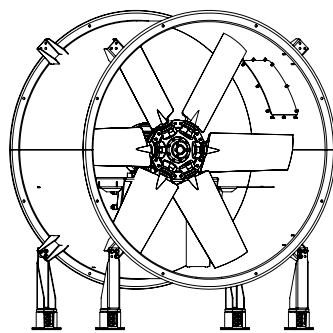

Hanging Mount

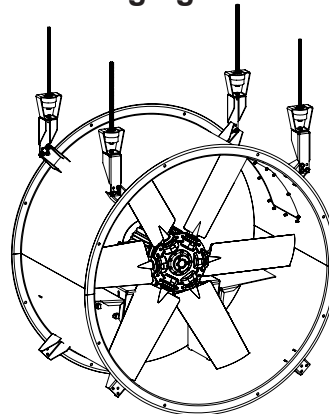

Vertical Rail Floor Mount

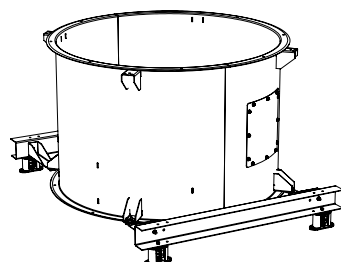

Vertical Rail Hanging Mount

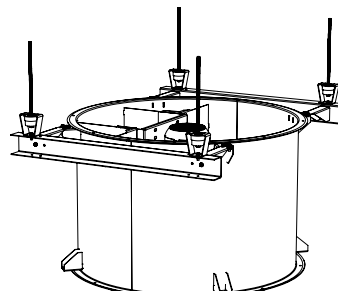

Vertical mounting available on special quote on sizes 34-48”.

Note: The 12 & 16 are designed to mount to a supported duct work and do not have all mounting configurations.



PERFORMANCE & DIMENSIONS

Sizes 12 and 16

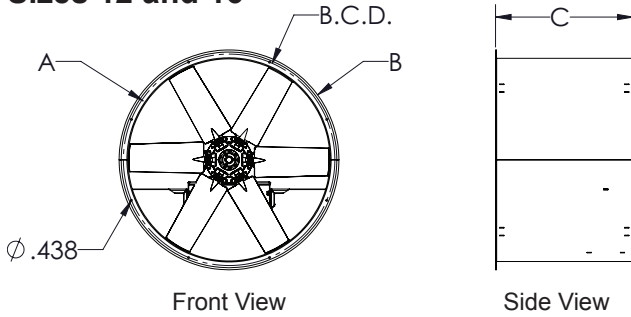

	12	16	18	20	24
Max. Motor Frame:	56	56	145T	145T	213T
Housing Gauge:	16	16	14	14	12
Approx. Weight:	90	108	150	178	273
Flange Holes:	6	8	8	8	8
Diameter Flange Holes:	7/16"				
Finish:	Epoxy Coated Galvanized				

Size	A	B	C*	B.C.D.
12	12-3/8	15	12	13-1/2
16	16-3/8	18-7/8	16-1/2	17-3/8
18	18-3/8	22-1/2	22	19-3/4
20	20-3/8	24-1/2	22	21-3/4
24	24-3/8	28-5/8	23	25-3/4

A: ID B: OD C: Length (*motor may extend past unit)

Sizes 18, 20 and 24

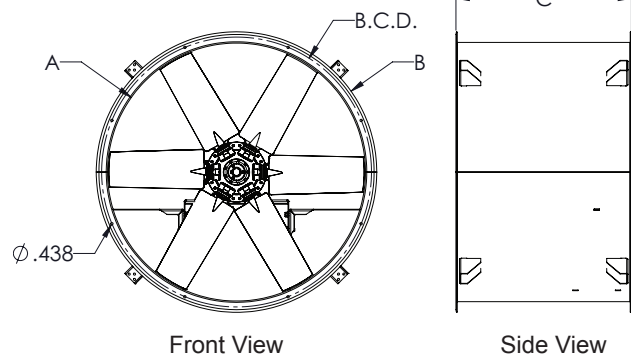

Model	HP	Nominal RPM	Max Watts	Static Pressure (Inches W.G.)									Sones @ 5 ft		
				0	0.125	0.25	0.375	0.5	0.625	0.75	0.875	1		1.25	
				CFM											
12	1/4	1140	200	855	-	-	-	-	-	-	-	-	-	-	15.9
	1/4	1725	210	1330	1215	-	-	-	-	-	-	-	-	-	17
	1/3	1725	275	1545	1420	-	-	-	-	-	-	-	-	-	17
16	1/3	1140	218	2220	1965	-	-	-	-	-	-	-	-	-	16.1
	1/2	1725	415	3000	2805	2551	2207	-	-	-	-	-	-	-	19.5
	3/4	1725	615	3341	3200	3024	2801	2445	-	-	-	-	-	-	22.4
18	1/3	1140	260	3160	2715	-	-	-	-	-	-	-	-	-	16.3
	1/2	1140	355	3500	3191	2667	-	-	-	-	-	-	-	-	17.8
	1	1725	742	4709	4458	4167	3790	3305	-	-	-	-	-	-	22.6
	1-1/2	1725	1025	5326	5147	4950	4703	4364	3875	-	-	-	-	-	25.1
20	1/4	1725	185	1713	1249	733	-	-	-	-	-	-	-	-	23
	1/3	1725	251	1835	1578	1281	990	726	-	-	-	-	-	-	29.3
	1/2	1725	351	2451	2208	1915	1584	1275	1002	752	-	-	-	-	28.2
	3/4	1725	603	4469	4160	3818	3423	2775	-	-	-	-	-	-	23.2
	1	1725	805	4877	4611	4361	3995	3487	2617	-	-	-	-	-	24.2
24	1/4	1140	219	2777	-	-	-	-	-	-	-	-	-	-	17.5
	1/3	1140	278	4711	3876	-	-	-	-	-	-	-	-	-	18.1
	3/4	1140	620	6562	5996	5312	3583	-	-	-	-	-	-	-	21.5
	1-1/2	1725	1155	7812	7304	6775	6084	5013	3777	-	-	-	-	-	25.9
	2	1725	1273	8967	-	-	-	-	-	-	-	-	-	-	32.3
	3	1725	2536	9982	9659	9324	8951	8481	7980	6674	4395	3383	-	31.3	

Performance certified is for installation type A: free inlet, free outlet. Performance ratings do not include the effects of appurtenances (accessories). The AMCA Certified Ratings Seal applies to air performance ratings only. Speed (rpm or rps) shown is nominal. Performance is based on actual speed of test.

Sound data is calculated and should be used as a guideline only.



S&P USA Ventilation Systems, LLC., Div. of Soler & Palau Ventilation Group certifies that the Models TDD shown herein are licensed to bear the AMCA Seal. The ratings shown are based on test and procedures performed in accordance with AMCA Publication 211 and comply with the requirement of the AMCA Certified Ratings Program.





MODEL TDD
DIRECT DRIVE TUBEAXIAL DUCT FAN



Sizes 30, 34 and 36

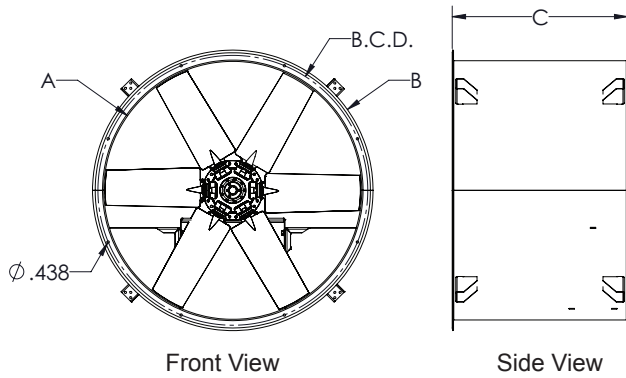

Max. Motor Frame: 215T
Housing Gauge: 30" & 34" = 12
 36" = 10
Approximate Weight: 30" = 320 lbs.
 34" = 457 lbs
 36" = 532 lbs.
Flange Holes: 8
Diameter Flange Holes: 7/16"
Finish: Epoxy Coated Galvanized

Size	A	B	C*	B.C.D.
30	30-3/8	34-5/8	24	32
34	34-3/8	38-5/8	27	36-3/8
36	36-3/8	40-5/8	29	38

A: ID B: OD C: Length (*motor may extend past unit)

Model	HP	Nominal RPM	Max Watts	Static Pressure (Inches W.G.)										Sones @ 5 ft	
				0	0.125	0.25	0.375	0.5	0.625	0.75	0.875	1	1.25		
				CFM											
30	1/2	870	336	6319	5167	3296	-	-	-	-	-	-	-	-	19.4
	3/4	870	595	8990	7855	6280	3212	-	-	-	-	-	-	-	19.9
	1	870	797	9468	8661	7819	6771	5360	3234	-	-	-	-	-	20.5
	3/4	1140	551	8385	7534	6540	5448	4011	2159	-	-	-	-	-	24.4
	1	1140	832	10585	9743	8827	7746	6359	-	-	-	-	-	-	21.9
	1-1/2	1140	1313	11098	10452	9735	8984	8143	6777	5128	3758	2619	-	-	25.7
	2	1140	1750	13541	12564	11525	10230	8375	6456	-	-	-	-	-	26.2
	3	1725	2319	15937	15385	14804	14223	13662	13060	12382	11695	10903	8911	-	35.1
34	1	870	803	11681	10459	9210	7659	4988	-	-	-	-	-	-	26.5
	2	870	1540	15841	14547	12937	10715	6852	-	-	-	-	-	-	27.3
	3	870	2281	16850	15391	13589	11557	9249	7712	6359	4513	-	-	-	28.8
	1	1140	700	10873	9714	8535	7155	5418	-	-	-	-	-	-	32.7
	1-1/2	1140	1180	14766	13747	12470	10984	9415	7236	-	-	-	-	-	33.3
	2	1140	1643	15466	14775	14072	13295	12520	11585	10508	9005	7305	-	-	33.6
	3	1140	2211	15781	15184	14448	13650	12866	11863	10883	9536	7838	-	-	34.3
	3	1725	1641	14231	13414	12646	11985	11211	10502	9634	8675	7677	5126	-	40.3
36	5	1725	3742	20532	19726	19003	18243	17341	16590	15783	14907	13951	-	-	44.8
	7-1/2	1725	5910	25386	24606	23903	23253	22346	21572	20616	19657	18769	-	-	47.3
	10	1725	7640	27099	26381	25610	24747	23841	22917	21981	-	-	-	-	44.8
	1/2	870	388	8768	6696	4555	-	-	-	-	-	-	-	-	39.8
	3/4	870	623	9599	8489	7315	5885	4180	-	-	-	-	-	-	40
	1	870	777	12145	11036	9590	7834	4689	-	-	-	-	-	-	38.9
	2	870	1506	16923	15640	14138	12527	-	-	-	-	-	-	-	38.1
	3	870	2190	19939	18710	17270	15332	-	-	-	-	-	-	-	39.6
36	1	1140	734	9845	8814	7898	6881	5692	4415	3162	-	-	-	-	47.9
	1-1/2	1140	1233	13912	13020	12080	11053	9977	8644	7052	-	-	-	-	44
	2	1140	1605	16118	15216	14206	13311	12265	11058	-	-	-	-	-	44.2
	3	1140	2357	19585	18583	17641	16720	15723	14450	12497	-	-	-	-	43.8
	5	1140	3585	23209	22247	21168	20193	19062	17740	16319	-	-	-	-	45.7
	5	1725	3774	22503	21681	20924	20030	19290	18590	17608	16516	15362	-	-	77.8
	7-1/2	1725	5482	27426	26625	25742	24940	24009	23336	22403	21632	20529	17741	-	83.8
	10	1725	7734	27645	27396	26953	26496	26020	25526	25108	24665	24191	23029	-	85.8

Performance certified is for installation type A: free inlet, free outlet. Performance ratings do not include the effects of appurtenances (accessories). The AMCA Certified Ratings Seal applies to air performance ratings only. Speed (rpm or rps) shown is nominal. Performance is based on actual speed of test.

Sound data is calculated and should be used as a guideline only.



S&P USA Ventilation Systems, LLC., Div. of Soler & Palau Ventilation Group certifies that the Models TDD shown herein are licensed to bear the AMCA Seal. The ratings shown are based on test and procedures performed in accordance with AMCA Publication 211 and comply with the requirement of the AMCA Certified Ratings Program.





MODEL TDD
DIRECT DRIVE TUBEAXIAL DUCT FAN



Sizes 42 and 48

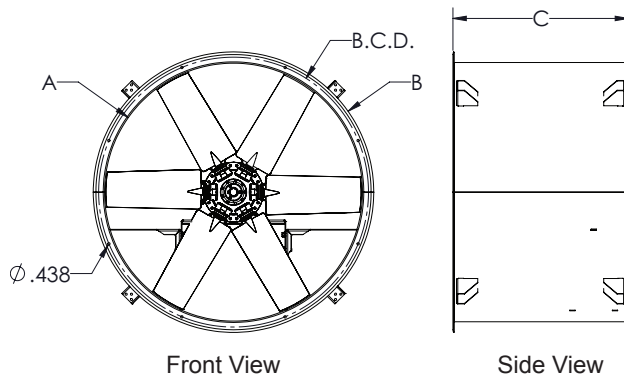

Max. Motor Frame: 256T
Housing Gauge: 10
Approximate Weight: 42" = 738 lbs.
 48" = 834 lbs.
Flange Holes: 8
Diameter Flange Holes: 7/16"
Finish: Epoxy Coated Galvanized

Size	A	B	C*	B.C.D
42	42-1/2	46-3/4	30	44-1/4
48	48-1/2	52-3/4	33	50-3/4

A: ID B: OD C: Length (*motor may extend past unit)

Model	HP	Nominal RPM	Max Watts	Static Pressure (Inches W.G.)										Sones @ 5 ft	
				0	0.125	0.25	0.375	0.5	0.625	0.75	0.875	1	1.25		
				CFM											
42	1	870	827	14852	13115	11297	-	-	-	-	-	-	-	-	51.6
	1-1/2	870	1052	16770	14891	12732	9764	-	-	-	-	-	-	-	47.9
	2	870	1465	19453	17432	15438	13232	-	-	-	-	-	-	-	45.4
	3	870	2285	23340	21467	19524	14841	-	-	-	-	-	-	-	48.6
	5	870	3549	28037	25801	23523	20105	15400	-	-	-	-	-	-	48.9
	1-1/2	1140	1144	15712	14284	12308	10623	8050	5282	-	-	-	-	-	46.5
	2	1140	1674	18673	17304	15722	13733	11550	8942	5461	-	-	-	-	48.7
	3	1140	2376	22901	21599	20463	18932	17728	16082	-	-	-	-	-	53.6
	5	1140	3856	26764	25256	23923	22351	20815	18986	15351	-	-	-	-	50.3
	7-1/2	1140	6044	33612	32257	30801	29238	27936	26242	-	-	-	-	-	51.9
48	10	1140	7971	33813	32945	32039	31300	30495	29740	28839	27980	27160	24777	52.3	
	2	870	1560	21749	19771	17626	15403	12476	9330	-	-	-	-	92.4	
	3	870	2417	26784	24879	22874	20641	17950	14239	-	-	-	-	55.4	
	5	870	4034	29978	28722	27401	26053	24747	23134	21353	19038	-	-	53.4	
	7-1/2	1140	6205	33555	32536	31630	30588	29507	28681	27606	26875	25782	-	92.4	
	10	1140	8560	40194	39319	38344	37469	36576	35415	34256	33130	32324	-	95	

Performance certified is for installation type A: free inlet, free outlet. Performance ratings do not include the effects of appurtenances (accessories). The AMCA Certified Ratings Seal applies to air performance ratings only. Speed (rpm or rps) shown is nominal. Performance is based on actual speed of test.

Sound data is calculated and should be used as a guideline only.



S&P USA Ventilation Systems, LLC., Div. of Soler & Palau Ventilation Group certifies that the Models TDD shown herein are licensed to bear the AMCA Seal. The ratings shown are based on test and procedures performed in accordance with AMCA Publication 211 and comply with the requirement of the AMCA Certified Ratings Program.



Standard 705