

SPECIFICATIONS

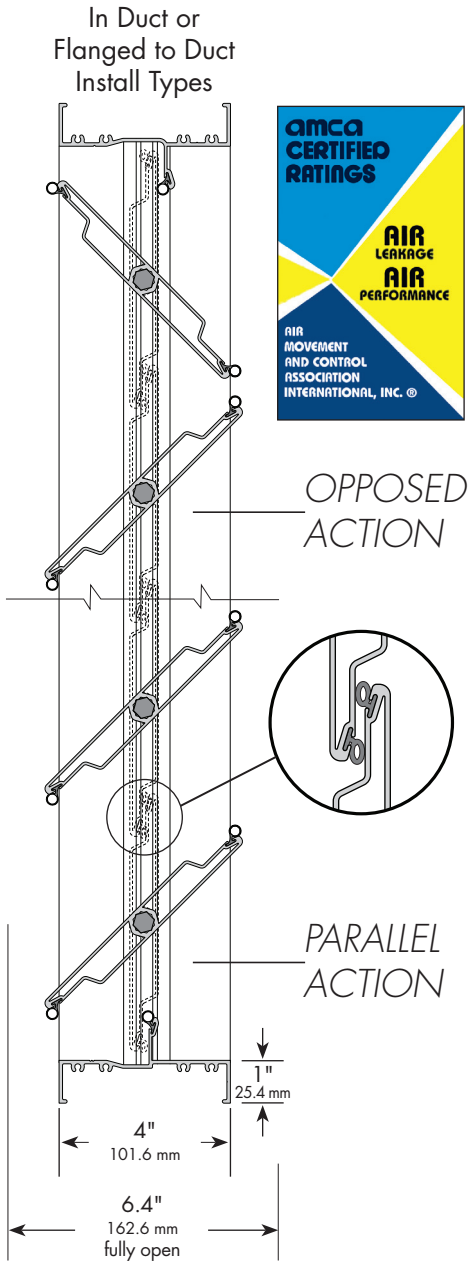

S E R I E S 2 1 0 0

CONTROL DAMPER

1. Extruded aluminum (6063-T5) damper frame is not less than 0.080" (2.03 mm) in thickness. Damper frame is 4" (101.6 mm) deep x 1" (25.4 mm), with mounting flanges on both sides of frame. Damper frame has a 2" (50.8 mm) mounting flange on the rear of the damper, when ordered as Extended Rear Flange install type.
2. Blades are extruded aluminum (6063-T5) air-foil profiles.
3. Blade and frame seals are extruded silicone, secured in an integral slot within the aluminum extrusions. Seals are mechanically fastened to prevent shrinkage and movement over the life of the damper.
4. Bearings are composed of a Celcon inner bearing (fixed around a 7/16" (11.11 mm) aluminum hexagon blade pivot pin) rotating within a polycarbonate outer bearing inserted in the frame. This eliminates action between metal-to-metal or metal-to-plastic riding surfaces.
5. Adjustable 7/16" (11.11 mm) hexagonal drive rod, U-bolt fastener, and hexagonal retaining nuts are zinc-plated steel. These provide a positive connection to blades and linkage.
6. Aluminum and corrosion-resistant zinc-plated steel linkage hardware is installed in the frame side, complete with stainless steel trunnions and cup-point trunnion screws for a slip-proof grip.
7. Dampers are designed for operation in temperatures ranging from -40°F (-40°C) to 212°F (100°C).
8. Leakage Class 1A at 1 in w.g. (0.25 kPa) static pressure differential. Standard air leakage data is certified under the AMCA Certified Ratings Program.
9. Dampers are custom made to required size, without blanking off free area.
10. Dampers are available with either opposed blade action or parallel blade action.
11. Dampers are available in three install types: i.e., Installed in Duct, Flanged to Duct, or Extended Rear Flange. (See page 3 for details)
12. Installation of dampers must be in accordance with TAMCO's current installation guidelines, provided with each damper shipment. (Note that all technical information available on TAMCO's web site at www.tamcodampers.com supersedes and takes precedence over all information contained within the printed catalog.)
13. Intermediate structural support is required to resist applied pressure loads for dampers that consist of two or more sections in both height and width. (See TAMCO Aluminum Damper Installation Guidelines.)

OPTION (For each option listed, replace the specification lines above with their corresponding specification lines below.)

SW - SALT WATER RESISTANCE OPTION:

1. Extruded aluminum (6063-T5) damper frame is not less than 0.080" (2.03 mm) in thickness. Damper frame is 4" (101.6 mm) deep x 1" (25.4 mm), with mounting flanges on both sides of frame. Damper frame has a 2" (50.8 mm) mounting flange on the rear of the damper when ordered as Extended Rear Flange install type. Aluminum frame is clear anodized to a minimum thickness of 0.7 mil (18 microns) deep. Frame is assembled using stainless steel screws.
2. Blades are extruded aluminum (6063-T5) air-foil profiles, clear anodized to a minimum thickness of 0.7 mil (18 microns) deep.
5. Adjustable 7/16" (11.11 mm) hexagonal drive rod, U-bolt fastener, and hexagonal retaining nuts are stainless steel. These provide a positive connection to blades and linkage.
6. Linkage hardware is installed in the frame side. All aluminum linkage hardware parts are clear anodized. All non-aluminum linkage hardware parts are stainless steel. They are complete with cup-point trunnion screws for slip-proof grip.

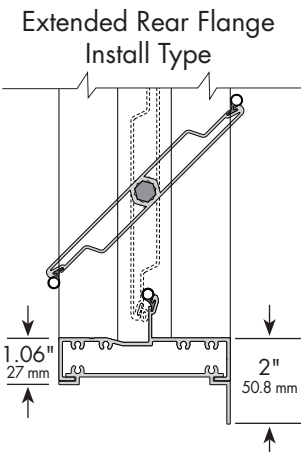

TAMCO Series 2100 Control Dampers are sold exclusively by Ebtron, Inc.
This product is not available in Minnesota, Wisconsin, or in Canada.

PERFORMANCE DATA

S E R I E S 2 1 0 0 CONTROL DAMPER



T.A. Morrison & Co. Inc. certifies that the TAMCO Series 2100 Control Damper shown herein is licensed to bear the AMCA Seal. The ratings shown are based on tests and procedures performed in accordance with AMCA Publication 511 and comply with the requirements of the AMCA Certified Ratings Program. The AMCA Certified Ratings Seal applies to air leakage and air performance ratings.

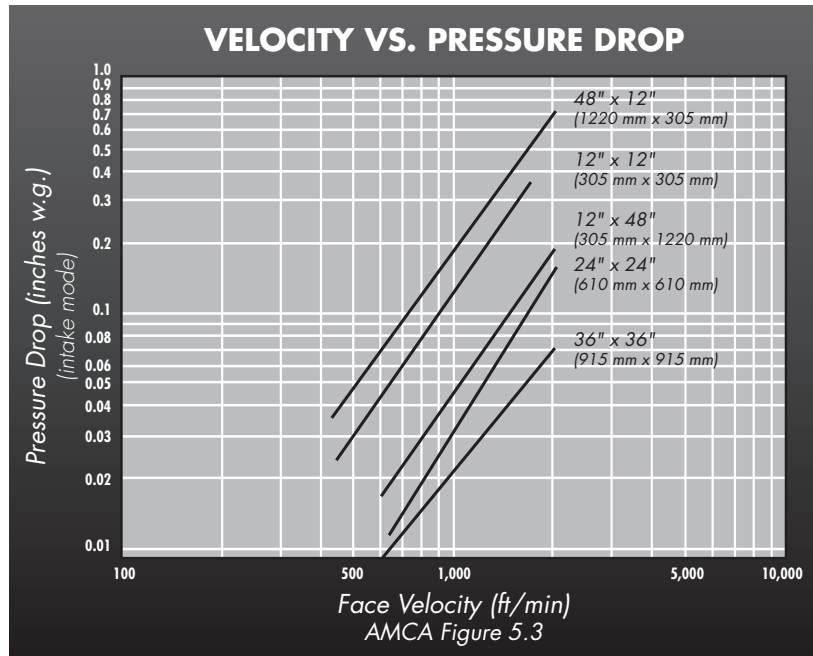

TAMCO LEAKAGE CLASS RATING

Damper Width inches (mm)	1 in. w.g. 0.25 kPa	4 in. w.g. 1.0 kPa	6 in. w.g. 1.5 kPa	8 in. w.g. 2.0 kPa
0.0 to 12.0 (0 - 305)	1A	1	1	1
12.1 to 36.0 (306 to 915)	1A	1	1	1
36.1 to 48.0 (916 to 1220)	1A	1	n/a*	n/a*
48.1 to 60.0 (1221 to 1524)	1A	1	n/a*	n/a*

*NOTE: TAMCO Leakage Class Rating is not provided for dampers measuring more than 36" (915 mm) wide at 6 in. w.g. (1.5 kPa) and at 8 in. w.g. (2.0 kPa), as the recommended blade length is exceeded at these static pressures. (Refer to the Blade Design Pressure Limitations Chart.)

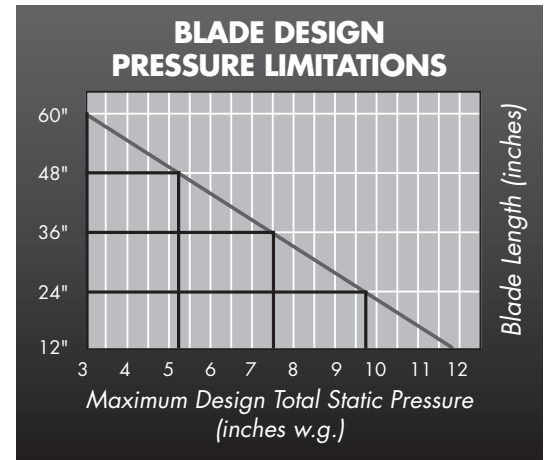

TAMCO Series 2100 Control Dampers, whose blade length exceeds the maximum design pressure, may be reconfigured to maintain a blade length compatible with the required system pressure by increasing the number of sections per damper and thereby reducing each damper section's blade length. Appropriate intermediate structural support will be required for all multiple-section damper assemblies. (Refer to line 13 in the specifications on page 1 and to TAMCO's Aluminum Damper Installation Guidelines.)

Example: 1 section damper of 60" w x 36" h (1524 mm x 915 mm) at 5 in. w.g. (1.24 kPa) would need to be built in 2 sections of 30" w x 36" h (762 mm x 915 mm).

AMCA LEAKAGE CLASS DEFINITIONS

Pressure / Class	MAXIMUM LEAKAGE CFM/ft ² (l/s/m ²)			
	1 in. w.g. 0.25 kPa	4 in. w.g. 1.0 kPa	6 in. w.g. 1.5 kPa	8 in. w.g. 2.0 kPa
1A	3 (15.2)	n/a	n/a	n/a
1	4 (20.3)	8 (40.6)	9.8 (49.0)	11.3 (56.6)
2	10 (50.8)	20 (102)	24.5 (125)	28.3 (288)
3	40 (203)	80 (406)	98 (497)	113 (574)

Leakage testing was conducted in accordance with AMCA Standard 500-D. Data are based on a torque of 60 in-lbs (73.0 N-m/m²) for a 12" x 48" damper and 84 in-lbs (102.2 N-m/m²) for a 48" x 36" and a 60" x 36" damper. AMCA Standard 500-D states that air leakage is based on operation between 32°F (0°C) and 120°F (49°C).

The following sizes of TAMCO Series 2100 Dampers were tested:
12" x 48" (305 mm x 1220 mm), 48" x 36" (1220 mm x 915 mm), 60" x 36" (1524 mm x 915 mm).

INSTALL TYPES

S E R I E S 2 1 0 0 CONTROL DAMPER

Always provide opening width and height dimensions, when ordering.

Width dimension is always parallel to blades.

Height dimension is always perpendicular to blades.

INSTALLED IN DUCT TYPE

Finished damper O.D. is ½" (12.7 mm) less than opening width & height dimensions.

Minimum section size:	6½" w x 6¾" h	(166 mm x 172 mm)
Maximum section size:	25 ft²	(2.3 m²)
	60" w x 60" h or	(1524 mm x 1524 mm) or
	48" w x 75" h	(1220 mm x 1905 mm)



FLANGED TO DUCT TYPE

Finished damper O.D. is 2" (50.8 mm) greater than opening width & height dimensions

Minimum section size:	4½" w x 4¼" h	(115 mm x 108 mm)
Maximum section size:	25 ft²	(2.3 m²)
	60" w x 60" h or	(1524 mm x 1524 mm) or
	48" w x 75" h	(1220 mm x 1905 mm)

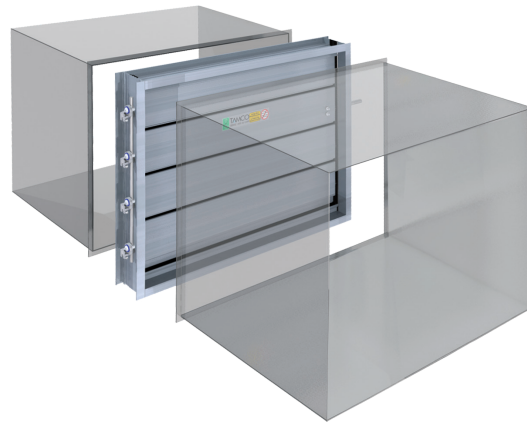

EXTENDED REAR FLANGE TYPE

Finished damper O.D. is 4" (101.6 mm) greater than opening width & height dimensions

Minimum section size:	4½" w x 4¼" h	(115 mm x 108 mm)
Maximum section size:	25 ft²	(2.3 m²)
	60" w x 60" h or	(1524 mm x 1524 mm) or
	48" w x 75" h	(1220 mm x 1905 mm)

Extended Rear Flange install type dampers are not designed so that the front of the damper may be inserted into an opening, as the side frame members extend to the full height of the rear flange.



See Page 4 for Square to Round Transition Install Type

INSTALL TYPES

S E R I E S 2 1 0 0 CONTROL DAMPER

Always provide duct diameter dimension when ordering.
If using TAMCO Connect software to submit orders, enter diameter dimension in both the width and height fields.

SQUARE TO ROUND TRANSITION

- Transition pieces are a minimum of 18 ga. galvanized steel for Series 2100 dampers, when ordered as standard.
- Transition pieces are 304 stainless steel, when Series 2100 dampers are ordered with the SW Option.
- Transition pieces and damper are sealed together.
- Dampers are built 4" (102 mm) larger than specified duct diameter. (Dampers are fabricated square.)
- Finished transition diameter is 1/4" (6.35 mm) less than specified duct diameter, providing clearance for mating duct which slides over round transition. This ensures free movement of damper blades.
- Minimum duct diameter: 4" (102 mm)
Maximum duct diameter: 58" (1474 mm)
Maximum section size: 25 ft² (2.3 m²)
Maximum finished OD: 62" w x 62" h (1575 mm x 1575 mm)

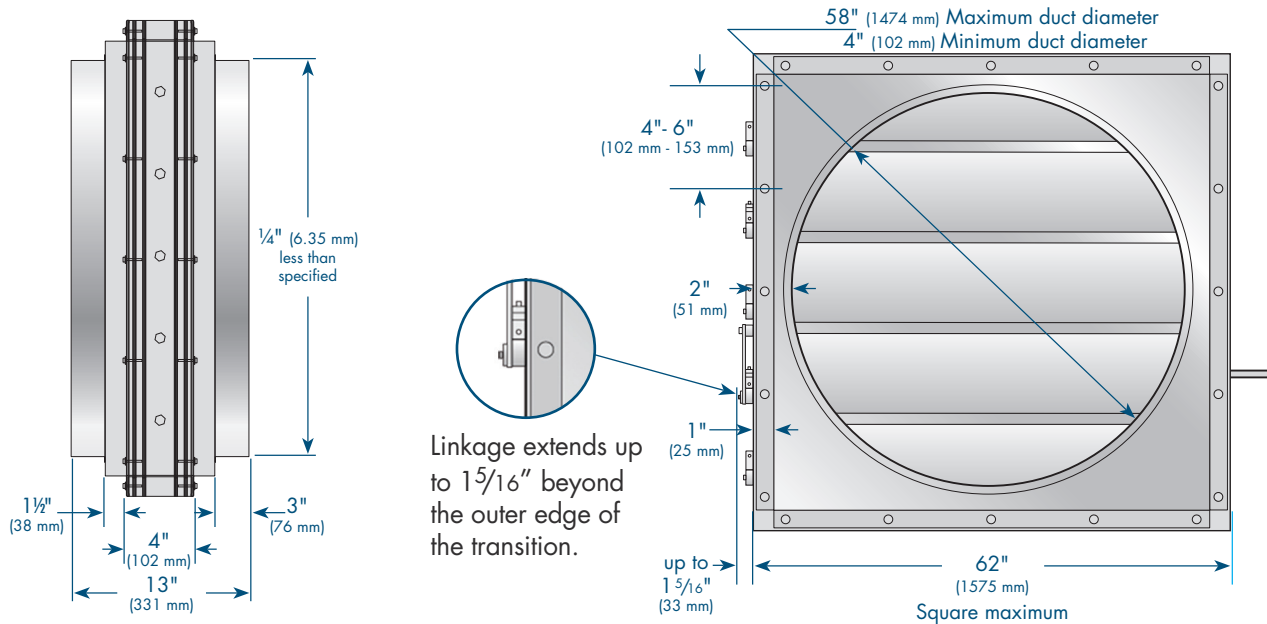

Note:

- To reduce pressure drop, use Flanged to Duct mount type for sizes under 9 ft² (.83 m²).
- Suitable for operation in breathable air environments within stated temperature range.
- Dampers sized for duct openings exceeding 37 1/2" (953 mm) in height are equipped with a stiffener bar at mid-height to strengthen and maintain air leakage tolerances.

For additional information, refer to:

- Aluminum Damper Standard Configurations
- Aluminum Damper Torque Requirements
- Multiple-Section Horizontal Jack Shafts
- Configurations Using Vertical Jack Shafts
- Multiple-Section Damper Jumpers
- TAMCO Aluminum Damper Installation Guidelines