

# Mixed Flow Inline Fan Models EQD and EQB

Direct and Belt Drive

- High Efficiency
- Lower Cost
- Low Sound



BUILDING VALUE IN AIR.

 **GREENHECK**  
Building Value in Air.

December  
2017



## EQD & EQB mixed flow inline fans

are designed to efficiently exhaust, supply, or recirculate general clean air in a building.

Utilizing a patent-pending **octagonal** housing, the compact yet **rugged** design of the fans maximizes air performance while **reducing energy** usage and **sound**.

### Typical Installations

- Manufacturing
- Multifamily
- Office buildings
- Educational facilities
- Hospitals
- Concert halls
- Libraries
- Parking garages

### Model Benefits

- Less expensive than traditional mixed flow inline fans
- More efficient and quieter operation than comparably sized centrifugal and axial fans
- Available with shorter lead times than tubular inline fans
- Easy to install and maintain
- Vari-Green® motor option on EQD

---

## Table of Contents

Features .....	4-5	Model Number Code .....	14
Options & Accessories .....	6-8	Performance .....	15-28
Design and Performance .....	9-10	Specifications .....	29-30
Mounting Configurations .....	11-13	EQB Cost Comparison .....	31
Typical Installation .....	14		

# Models EQD and EQB Mixed Flow Inline Fan



Model Comparison																									
Model	Location		Mounting					Airflow				Application						Drive Type		Impeller Type			Performance		
	Outdoor	Indoor	Roof Curb	Base/Floor	Hanging	Wall	Ceiling Mounted	Exhaust	Supply	Reversible	Recirculate	General/Clean Air	Contaminated Air	Spark Resistant	Grease (UL 762)	Smoke Control (UL)	High Wind (150 mph)	High Temp (above 200°F)	Belt	Direct	Centrifugal	Propeller/Axial	Mixed Flow	Maximum Volume (cfm)	Maximum Static Pressure (in. wg)
EQD		✓		✓	✓	✓	✓	✓	✓		✓	✓							✓				✓	4,300	2.5
EQB		✓		✓	✓			✓	✓		✓	✓						✓					✓	23,000	3

The unique combination of installation flexibility, rugged construction, and efficient air performance, make models EQD and EQB the ideal selection for any clean air application.

- Broad performance range, up to 3 in. wg (747 Pa) and 23,000 cfm (39,077 m<sup>3</sup>/hr).
- Performance as cataloged is assured. All fan sizes are tested in our AMCA Accredited Laboratory and all models are licensed to bear the AMCA Sound and Air Performance seal.
- UL/cUL Listed for Electrical.
- Models EQD and EQB fans are subjected to extensive life testing to assure the fans will provide many years of reliable performance.
- Each fan is tested at the factory prior to shipping. The test includes a quality check, RPM adjustment and maximum amp draw check.
- Each fan displays a permanently stamped metal nameplate with complete model number, mark and unique serial number for identification.

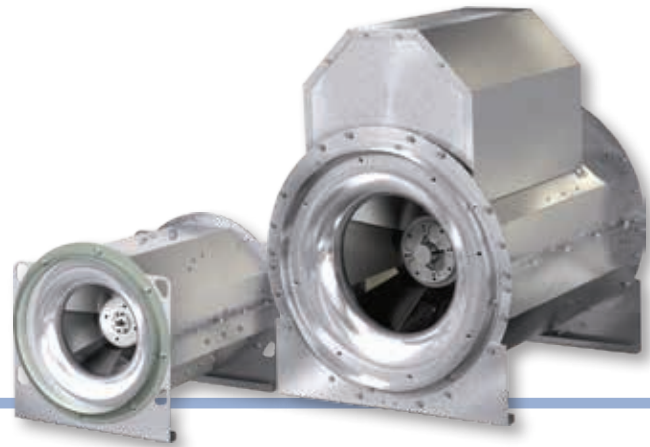

Greenheck Fan Corporation certifies the model EQD and EQB fans shown herein are licensed to bear the AMCA Seal. The ratings shown are based on tests and procedures performed in accordance with AMCA Publication 211 and Publication 311 and comply with the requirements of the AMCA Certified Ratings Program. The certified ratings for model EQD and EQB are shown on pages 15 to 28.

UL is optional and must be specified. EQD and EQB models are listed for electrical (UL/cUL 705) File no. E40001.





## Standard Features

- 1. Housing**  
Unique octagonal housing is constructed of rigid structural members and formed galvanized steel panels.
- 2. Wheel**  
An aluminum mixed flow wheel is utilized to deliver maximum efficiency and low sound levels. Each wheel is statically and dynamically balanced.
- 3. Motor**  
Heavy-duty ball bearing motors are selected to provide years of trouble-free operation with minimal maintenance.
- 4. Straightening Vanes**  
Internally mounted straightening vanes improve fan efficiency by reducing the air spin.
- 5. Duct Collars**  
Bolt-on duct collars allow for slip-fit connection to ductwork as standard. Duct collars can be removed for a traditional bolted connection.

### Disconnect Switch

NEMA-1 disconnect switch is factory-mounted and wiring is provided from the motor as standard. All wiring and electrical components comply with the National Electrical Code® and materials are UL Listed. Other NEMA enclosure disconnect switches are optional.

**EQB**

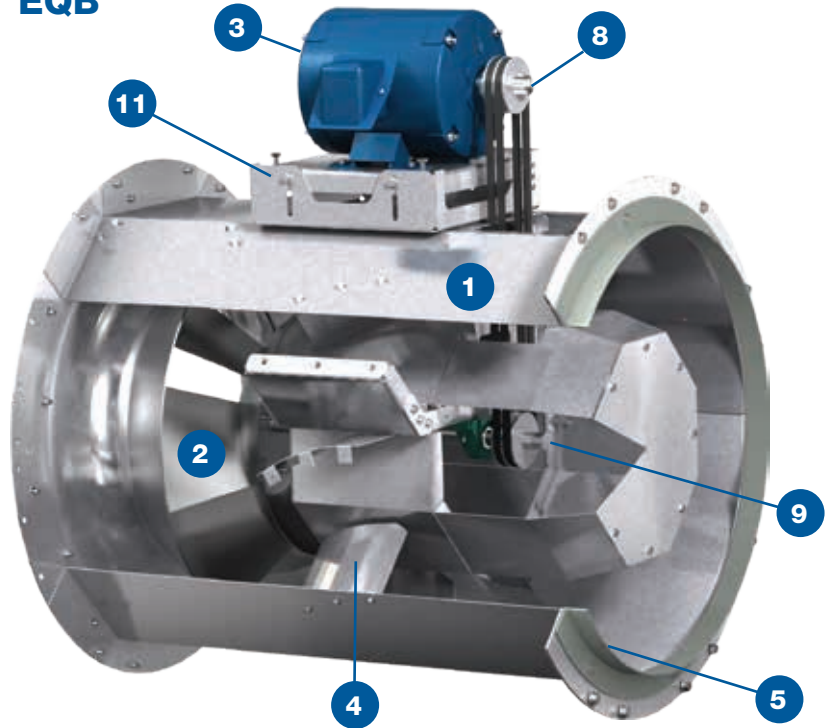

## EQD Features

- 6. Vari-Green® Motor**  
Greenheck's direct drive ECM Vari-Green Motor provides an easily controllable, highly efficient solution reducing system balancing time. This also reduces the overall cost of ownership.
- 7. Lifting Lugs**  
Standard lifting lugs allow for ease of maintenance, installation and commissioning, while helping ensure the safety of those working on the system.

**EQD**

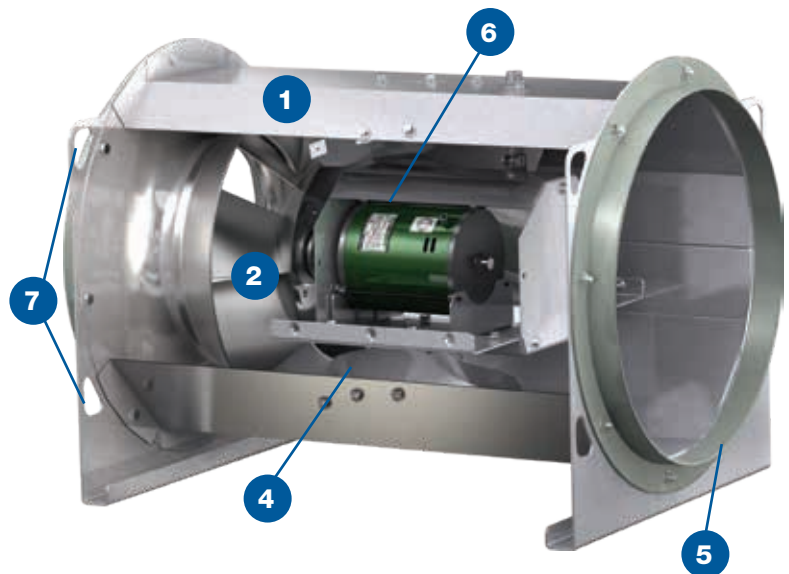



## EQB Features

### 8. Drive Assembly

Drives are sized for a minimum of 150% of driven horsepower. Machined cast iron pulleys are factory set to the required RPM and adjustable for final system balancing. Belts are static free and oil resistant. Belt adjustment is accomplished through adjustment of the motor plate.

### 9. Fan Shaft

Fan shafts are precisely sized, ground and polished so the first critical speed is at least 25% over the maximum operating speed. Close tolerances where the shaft makes contact with bearings result in longer bearing life.

### 10. External Belt Guard

An OSHA compliant external belt guard is provided with each fan to minimize air leakage around belts, resulting in higher fan efficiency and protection from moving belts and drives.

### 11. EZ-Tension System

Adjustable EZ-Tension System allows belt tensioning operations to be performed without external support for the weight of the motor.

### 12. Universal Mounting Supports *(shown at right)*

For ease of installation, two universal mounting supports are bolted to the fan.

**12a.** For motor positions “A” and “E” (12 and 6 o’clock), standard mounting supports are supplied.

**12b.** For motor positions “C” and “G” (3 and 9 o’clock), extended mounting supports are supplied.

As a part of Greenheck’s Universal Mounting System, either mounting support type can be removed and reinstalled on another side of the fan housing, allowing for multiple motor positions and mounting configurations.

### Bearings

100% factory tested bearings are designed specifically for air handling applications with a minimum L<sub>10</sub> average life in excess of 100,000 hours (L<sub>50</sub> average life in excess of 500,000 hours).

### Extended Lubrication Lines

Nylon lubrication lines with grease fittings allow bearing maintenance to be performed without disassembling the fan. Grease fittings are mounted on the outside of the fan housing.

Base Mount

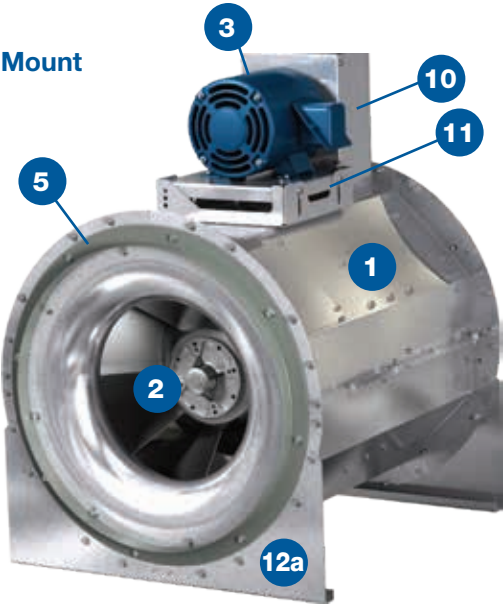

Hanging Supports

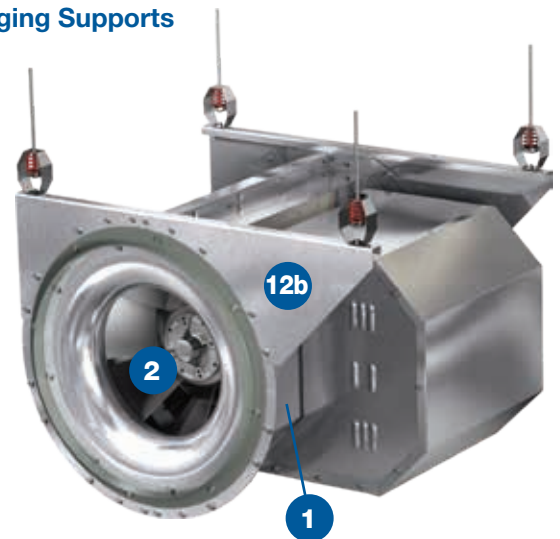

Multiple Motor Positions

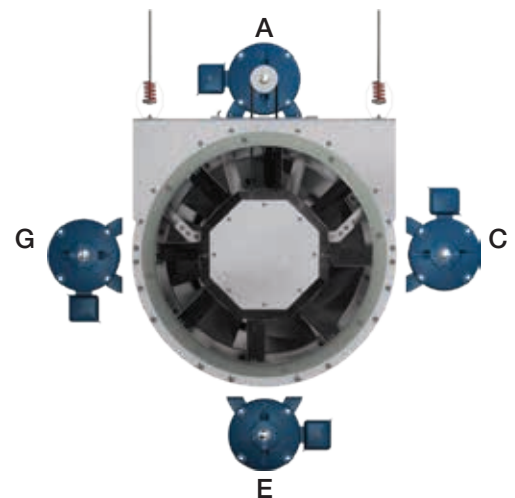

## Vari-Green® Motor - Model EQD

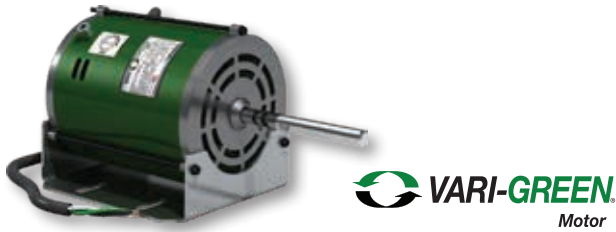

Greenheck's electronically commutated (EC) Vari-Green (VG) motor combines motor technology, controllability and energy-efficiency into one single low maintenance unit and is the industry's first fully controllable motor. When combined with Greenheck's EQD fans, all the CFM and static pressure ranges of a belt drive can be attained with the benefits of a direct drive.

Motor Information			
HP	RPM	Volts	Hertz
1/4	1725	115, 208-240/277	50/60
1/2	1725	115, 208-240/277	50/60
3/4	1725	115, 208-240/277	50/60
1	1725	115, 208-240/277	50/60
2	1725	208-240/277	50/60

### Benefits

Operates on AC power that's converted to DC— providing a more efficient motor operation as compared to an AC operation.

- The motor can attain up to 85% efficiency and reduce energy consumption.
- Watt savings of 30-70% depending on RPM.  
Note: As motor speed is turned down, efficiency stays high as compared to an AC motor that decreases dramatically.
- Operates cooler than a standard AC motor at lower RPMs. A cooler motor has longer motor life and reduces energy consumption.
- 80% usable RPM turndown vs. 30%.
- EQD fans with Vari-Green motors can provide all the CFM and static pressure ranges of a comparable belt drive.
- Maintenance costs are reduced as there are no belts or bearings to replace and no pulleys to adjust.
- Direct drive fans are often preferred where maintenance access is difficult.
- Provides a solution for demand controlled ventilation applications.

### Vari-Green Advantages

- Lower operating cost
- Low maintenance - no belts, pulleys or bearings
- Easy RPM adjustment

### Features

1. **Dial on Fan** - A potentiometer (dial on fan) is mounted on the fan for easy speed adjustment for system balance. Simply turn the dial; there are no belts and pulleys to adjust.
2. **Control Wire Inputs** - The motor accepts a 0-10 VDC signal from Building Automated Systems, Vari-Green Controls or other controls to adjust motor speed.

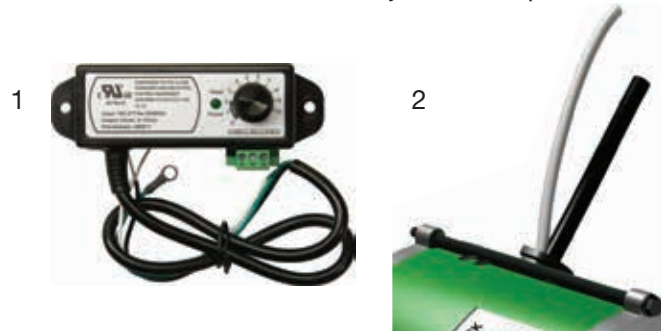



## Demand Control Ventilation for Multistory Buildings



Applications requiring constant pressure or variable volume can utilize EQD fans with Vari-Green motors and Vari-Green controls. Demand control ventilation systems reduce the amount of energy used by decreasing the speed of the fan when demand is low. This in turn lessens the amount of conditioned air exhausted and further reduces total operating costs associated with air conditioning and heating in multistoried buildings such as: hotels, multifamily complexes, institutional facilities, and high rise commercial buildings.

The Vari-Green constant pressure control is pre-programmed and easy-

### Variable Volume Operating Cost Analysis

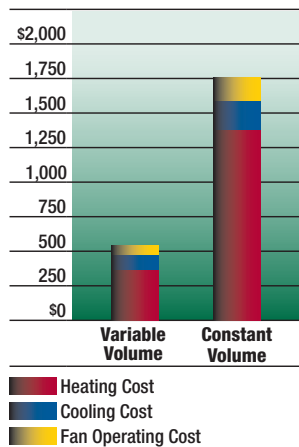

*Example of potential savings based on a northeast city in the USA using Vari-Green components for variable volume.*

to-install for applications that include: venting dryers, bathrooms, residential type kitchen space or industrial process exhaust.

Contact [fans@greenheck.com](mailto:fans@greenheck.com) for more information.

### Daily Operating Comparison: Variable Volume and Constant Volume

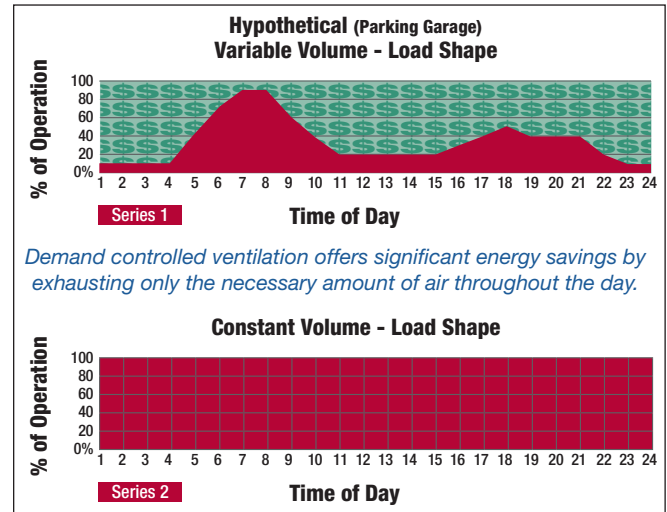

Note: A standard VFD compatible motor can also function within a variable volume system.

## Vari-Green® Controls

**Transformer** - Provides 24V power from the existing line voltage at the fan to the Vari-Green motor and controls. Dual voltage primary (120/240V) transformer provided with the fan.

**Remote Dial or Touch Remote** - Allows the user to manually adjust a fan's speed from a remote location and mounts to a wall using a 2x4 junction box.

**Two Speed Control with Integral Transformer** - Control allows motor rpm to be set at two independent speeds (high or low). Meets minimum airflow requirements with the ability to bump up to high speed in an emergency or meet maximum airflow requirements, or reset to low for energy conservation.

**Constant Pressure Control - Indoor** - Control Vari-Green motor via static (variable volume) or velocity (constant CFM) pressure on the inlet or outlet side of the fan. Optional, one or two, duct or room probes for use in:

- Multifamily structures - Apartments, condos, hotels; dryer facilities, residential kitchens and bathrooms.
- Institutional facilities - Schools, prisons, multistory office buildings; bathrooms.

### Constant Pressure Control - Outdoor

Control Vari-Green motor via static pressure on the inlet side of the fan. Includes one duct probe and transducer for use in:

- Multifamily structures - Apartments, condos, hotels; dryer facilities, residential kitchens and bathrooms.
- Institutional facilities - Schools, prisons, multistory.

**Air Quality – VOC** - Control a Vari-Green motor via changes in volatile organic compounds (VOC's). VOC's are gasses that are emitted from humans, building materials, perfumes, foods, and furniture off-gassing. Range is 0-2000 CO<sub>2</sub> ppm equivalent.

- Institutional facilities – Schools, court houses, hospitals; bathrooms, waiting rooms, cafeterias.
- Commercial buildings – Office space, conference rooms, bathrooms, break rooms.

**Air Quality – Temperature and Humidity** - Control Vari-Green motor via changes in temperature, humidity, or both. Range is 32 to 120°F and 0 to 100% relative humidity.

- Multifamily structures – Apartments, condos, hotels; bathrooms, utility rooms.
- Commercial buildings – Office buildings; office space, conference rooms, utility rooms, bathrooms.



## 1. Motor Cover

Galvanized steel motor covers shield motor components from dust, dirt and moisture for indoor installations. Motor covers also serve as personnel guards.

## 2. Inlet and Outlet Guards

Removable inlet and outlet guards provide protection of equipment in ducted or non-ducted applications. Standard outlet guard construction is galvanized steel.

## 3. Vibration Isolators

Vibration isolators reduce unit vibration and noise. Both base mount and hanging isolators are available in either neoprene or spring mounts.

## 4. Access Door

Galvanized steel access door allows access to the wheel for easy cleaning/maintenance.

- Up to four access doors for EQD only.

## Disconnect Switches

Assorted NEMA rated switches are available for positive electrical shutoff and safety.



## Extended Wiring Pigtail

Nine foot wiring extension allows direct hook-up to the power supply, eliminating field wiring at the fan.

## Thrust Restraints

Thrust restraints are used to neutralize the discharge force created by fans during operation. They are generally used on the discharge of the fan spanning the flex-connect from the fan to the ductwork. Recommended on installations where thrust exceeds 10% of total equipment weight (fan, motor and all accessories).



## Coatings

Wide variety of coatings and colors are available. Decorative coatings are available in sixteen standard colors. Protective coatings are available in a choice of five electrostatically applied powders providing an available selection for most environments.

All Greenheck coatings and resistance charts can be found in our Performance Coatings for Commercial & Industrial Fans brochure.

## Motor Starters

The fundamental function of a motor starter is to protect the motor from damage that can occur from overamping. With a Greenheck motor starter you will be provided with the best motor protection available.

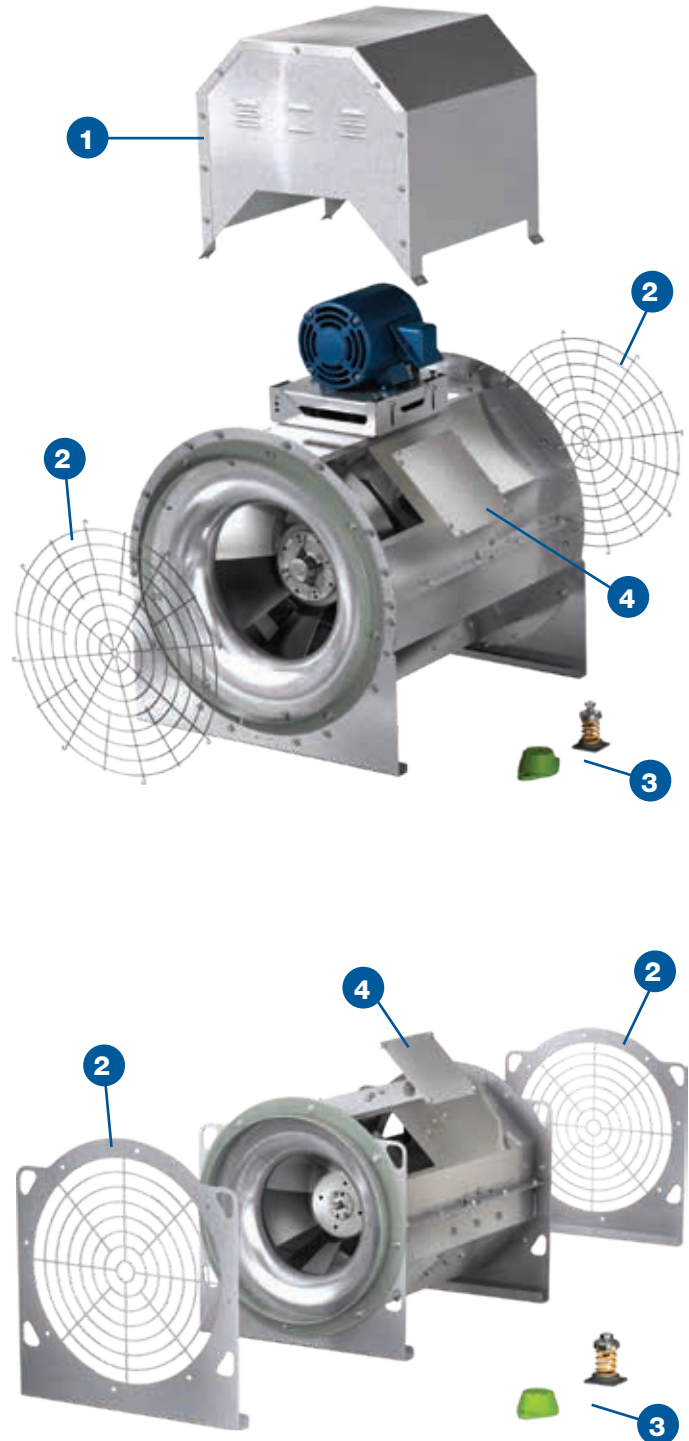





## Life Testing

Extensive life testing was conducted on models EQB and EQD to ensure years of reliable performance. Testing included the following:

- Finite Element Analysis (FEA)
  - Utilizing FEA software, the design of the fan was examined using 3D models in order to improve its structural strength.
- “Start-Stop” fatigue testing
  - The wheel and fully assembled fan were run for over 100,000 cycles in “Start-Stop” fatigue tests.
- Computational Fluid Dynamics (CFD) modeling
  - CFD modeling was used to examine airflow through model EQB to enhance design and optimize performance.

## Inlet Sound Testing

Models EQB and EQD were tested in our AMCA Accredited Sound Laboratory. All EQB and EQD fans have AMCA licensed sound power levels for the fan inlet. For additional information on sound, refer to page 10.

## Quality Assurance Test

A quality assurance test is performed on each EQB and EQD fan at the factory prior to shipping. This test includes RPM and amp draw measurements, and a vibration check.

## EQB Serviceable Construction

Model EQB has several features incorporated into the design to make field service and maintenance quick and easy.

- Bearing lubrication is performed through extended lubrication lines with grease fittings located on the outside of the fan housing.
- An adjustable EZ-Tension System allows belt tensioning operations to be performed without external support for the weight of the motor.
- The fan shaft and bearings can be removed as a single assembly from the fan housing.

## Slip-Fit Duct Connections

Duct collars are bolted to the fan’s inlet and outlet flanges to provide a slip-fit connection for a flexible sleeve. The advantages of a flexible transition are:

- Decreased sound transmission in the ductwork
- Flexible connections allow for minor misalignment
- Accommodates the use of thrust restraints to resist thrust loads

## AutoCAD® and Revit® 3D Models

Scaled AutoCAD drawings and Revit models are available in CAPS or through Greenheck’s website.

## Mixed Flow: Axial/Centrifugal Hybrid

A mixed flow wheel is a hybrid between an axial propeller and a centrifugal wheel. The result is a design that combines the best axial and centrifugal properties: highly efficient air movement, increased pressure capabilities, extremely low sound levels, and a steep fan performance curve. To further enhance the fan’s performance, straightening vanes are incorporated in the housing. These serve to convert swirling airflow into a straight axial flow with a resulting static pressure rise and energy savings.

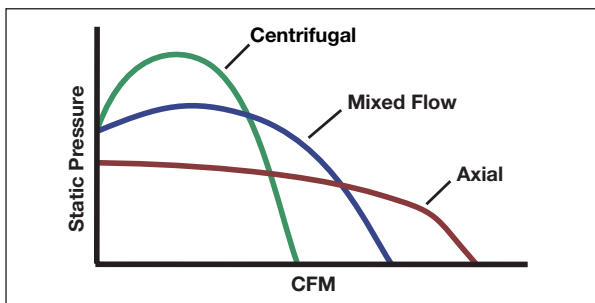

## Airflow Profiles



**Axial Fans:**  
Straight through nearly linear airflow.



**Centrifugal Fans:**  
Two 90° deflections, before airflow exits the fan.



**Mixed Flow Fans:**  
Slight airflow deflection from straight through.

# EQB Belt Drive Design & Performance Comparison



## EQB Fan Efficiency (AT RIGHT)

With its innovative housing and mixed flow wheel, model EQB is designed to deliver extremely efficient performance in any application. This high efficiency level can lead to lower annual operating costs and significant energy savings for green building projects. In fact, model EQB offers higher efficiency and lower operating costs than square and tubular centrifugal fans, with a lower initial cost than traditional mixed flow fans.

The static efficiencies and life cycle costs of several types of inline fans are compared in the graphs.

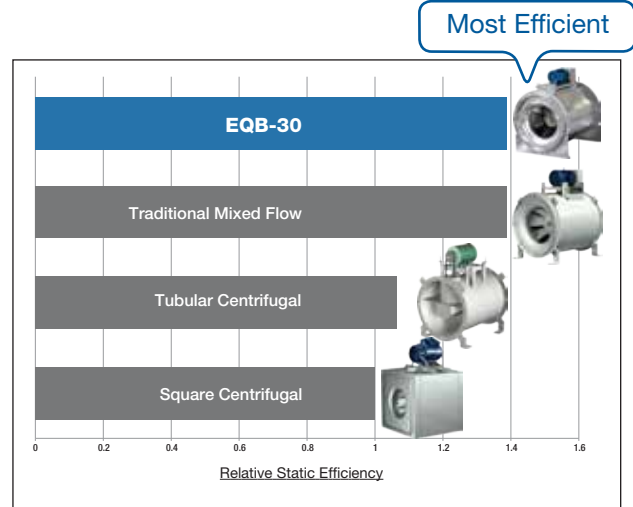
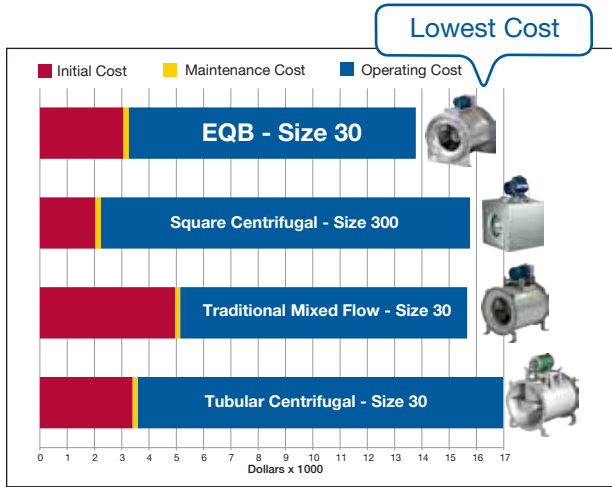

## Total Cost of Ownership Comparison (AT LEFT)

The total cost of ownership analysis shown in the graph is based on operating costs for a period of three years where the fans operate continuously at 1725 rpm, 24/7, with an energy rate of \$0.10/kWh. Fans were selected for 10,000 cfm at 2 in. wg of static pressure. Maintenance costs were estimated at \$65/yr. Note: Example is based on a relative cost. Use and installation variables may produce different results.

## Lower Sound Power, Better Sound Quality (AT RIGHT)

The sound quality of a mixed flow fan is as beneficial to low sound design as the reduced overall sound power. The sound chart compares units of similar outer tube diameters at an operating point of 12,000 cfm at 2 in. wg of static pressure (Ps). Tubular centrifugals (green) have dominant tones in the 63 Hz through 250 Hz octave bands, while vane axials (red) have more mid to high frequency sound. The EQB mixed flow fan (blue) does not have a dominant tone. A bystander would hear a more bland sound which is quieter than a tubular centrifugal or vane axial fan.

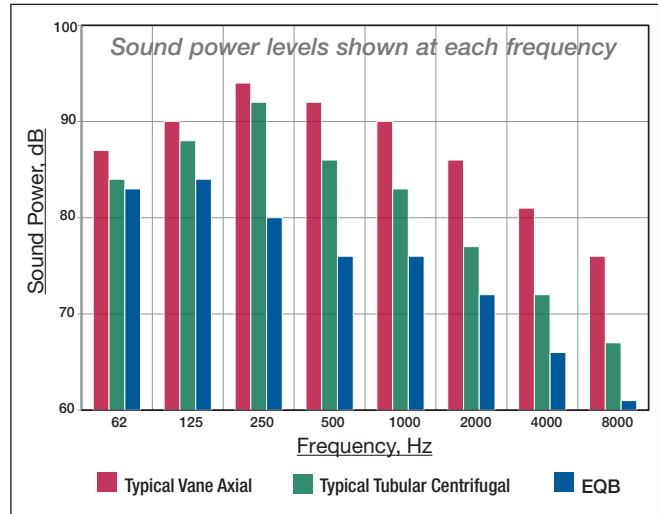

	5,000 cfm @ 1.0 in. wg		7,500 cfm @ 1.5 in. wg		15,000 cfm @ 2.0 in. wg	
	Sound Power (L <sub>WA</sub> )	Static Efficiency	Sound Power (L <sub>WA</sub> )	Static Efficiency	Sound Power (L <sub>WA</sub> )	Static Efficiency
Vane Axial	103 dB	21%	87 dB	59%	99 dB	55%
Tubular Centrifugal	84 dB	33%	79 dB	51%	94 dB	41%
Mixed Flow (EQB)	76 dB	62%	74 dB	65%	83 dB	71%

Model comparisons based on similar outer tube diameters.

## Sound and Efficiency (AT LEFT)

Sound power levels and fan efficiency are two very important factors when selecting a fan. There is a noticeable difference between impeller types. The table compares the sound power (L<sub>WA</sub>) and the static efficiency of the belt-driven mixed flow fan wheel versus tubular centrifugal and vane axial inline fans. Over a wide range of operating points, the mixed flow fan provides the quietest and most efficient selection.

# Mounting Configurations Model EQD



Model EQD can be mounted in 45° increments.

Base



Angled

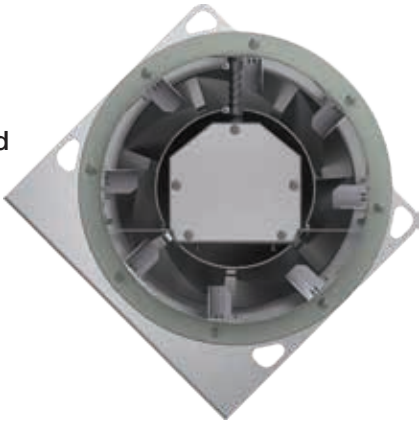

Wall

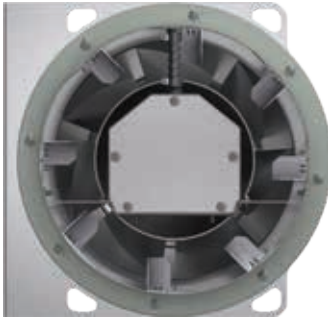

Ceiling

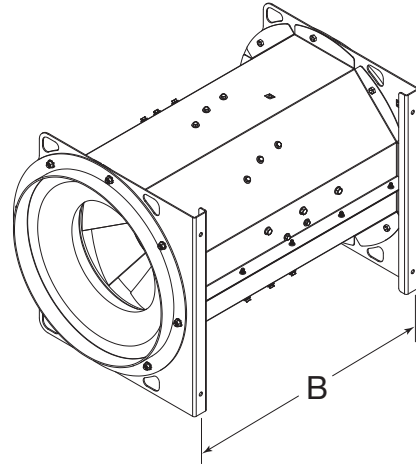
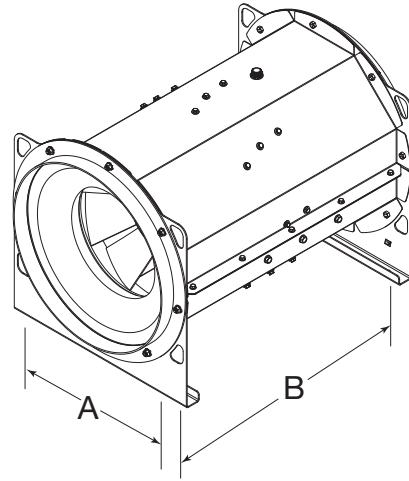
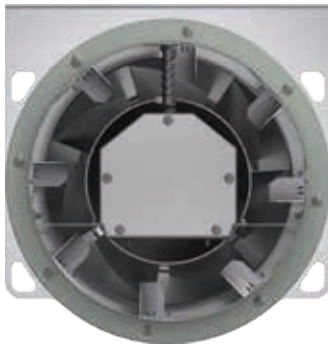

Model	A	B
EQD 9	12 <sup>3</sup> / <sub>4</sub> (324)	21 <sup>2</sup> / <sub>3</sub> (550)
EQD 12	16 <sup>1</sup> / <sub>4</sub> (413)	25 (635)
EQD 15	19 <sup>7</sup> / <sub>8</sub> (505)	27 <sup>5</sup> / <sub>8</sub> (702)

Dimensions are in inches (millimeters)

# Mounting Configurations Model EQB



## Universal Mounting

All EQB fans can be mounted in both hanging and base-mounted horizontal configurations. For ease of installation, two mounting supports are bolted to the fan. As a part of Greenheck's Universal Mounting System, these supports can be removed and reinstalled on another side of the fan housing, allowing for multiple motor positions and mounting configurations.

**Motor positions are viewed from the discharge end of the fan.**



**Horizontal Base Mount with motor at "C" or "G" position (3 or 9 o'clock).**

Extended mounting supports are supplied for this installation.



**Horizontal Ceiling Hung with motor at "C" or "G" position (3 or 9 o'clock).**

Extended mounting supports are supplied for this installation.



### Horizontal Base Mount

Each fan is shipped as standard in this arrangement. Motor at "A" position (12 o'clock) is standard.



### Horizontal Ceiling Hung

In this installation the supports can be positioned for mounting the motor at "A" or "E" (12 or 6 o'clock).



### Vertical Mounting

EQB fans can be selected for vertical mounting, offering more options for installation. This feature supports both upward and downward airflow application.

## Field Rotatable Housing

Model EQB is designed to accommodate last minute changes in motor mounting position while in the field. By simply rotating the fan housing, the orientation of the motor can be adjusted to any of the positions as shown.

**Motor positions are viewed from the discharge end of the fan.**

**Note:** Field rotation from motor positions A or E to positions C or G requires field-supplied mounting rails or replacement extended mounting supports from the factory.

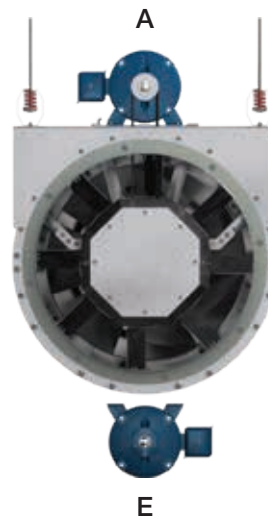

Horizontal - Ceiling Hung

# Mounting Configurations Model EQB

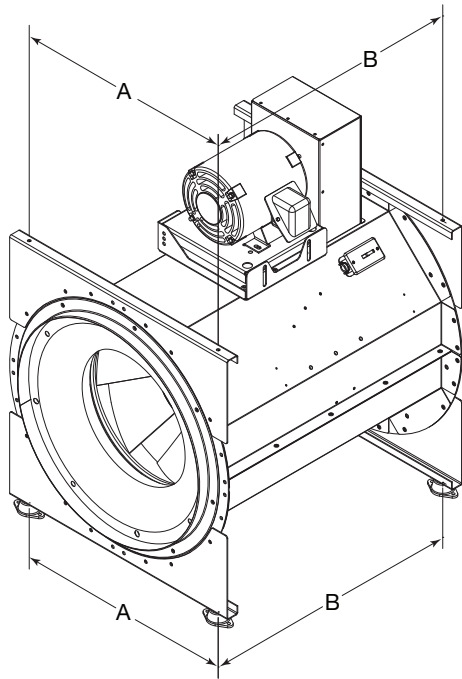

### Horizontal Hanging or Base Mount

With a hanging mount, the motor may be located on either the top or bottom of the housing. Base mounting allows the motor to be located on top only. In these configurations, standard mounting supports are provided.

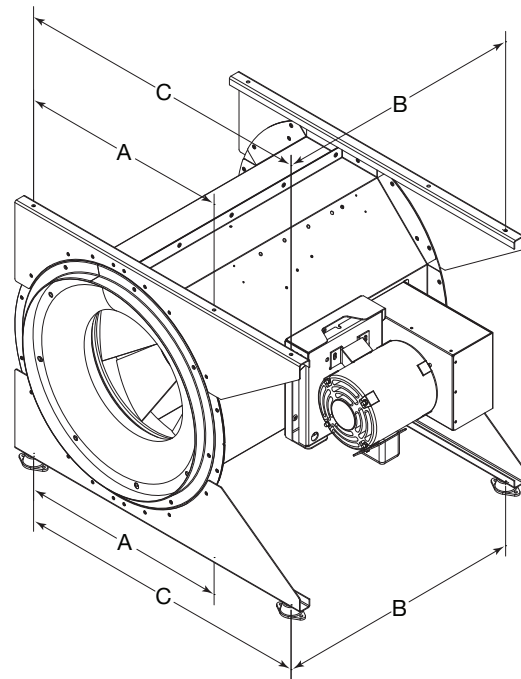

### Horizontal Hanging or Base Mount

The motor may be located on either side of the housing with a horizontal hanging or base mount. In these configurations, extended mounting supports are provided.

Model	A	B	C
EQB 9	15 <sup>3</sup> / <sub>8</sub> (391)	22 (559)	20 <sup>3</sup> / <sub>8</sub> (518)
EQB 12	18 <sup>3</sup> / <sub>8</sub> (467)	25 <sup>1</sup> / <sub>8</sub> (638)	27 <sup>3</sup> / <sub>4</sub> (705)
EQB 15	22 <sup>1</sup> / <sub>8</sub> (562)	27 <sup>7</sup> / <sub>8</sub> (702)	33 <sup>1</sup> / <sub>2</sub> (851)
EQB 16	24 <sup>1</sup> / <sub>4</sub> (616)	29 <sup>5</sup> / <sub>8</sub> (752)	35 <sup>1</sup> / <sub>2</sub> (902)
EQB 18	26 <sup>3</sup> / <sub>8</sub> (676)	31 <sup>3</sup> / <sub>8</sub> (803)	38 (965)
EQB 20	28 <sup>7</sup> / <sub>8</sub> (733)	34 <sup>1</sup> / <sub>8</sub> (867)	40 (1016)
EQB 22	31 <sup>3</sup> / <sub>4</sub> (806)	37 <sup>5</sup> / <sub>8</sub> (956)	44 <sup>1</sup> / <sub>2</sub> (1130)
EQB 24	36 (914)	41 <sup>1</sup> / <sub>8</sub> (1045)	47 <sup>1</sup> / <sub>4</sub> (1200)
EQB 27	38 <sup>1</sup> / <sub>2</sub> (978)	43 <sup>5</sup> / <sub>8</sub> (1108)	52 (1321)
EQB 30	44 <sup>1</sup> / <sub>2</sub> (1130)	50 <sup>3</sup> / <sub>8</sub> (1286)	58 <sup>7</sup> / <sub>8</sub> (1495)
EQB 33	48 <sup>1</sup> / <sub>2</sub> (1232)	55 <sup>1</sup> / <sub>8</sub> (1400)	62 <sup>7</sup> / <sub>8</sub> (1597)

Dimensions are in inches (millimeters)

# Typical Installation



Model EQD and EQB mixed flow inline fans are designed for the exhaust, supply or recirculation of air in a building. Typical installation requires a minimum of one equivalent duct diameter of straight ductwork on the inlet and three equivalent duct diameters of straight ductwork on the outlet side of the fan to minimize system effect losses. See the diagram below for a typical installation.

Installations should include flexible duct connections (by others) on either the inlet or outlet side of the fan or both. The motor is rigidly mounted and can be oriented in any direction (top, bottom, side), but must be accessible for maintenance and inspection.

Either hanging or base mounted external isolators are also recommended to help reduce vibration and noise.

Installation must meet all local governing codes and the NEC®.

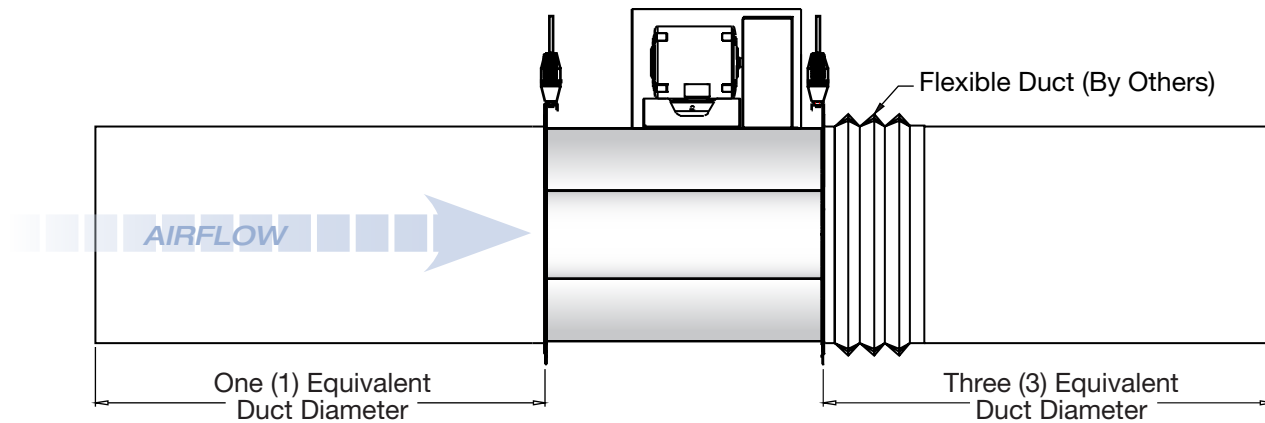

## Model Number Code

The model number system is designed to identify the fan by the size and performance selected from the following pages.

**EQB - 15 - VG/10 - X**

<p><b>MODEL CONFIGURATION</b></p> <p>EQB - Belt Drive Inline Exhaust EQD - Direct Drive Inline Exhaust</p>	<p><b>FAN SIZE</b></p> <p>9 through 33</p>	<p><b>MOTOR HP</b></p> <table border="0"> <tr> <td>4 = 1/4</td> <td>10 = 1</td> <td>50 = 5</td> </tr> <tr> <td>3 = 1/3</td> <td>15 = 1½</td> <td>75 = 7½</td> </tr> <tr> <td>5 = 1/2</td> <td>20 = 2</td> <td>100 = 10</td> </tr> <tr> <td>7 = 3/4</td> <td>30 = 3</td> <td>150 = 15</td> </tr> </table>	4 = 1/4	10 = 1	50 = 5	3 = 1/3	15 = 1½	75 = 7½	5 = 1/2	20 = 2	100 = 10	7 = 3/4	30 = 3	150 = 15
4 = 1/4	10 = 1	50 = 5												
3 = 1/3	15 = 1½	75 = 7½												
5 = 1/2	20 = 2	100 = 10												
7 = 3/4	30 = 3	150 = 15												

UL 705

VG = Vari-Green®  
(Direct Drive only)

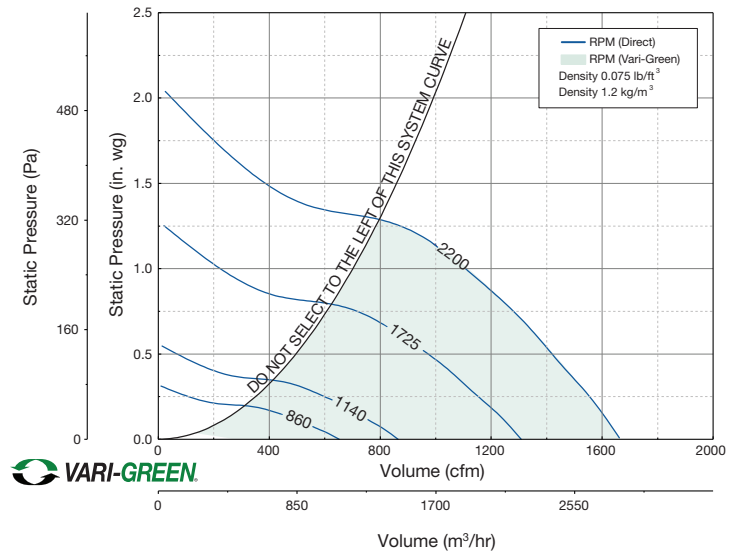
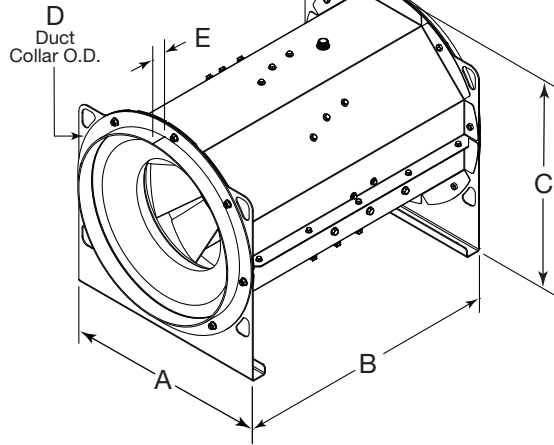

A	B	C	D (Duct Collar O.D.)	E	Unit Weight (LMD) = 53 (24)	Dimensions shown in inches (millimeters). Weight shown in pounds (kilograms).
16¾ (425)	21¾ (552)	17⅞ (454)	15¾ (400)	1½ (38)		

Motor HP	Fan RPM		CFM / Static Pressure in Inches wg							
			0.000	0.125	0.250	0.500	0.750	1.000	1.250	
<b>VG - 1/4</b>  	860	CFM	652	483						
		BHP	0.011	0.016						
		Sones	5.6	5.3						
	1140	CFM	864	746	599					
		BHP	0.026	0.033	0.040					
		Sones	7.4	6.9	6.7					
	1725	CFM	1308	1239	1153	972	706			
		BHP	0.090	0.099	0.110	0.130	0.140			
		Sones	10.4	10.3	10.2	10.1	9.7			
<b>VG - 3/4</b>	2200	CFM	1668	1614	1556	1421	1279	1105	854	
		BHP	0.190	0.200	0.210	0.240	0.270	0.290	0.290	
		Sones	13.8	13.2	12.6	11.4	11.2	10.9	10.7	

Performance certified is for installation type B: Free inlet, Ducted outlet. Performance ratings do not include the effects of appurtenances (accessories). The sound ratings shown are loudness values in fan sones at 1.5 m (5 feet) in a hemispherical free field calculated per AMCA International Standard 301. Values shown are for installation type B: free inlet hemispherical sone levels.

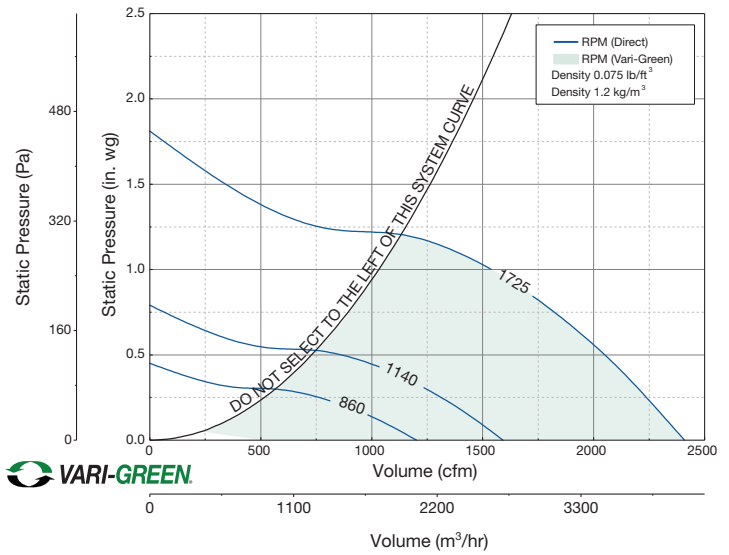
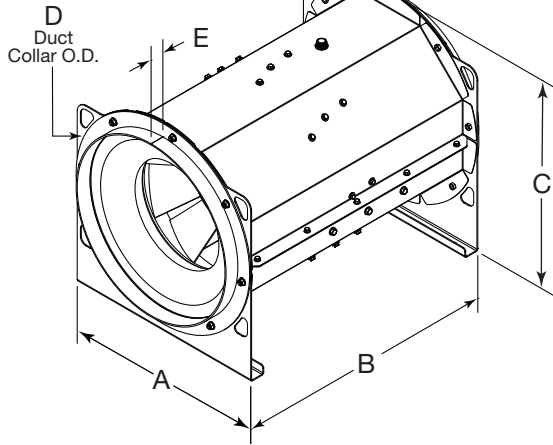

A	B	C	D (Duct Collar O.D.)	E	Unit Weight (LMD) = 69 (32)	Dimensions shown in inches (millimeters). Weight shown in pounds (kilograms).
20 <sup>1</sup> / <sub>4</sub> (413)	25 (635)	21 <sup>1</sup> / <sub>8</sub> (537)	18 <sup>3</sup> / <sub>4</sub> (476)	1 <sup>1</sup> / <sub>2</sub> (38)		

Motor HP	Fan RPM		CFM / Static Pressure in Inches wg						
			0.000	0.125	0.250	0.500	0.750	1.000	1.250
VG - 3/4 	860	CFM	1201	1019	759				
		BHP	0.030	0.040	0.048				
		Sones	5.8	5.1	4.7				
	1140	CFM	1592	1461	1314	844			
		BHP	0.069	0.083	0.097	0.110			
		Sones	7.3	7.0	6.9	6.0			
	1725	CFM	2409	2324	2237	2047	1822	1532	
		BHP	0.240	0.260	0.280	0.330	0.370	0.380	
		Sones	12.9	12.2	11.3	11.1	11.2	11.0	

Performance certified is for installation type B: Free inlet, Ducted outlet. Performance ratings do not include the effects of appurtenances (accessories). The sound ratings shown are loudness values in fan sones at 1.5 m (5 feet) in a hemispherical free field calculated per AMCA International Standard 301. Values shown are for installation type B: free inlet hemispherical sone levels.



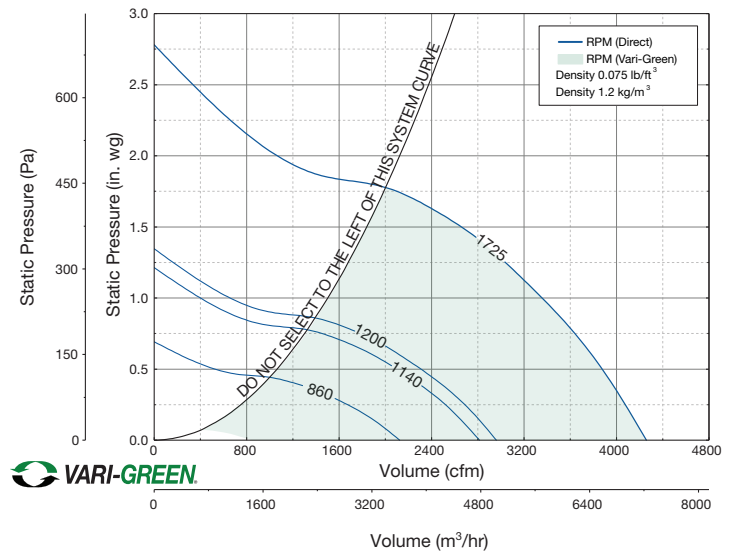
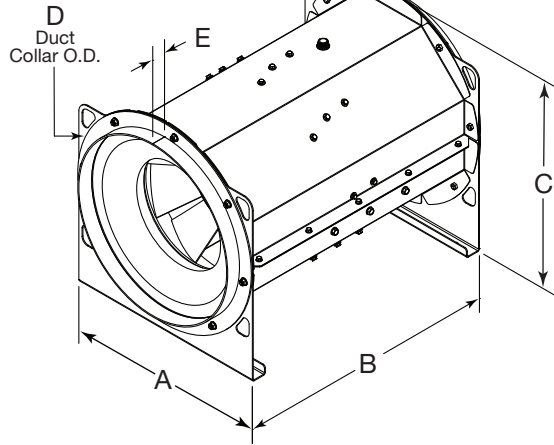

A	B	C	D (Duct Collar O.D.)	E	Unit Weight (LMD) = 102 (47)	Dimensions shown in inches (millimeters). Weight shown in pounds (kilograms).
23 <sup>7</sup> / <sub>8</sub> (606)	27 <sup>7</sup> / <sub>8</sub> (702)	25 (635)	22 <sup>7</sup> / <sub>8</sub> (575)	1 <sup>1</sup> / <sub>2</sub> (38)		

Motor HP	Fan RPM		CFM / Static Pressure in Inches wg									
			0.000	0.125	0.250	0.500	0.750	1.000	1.250	1.500	1.750	
<b>VG - 1</b> 	860	CFM	2122	1928	1668							
		BHP	0.074	0.099	0.120							
		Sones	7.4	6.9	6.9							
	1140	CFM	2814	2674	2517	2099	1426					
		BHP	0.170	0.210	0.240	0.290	0.300					
		Sones	10.2	9.8	9.3	8.9	8.5					
	1200	CFM	2962	2829	2682	2304	1774					
		BHP	0.200	0.240	0.270	0.330	0.350					
		Sones	10.7	10.2	9.8	9.5	9.1					
<b>VG - 2</b>	1725	CFM	4257	4165	4073	3870	3633	3353	3032	2641	2072	
		BHP	0.59	0.65	0.70	0.80	0.89	0.97	1.02	1.05	1.01	
		Sones	18.0	17.7	16.7	15.7	15.4	15.2	15.3	15.3	15.3	16.0

Performance certified is for installation type B: Free inlet, Ducted outlet. Performance ratings do not include the effects of appurtenances (accessories).  
 The sound ratings shown are loudness values in fan sones at 1.5 m (5 feet) in a hemispherical free field calculated per AMCA International Standard 301.  
 Values shown are for installation type B: free inlet hemispherical sone levels.

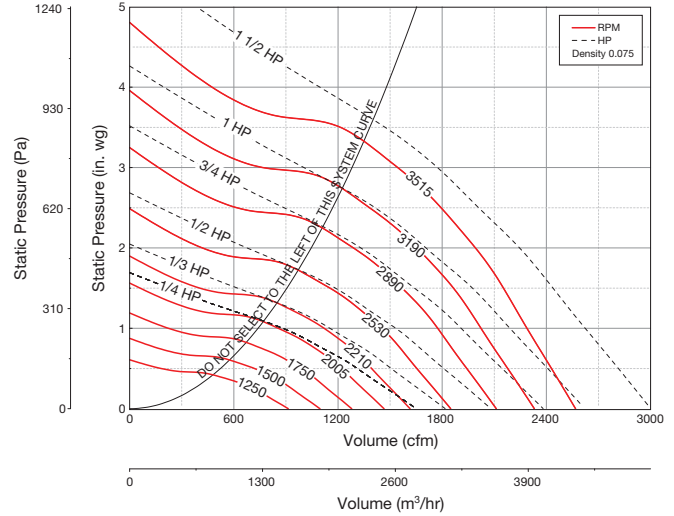
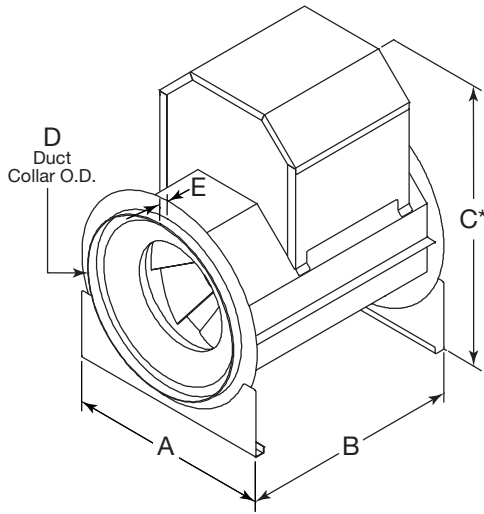

A	B	C*	D	E	Unit Weight (LMD) = 61 (28)	Dimensions shown in inches (millimeters). Weight shown in pounds (kilograms). *Motor cover is optional. Size may be greater depending on motor.
19 3/8 (492)	22 (559)	28 3/4 (730)	14 1/4 (362)	1 3/8 (35)		

Fan RPM		CFM / Static Pressure in Inches wg											
		0.125	0.250	0.500	0.750	1.00	1.25	1.50	1.75	2.00	2.25	2.50	3.00
900	CFM	517											
	BHP	0.021											
	Sones	3.8											
1250	CFM	815	709										
	BHP	0.049	0.056										
	Sones	5.9	5.5										
1500	CFM	1014	932	716									
	BHP	0.082	0.09	0.1									
	Sones	7.4	7.1	6.6									
1750	CFM	1209	1138	986	760								
	BHP	0.13	0.14	0.15	0.16								
	Sones	9.0	8.8	8.5	8.2								
2005	CFM	1404	1343	1221	1067	856							
	BHP	0.19	0.2	0.22	0.24	0.24							
	Sones	10.4	10.2	9.8	9.5	9.3							
2210	CFM	1560	1504	1393	1272	1117	906						
	BHP	0.25	0.26	0.28	0.3	0.32	0.33						
	Sones	11.5	11.3	10.9	10.5	10.4	10.2						
2530	CFM	1800	1752	1654	1558	1448	1314	1149					
	BHP	0.37	0.38	0.41	0.43	0.46	0.48	0.49					
	Sones	14.4	14.0	13.2	12.5	12.0	12.0	12.1					
2890	CFM	2069	2027	1942	1856	1772	1677	1568	1441	1285			
	BHP	0.54	0.56	0.59	0.62	0.65	0.68	0.7	0.72	0.73			
	Sones	17.5	17.0	16.2	15.5	14.7	14.0	14.0	14.1	14.1			
3190	CFM	2292	2254	2177	2100	2023	1947	1861	1762	1651	1530	1380	
	BHP	0.72	0.74	0.78	0.81	0.85	0.88	0.91	0.94	0.96	0.97	0.98	
	Sones	21	20	19.2	18.3	17.5	16.9	16.1	15.9	15.9	16.0	16.0	
3515	CFM	2533	2499	2429	2359	2288	2219	2150	2076	1986	1894	1790	1540
	BHP	0.96	0.98	1.02	1.06	1.1	1.14	1.17	1.21	1.24	1.27	1.29	1.31
	Sones	25	24	23	22	21	20	19.6	18.9	18.4	18.4	18.4	18.5

MAX Bhp AT A GIVEN RPM = (rpm/3196)<sup>3</sup>  
 MAXIMUM RPM = 3515  
 TIP SPEED (ft/min) = rpm x 3.21  
 MAX NEMA MOTOR FRAME SIZE = 145T  
 OUTLET VELOCITY (ft/min) = cfm/1

Performance certified is for installation type B: Free inlet, Ducted outlet. Power rating (Bhp) does not include transmission losses. Performance ratings do not include the effects of appurtenances (accessories).

The sound ratings shown are loudness values in fan sones at 1.5 m (5 feet) in a hemispherical free field calculated per AMCA International Standard 301. Values shown are for installation type B: free inlet hemispherical sone levels.

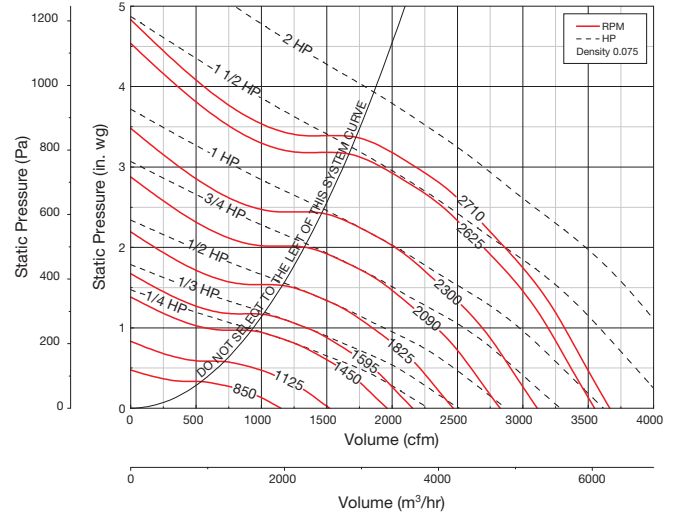
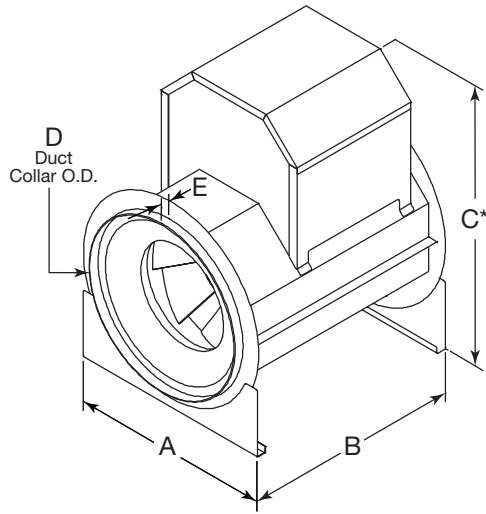

<b>A</b>	<b>B</b>	<b>C*</b>	<b>D</b>	<b>E</b>	Unit Weight (LMD) = 105 (48)	Dimensions shown in inches (millimeters). Weight shown in pounds (kilograms). *Motor cover is optional. Size may be greater depending on motor.
22 <sup>5</sup> / <sub>16</sub> (575)	26 <sup>5</sup> / <sub>16</sub> (676)	32 <sup>3</sup> / <sub>4</sub> (832)	17 <sup>1</sup> / <sub>2</sub> (445)	1 <sup>1</sup> / <sub>2</sub> (38)		

Fan RPM		CFM / Static Pressure in Inches wg											
		0.125	0.250	0.500	0.750	1.00	1.25	1.50	1.75	2.00	2.25	2.50	3.00
850	CFM	1009	797										
	BHP	0.041	0.049										
	Sones	6.2	6.3										
1125	CFM	1416	1301	939									
	BHP	0.086	0.098	0.12									
	Sones	7.6	7.2	7.1									
1450	CFM	1879	1798	1605	1334								
	BHP	0.17	0.19	0.22	0.25								
	Sones	9.6	9.3	8.6	8.3								
1595	CFM	2083	2008	1847	1629	1338							
	BHP	0.23	0.24	0.28	0.31	0.33							
	Sones	10.6	10.3	9.7	9.2	8.9							
1825	CFM	2403	2338	2208	2049	1848	1607	1217					
	BHP	0.34	0.36	0.39	0.43	0.47	0.49	0.49					
	Sones	12.7	12.3	11.7	11.0	10.6	10.2	9.9					
2090	CFM	2769	2713	2600	2483	2336	2161	1968	1716	1341			
	BHP	0.5	0.52	0.56	0.61	0.65	0.7	0.73	0.75	0.73			
	Sones	16.0	15.5	14.6	13.7	13.0	12.5	12.1	11.7	11.8			
2200	CFM	2921	2867	2760	2652	2520	2367	2193	2006	1742			
	BHP	0.58	0.6	0.65	0.69	0.74	0.79	0.83	0.86	0.87			
	Sones	17.2	16.8	15.9	15.0	14.1	13.4	13.2	12.8	12.4			
2300	CFM	3058	3007	2904	2801	2684	2550	2387	2214	2011	1730		
	BHP	0.66	0.68	0.73	0.78	0.83	0.88	0.93	0.97	0.99	0.99		
	Sones	18.4	17.9	17.1	16.2	15.3	14.5	14.1	13.8	13.4	13.1		
2625	CFM	3504	3459	3369	3279	3189	3088	2971	2842	2698	2545	2388	1885
	BHP	0.97	1	1.05	1.11	1.16	1.22	1.27	1.33	1.39	1.43	1.47	1.47
	Sones	23	23	22	21	19.9	19.0	18.0	17.3	17.0	16.8	16.6	16.4
2710	CFM	3620	3577	3490	3403	3315	3225	3112	2998	2859	2718	2565	2176
	BHP	1.07	1.1	1.15	1.21	1.26	1.32	1.38	1.44	1.5	1.55	1.59	1.63
	Sones	25	25	24	23	22	21	19.8	18.9	18.5	18.3	18.1	17.8

MAX Bhp AT A GIVEN RPM = (rpm/2301)<sup>3</sup>  
 MAXIMUM RPM = 2710  
 TIP SPEED (ft/min) = rpm x 3.93  
 MAX NEMA MOTOR FRAME SIZE = 145T  
 OUTLET VELOCITY (ft/min) = cfm/1.56

Performance certified is for installation type B: Free inlet, Ducted outlet. Power rating (Bhp) does not include transmission losses. Performance ratings do not include the effects of appurtenances (accessories). The sound ratings shown are loudness values in fan sones at 1.5 m (5 feet) in a hemispherical free field calculated per AMCA International Standard 301. Values shown are for installation type B: free inlet hemispherical sone levels.

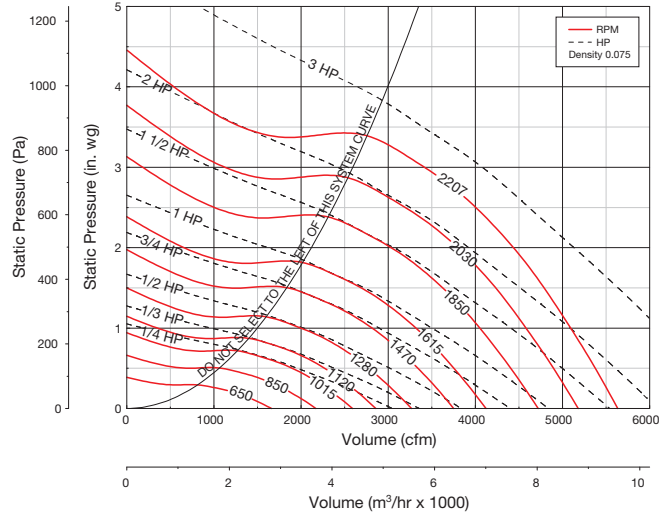
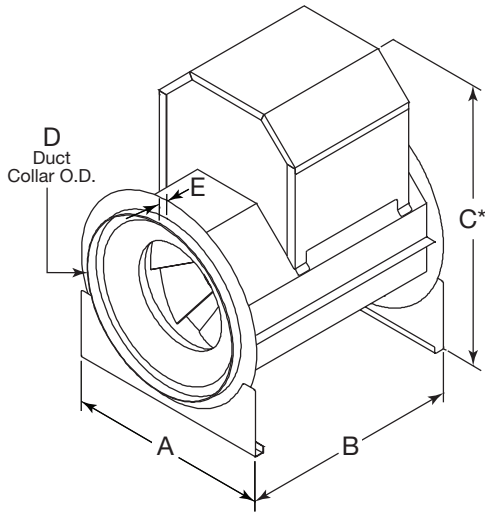

A	B	C*	D	E	Unit Weight (LMD) = 137 (62)	Dimensions shown in inches (millimeters). Weight shown in pounds (kilograms). *Motor cover is optional. Size may be greater depending on motor.
26 <sup>3</sup> / <sub>8</sub> (670)	29 <sup>1</sup> / <sub>8</sub> (740)	38 (965)	21 <sup>1</sup> / <sub>8</sub> (537)	1 <sup>1</sup> / <sub>2</sub> (38)		

Fan RPM		CFM / Static Pressure in Inches wg											
		0.125	0.250	0.500	0.750	1.00	1.25	1.50	1.75	2.00	2.25	2.50	3.00
650	CFM	1418	1046										
	BHP	0.056	0.065										
	Sones	4.4	3.5										
850	CFM	1994	1795										
	BHP	0.11	0.13										
	Sones	6.5	5.9										
1015	CFM	2448	2291	1893									
	BHP	0.18	0.2	0.24									
	Sones	8.7	8.2	6.9									
1120	CFM	2730	2591	2267	1783								
	BHP	0.23	0.26	0.31	0.33								
	Sones	9.8	9.3	8.3	6.9								
1280	CFM	3155	3036	2776	2461	1991							
	BHP	0.34	0.37	0.43	0.47	0.49							
	Sones	11.6	11.2	10.4	9.4	8.2							
1470	CFM	3654	3556	3340	3102	2813	2423						
	BHP	0.5	0.54	0.6	0.67	0.72	0.75						
	Sones	14.0	13.6	12.9	12.2	11.4	10.5						
1615	CFM	4033	3944	3751	3543	3312	3033	2678	2177				
	BHP	0.66	0.7	0.77	0.85	0.91	0.96	0.99	0.99				
	Sones	15.8	15.5	14.8	14.2	13.4	12.8	12.0	11.4				
1850	CFM	4643	4566	4404	4232	4047	3851	3619	3348	3018	2593		
	BHP	0.97	1.02	1.11	1.19	1.28	1.36	1.41	1.46	1.49	1.49		
	Sones	19.6	19.3	18.6	17.9	17.2	16.4	15.8	15.3	14.8	14.2		
2030	CFM	5110	5039	4896	4740	4582	4408	4231	4018	3787	3524	3180	
	BHP	1.28	1.33	1.43	1.52	1.61	1.7	1.79	1.85	1.91	1.95	1.97	
	Sones	23	23	22	21	20	19.7	19.0	18.4	18.1	17.7	17.2	
2207	CFM	5567	5502	5373	5232	5088	4938	4778	4617	4422	4227	3986	3398
	BHP	1.63	1.69	1.8	1.9	2	2.1	2.2	2.3	2.36	2.43	2.48	2.53
	Sones	26	26	25	24	24	23	22	22	21	21	20	19.3

MAX Bhp AT A GIVEN RPM =  $(rpm/1617)^3$   
 MAXIMUM RPM = 2207  
 TIP SPEED (ft/min) =  $rpm \times 4.78$   
 MAX NEMA MOTOR FRAME SIZE = 184T  
 OUTLET VELOCITY (ft/min) =  $cfm/2.32$

Performance certified is for installation type B: Free inlet, Ducted outlet. Power rating (Bhp) does not include transmission losses.  
 Performance ratings do not include the effects of appurtenances (accessories).  
 The sound ratings shown are loudness values in fan sones at 1.5 m (5 feet) in a hemispherical free field calculated per AMCA International Standard 301.  
 Values shown are for installation type B: free inlet hemispherical sone levels.

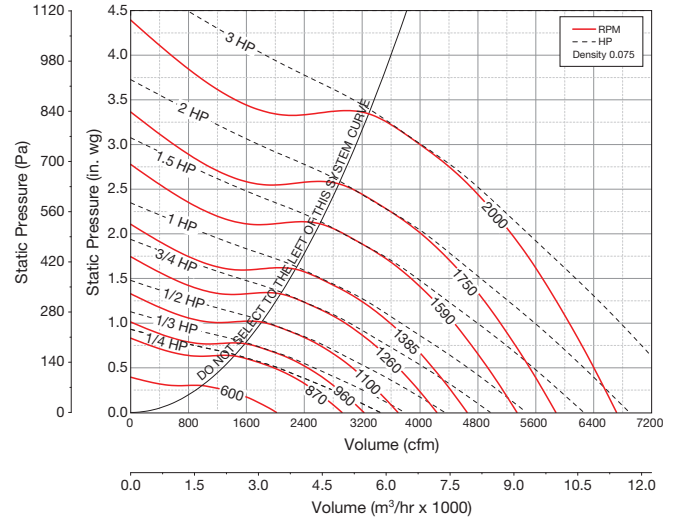
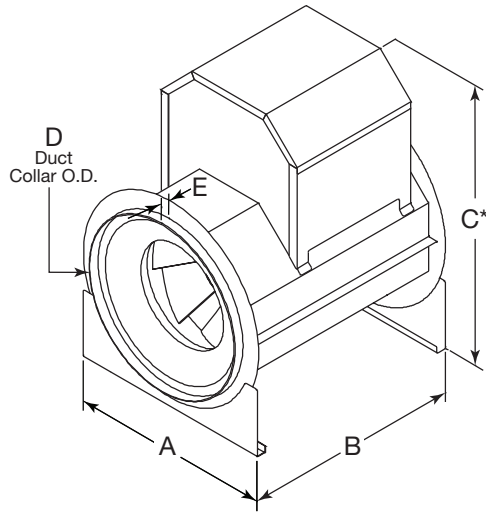

A	B	C*	D	E	Unit Weight (LMD) = 138 (63)	Dimensions shown in inches (millimeters). Weight shown in pounds (kilograms). *Motor cover is optional. Size may be greater depending on motor.
28 <sup>3</sup> / <sub>4</sub> (718)	31 <sup>1</sup> / <sub>8</sub> (791)	32 <sup>3</sup> / <sub>4</sub> (832)	17 <sup>1</sup> / <sub>2</sub> (445)	1 <sup>1</sup> / <sub>2</sub> (38)		

Fan RPM		CFM / Static Pressure in Inches wg											
		0.125	0.250	0.500	0.750	1.00	1.25	1.50	1.75	2.00	2.25	2.50	3.00
600	CFM	1731	1302										
	BHP	0.069	0.08										
	Sones	4.5	3.9										
750	CFM	2301	2047										
	BHP	0.12	0.14										
	Sones	6.0	5.7										
870	CFM	2738	2532	1978									
	BHP	0.18	0.21	0.24									
	Sones	7.3	6.9	6.4									
960	CFM	3060	2880	2443	1670								
	BHP	0.24	0.27	0.32	0.33								
	Sones	8.1	7.8	7.2	6.8								
1100	CFM	3552	3398	3061	2606	1854							
	BHP	0.34	0.38	0.45	0.49	0.49							
	Sones	9.7	9.4	8.8	8.4	8.2							
1260	CFM	4107	3979	3697	3373	2956	2336						
	BHP	0.5	0.54	0.62	0.69	0.73	0.74						
	Sones	11.5	11.3	10.6	10.0	10.0	9.9						
1385	CFM	4538	4425	4175	3902	3580	3178	2600					
	BHP	0.66	0.71	0.79	0.87	0.94	0.98	0.99					
	Sones	13.3	13.0	12.3	11.7	11.3	11.5	11.6					
1590	CFM	5241	5142	4932	4711	4468	4190	3866	3463	2922			
	BHP	0.98	1.03	1.13	1.23	1.33	1.4	1.46	1.49	1.49			
	Sones	16.3	16.0	15.4	14.8	14.2	13.7	13.8	14.0	13.8			
1750	CFM	5787	5698	5512	5314	5104	4883	4627	4344	4010	3574	3026	
	BHP	1.3	1.35	1.47	1.58	1.68	1.79	1.87	1.93	1.97	2	1.98	
	Sones	18.7	18.4	17.9	17.3	16.7	16.0	15.5	15.5	15.6	15.6	15.6	
2000	CFM	6638	6560	6403	6232	6059	5877	5683	5485	5249	5006	4714	3987
	BHP	1.92	1.98	2.11	2.24	2.36	2.48	2.6	2.72	2.8	2.87	2.92	2.98
	Sones	23	23	22	22	21	21	20	19.6	19.2	19.1	19.0	18.6

MAX Bhp AT A GIVEN RPM = (rpm/1388)<sup>3</sup>  
 MAXIMUM RPM = 2010  
 TIP SPEED (ft/min) = rpm x 5.24  
 MAX NEMA MOTOR FRAME SIZE = 184T  
 OUTLET VELOCITY (ft/min) = cfm/2.79

Performance certified is for installation type B: Free inlet, Ducted outlet. Power rating (Bhp) does not include transmission losses.  
 Performance ratings do not include the effects of appurtenances (accessories).  
 The sound ratings shown are loudness values in fan sones at 1.5 m (5 feet) in a hemispherical free field calculated per AMCA International Standard 301.  
 Values shown are for installation type B: free inlet hemispherical sone levels.

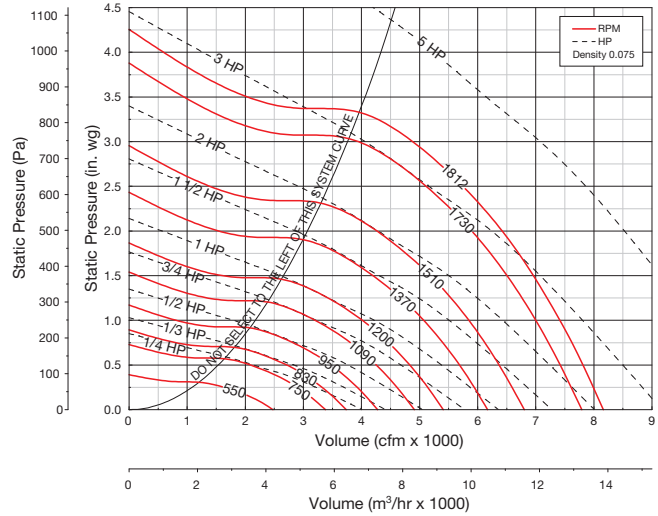
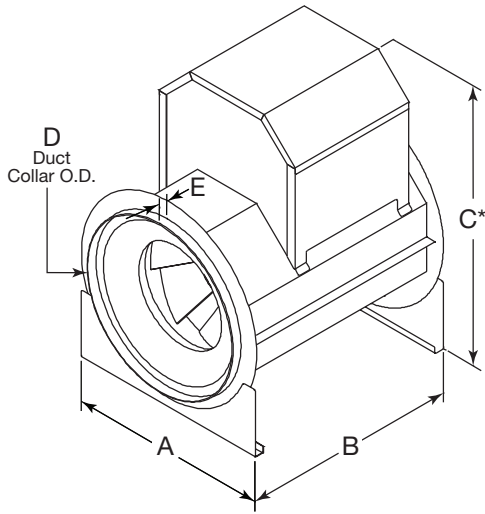

A	B	C*	D	E	Unit Weight (LMD) = 190 (86)	Dimensions shown in inches (millimeters). Weight shown in pounds (kilograms). *Motor cover is optional. Size may be greater depending on motor.
30 <sup>7</sup> / <sub>8</sub> (784)	33 <sup>3</sup> / <sub>8</sub> (841)	42 <sup>5</sup> / <sub>8</sub> (1083)	25 <sup>5</sup> / <sub>8</sub> (651)	1 <sup>1</sup> / <sub>2</sub> (38)		

Fan RPM		CFM / Static Pressure in Inches wg											
		0.125	0.250	0.500	0.750	1.00	1.25	1.50	1.75	2.00	2.25	2.50	3.00
550	CFM	2152	1637										
	BHP	0.08	0.095										
	Sones	4.0	3.6										
750	CFM	3158	2893	2075									
	BHP	0.18	0.2	0.24									
	Sones	6.6	6.1	5.4									
830	CFM	3544	3318	2703									
	BHP	0.24	0.27	0.32									
	Sones	7.9	7.3	6.5									
950	CFM	4109	3921	3472	2813								
	BHP	0.34	0.38	0.44	0.49								
	Sones	9.7	9.0	8.1	7.6								
1090	CFM	4762	4609	4251	3800	3189							
	BHP	0.51	0.55	0.62	0.69	0.74							
	Sones	12.4	11.8	10.4	9.7	9.6							
1200	CFM	5271	5136	4825	4464	4009	3404						
	BHP	0.66	0.71	0.8	0.87	0.94	0.99						
	Sones	14.0	13.4	12.2	11.1	10.7	10.5						
1370	CFM	6054	5936	5676	5395	5067	4673	4195	3591				
	BHP	0.97	1.03	1.13	1.22	1.31	1.39	1.47	1.49				
	Sones	16.6	16.1	15.1	14.2	13.2	12.8	12.5	12.0				
1510	CFM	6695	6588	6364	6114	5841	5537	5177	4751	4238	3521		
	BHP	1.29	1.35	1.47	1.57	1.67	1.76	1.85	1.94	1.98	1.96		
	Sones	19.9	19.3	18.1	17.0	16.1	15.1	14.7	14.4	14.1	13.8		
1730	CFM	7700	7606	7420	7209	6991	6757	6497	6207	5893	5515	5098	3887
	BHP	1.91	1.98	2.13	2.25	2.37	2.48	2.59	2.69	2.8	2.89	2.97	2.93
	Sones	26	26	24	23	22	21	19.8	18.9	18.5	18.0	17.5	17.5
1812	CFM	8073	7984	7806	7612	7403	7194	6949	6701	6405	6097	5730	4863
	BHP	2.19	2.26	2.41	2.55	2.67	2.79	2.91	3.02	3.13	3.24	3.34	3.43
	Sones	29	28	27	25	24	23	22	21	20	19.9	19.3	18.1

MAX Bhp AT A GIVEN RPM = (rpm/1199)<sup>3</sup>  
 MAXIMUM RPM = 1812  
 TIP SPEED (ft/min) = rpm x 5.83  
 MAX NEMA MOTOR FRAME SIZE = 184T  
 OUTLET VELOCITY (ft/min) = cfm/3.45

Performance certified is for installation type B: Free inlet, Ducted outlet. Power rating (Bhp) does not include transmission losses.  
 Performance ratings do not include the effects of appurtenances (accessories).  
 The sound ratings shown are loudness values in fan sones at 1.5 m (5 feet) in a hemispherical free field calculated per AMCA International Standard 301.  
 Values shown are for installation type B: free inlet hemispherical sone levels.

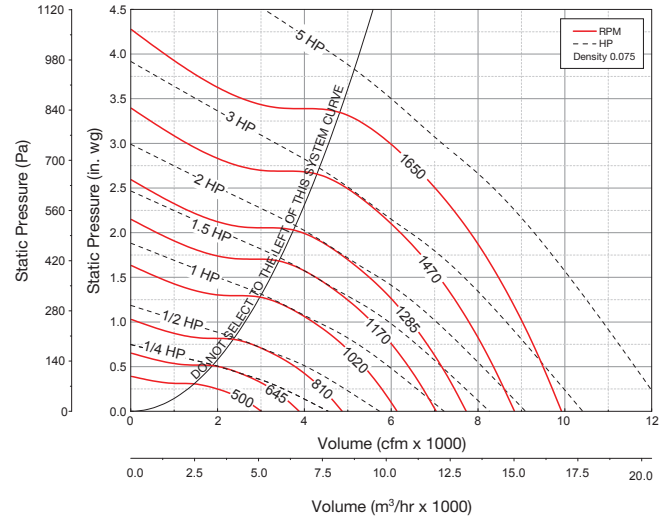
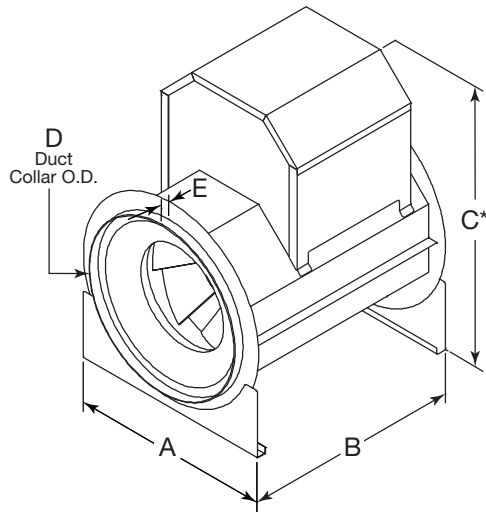

A	B	C*	D	E	Unit Weight (LMD) = 248 (112)	Dimensions shown in inches (millimeters). Weight shown in pounds (kilograms). *Motor cover is optional. Size may be greater depending on motor.
32 <sup>7</sup> / <sub>8</sub> (835)	35 <sup>3</sup> / <sub>4</sub> (908)	47 (1194)	28 (711)	1 <sup>3</sup> / <sub>8</sub> (35)		

Fan RPM		CFM / Static Pressure in Inches wg											
		0.125	0.250	0.500	0.750	1.00	1.25	1.50	1.75	2.00	2.25	2.50	3.00
500	CFM	2614	1991										
	BHP	0.097	0.12										
	Sones	4.6	4.2										
645	CFM	3592	3243	1988									
	BHP	0.19	0.22	0.25									
	Sones	6.2	5.8	5.2									
710	CFM	4016	3717	2848									
	BHP	0.25	0.28	0.33									
	Sones	7.1	6.8	6.1									
810	CFM	4652	4402	3778	2781								
	BHP	0.35	0.39	0.46	0.5								
	Sones	9.0	8.7	8.2	7.5								
925	CFM	5371	5164	4681	4033	3034							
	BHP	0.51	0.55	0.63	0.71	0.73							
	Sones	11.9	11.7	11.3	10.6	9.7							
1020	CFM	5960	5783	5371	4858	4193	3146						
	BHP	0.67	0.72	0.82	0.9	0.97	0.97						
	Sones	13.1	12.9	12.5	11.9	11.1	10.9						
1170	CFM	6885	6733	6390	6005	5546	4975	4244					
	BHP	0.99	1.05	1.16	1.26	1.36	1.45	1.5					
	Sones	15.6	15.3	14.8	14.2	13.6	12.8	11.8					
1285	CFM	7590	7451	7152	6827	6449	6009	5482	4832	3888			
	BHP	1.3	1.37	1.5	1.61	1.71	1.81	1.91	1.97	1.94			
	Sones	17.9	17.6	16.9	16.1	15.4	14.7	14.2	13.6	14.3			
1470	CFM	8720	8599	8356	8073	7789	7456	7096	6689	6197	5629	4926	
	BHP	1.92	2	2.16	2.29	2.42	2.54	2.65	2.77	2.88	2.95	2.96	
	Sones	22	22	21	20	19.4	18.5	17.6	17.4	17.1	16.8	16.7	
1650	CFM	9815	9708	9492	9258	9006	8753	8459	8160	7805	7438	6991	5948
	BHP	2.69	2.78	2.96	3.12	3.27	3.42	3.55	3.68	3.81	3.94	4.07	4.2
	Sones	27	27	26	25	24	23	23	22	21	21	21	21

MAX Bhp AT A GIVEN RPM = (rpm/1022)<sup>3</sup>  
 MAXIMUM RPM = 1650  
 TIP SPEED (ft/min) = rpm x 6.41  
 MAX NEMA MOTOR FRAME SIZE = 215T  
 OUTLET VELOCITY (ft/min) = cfm/4.14

Performance certified is for installation type B: Free inlet, Ducted outlet. Power rating (Bhp) does not include transmission losses.  
 Performance ratings do not include the effects of appurtenances (accessories).  
 The sound ratings shown are loudness values in fan sones at 1.5 m (5 feet) in a hemispherical free field calculated per AMCA International Standard 301.  
 Values shown are for installation type B: free inlet hemispherical sone levels.

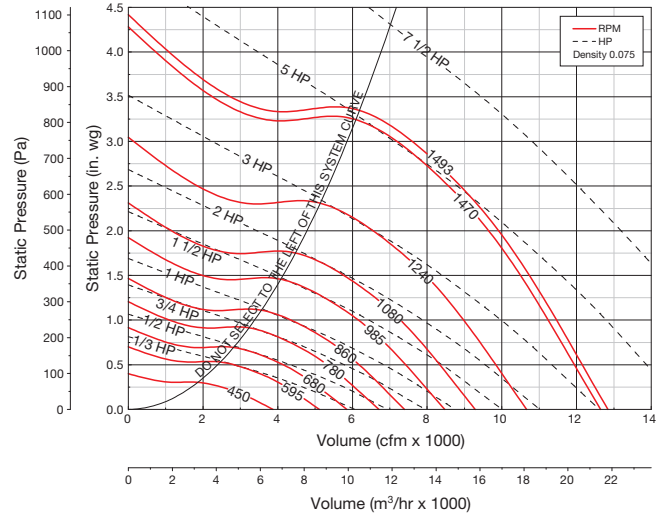
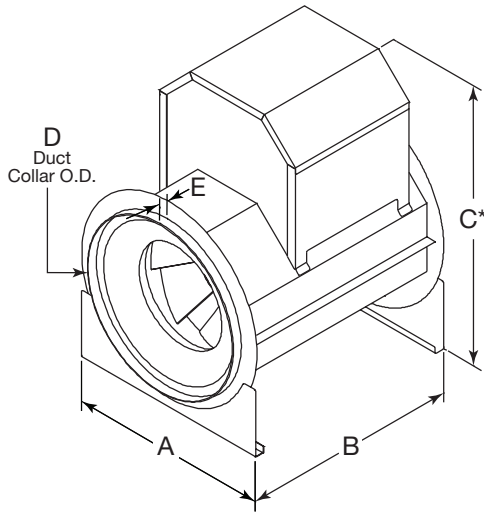

A	B	C*	D	E	Unit Weight (LMD) = 246 (112)	Dimensions shown in inches (millimeters). Weight shown in pounds (kilograms). *Motor cover is optional. Size may be greater depending on motor.
36 <sup>3</sup> / <sub>8</sub> (924)	39 <sup>1</sup> / <sub>4</sub> (997)	49 <sup>7</sup> / <sub>8</sub> (1267)	31 <sup>1</sup> / <sub>4</sub> (794)	1 <sup>3</sup> / <sub>8</sub> (35)		

Fan RPM		CFM / Static Pressure in Inches wg											
		0.125	0.250	0.500	0.750	1.00	1.25	1.50	1.75	2.00	2.25	2.50	3.00
450	CFM	3288	2485										
	BHP	0.12	0.14										
	Sones	5.4	5.2										
595	CFM	4686	4232	2836									
	BHP	0.24	0.28	0.33									
	Sones	7.2	6.8	6.1									
680	CFM	5471	5081	4127									
	BHP	0.34	0.39	0.47									
	Sones	8.9	8.1	7.4									
780	CFM	6379	6049	5319	4313								
	BHP	0.5	0.55	0.66	0.74								
	Sones	10.7	10.0	8.9	8.3								
860	CFM	7098	6799	6173	5409	4319							
	BHP	0.66	0.72	0.84	0.94	1							
	Sones	12.5	11.8	10.5	9.8	9.1							
985	CFM	8211	7950	7415	6840	6141	5214						
	BHP	0.98	1.04	1.17	1.31	1.42	1.49						
	Sones	15.1	14.4	13.1	12.4	11.6	10.8						
1080	CFM	9051	8813	8334	7830	7267	6588	5728					
	BHP	1.27	1.34	1.48	1.63	1.77	1.89	1.97					
	Sones	17.0	16.4	15.1	14.1	13.3	12.7	12.0					
1175	CFM	9888	9668	9231	8774	8307	7761	7111	6324	5248			
	BHP	1.62	1.7	1.85	2.01	2.18	2.32	2.44	2.52	2.53			
	Sones	19.5	18.7	17.4	16.2	15.3	14.7	14.2	13.6	13.4			
1240	CFM	10458	10250	9836	9409	8970	8484	7955	7294	6498	5388		
	BHP	1.9	1.98	2.14	2.3	2.48	2.64	2.79	2.9	2.98	2.95		
	Sones	22	21	19.6	18.1	17.0	16.0	15.6	15.1	14.6	14.4		
1470	CFM	12469	12294	11944	11594	11234	10864	10493	10070	9633	9114	8557	7156
	BHP	3.12	3.22	3.41	3.6	3.79	4	4.21	4.4	4.57	4.72	4.86	5.02
	Sones	31	30	28	26	24	23	22	21	20	19.9	19.5	19.2
1493	CFM	12669	12497	12152	11808	11456	11091	10727	10322	9892	9412	8863	7538
	BHP	3.27	3.37	3.56	3.75	3.95	4.16	4.37	4.57	4.75	4.91	5.05	5.23
	Sones	32	31	28	27	25	23	22	21	21	21	20	19.7

MAX Bhp AT A GIVEN RPM = (rpm/857)<sup>3</sup>  
 MAXIMUM RPM = 1493  
 TIP SPEED (ft/min) = rpm x 7.07  
 MAX NEMA MOTOR FRAME SIZE = 215T  
 OUTLET VELOCITY (ft/min) = cfm/5.12

Performance certified is for installation type B: Free inlet, Ducted outlet. Power rating (Bhp) does not include transmission losses. Performance ratings do not include the effects of appurtenances (accessories). The sound ratings shown are loudness values in fan sones at 1.5 m (5 feet) in a hemispherical free field calculated per AMCA International Standard 301. Values shown are for installation type B: free inlet hemispherical sone levels.



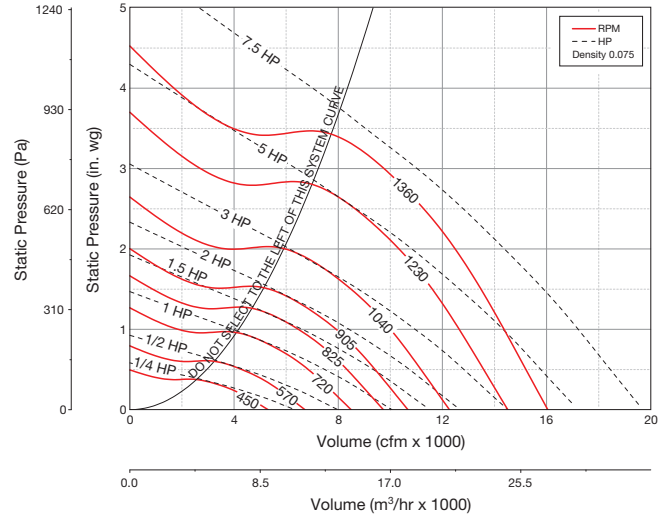
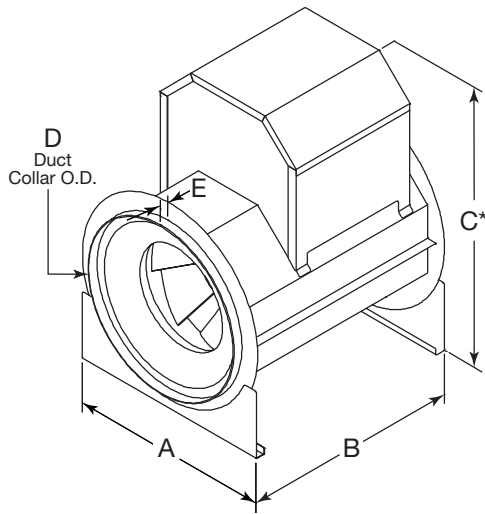

<b>A</b>	<b>B</b>	<b>C*</b>	<b>D</b>	<b>E</b>	Unit Weight (LMD) = 304 (138)	Dimensions shown in inches (millimeters). Weight shown in pounds (kilograms). *Motor cover is optional. Size may be greater depending on motor.
40 (1016)	42 3/8 (1083)	53 1/4 (1353)	34 1/4 (870)	1 3/8 (35)		

Fan RPM		CFM / Static Pressure in Inches wg											
		0.125	0.250	0.500	0.750	1.00	1.25	1.50	1.75	2.00	2.25	2.50	3.00
450	CFM	4668	4068										
	BHP	0.19	0.23										
	Sones	5.6	5.4										
500	CFM	5329	4778										
	BHP	0.25	0.29										
	Sones	6.4	6.1										
570	CFM	6225	5703	4280									
	BHP	0.35	0.4	0.49									
	Sones	8	7.3	6.7									
655	CFM	7292	6850	6100	4260								
	BHP	0.51	0.57	0.69	0.75								
	Sones	10.2	9.4	8.3	7.9								
720	CFM	8098	7703	6918	5725								
	BHP	0.67	0.73	0.87	0.97								
	Sones	12.3	11.4	10.1	9.0								
825	CFM	9387	9042	8324	7760	6465	4691						
	BHP	0.98	1.05	1.21	1.35	1.47	1.45						
	Sones	14.8	14.0	12.6	11.7	10.5	10.1						
905	CFM	10361	10047	9403	8761	8244	6849	5189					
	BHP	1.28	1.36	1.52	1.7	1.84	1.95	1.92					
	Sones	17.1	16.3	14.7	13.6	13.0	11.7	12.1					
1040	CFM	11995	11721	11174	10597	10054	9701	8589	7421				
	BHP	1.91	2.01	2.18	2.38	2.58	2.75	2.89	2.98				
	Sones	21	21	19.1	17.7	16.6	16.1	15.0	13.9				
1230	CFM	14279	14047	13584	13121	12630	12137	11770	11471	10568	9535	8576	
	BHP	3.11	3.23	3.45	3.66	3.9	4.13	4.35	4.56	4.72	4.86	4.95	
	Sones	28	27	26	24	23	22	21	21	19.9	19.1	18.6	
1360	CFM	15835	15625	15206	14787	14361	13916	13470	13105	12834	12420	11478	9678
	BHP	4.18	4.31	4.55	4.79	5.03	5.29	5.56	5.81	6.03	6.25	6.42	6.67
	Sones	33	33	31	29	28	27	26	25	24	24	24	23

MAX Bhp AT A GIVEN RPM = (rpm/719)<sup>3</sup>  
 MAXIMUM RPM = 1360  
 TIP SPEED (ft/min) = rpm x 7.85  
 MAX NEMA MOTOR FRAME SIZE = 215T  
 OUTLET VELOCITY (ft/min) = cfm/6.21

Performance certified is for installation type B: Free inlet, Ducted outlet. Power rating (Bhp) does not include transmission losses.  
 Performance ratings do not include the effects of appurtenances (accessories).  
 The sound ratings shown are loudness values in fan sones at 1.5 m (5 feet) in a hemispherical free field calculated per AMCA International Standard 301.  
 Values shown are for installation type B: free inlet hemispherical sone levels.

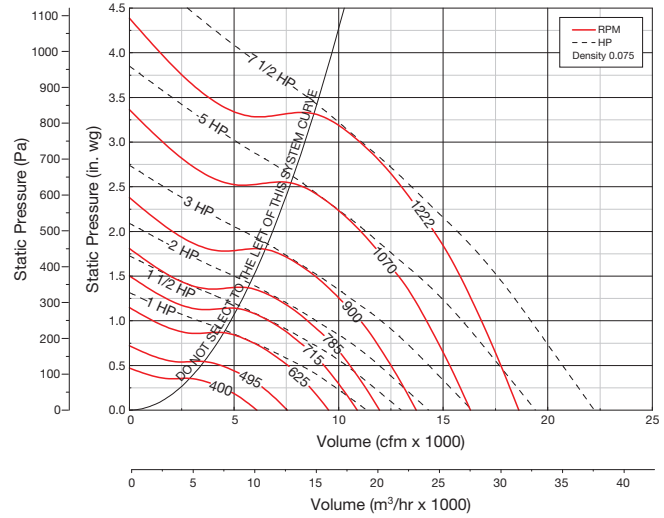
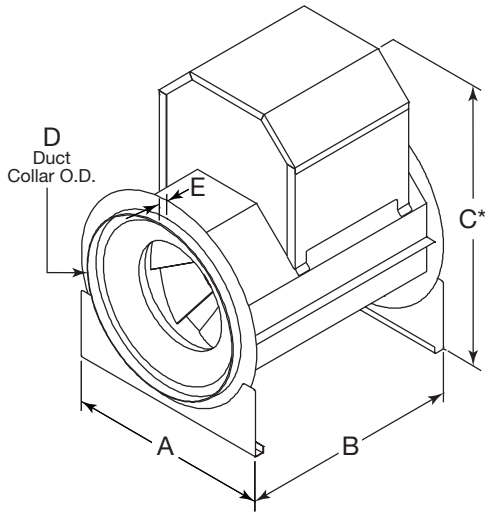

A	B	C*	D	E	Unit Weight (LMD) = 374 (170)	Dimensions shown in inches (millimeters). Weight shown in pounds (kilograms). *Motor cover is optional. Size may be greater depending on motor.
42 <sup>7</sup> / <sub>8</sub> (1089)	45 <sup>1</sup> / <sub>8</sub> (1146)	58 (1473)	37 <sup>3</sup> / <sub>4</sub> (959)	1 <sup>3</sup> / <sub>8</sub> (35)		

Fan RPM		CFM / Static Pressure in Inches wg											
		0.125	0.250	0.500	0.750	1.00	1.25	1.50	1.75	2.00	2.25	2.50	3.00
400	CFM	5400	4425										
	BHP	0.2	0.25										
	Sones	6.0	5.4										
495	CFM	6996	6371	4360									
	BHP	0.36	0.41	0.49									
	Sones	7.8	7.3	6.3									
625	CFM	9098	8644	7557	5911								
	BHP	0.67	0.74	0.89	0.99								
	Sones	11.3	10.8	9.5	8.5								
715	CFM	10522	10141	9282	8179	6629							
	BHP	0.98	1.07	1.23	1.39	1.48							
	Sones	14.9	14.2	12.9	11.8	11.1							
785	CFM	11621	11285	10535	9664	8498	6984						
	BHP	1.27	1.37	1.55	1.74	1.89	1.97						
	Sones	17.6	16.9	15.4	14.2	13.5	12.9						
900	CFM	13416	13123	12495	11807	11025	10025	8830	6979				
	BHP	1.88	2	2.21	2.42	2.63	2.81	2.93	2.9				
	Sones	21	20	19.1	17.8	16.7	16.1	15.4	14.5				
950	CFM	14193	13915	13329	12700	12008	11140	10137	8892	6903			
	BHP	2.19	2.32	2.55	2.77	3	3.21	3.37	3.47	3.37			
	Sones	23	22	21	19.6	18.4	17.6	16.9	16.3	15.9			
1025	CFM	15355	15098	14569	13999	13377	12716	11867	10923	9782	8118		
	BHP	2.73	2.87	3.13	3.36	3.6	3.85	4.07	4.24	4.35	4.3		
	Sones	25	25	24	22	21	20	19.4	18.8	18.0	18.0		
1070	CFM	16051	15805	15306	14760	14185	13570	12826	11981	11060	9870	8080	
	BHP	3.1	3.24	3.51	3.75	4	4.27	4.5	4.71	4.88	4.97	4.84	
	Sones	27	27	25	24	23	22	21	20	19.7	18.9	19.8	
1150	CFM	17287	17058	16599	16100	15592	15029	14456	13732	12950	12093	11053	
	BHP	3.82	3.97	4.27	4.54	4.8	5.08	5.36	5.61	5.84	6.02	6.14	
	Sones	30	29	28	27	26	25	24	23	22	22	21	
1222	CFM	18397	18182	17750	17294	16815	16317	15779	15236	14524	13788	12981	10995
	BHP	4.57	4.72	5.04	5.34	5.61	5.9	6.2	6.5	6.75	7	7.19	7.43
	Sones	33	33	31	30	29	28	27	26	25	24	24	23

MAX Bhp AT A GIVEN RPM = (rpm/626)<sup>3</sup>  
 MAXIMUM RPM = 1222  
 TIP SPEED (ft/min) = rpm x 8.64  
 MAX NEMA MOTOR FRAME SIZE = 215T  
 OUTLET VELOCITY (ft/min) = cfm/7.54

Performance certified is for installation type B: Free inlet, Ducted outlet. Power rating (Bhp) does not include transmission losses.  
 Performance ratings do not include the effects of appurtenances (accessories).  
 The sound ratings shown are loudness values in fan sones at 1.5 m (5 feet) in a hemispherical free field calculated per AMCA International Standard 301.  
 Values shown are for installation type B: free inlet hemispherical sone levels.

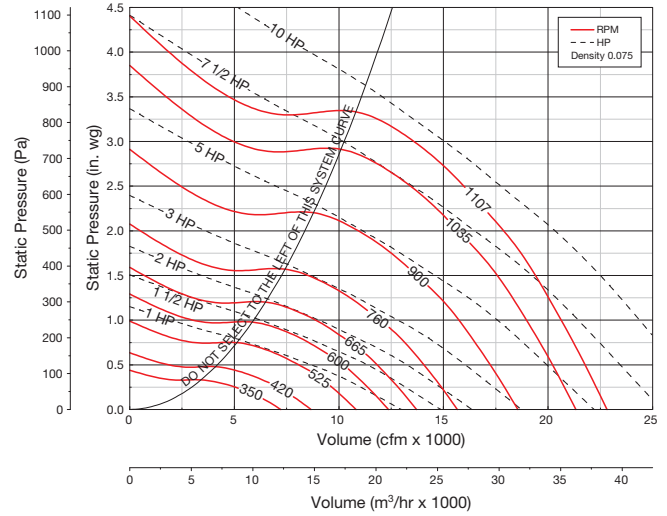
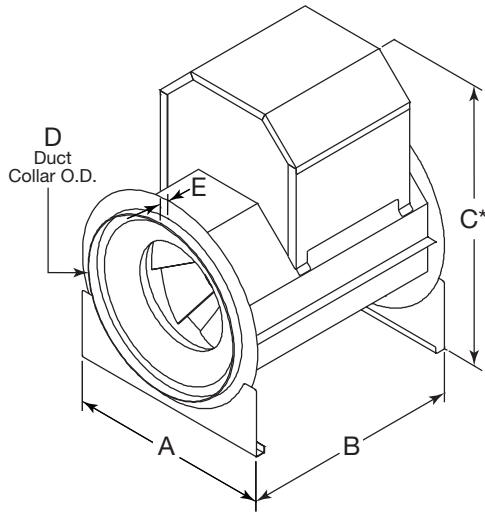

<b>A</b>	<b>B</b>	<b>C*</b>	<b>D</b>	<b>E</b>	Unit Weight (LMD) = 504 (229)	Dimensions shown in inches (millimeters). Weight shown in pounds (kilograms). *Motor cover is optional. Size may be greater depending on motor.
48 (1219)	52 1/4 (1327)	63 7/8 (1622)	42 (1067)	1 7/8 (48)		

Fan RPM		CFM / Static Pressure in Inches wg												
		0.125	0.250	0.500	0.750	1.00	1.25	1.50	1.75	2.00	2.25	2.50	3.00	
350	CFM	6328	5043											
	BHP	0.23	0.28											
	Sones	5.1	4.5											
420	CFM	7941	7109											
	BHP	0.37	0.43											
	Sones	6.8	6.1											
525	CFM	10266	9656	8082										
	BHP	0.67	0.75	0.91										
	Sones	9.7	9.1	8.1										
600	CFM	11881	11366	10204	8534									
	BHP	0.97	1.07	1.26	1.41									
	Sones	11.7	11.1	10.1	9.1									
665	CFM	13269	12820	11809	10548	8847								
	BHP	1.29	1.41	1.61	1.82	1.96								
	Sones	14.7	13.8	12.2	11.1	10.3								
700	CFM	14012	13595	12655	11550	10086	7974							
	BHP	1.49	1.62	1.83	2.06	2.23	2.29							
	Sones	16.7	15.7	13.8	12.3	11.4	11							
760	CFM	15282	14898	14060	13125	11951	10534	8319						
	BHP	1.89	2.02	2.26	2.51	2.74	2.9	2.91						
	Sones	18.5	17.6	15.9	14.2	13.2	12.5	12.3						
900	CFM	18227	17903	17229	16509	15710	14806	13707	12493	10902				
	BHP	3.07	3.23	3.53	3.81	4.1	4.39	4.63	4.82	4.92				
	Sones	24	23	22	20	18.4	17.1	16.7	16.2	15.7				
950	CFM	19274	18968	18342	17660	16933	16168	15192	14108	12884	11355			
	BHP	3.59	3.76	4.09	4.38	4.68	5	5.28	5.51	5.69	5.79			
	Sones	26	26	24	22	21	19.3	18.5	18.1	17.7	17.2			
1035	CFM	21052	20770	20207	19591	18965	18271	17568	16665	15695	14645	13339		
	BHP	4.61	4.8	5.16	5.48	5.8	6.14	6.48	6.79	7.06	7.28	7.42		
	Sones	30	29	27	26	24	23	22	21	20	19.8	19.3		
1107	CFM	22554	22291	21764	21207	20622	20014	19358	18701	17831	16936	15954	13542	
	BHP	5.62	5.81	6.2	6.56	6.9	7.25	7.62	7.98	8.3	8.6	8.84	9.14	
	Sones	33	32	30	29	27	26	25	24	23	22	22	21	

MAX Bhp AT A GIVEN RPM = (rpm/528)<sup>3</sup>  
 MAXIMUM RPM = 1107  
 TIP SPEED (ft/min) = rpm x 9.56  
 MAX NEMA MOTOR FRAME SIZE = 254T  
 OUTLET VELOCITY (ft/min) = cfm/9.31

Performance certified is for installation type B: Free inlet, Ducted outlet. Power rating (Bhp) does not include transmission losses.  
 Performance ratings do not include the effects of appurtenances (accessories).  
 The sound ratings shown are loudness values in fan sones at 1.5 m (5 feet) in a hemispherical free field calculated per AMCA International Standard 301.  
 Values shown are for installation type B: free inlet hemispherical sone levels.

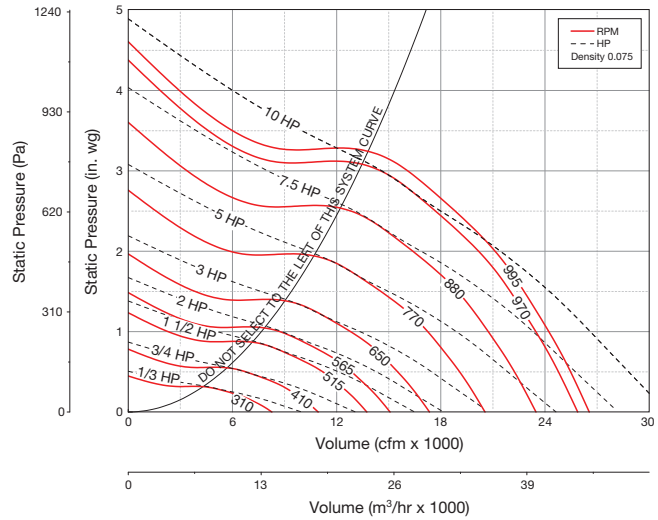
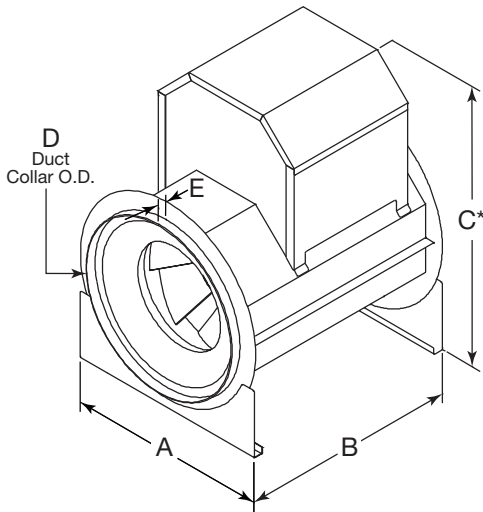

A	B	C*	D	E	Unit Weight (LMD) = 524 (238)	Dimensions shown in inches (millimeters). Weight shown in pounds (kilograms). *Motor cover is optional. Size may be greater depending on motor.
52½ (1334)	56⅞ (1428)	68½ (1740)	46⅞ (1172)	1⅞ (48)		

Fan RPM		CFM / Static Pressure in Inches wg											
		0.125	0.250	0.500	0.750	1.00	1.25	1.50	1.75	2.00	2.25	2.50	3.00
310	CFM	7292	5734										
	BHP	0.26	0.32										
	Sones	5.5	5.3										
355	CFM	8648	7562										
	BHP	0.37	0.44										
	Sones	6.6	6.3										
410	CFM	10258	9414	6729									
	BHP	0.54	0.62	0.75									
	Sones	8.1	7.8	7.0									
450	CFM	11399	10672	8625									
	BHP	0.69	0.78	0.96									
	Sones	9.1	8.9	8.2									
515	CFM	13210	12613	11178	8911								
	BHP	1	1.11	1.33	1.49								
	Sones	11.4	11.1	10.3	9.6								
565	CFM	14591	14077	12838	11173	8729							
	BHP	1.29	1.42	1.66	1.87	1.98							
	Sones	13.7	13.3	12.4	11.5	12.1							
650	CFM	16923	16502	15503	14361	12796	10730						
	BHP	1.91	2.07	2.34	2.62	2.86	3						
	Sones	17.7	17.3	16.2	15.3	14.4	13.5						
770	CFM	20190	19835	19061	18194	17217	16007	14521	12744				
	BHP	3.09	3.29	3.64	3.95	4.29	4.59	4.84	4.99				
	Sones	24	23	22	21	20	19.4	18.8	18.0				
880	CFM	23170	22859	22237	21492	20724	19869	18914	17746	16360	14811	12331	
	BHP	4.55	4.77	5.22	5.58	5.93	6.32	6.68	6.99	7.26	7.44	7.27	
	Sones	28	27	26	25	24	23	22	21	21	20	27	
970	CFM	25600	25318	24754	24131	23447	22735	21959	21155	20096	18975	17667	14216
	BHP	6.04	6.29	6.78	7.22	7.61	8	8.43	8.85	9.19	9.52	9.81	9.86
	Sones	32	31	30	29	28	27	26	25	24	23	23	32

MAX Bhp AT A GIVEN RPM = (rpm/451)<sup>3</sup>  
 MAXIMUM RPM = 995  
 TIP SPEED (ft/min) = rpm x 10.54  
 MAX NEMA MOTOR FRAME SIZE = 254T  
 OUTLET VELOCITY (ft/min) = cfm/11.27

Performance certified is for installation type B: Free inlet, Ducted outlet. Power rating (Bhp) does not include transmission losses.

Performance ratings do not include the effects of appurtenances (accessories).

The sound ratings shown are loudness values in fan sones at 1.5 m (5 feet) in a hemispherical free field calculated per AMCA International Standard 301.

Values shown are for installation type B: free inlet hemispherical sone levels.



## Model EQD

Duct mounted supply, exhaust or return fans shall be of mixed flow direct-driven inline type. The fan housing shall be constructed of galvanized steel in an octagonal design and shall include removable duct collars for slip-fit connection to ductwork as standard.

The fan wheel shall be a fully welded mixed flow wheel, constructed of aluminum and shall include a wheel cone carefully matched to the inlet cone for precise running tolerances. Wheels shall be statically and dynamically balanced.

Fan construction shall include a universal mounting system allowing for mounting of the fan in hanging, wall, 45 degree increments, and base-mounted horizontal configurations. The EQD shall have integrated lifting lugs as standard.

A NEMA-1 disconnect switch shall be provided as standard. Factory wiring shall be provided from the motor to the handy box.

Fan shall bear the AMCA Certified Ratings Seal for Sound and Air Performance.

Fan shall bear a permanently affixed manufacturer's nameplate containing the model number and individual serial number for future identification.

Fans shall be model EQD as manufactured by Greenheck Fan Corporation of Schofield, Wisconsin, USA.

**Note:** *The model EQD Mixed Flow Inline Fan is Patent Pending.*

## Model EQB

Duct mounted supply, exhaust or return fans shall be of belt-driven mixed flow inline type. The fan housing shall be constructed of galvanized steel in a structurally rigid, formed octagonal design and shall include removable duct collars for slip-fit connection to ductwork as standard.

Fan construction shall include a universal mounting system allowing for mounting of the fan in hanging and base-mounted horizontal configurations. Housing shall be field rotatable to adjust the position of the motor. Fans shall also include an OSHA compliant galvanized steel belt guard that encloses the motor pulley and belts.

The fan wheel shall be a fully welded mixed flow wheel, constructed of aluminum and shall include a wheel cone carefully matched to the inlet cone for precise running tolerances. Wheels shall be statically and dynamically balanced.

Motors shall be heavy-duty ball bearing type, carefully matched to the fan load and furnished at the specified voltage, phase and enclosure. Motors and drives shall be mounted out of the airstream, and motors shall be readily accessible for maintenance. Fans shall include an adjustable EZ-Tension System that allows belt tensioning operations to be performed without external support for the weight of the motor.

Precision ground and polished fan shafts shall be mounted in regreaseable pillow block ball bearings with extended lubrication lines to the exterior of the housing as standard. Bearings shall be selected for a minimum L<sub>10</sub> life in excess of 100,000 hours (L<sub>50</sub> average life in excess of 500,000 hours) at maximum cataloged operating speed.

Drives shall be sized for a minimum of 150% of driven horsepower. Pulleys shall be of the fully machined cast iron type, keyed and securely attached to the wheel and motor shafts. Motor pulleys shall be adjustable for system balancing.

A NEMA-1 disconnect switch shall be provided as standard. Factory wiring shall be provided from the motor to the handy box.

Fan shall bear the AMCA Certified Ratings Seal for Sound and Air Performance.

Fan shall bear a permanently affixed manufacturer's nameplate containing the model number and individual serial number for future identification.

Fans shall be model EQB as manufactured by Greenheck Fan Corporation of Schofield, Wisconsin, USA.

**Note:** *The model EQB Mixed Flow Inline Fan is Patent Pending.*

## Vari-Green® Motor

Motor to be an electronic commutation (EC) motor specifically designed for fan applications. AC induction type motors are not acceptable. Examples of unacceptable motors are: Shaded Pole, Permanent Split Capacitor (PSC), Split Phase, Capacitor Start and 3 phase induction type motors. Motors shall be permanently lubricated with heavy-duty ball bearings to match the fan load and prewired to the specific voltage and phase. Internal motor circuitry shall convert AC power supplied to the fan to DC power to operate the motor. Motor shall be speed controllable down to 20% of full speed (80% turndown). Speed shall be controlled by either a potentiometer dial mounted on the fan or by a 0-10 VDC signal. Motor shall be a minimum of 85% efficient at all speeds.



## Vari-Green® Controls Constant Pressure

Greenheck's Constant Pressure system shall be a complete package designed to regulate fan speed based on demand while maintaining a constant static pressure. System shall include fan with Vari-Green Motor, Vari-Green Constant Pressure control, transformer, and pressure tap. Vari-Green Constant Pressure control shall have the transducer integrated with a touch button control panel. Control shall have a run mode and a program mode preventing unwanted changes when in run mode. Transformer shall be factory-supplied to provide power to the Vari-Green Constant Pressure controller. System shall include a self-sealing aluminum pressure tube with ¼-inch connection. Fan shall be centrifugal direct drive type in upblast, downblast, or inline configuration with controllable EC Vari-Green motor.

## Remote Dial

Remote dial shall be a Vari-Green control specifically designed to provide 0-10 VDC signal to Greenheck's Vari-Green Motor.

## 2-Speed

2-Speed control shall be a Vari-Green Control specifically designed to allow the Vari-Green Motor to operate at two distinct speeds. 2-Speed Control shall include two dials that may be set at any point between 0 and 10 VDC and an integral transformer capable of reducing 115/230 volt AC power to 24 volt AC power.

# EQB Belt Drive

## Cost and Efficiency Comparison



Mixed flow fans are hybrid designs that combine the best axial and centrifugal properties into one fan. Model EQB offers better air and sound performance than axial and centrifugal inline fans and is priced to fill a gap in the current market offering of inline fans.

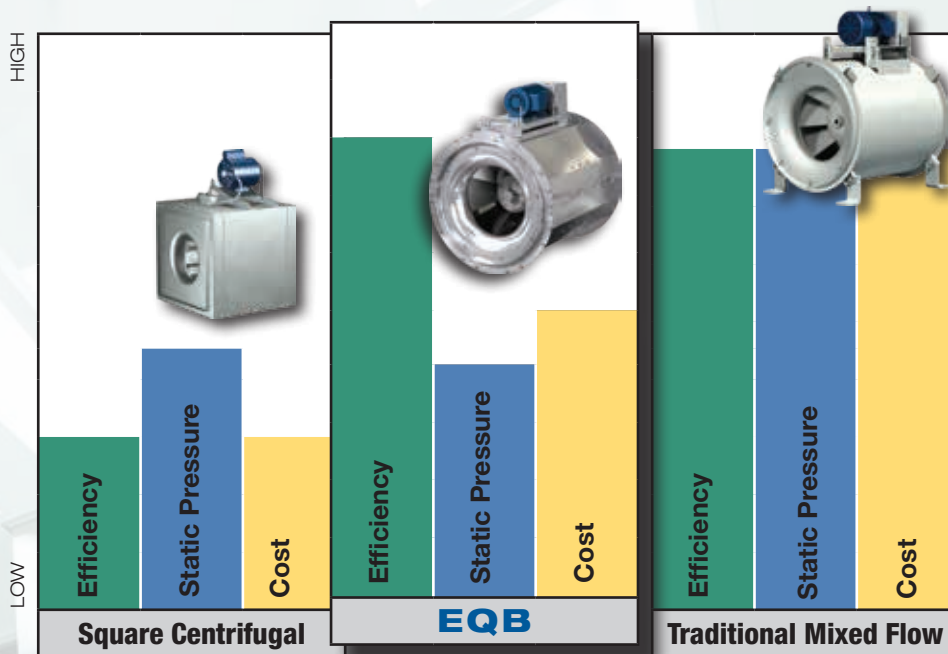

### Indoor, commercial, clean air applications include:

- Office Buildings • Educational Facilities • Libraries
- Hospitals • Concert Halls • Parking Garages

### Enjoy Greenheck’s extraordinary service, before, during and after the sale.

Greenheck offers added value to our wide selection of top performing, energy-efficient products by providing several unique Greenheck service programs.



- Our Quick Delivery Program ensures shipment of our in-stock products within 24 hours of placing your order. Our Quick Build made-to-order products can be produced in 1-3-5-10-15 or 25-day production cycles, depending upon their complexity.
- Greenheck’s free Computer Aided Product Selection program (CAPS), rated by many as the best in the industry, helps you conveniently and efficiently select the right products for the challenge at hand.
- Greenheck has been Green for a long time! Our energy-saving products and ongoing corporate commitment to sustainability can help you qualify for LEED credits.
- Our 3D service allows you to download, at no charge, easy-to-use AutoDesk® Revit® 3D drawings for many of our ventilation products.

Find out more about these special Greenheck services at [greenheck.com](http://greenheck.com)

# Quick Build Program

Model	Best Available Program
EQD	10 Days
EQB	10 Days

If the product you need is not in stock, and you still need it fast, Greenheck boasts the most comprehensive line of quick build products with 1, 3, 5, 10, 15, and 25 day quick build cycles available.

Models EQD and EQB are available with an expedited delivery of 10, 15 or 25 days on our Quick Build program. Performance capacities range from 550 to 23,000 cfm and up to 3 in. wg of static pressure.

Look to Greenheck to meet your ventilation needs as the leader in the air movement and control industry.



## Building Value in Air

Greenheck delivers value to mechanical engineers by helping them solve virtually any air quality challenges their clients face with a comprehensive selection of

top quality, innovative air-related equipment. We offer extra value to contractors by providing easy-to-install, competitively priced, reliable products that arrive on time.

And building owners and occupants value the energy efficiency, low maintenance and quiet dependable operation they experience long after the construction project ends.

## Our Commitment

*As a result of our commitment to continuous improvement, Greenheck reserves the right to change specifications without notice.*

Specific Greenheck product warranties are located on [greenheck.com](http://greenheck.com) within the product area tabs and in the Library under Warranties.



Prepared to Support Green Building Efforts

