

## Combination FIRE SMOKE DAMPERS

### APPLICATION

Model FSD-211 is a combination fire smoke damper with 3V style blades. The FSD-211 has been qualified to 2000 fpm (10.2 m/s) and 6 in. wg (1.5 kPa) for operation and dynamic closure in emergency fire smoke situations. Model FSD-211 may be installed vertically (with blades running horizontal) or horizontally and is rated for airflow and leakage in either direction.

### RATINGS

#### UL 555 Fire Resistance Rating

**Fire Rating:** 1½ Hours  
**Dynamic Closure Rating:** Actual limits are size dependent  
**Maximum Velocity:** 2000 fpm (10.2 m/s)  
**Maximum Pressure:** 6 in. wg (1.5 kPa)  
**Maximum Temperature:** 350°F (177°C) -- Depending on actuator

#### UL 555S Leakage Rating

**Leakage Class:** I  
**Operational Rating:** Actual limits are actuator dependent  
**Maximum Velocity:** 2000 fpm (10.2 m/s)  
**Maximum Pressure:** 6 in. wg (1.5 kPa)  
**Maximum Temperature:** 350°F (177°C) - Depending on actuator

**Steel 3-V Blades**  
**UL 555S Leakage Class I**  
**UL 555 1½ Hour Fire Resistance Rating**

Model FSD-211 meets the requirements for fire dampers, smoke dampers and combination fire smoke dampers established by:

**National Fire Protection Association**  
 NFPA Standards 80, 90A, 92A, 92B, 101 & 105  
**IBC International Building Codes**

**“UL CLASSIFIED (see complete marking on product)”**  
**“UL CLASSIFIED to Canadian safety standards (see complete marking on product)”**  
 Standard 555 & 555S (Listing #R13317)

Construction	Standard	Optional
Frame Material	Galvanized steel	-
Frame Material Thickness	16 ga. (1.5mm)	-
Frame Type	5 in. x 1 in. (127mm x 25mm) hat channel	-
Blade Material	Galvanized steel	-
Blade Material Thickness	16 ga. (1.5mm)	-
Blade Type	3V	-
Linkage	Plated steel out of airstream, concealed in jamb	-
Axle Bearings	304SS	-
Axle Material	Plated steel	-
Blade Seals	Silicone	-
Jamb Seals	304SS	-
Closure Device	RRL	RRL/OCI or Fusible Link
Closure Temperature	165°F (74°C)	212°F (100°C), 350°F (177°C)



FM Approvals  
 SPECIFICATION TESTED PRODUCT  
 (OPTION)

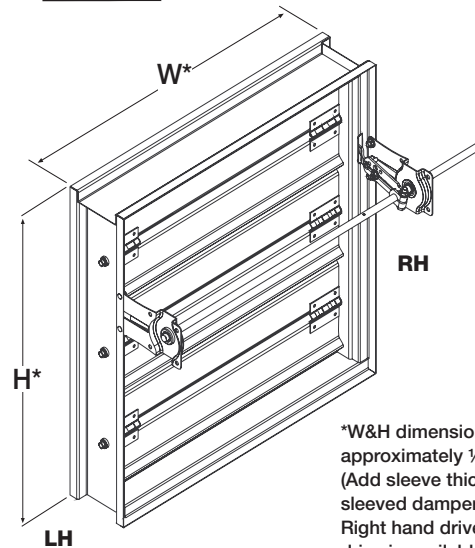

\*W&H dimensions furnished approximately ¼in. (6mm) undersize. (Add sleeve thickness for overall sleeved damper dimension)  
 Right hand drive is shown. Left hand drive is available upon request.

W x H	Minimum Size	Maximum Size		
		Single Section	Multiple Section	
			Horizontal	Vertical
<b>4 in. wg (1 kPa) pressure</b>				
Inches	8 x 6	32 x 50 or 36 x 48	100 x 96	100 x 96
mm	203 x 152	813 x 1270 or 914 x 1219	2540 x 2438	2540 x 2438
<b>6 in. wg (1.5 kPa) pressure</b>				
Inches	8 x 6	36 x 48	100 x 48	100 x 48
mm	203 x 152	914 x 1219	2540 x 1219	2540 x 1219

### FEATURES:

- Frames are constructed with reinforced corners. Low profile head and sill are used on sizes less than 17 in. high (432mm).
- Blades are reinforced with 3 longitudinal structurally designed vee's.

Installation instructions available at [www.greenheck.com](http://www.greenheck.com)

**Options available on FSD-211:**

- Actuators: 24V, 230V
- Factory mounted accessories
  - Retaining angles
- POC retaining angles
- RRL/OCI (Open closed indication switches)
- Transitions: R, C, B

**Pressure Drop Data**

This pressure drop testing was conducted in accordance with AMCA Standard 500-D using the three configurations shown. All data has been corrected to represent standard air at a density of .075 lb/ft<sup>3</sup> (1.201 kg/m<sup>3</sup>).

Actual pressure drop found in any HVAC system is a combination of many factors. This pressure drop information along with an analysis of other system influences should be used to estimate actual pressure losses for a damper installed in a given HVAC system.

**AMCA Test Figures**

**Figure 5.3** Illustrates a fully ducted damper. This configuration has the lowest pressure drop of the three test configurations because entrance and exit losses are minimized by straight duct runs upstream and downstream of the damper.

**Figure 5.2** Illustrates a ducted damper exhausting air into an open area. This configuration has a lower pressure drop than Figure 5.5 because entrance losses are minimized by a straight duct run upstream of the damper.

**Figure 5.5** Illustrates a plenum mounted damper. This configuration has the highest pressure drop because of extremely high entrance and exit losses due to the sudden changes of area in the system.

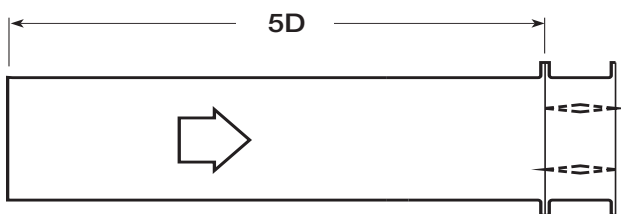
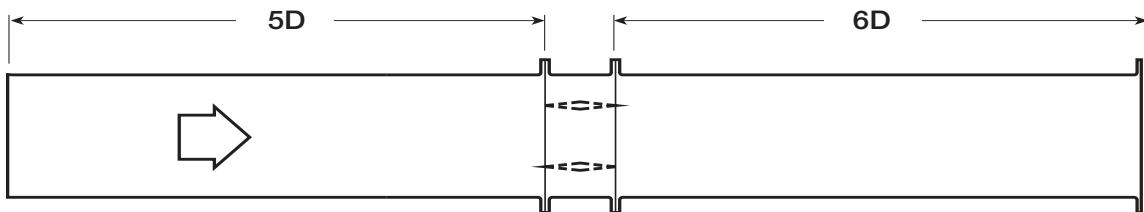

$$D = \sqrt{\frac{4(W)(H)}{3.14}}$$

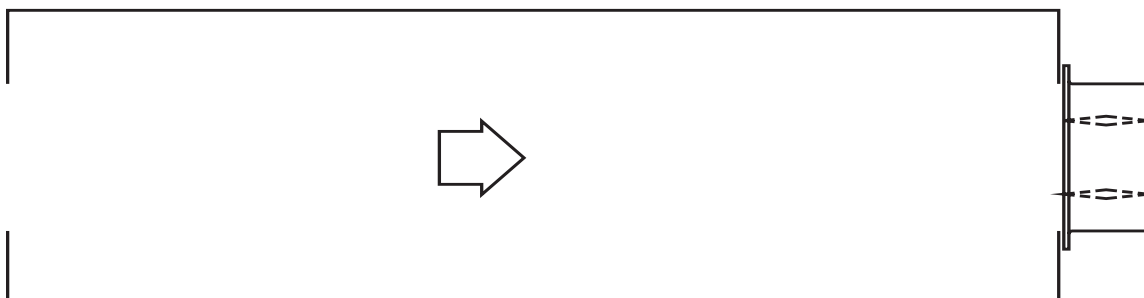

## AMCA Figure 5.2

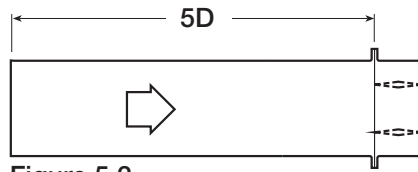

Figure 5.2

12 in. x 12 in. (305mm x 305mm)

Velocity (fpm)	Pressure Drop (in. wg)
500	0.04
1000	0.14
1500	0.31
2000	0.55
2500	0.86
3000	1.24
3500	1.69
4000	2.20

24 in. x 24 in. (610mm x 610mm)

Velocity (fpm)	Pressure Drop (in. wg)
500	0.02
1000	0.07
1500	0.16
2000	0.29
2500	0.45
3000	0.65
3500	0.89
4000	1.16

36 in. x 36 in. (914mm x 914mm)

Velocity (fpm)	Pressure Drop (in. wg)
500	0.01
1000	0.04
1500	0.09
2000	0.16
2500	0.25
3000	0.36
3500	0.49
4000	0.64

12 in. x 48 in. (305mm x 1219mm)

Velocity (fpm)	Pressure Drop (in. wg)
500	0.01
1000	0.06
1500	0.13
2000	0.23
2500	0.36
3000	0.52
3500	0.70
4000	0.92

48 in. x 12 in. (1219mm x 305mm)

Velocity (fpm)	Pressure Drop (in. wg)
500	0.03
1000	0.10
1500	0.23
2000	0.41
2500	0.63
3000	0.91
3500	1.24
4000	1.62

## AMCA Figure 5.3

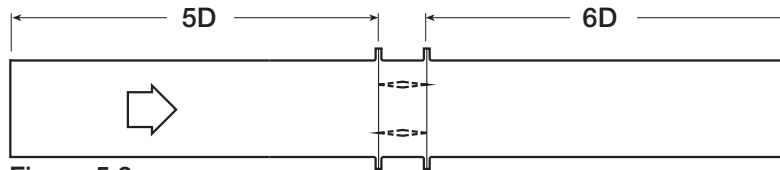

Figure 5.3

12 in. x 12 in. (305mm x 305mm)

Velocity (fpm)	Pressure Drop (in. wg)
500	0.02
1000	0.09
1500	0.20
2000	0.36
2500	0.56
3000	0.81
3500	1.10
4000	1.44

24 in. x 24 in. (610mm x 610mm)

Velocity (fpm)	Pressure Drop (in. wg)
500	0.01
1000	0.04
1500	0.09
2000	0.16
2500	0.25
3000	0.35
3500	0.48
4000	0.63

36 in. x 36 in. (914mm x 914mm)

Velocity (fpm)	Pressure Drop (in. wg)
500	0.01
1000	0.03
1500	0.06
2000	0.11
2500	0.17
3000	0.24
3500	0.33
4000	0.42

12 in. x 48 in. (305mm x 1219mm)

Velocity (fpm)	Pressure Drop (in. wg)
500	0.01
1000	0.04
1500	0.10
2000	0.17
2500	0.27
3000	0.39
3500	0.53
4000	0.70

48 in. x 12 in. (1219mm x 305mm)

Velocity (fpm)	Pressure Drop (in. wg)
500	0.02
1000	0.07
1500	0.16
2000	0.29
2500	0.45
3000	0.64
3500	0.88
4000	1.14

## AMCA Figure 5.5

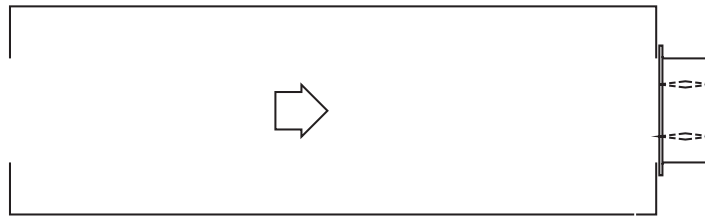

12 in. x 12 in. (305mm x 305mm)

Velocity (fpm)	Pressure Drop (in. wg)
500	0.06
1000	0.22
1500	0.50
2000	0.89
2500	1.39
3000	2.00
3500	2.72
4000	3.55

24 in. x 24 in. (610mm x 610mm)

Velocity (fpm)	Pressure Drop (in. wg)
500	0.03
1000	0.14
1500	0.31
2000	0.54
2500	0.85
3000	1.22
3500	1.66
4000	2.17

36 in. x 36 in. (914mm x 914mm)

Velocity (fpm)	Pressure Drop (in. wg)
500	0.03
1000	0.12
1500	0.26
2000	0.46
2500	0.73
3000	1.05
3500	1.42
4000	1.86

12 in. x 48 in. (305mm x 1219mm)

Velocity (fpm)	Pressure Drop (in. wg)
500	0.03
1000	0.13
1500	0.30
2000	0.53
2500	0.83
3000	1.19
3500	1.62
4000	2.11

48 in. x 12 in. (1219mm x 305mm)

Velocity (fpm)	Pressure Drop (in. wg)
500	0.04
1000	0.17
1500	0.38
2000	0.67
2500	1.04
3000	1.50
3500	2.05
4000	2.67



Greenheck India Pvt. Ltd. and Greenheck Kunshan Co. Ltd. certifies that the model FSD-211 shown herein is licensed to bear the AMCA Seal. The ratings shown are based on tests and procedures performed in accordance with AMCA Publication 511 and comply with the requirements of the AMCA Certified Ratings Programs. The AMCA Certified Ratings Seal applies to air performance ratings only.

## Actuators and Accessories

### Space Envelopes

Externally mounted actuators always require space outside of the damper sleeve. The "S" dimension illustrates the clearance required for various available actuators.

On dampers less than 18 in. (457mm) high, actuators may also require clearances above and/or below the sleeve. "B" and "T" dimensions are **worst** case clearance requirements for some dampers less than 18 in. (457mm) high. All damper sizes under 18 in. (457mm) high do not require these worst case clearances. If space availability above or below the damper sleeve is limited, each damper size should be individually evaluated.

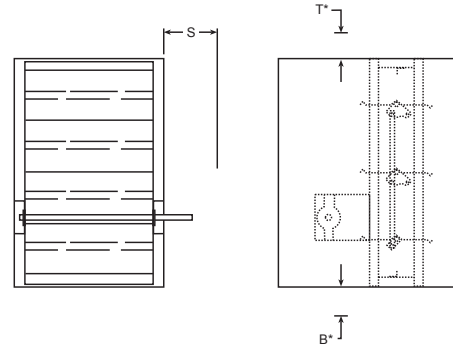

Actuator Type/Model	B*	T*	S	
	With RRL or RRL/OCI	With RRL or RRL/OCI	PiggyBack	
			No	Yes
<b>24 Volt AC</b>				
FSLF24 (-S) Belimo	3 1/2 in. (89mm)	0	6 in. (152mm)	NA
FSNF24 (-S) Belimo	12 3/4 in. (324mm)	0	6 in. (152mm)	9 in. (229mm)
MS8X09 Series Honeywell	4 3/4 in. (121mm)	0	6 in. (152mm)	NA
MS8120 Series Honeywell	12 3/4 in. (324mm)	0	6 in. (152mm)	9 in. (229mm)
<b>230 Volt AC</b>				
FSLF230 (-S) Belimo	3 1/2 in. (89mm)	0	6 in. (152mm)	NA
FSNF230 (-S) Belimo	12 3/4 in. (324mm)	0	6 in. (152mm)	9 in. (229mm)
MS4X09 Series Honeywell	4 3/4 in. (121mm)	0	6 in. (152mm)	NA
MS4620 Series Honeywell	12 3/4 in. (324mm)	0	6 in. (152mm)	9 in. (229mm)

\* For dampers 18 in. (457mm) or more in height these dimensions are 0 in. .

### Damper Sleeve Dimensional Data

The drawings below and corresponding table show the position of the FSD-211 damper when mounted in a factory sleeve. The standard mounting locations provide enough space for the mounting of actuators, controls and allow space for installation of retaining angles and duct connections.

The standard location of a damper mounted in a factory sleeve ("A" dimension) is shown below. The damper can be positioned at other locations within a range of 6 in. (152mm) to 12 in. (305mm) for the "A" dimension.

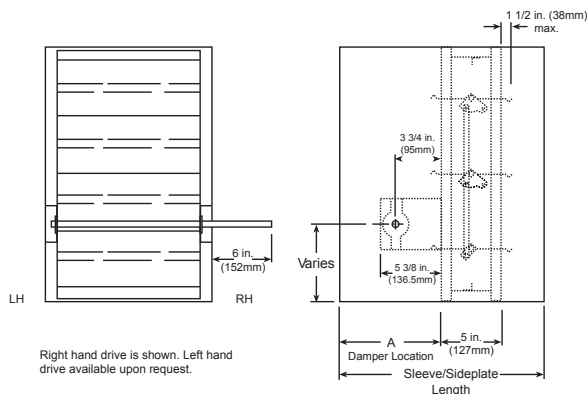

Right hand drive is shown. Left hand drive available upon request.

in. (mm)	"A" Dimension	
	Standard	Maximum
All Dampers*	7 3/16 (183)	12 (305)
When H is 11 in. (279mm) or less with OCI, or RRL	12 (305)	12 (305)

\*With the exception of dampers 10 in. high (254mm) or less.  
NOTE: Entire damper frame is not required to be installed within the wall. The damper blades, when closed should be contained within the wall.

# Damper Sizing Information

# FSD-211

Dampers larger than maximum single section size are supplied as a factory assembly of two or more sections of equal size. The following figures show maximum damper section size and assembly configurations for multi-section dampers.

Single Section

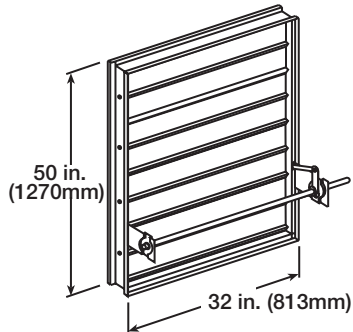

Double Section

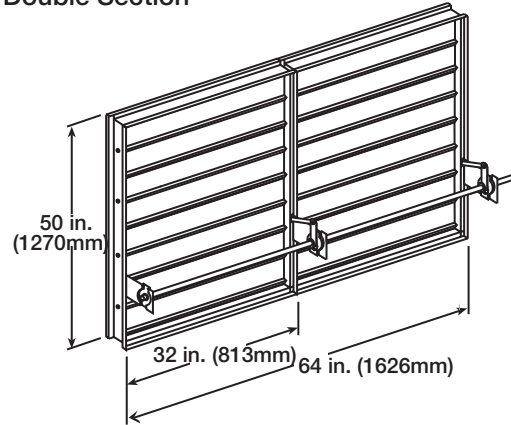

## Transitioned Damper Dimensions

When a fire/smoke damper is being used in conjunction with round or oval ductwork, the FSD-211 can be supplied in a factory sleeve with round or oval transitions on both ends of the sleeve. Dampers should be ordered to the duct dimensions. Drawings below show overall damper size.

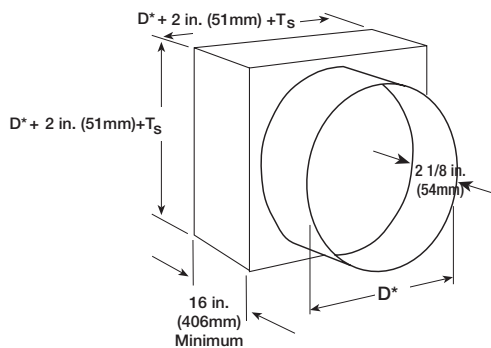

TYPE R

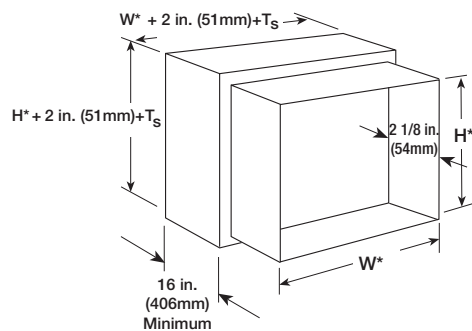

TYPE C

\* These dimensions are furnished approximately 1/4 in. (6mm) undersize, except round and oval dimensions which are approximately 1/8 in. (3mm) undersize.

$T_s = (2)(\text{Sleeve Thickness})$

# Specifications

---

Combination Fire Smoke Dampers meeting the following specifications shall be furnished and installed where shown on plans and/or as described in schedules. Dampers shall meet the requirements of NFPA 80, 90A, 92A, 92B, 101 & 105 and further shall be tested, rated and labeled in accordance with the latest edition of UL Standards 555 and 555S. Dampers shall have a UL555 fire rating of 1½ hours and be of low leakage design qualified to UL 555S Leakage Class I.

Each damper/actuator combination shall have a UL555S elevated temperature rating of 250°F (121°C) minimum and shall be operational and dynamic rated to operate at maximum design air flow at its installed location. Each damper shall be supplied with an appropriate actuator installed by the damper manufacturer at the time of damper fabrication. Damper actuator shall be (specifier select one of the following) electric type for 24 or 230 volt operation.

Damper blades shall be 16 ga. (1.5mm) galvanized steel 3V type with three longitudinal grooves for reinforcement. Damper frame shall be galvanized steel formed into a structural hat channel shape with reinforced corners. Bearings shall be 304SS type rotating in extruded

holes in the damper frame. Blade edge seals shall be silicone rubber designed to inflate and provide a tighter seal against leakage as pressure on either side of the damper increases. Jamb seals shall be stainless steel compression type. Blades shall be completely symmetrical relative to their axle pivot point, presenting identical resistance to airflow in either direction or pressure on either side of the damper.

The Damper Manufacturer's submittal data shall certify all air performance pressure drop data is licensed in accordance with the AMCA Certified Ratings Program for Test Figures 5.2, 5.3, and 5.5. Damper air performance data shall be developed in accordance with the latest edition of AMCA Standard 500-D. Dampers shall be labeled with the AMCA Air Performance Seal.

Damper must be rated for mounting vertically (with blades running horizontal) or horizontally and be UL 555S rated for leakage and airflow in either direction through the damper. Each damper shall be supplied with a 165°F (74°C) RRL. The basis of design is Greenheck Model FSD-211.



Greenheck Kunshan: No. 1188 Pengqing Road, Huaqiao Town, Kunshan Jiangsu 215332 P.R.C.  
Greenheck India: 541/542, 5th Floor, Tower B, Spaze i Tech Park, Sector-49, Sohna Road, Guragon

Copyright ©2017 Greenheck Fan Corporation  
FSD-211 Rev 10 March 2017