

MODEL S2H

Class II • 250°F or 350°F • Galvanized Steel • Single Thickness Blade • Smoke Damper

STANDARD MATERIALS AND CONSTRUCTION

- FRAME:** 5½" x ¾" x 16-GA galvanized steel hat channel; Flat 16-GA galvanized head and sill for maximum free area on dampers ≤ 13" high
- BLADES:** 16-GA galvanized steel single thickness; Parallel action
- AXLES:** Plated solid steel stub
- BEARINGS:** Oil impregnated bronze
- LINKAGE:** Plated steel angle and crank plates with stainless steel pivots, in-jamb type or on-blade type
- STOPS:** 18-GA galvanized steel angles at head and sill
- BLADE SEALS:** Silicone
- JAMB SEALS:** Stainless steel
- SLEEVE:** Minimum 20-GA galvanized steel by 18" long (sizes greater than 84" wide or 84" high require minimum 18-GA)
- CAULKING:** Hardcast Irongrip 601 or UL-listed equivalent
- ACTUATOR:** Electric or pneumatic; Factory-installed for Power-Open/ Spring-Close (fail close) operation; External left hand mounted as viewed from jackshaft side of damper
- FINISH:** Mill

UNDERWRITERS LABORATORIES INC.®
 CLASSIFIED DYNAMIC SMOKE DAMPER
 LEAKAGE RESISTANCE CLASS II

abi air balance

FILE #R4708



This smoke damper meets the construction and performance requirements of:

- Underwriters Laboratories Inc. Standard 555S
- National Fire Protection Association Standards 80 and 90A
- ICC's International Building Code
- California State Fire Marshal Listing #3230-1328:106
- Underwriters Laboratories Inc. Approved for dual direction airflow and dynamic conditions.
- Underwriters Laboratories Inc. Classified for use in smoke control systems for Leakage Class II and 250°F or 350°F.
- Actuators must be controlled by a smoke detection system.

OPTIONS

- Exact Size (no undercut)
- Sleeve - Transition
- Actuators - 120V, 24V, 230V or Pneumatic
- Right Hand and/or Internal Actuator Mounting Locations (Restrictions Apply)
- Dual Position Indication (IDPI) Switches
- Model SM-501 Flow-Rated Smoke Detector.
- Model 2151 No-Flow Smoke Detector (12" Minimum Damper Height)
- Remote Test Box
- Copper Tubing (for Pneumatic Actuators)
- Transformers
- Tab-Lock Retaining Angles - 1 or 2 Sets
- Bearings - Stainless Steel
- Axle - Stainless Steel
- Security Bars
- Short-Width (<8") and/or Short-Height (<8") Transitions

NOTES

1. approximately ¼" undersize.
2. Damper ≥ 12" in height with factory mounted SM-501 smoke detectors require a minimum 19" deep sleeve (10.5" on the actuator side); detectors will be mounted on the side of the damper opposite actuator.
3. Damper < 12" in height with factory mounted SM-501 smoke detectors require a minimum 20" deep sleeve (11.5" on the actuator side); detectors will be mounted on the bottom or top of damper.
4. Smoke Detectors can be ordered for field mounting with standard 18" deep sleeve.

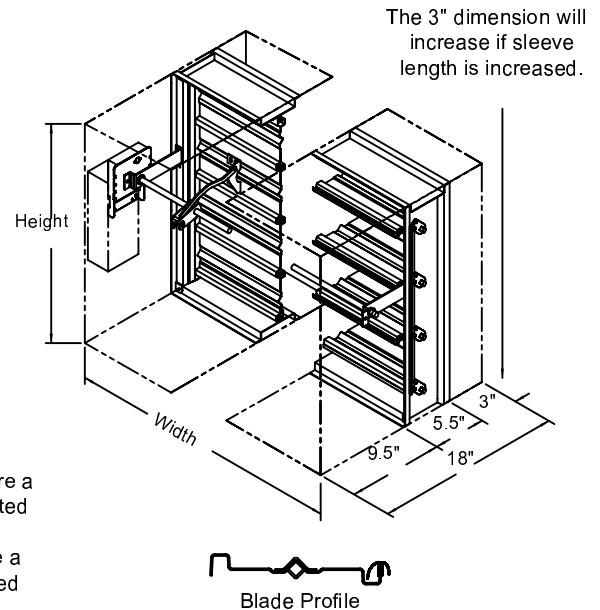

DAMPER SIZES

		2000 fpm, 4 in.wg				3000 fpm, 4 in.wg	
Orientation	H or VertH	orizantal & Vertical				Horizontal & Vertical	
Panels	M inimum Panel	Max Panel 250°	Max Panel 350°	Max Assy 250°	Max Assy 350°	Max Panel 250°	Max Assy 250°
Rectangular	4"W x 4"H (8"W x 8"H frame)	36"W x 48"H 48"W x 36"H	36"W x 48"H	144"W x 70"H 288"W x 35"H	128"W x 62"H 256"W x 31"H	36"W x 36"H	108"W x 36"H
Round	4" dia. (8"W x 8"H frame)	34" dia.	34" dia.	68" dia.	60" dia.	34" dia.n	/a
Oval	4"W x 4"H (8"W x 8"H frame)	34"W x 46"H 46"W x 34"H	34"W x 46"H	45 sq.ft. 106"W x 68"H	106"W x 60"H	34"W x 34"H	106"W x 24"H

*Dampers smaller than minimum frame size require a transition. Reference SD-TRFS.



MODEL S2H

Class II • 250°F or 350°F • Galvanized Steel • Single Thickness Blade • Smoke Damper

Operations Rating:

Maximum Differential Pressure: 4 in.wg
 Maximum Face Velocity: 2000 fpm (3000 fpm for selected size/actuator combinations)

Leakage Rating:

UL Class II
 10 cfm per sq.ft. maximum @ 1 in.wg
 20 cfm per sq.ft. maximum @ 4 in.wg

Sound Ratings:

The Noise Criterion data below was tested in accordance with ASTM E477.99 in the center octave band.

Noise Criterion (NC)				
Damper Size	Velocity (fpm)			
	1000	2000	3000	4000
12"W x 12"H	31	53	64	71
24"W x 24"H	33	54	65	n/a

Pressure Drop Ratings:

The pressure drop data shown below is based on laboratory conditions. The test setup does not take into account elbows or other duct fittings that are part of every actual duct system. The configuration of the actual duct system immediately upstream and downstream of the damper often contributes more pressure loss than the damper itself.

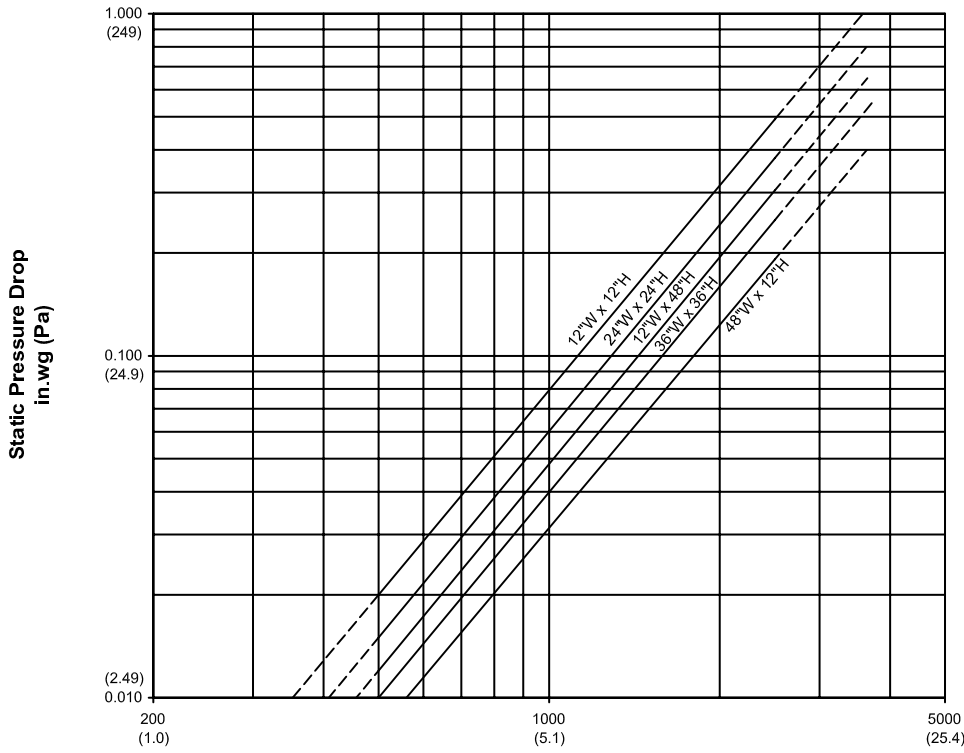

Face Velocity
 fpm (m/s)
AMCA Figure 5.3



Air Balance certifies that the model S2H damper shown here is licensed to bear the AMCA seal. The ratings shown are based on tests and procedures performed in accordance with AMCA Publication 511 and comply with the requirements of the AMCA Certified Ratings Program. The AMCA Certified Ratings Seal applies to Air Performance Ratings only.



Dampers  Louvers
 UL Life Safety Products
 Division of Mestek
 Member of AMCA