

### In Duct or Flanged to Duct Install Types

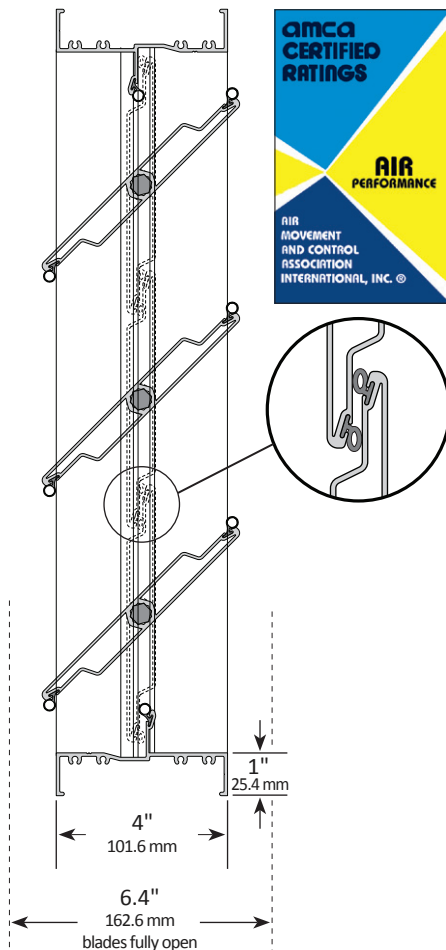

<b>Leakage Rating:</b>	Class 1
<b>Operational Rating:</b>	Airflow: 2000 fpm (10.2 m/s). Rated for airflow in either direction.
	Temperature: 250°F (121°C)
	Pressure: 4" w.g. (1 kPa) static pressure differential
<b>Fail Position:</b>	Closed

#### STANDARD CONSTRUCTION:

1. Extruded aluminum (6063-T5) smoke damper frame is not less than 0.080" (2.03 mm) in thickness. Damper frame is 4" (101.6 mm) deep x 1" (25.4 mm), with mounting flanges on both sides of frame. Damper frame has a 2" (50.8 mm) mounting flange on the rear of the damper, when ordered as Extended Rear Flange install type.
2. Blades are maximum 6" (152.4 mm) deep extruded aluminum (6063-T5) air-foil profiles. All blades are symmetrically pivoted.
3. Blade and frame seals are specially designed and engineered extruded silicone. Seals are secured in an integral slot within the aluminum extrusions. Blade and frame seals are mechanically fastened to prevent shrinkage and movement over the life of the damper.
4. Bearings are composed of a bronze oilite inner bearing - fixed around a 7/16" (11.11 mm) aluminum hexagon blade pivot pin - rotating within a bronze oilite outer bearing inserted in the frame.
5. The 7/16" (11.11 mm) hexagonal drive rod, U-bolt fastener, and hexagonal retaining nuts are zinc-plated steel. These provide a positive connection to blades and linkage.
6. Aluminum and corrosion-resistant zinc-plated steel linkage hardware is installed in the frame side, complete with cup-point trunnion screws for a slip-proof grip.
7. Smoke dampers are designed for operation in temperatures ranging from -40°F (-40°C) to 250°F (121°C).
8. Smoke dampers are custom made to required size, without blanking off free area.
9. Smoke dampers are available with parallel blade action.

#### CONSTRUCTION OPTIONS:

For each option listed, replace the lines above with their corresponding lines below.

##### MR - MOISTURE RESISTANCE OPTION:

1. Extruded aluminum (6063-T5) smoke damper frame is not less than 0.080" (2.03 mm) in thickness. Damper frame is 4" (101.6 mm) deep x 1" (25.4 mm), with mounting flanges on both sides of frame. Damper frame has a 2" (50.8 mm) mounting flange on the rear of the damper, when ordered as Extended Rear Flange install type. Frame is assembled using stainless steel screws.
5. The 7/16" (11.11 mm) hexagonal drive rod, U-bolt fastener, and hexagonal retaining nuts are stainless steel. These provide a positive connection to blades and linkage.
6. Aluminum and stainless steel linkage hardware is installed in the frame side, complete with cup-point trunnion screws for a slip-proof grip.

##### SW - SALT WATER RESISTANCE OPTION:

1. Extruded aluminum (6063-T5) smoke damper frame is not less than 0.080" (2.03 mm) in thickness. Damper frame is 4" (101.6 mm) deep x 1" (25.4 mm), with mounting flanges on both sides of frame. Damper frame has a 2" (50.8 mm) mounting flange on the rear of the damper, when ordered as Extended Rear Flange install type. Aluminum frame is clear anodized to a minimum thickness of 0.7 mil (18 microns) deep. Frame is assembled using stainless steel screws.
2. Blades are maximum 6" (152.4 mm) deep extruded aluminum (6063-T5) air-foil profiles, clear anodized to a minimum thickness of 0.7 mil (18 microns) deep. All blades are symmetrically pivoted.
5. The 7/16" (11.11 mm) hexagonal drive rod, U-bolt fastener, and hexagonal retaining nuts are stainless steel. These provide a positive connection to blades and linkage.
6. Linkage hardware is installed in the frame side. All aluminum linkage hardware parts are clear anodized. All non-aluminum linkage hardware parts are stainless steel. They are complete with cup-point trunnion screws for slip-proof grip.

### Extended Rear Flange Install Type

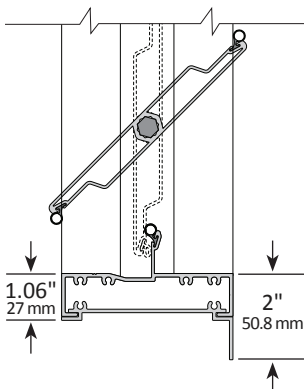

#### TAMCO® Series 1000 SM meets the requirements for smoke dampers established by:

UL 555S/ULC-S112.1 File R16679  
National Fire Protection Association:  
NFPA Standards 80, 90A, 92, 101, 105  
California State Fire Marshall Listing#: 3230-2116:0100





**TAMCO® Series 1000 SM meets the requirements for smoke dampers established by:**

UL 555S/ULC-S112.1 File R16679

National Fire Protection Association:

NFPA Standards 80, 90A, 92, 101, 105

California State Fire Marshall Listing#:

3230-2116:0100

**MINIMUM OPENING SIZE:**

11" w x 6" h (280 mm x 153 mm)

**MAXIMUM SINGLE-SECTION OPENING SIZE:**

36" w x 48" h (915 mm x 1220 mm)

**MAXIMUM MULTI-SECTION OPENING SIZES:**

144" w x 96" h (3658 mm x 2438 mm)

288" w x 48" h (7316 mm x 1220 mm)

**INSTALLATION:**

10. Smoke dampers may be mounted vertically (*standing up/horizontal airflow*) with blades running horizontally, or mounted horizontally (*lying down/vertical airflow*).
11. Dampers are available in four install types: Installed In Duct, Flanged to Duct, Extended Rear Flange, and Square to Round Transition. (*See Install Types pages for details.*)
12. Multi-section smoke dampers may require field assembly of sections.
13. Installation of dampers must be in accordance with TAMCO's current UL/ULC Approved Smoke Damper Installation Guidelines, provided with each smoke damper shipment. (*Printed installation guidelines are provided with each damper shipment, however all technical information available on TAMCO's web site at [www.tamcodampers.com](http://www.tamcodampers.com) supersedes information contained within printed versions.*)

**ACTUATORS:**

14. UL 555S/ULC-S112.1 requires that all actuators for smoke dampers be factory mounted. Approved actuators are Belimo and Honeywell.
15. Voltage: 24 vac, 120 vac, 230 vac, single phase.
16. Mounting: Internal or external actuator mounting. (*All smoke dampers with internally mounted actuators, will be mounted on a jackshaft. If actuator side of damper is to be connected to duct work, smoke damper assembly will have to be installed in a sleeve.*)
17. Options: Auxiliary switches.
18. Actuator quantity and location requirements are shown in, and must be in accordance with, TAMCO UL/ULC Approved Smoke Damper Configurations.

**PERFORMANCE DATA | Series 1000 SM**

UL/ULC Approved Smoke Damper

**VELOCITY VS. PRESSURE DROP**

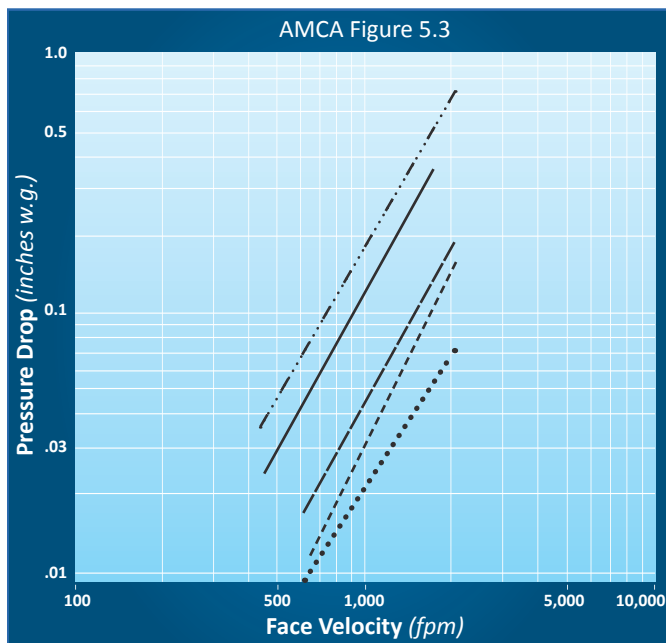

**LEGEND:**

12" x 12" — (305 mm x 305 mm)

24" x 24" - - - (610 mm x 610 mm)

48" x 12" - · - · (1220 mm x 305 mm)

12" x 48" — (305 mm x 1220 mm)

36" x 36" · · · · (915 mm x 915 mm)

T.A. Morrison & Co. Inc. certifies that the TAMCO Series 1000 SM UL/ULC Approved Smoke Damper shown herein is licensed to bear the AMCA Seal. The ratings shown are based on tests and procedures performed in accordance with AMCA Publication 511 and comply with the requirements of the AMCA Certified Ratings Program. The AMCA Certified Ratings Seal applies to air performance ratings.



**FIG. 5.3** Test damper is fully ducted with a 5 diameter duct run upstream, and a 6 diameter duct run downstream.

Pressure drop values are based on Flanged to Duct install type. Pressure drop will be greater for In Duct install type dampers.

## UL/ULC Approved Smoke Damper

- > Always provide opening width and height dimensions, when ordering.
- > Width dimension is always parallel to blades.
- > Height dimension is always perpendicular to blades.

## INSTALLED IN DUCT TYPE ▾

- > Finished damper O.D. is  $\frac{1}{4}$ " (6.4 mm) less than opening width and height dimensions.

**MINIMUM SECTION SIZE:**

11" w x 6" h (280 mm x 153 mm)

**MAXIMUM SECTION SIZE:**12 ft<sup>2</sup> (1.1 m<sup>2</sup>)

36" w x 48" h (915 mm x 1220 mm)

**INTERNAL ACTUATOR**

Must be inserted in a sleeve, or opening.

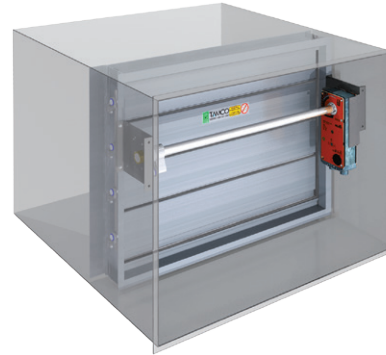

## FLANGED TO DUCT TYPE ▾

- > Finished damper O.D. is 2" (50.8 mm) greater than opening width and height dimensions.

**MINIMUM SECTION SIZE:**

11" w x 6" h (280 mm x 153 mm)

**MAXIMUM SECTION SIZE:**12 ft<sup>2</sup> (1.1 m<sup>2</sup>)

36" w x 48" h (915 mm x 1220 mm)

**EXTERNAL ACTUATOR**

Both front and rear flanges can be mounted to opening surfaces.

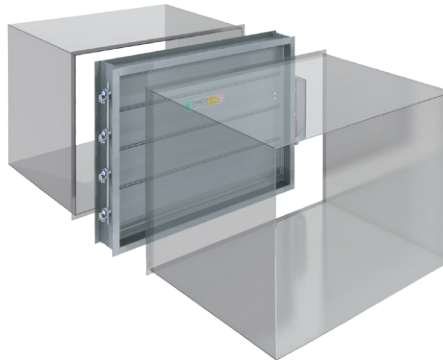
**INTERNAL ACTUATOR**

Only rear flange can be mounted to opening surface.

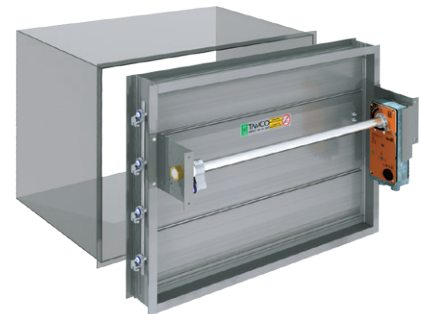

## EXTENDED REAR FLANGE TYPE ▾

- > Finished damper O.D. is 4" (101.6 mm) greater than opening width and height dimensions.

**MINIMUM SECTION SIZE:**

11" w x 6" h (280 mm x 153 mm)

**MAXIMUM SECTION SIZE:**12 ft<sup>2</sup> (1.1 m<sup>2</sup>)

36" w x 48" h (915 mm x 1220 mm)

- > Extended Rear Flange install type dampers are not designed so that the front of the damper may be inserted into an opening, as the side frame members extend to the full height of the rear flange.

**EXTERNAL ACTUATOR**

Both front and rear flanges can be mounted to opening surfaces.

**INTERNAL ACTUATOR**

Only rear flange can be mounted to opening surface.



### SQUARE TO ROUND TRANSITION ▾

- > Always provide duct diameter dimension when ordering.
- > If using TAMCO Connect software to submit orders, enter diameter dimension in both the width and height fields.
- > Transition pieces are a minimum of 18 ga. galvanized steel for Series 1000 SM smoke dampers when ordered with no option.
- > Transition pieces are 304 stainless steel, when Series 1000 SM smoke dampers are ordered with the MR or SW Options.
- > Transition pieces and damper are sealed together.
- > Dampers are built 4" (102 mm) larger than specified duct diameter. (Dampers are fabricated square.)
- > Finished transition diameter is  $\frac{1}{4}$ " (6.35 mm) less than specified duct diameter, providing clearance for mating duct which slides over round transition. This ensures free movement of damper blades.

<b>MINIMUM DUCT DIAMETER:</b>	
9"	(229 mm)
<b>MAXIMUM DUCT DIAMETER:</b>	
58"	(1474 mm)
<b>MAXIMUM SECTION SIZE:</b>	
12 ft <sup>2</sup>	(1.1 m <sup>2</sup> )
<b>MAXIMUM FINISHED OD:</b>	
62"w x 62"h	(1575 mm x 1575 mm)

### EXTERNAL ACTUATOR ONLY

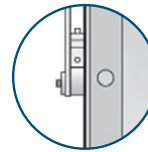
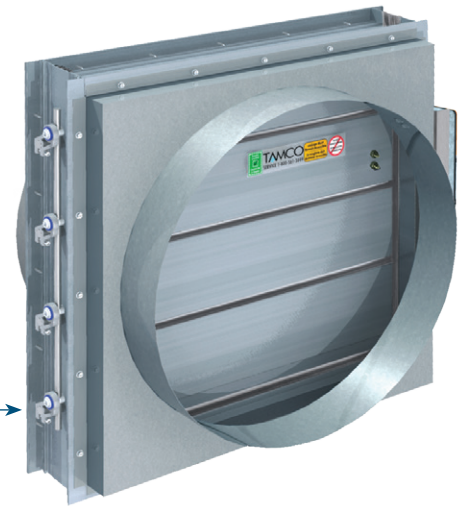

Linkage extends up to  $1\frac{5}{16}$ " (33 mm) beyond the outer edge of the transition.

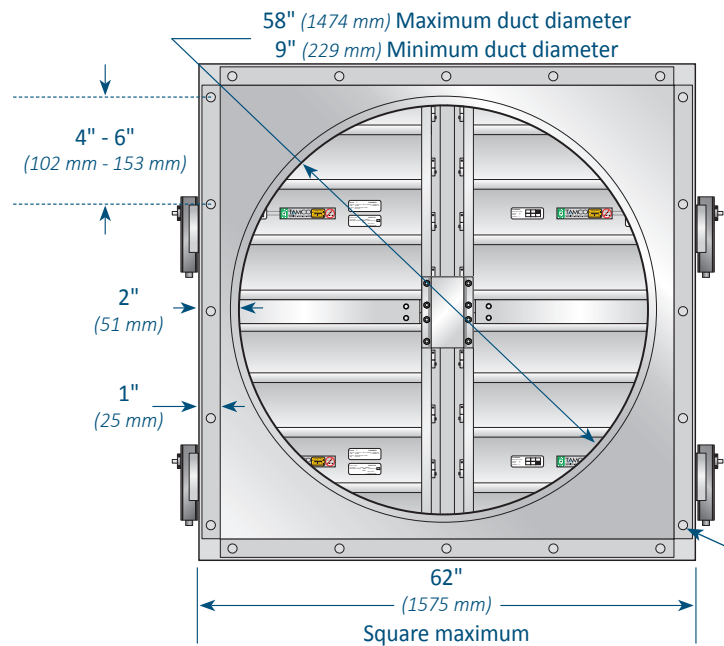
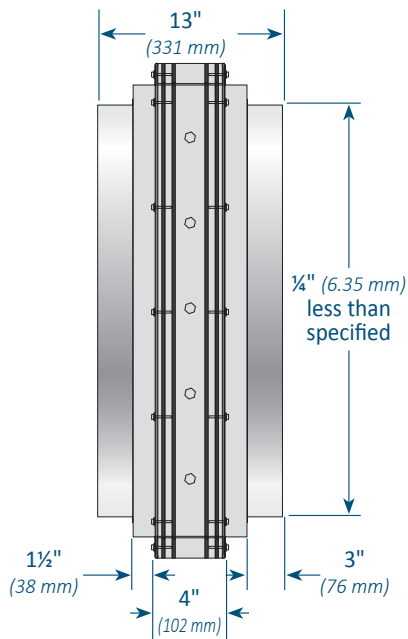

Transition attaches to damper frame or sleeve with minimum #8 sms screws,  $\frac{1}{4}$ " bolts,  $\frac{3}{16}$ " rivets, or welds.