

## FSD60 COMBINATION FIRE AND SMOKE DAMPER 1½ HOUR UL555 RATED, UL555S LEAKAGE CLASS 1

### APPLICATION

The FSD60 is a combination fire and smoke damper designed with airfoil blades for the lowest pressure drop that provides point-of-origin fire containment and operational flexibility in static and dynamic smoke management systems. The FSD60 may be installed vertically in walls or horizontally in concrete floors and has been qualified to 2,000 fpm and 4" w.g. on all sizes and 3,000 fpm and 4" w.g. on select sizes (consult Ruskin for size information).

### STANDARD CONSTRUCTION

#### FRAME

5" x 16 gage (127 x 1.6) galvanized, hat-shaped channel, structurally superior to 13 (2.3) gage channel frame.

#### BLADES

Airfoil-shaped, double-skin, single piece construction with 14 gage equivalent thickness, maximum 6" (152) wide.

#### BEARINGS

Stainless steel sleeve, pressed into frame.

#### JAMB SEALS

Stainless steel, flexible metal compression type.

#### BLADE SEALS

Silicone edge type for smoke seal to 450°F (232°C) and galvanized steel for flame seal to 1900°F (1038°C).

#### LINKAGE

Concealed in frame.

#### CONTROLLED CLOSURE DEVICE (HEAT-ACTUATED)

165°F (74°C) standard. 212°F (100°C), 250°F (121°C), 285°F (141°C) PFL only, or 350°F (177°C) are available at no additional cost.

### DAMPER SIZES

#### MINIMUM SIZE

8"w x 6"h (203 x 152).

#### MAXIMUM SIZE

Single Section

32"w x 48"h (813 x 1219)

Multiple Section

Vertical Installation – 120"w x 96"h (3048 x 2438)

Horizontal Installation – 144"w x 96"h (3658 x 2438)

### OPTIONS

- **TS150 FireStat** for reopenable operation in dynamic smoke management systems.
- **DSDf/DSDN Duct Smoke Detector** (Flow rated or No-Flow).
- **SP100 Switch Package** to remotely indicate damper blade position.
- **FAST Angle** factory supplied for labor saving angle one-side installations.
- **Factory Sleeves** of various lengths and gages to insure field compliance with UL installation requirements.
- **MCP** control panels for test purposes or smoke management systems.

### NOTES

1. Damper are furnished approximately 1/4" (6) smaller than given opening dimensions.
2. Dimensions shown in parentheses ( ) indicate millimeters.

Model FSD60 meets the requirements for fire, smoke and combination fire and smoke dampers established by:

- **National Fire Protection Association NFPA Standards** 90A, 92A, 92B and 101
- **BOCA National Building Codes**
- **ICBO Uniform Building Codes**
- **SBCCI Standard Building Codes**
- **ICC International Building Codes**
- **CSFM California State Fire Marshal Fire Damper Listing** (#3225-245:102) and Smoke Damper Listing (#3230-245:110)
- **New York City** (BSA Listing #176-82-SM)

### UL CLASSIFIED

UL555 Listing R5531, UL555S Listing R5531

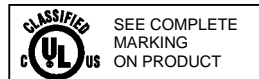

### FEATURES

The FSD60 offers:

- EFL (Electric Fuse Link) or PFL (Pneumatic Fuse Link) heat-actuated release devices permit controlled (rather than instantaneous) closure through the damper actuator. The EFL and PFL allow the damper to automatically reopen after a test, smoke detection or power failure condition.
- EFL is standard on dampers with electric actuators.
- PFL is standard on dampers with pneumatic actuators.
- EFL's may be ordered on dampers with pneumatic actuators but require an additional EP switch.

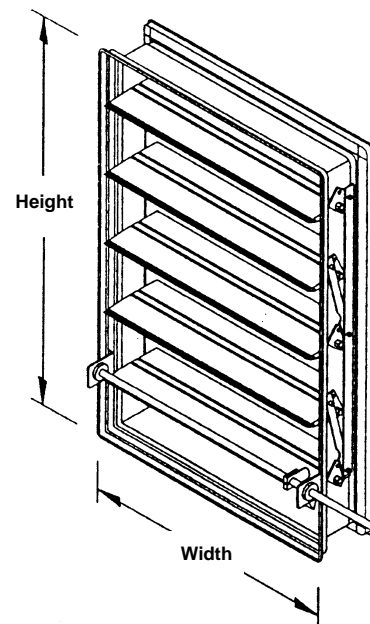

# AMCA LICENSED AIR PERFORMANCE DATA



Ruskin Company certifies that the FSD60 shown hereon is licensed to bear the AMCA Seal. The ratings shown are based on tests and procedures performed in accordance with AMCA Publication 511 and comply with the requirements of the AMCA Certified Ratings Program. The AMCA Certified Ratings Seal applies to air performance for the FSD60.

To determine the AMCA Licensed air performance:

Locate the applicable feet per minute face velocity on the bottom of the velocity vs. pressure drop chart below. Move up the chart to the most appropriate size damper line. From the intersection point, move left to determine the pressure drop on the left side of the chart.

For other damper sizes refer to **Air Performance Data For All Fire and Smoke Dampers** spec sheet.

**VELOCITY vs. PRESSURE DROP**

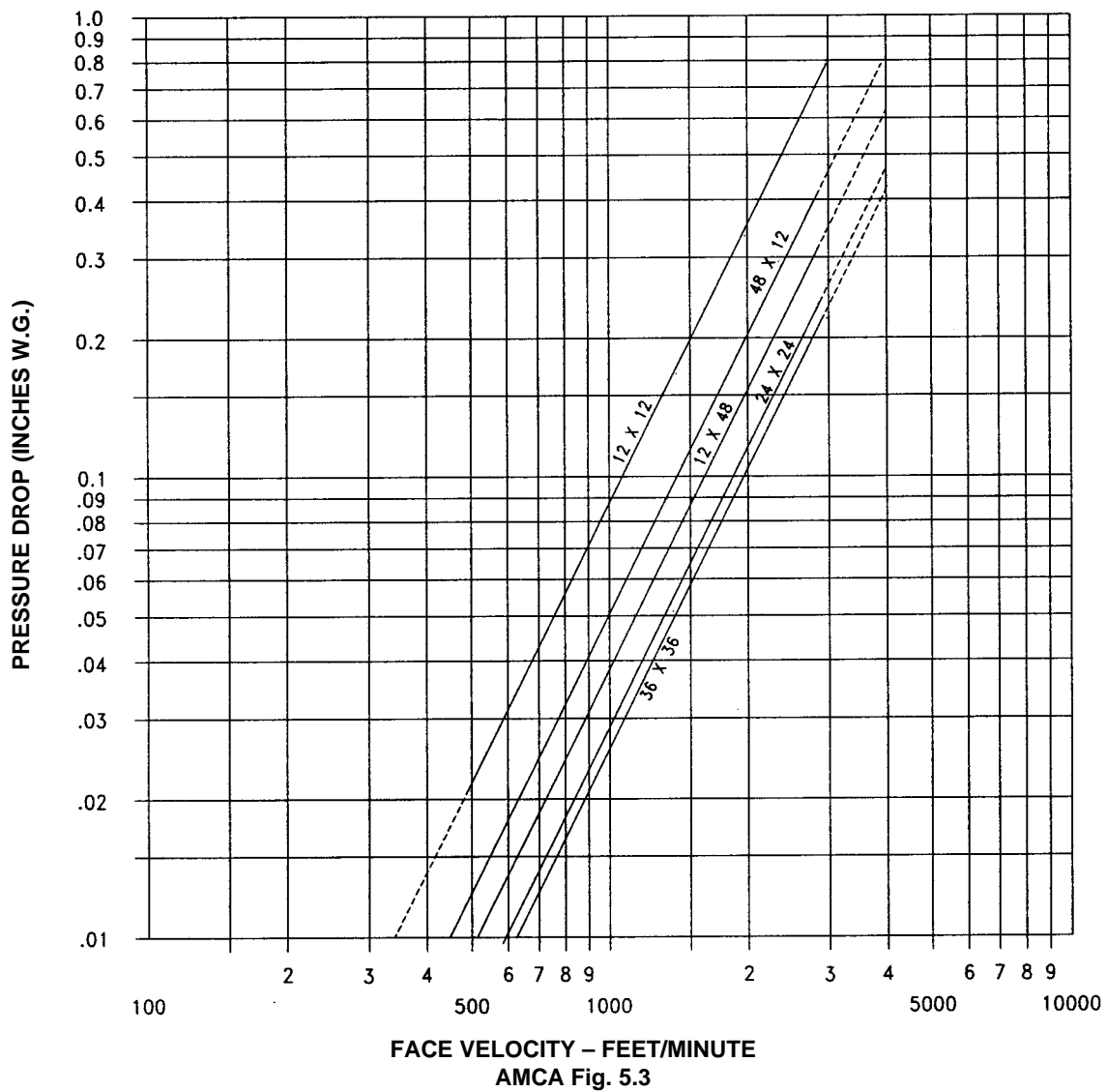

## SPACE ENVELOPE

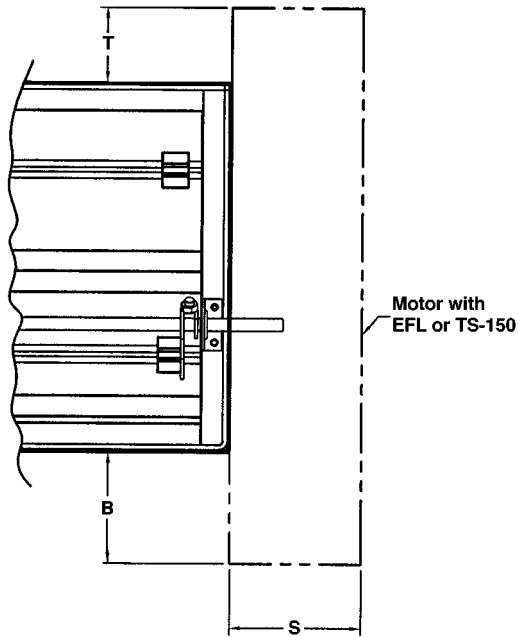

Externally mounted actuators require space outside the damper sleeve. The "S" dimension is the "side" clearance, the "T" dimension is the "top" clearance and the "B" dimension is the "bottom" clearance required for the various actuators approved for use with Ruskin fire/smoke dampers. Actuators and accessories are factory mounted on the right side when viewed from the actuator side of the wall or floor. Ruskin fire/smoke dampers can be rotated or turned over to accommodate the application. If the actuator must be mounted on top or bottom, select the FSD60V.

The most commonly used electric actuators are shown in the table below. Refer to the **Actuators And Accessories Space Envelopes For All Fire and Smoke Dampers** data sheet for actuators and space information not shown.

ACTUATORS	H (Damper Height)	S	T	B
H2000, H2024	15" (381)	4" (102)	0" (0)	N/A
MS4209, MS8209	15" (381)	4" (102)	0" (0)	N/A
MS4120, MS8120	17" (432)	5" (127)	0" (0)	N/A
FSNF120, GGD221	17" (432)	5" (127)	0" (0)	N/A

### NOTES:

- The "H" dimension represents the required height to encompass the actuator and accessories with nothing protruding above or below the damper.
- The "B" (bottom) dimension does **Not Apply** to the "H" sizes shown. The MS4120, MS8120, FSNF120 and GGD221 will hang below the damper on sizes 10" (254) high and shorter.

## DAMPER SLEEVE DIMENSIONAL DATA

The drawing and corresponding table show the position of the damper when mounted in a factory sleeve. The standard mounting locations provide enough space for the mounting of actuators, controls and allow space for installation of retaining angles and duct connections. The minimum factory sleeve length is 17" (432). Consult Ruskin for shorter sleeve lengths.

The standard location of a damper mounted in a factory sleeve ("L" dimension) is shown at right.

### NOTE:

The entire damper frame is not required to be installed within the wall. The damper blades, when closed should be contained within the wall.

#### \*Minimum Sleeve Length Formula:

$$\text{Sleeve Length} = \text{"L" dimension} + \text{wall/floor thickness} + 3" \text{ sleeve non-motor side}$$

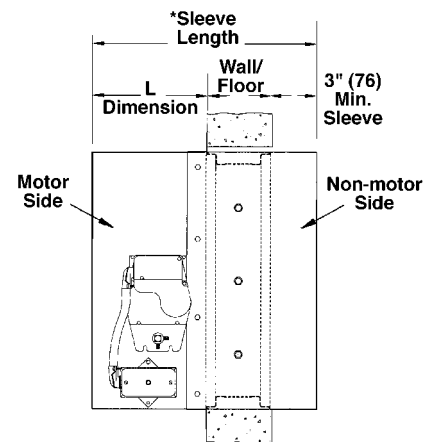

**Note:** See basic UL Installation Instructions for complete installation requirements.

	All dampers with EFL or PFL		All dampers with TS150 or SP100							
			Electric Actuators		Pneumatic Actuators					
	Over 10" (254) High	10" (254) High and Under	Over 21" (533) High (see note)	21" (533) High and Under (see note)	331-4827(P)		331-2961(P)		331-3060(P)	
					Over 28" (711) High	28" (711) High & Under	Over 32" (813) High	32" (813) High & Under	Over 40" (1016) High	40" (1016) High & Under
"L"	7 1/8" (181)	10 5/8" (270)	7 1/8" (181)	10 5/8" (270)	7 1/8" (181)	10 5/8" (270)	7 1/8" (181)	10 5/8" (270)	7 1/8" (181)	10 5/8" (270)

**Note:** The 21" (533) dimension becomes 32" (813) when the MS4120, MS8120, GGD221 or FSNF120 are utilized.

## DIMENSIONAL INFORMATION

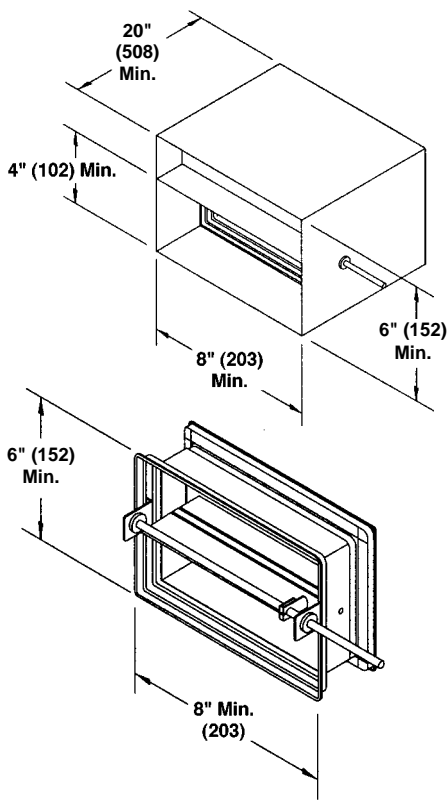

### MINIMUM SIZES

Nominal – 8" w x 6" h (203 x 152).

Actual – 7<sup>3</sup>/<sub>4</sub>" w x 5<sup>3</sup>/<sub>4</sub>" h (197 x 146).

Dampers with heights (B dimension) less than 6" (152) require Style B transitions and a sleeve. The damper itself remains 6" (152) high.

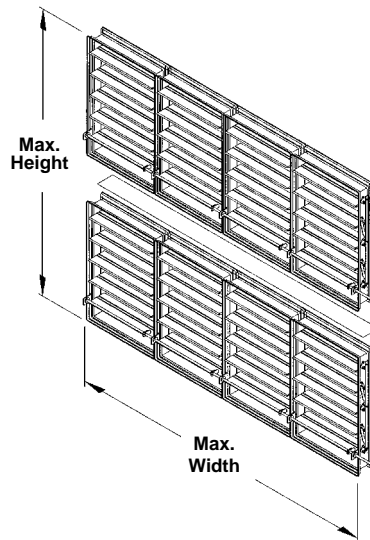

### MAXIMUM UL CLASSIFIED SIZE

Single Section:

32" w x 48" h (813 x 1219)

Multiple Section Assembly

Vertical Installation –  
120" w x 96" h (3048 x 2438)

Horizontal Installation  
144" w x 96" h (3658 x 2438)

For dampers exceeding these dimensions consult Ruskin.

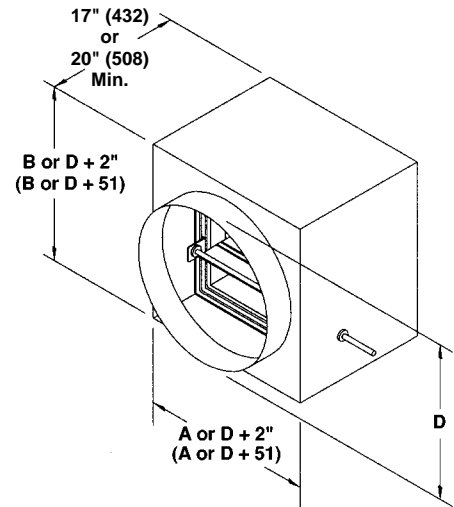

### ROUND, OVAL OR RECTANGULAR DUCT TRANSITION CONNECTION

FSD60 dampers supplied with round connections (R for low pressure, CR for medium pressure or WR welded for high pressure) are:

Minimum 4" (102) in diameter

Maximum 94" (2388) in diameter

The square size of the damper will be 2" (51) larger than the diameter dimension ordered.

FSD60 dampers supplied with rectangular connections (C for low to medium pressure or WC welded for high pressure) are:

Minimum 6" w x 4" h (152 x 102)

Maximum 118" x 94" h (2997 x 2388)

The square size of the damper will be 2" (51) larger than the width and height of the damper A x B dimensions.

FSD60 dampers supplied with oval connections (LO, CO, WO) will be 2" (51) larger than the width and height of the damper A x B dimensions.

## SPECIFICATION

Combination fire smoke dampers meeting or exceeding the following specifications shall be furnished and installed at locations shown on plans or as described in schedules. Dampers shall meet the requirements of NFPA90A, 92A and 92B. Dampers shall have a fire rating of 1 1/2 hours in accordance with the latest edition of UL555 and shall be classified as Leakage Class I Smoke Dampers in accordance with the latest version of UL555S. Dampers shall be warranted to be free from defects in material and workmanship for a period of 5 years after date of shipment.

Each fire smoke damper shall be AMCA licensed and shall bear the AMCA Certified Ratings Seal for Air Performance. AMCA certified testing shall verify pressure drop does not exceed .03" w.g. at a face velocity of 1,000 fpm on a 24" x 24" damper.

In addition the dampers and their actuators shall have a UL555S elevated temperature rating of 250°F (121°C) or 350°F (177°C) depending upon the actuator. Appropriate electric or pneumatic actuators shall be installed by the damper manufacturer at time of damper fabrication. Electric actuators shall have been energized hold open tested for a period of at least 1 year with no spring return failures.

Each fire smoke damper shall be equipped with a "controlled closure" quick detect heat-actuated release device to prevent duct and HVAC component damage. Instantaneous damper closure through the use of fusible links is unacceptable.

Damper frame (when size permits) shall be constructed using the UniFrame Design Concept (UDC) and shall be a roll-formed structural hat channel, reinforced at the corners, formed from a single piece of minimum 16 gage (1.6) galvanized steel. Damper blades shall be airfoil shaped with 13 gage (2.3) equivalent thickness formed from a single piece of galvanized steel. Bearings shall be stainless steel turning in an extruded hole in the frame. Blade edge seals shall be silicone rubber and galvanized steel mechanically locked in to the blade edge (adhesive type seals are not acceptable). Each damper shall be supplied with a factory mounted sleeve of 17" (432) minimum length. Dampers shall be Ruskin model FSD60.

(Consult Ruskin for detailed CSI *MasterFormat* Specification).

# RUSKIN®

3900 Dr. Greaves Rd.  
Kansas City, MO 64030  
(816) 761-7476  
FAX (816) 765-8955  
www.ruskin.com