

# RESTAURANT EXHAUST FANS

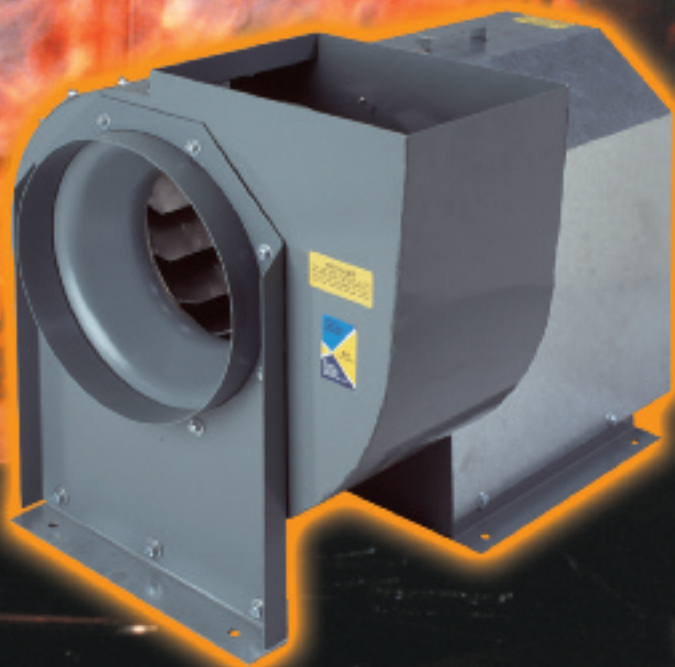

## CENTRAL BLOWER COMPANY

211 S. 7th Ave. • City of Industry, CA 91746  
(626) 330-3182 Fax (626) 330-9406  
[www.centralblower.com](http://www.centralblower.com)

CATALOG REF-11  
OCTOBER 2011

# CENTRAL C

## Series RE

### Scoop with Grease Trough

- ▲ Sealed to blower housing with high temperature silicone foam
- ▲ Grease trough easily removed for draining
- ▲ Drain on grease trough allows rain water to run off while grease stays inside
- ▲ Can be extended up or out for special applications
- ▲ Scoop can be removed for extended discharge

### Tilt Open Top Cover Assembly

- ▲ Heavy duty self cleaning backward inclined wheel
- ▲ Drives stay in adjustment when open for service
- ▲ Sealed to blower housing with high temperature silicone foam
- ▲ Heavy duty relubricatable bearings
- ▲ Latch locks cover open when cleaning
- ▲ Spare belt stored under weather cover

### Safety Disconnect Switch

- ▲ Standard (specify H.P., voltage and phase)
- ▲ Weather proof enclosure
- ▲ Factory wired to motor

### Blower Housing

- ▲ Heavy gauge zinc coated steel
- ▲ U.L. recognized powder coating
- ▲ Housing continuously welded top and bottom



Central Blower Co. certifies that the Belt Drive Blowers shown on pages 2 through 15 are licensed to bear the AMCA Seal. The ratings shown are based on tests and procedures performed in accordance with AMCA Publication 211 and comply with the requirements of AMCA Certified Ratings Program.

**CENTRAL**

**C**

## Series RE Features

### Standard Weather Cover

- ▲ Heavy gauge zinc coated steel
- ▲ Painted with UL recognized paint
- ▲ Easily removed with simple hand tools

### Optional Funnel Fitting

- ▲ All welded
- ▲ Specify duct size when ordering
- ▲ Side inlet fitting available. See factory for price.

### Vented Curb

- ▲ Galvanized Steel
- ▲ Welded
- ▲ Proper Height to place discharge 40" from roof
- ▲ Wood nailer for roofing
- ▲ One pc. curb allows roofing and duct installation before blower arrives

### Hinge Kit with Prop Rod

- ▲ Cannot close without operator release

### Motors

- ▲ Quality US made
- ▲ Energy efficient
- ▲ Sized to fit CFM requirements
- ▲ Mounted outside away from heat & grease

### Drives

- ▲ Highest quality
- ▲ Cast iron for long life
- ▲ Variable pitch motor pulley allows speed adjustment in the field

### Bearings

- ▲ Highest quality
- ▲ HD cast housing with lube fitting for maintenance
- ▲ Ground and Polished shafts with keys

# Restaurant Exhaust Fans

## RE 12-24

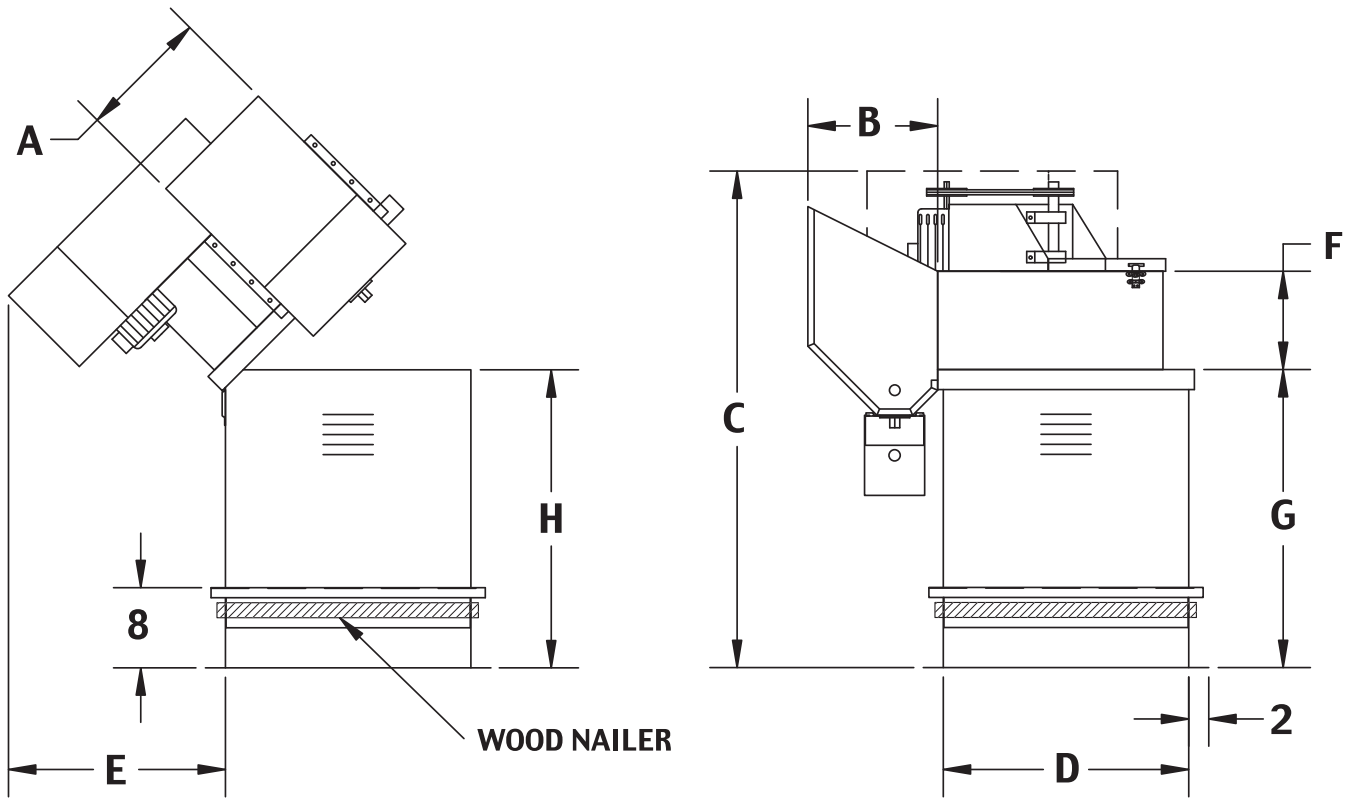

Model	A	B	C	D	E	F	G	H
RE-12	13 1/8	13 1/4	49 1/8	24 1/2	20	9 3/4	30 1/4	29 3/4
RE-15	15	16 3/4	53 7/8	24 1/2	22	12 1/8	30 1/4	29 3/4
RE-18	19 5/8	19 1/4	53	39 7/8	25	14 1/2	26 1/2	26
RE-22	23 13/16	23 1/2	58 1/2	39 7/8	28	17 13/16	26 1/2	26
RE-24	26 1/4	25 7/8	57 1/4	47	30	19 1/2	21 1/2	21

# Restaurant Exhaust Fans

Models RE12, RE15, RE18, RE22 and RE24

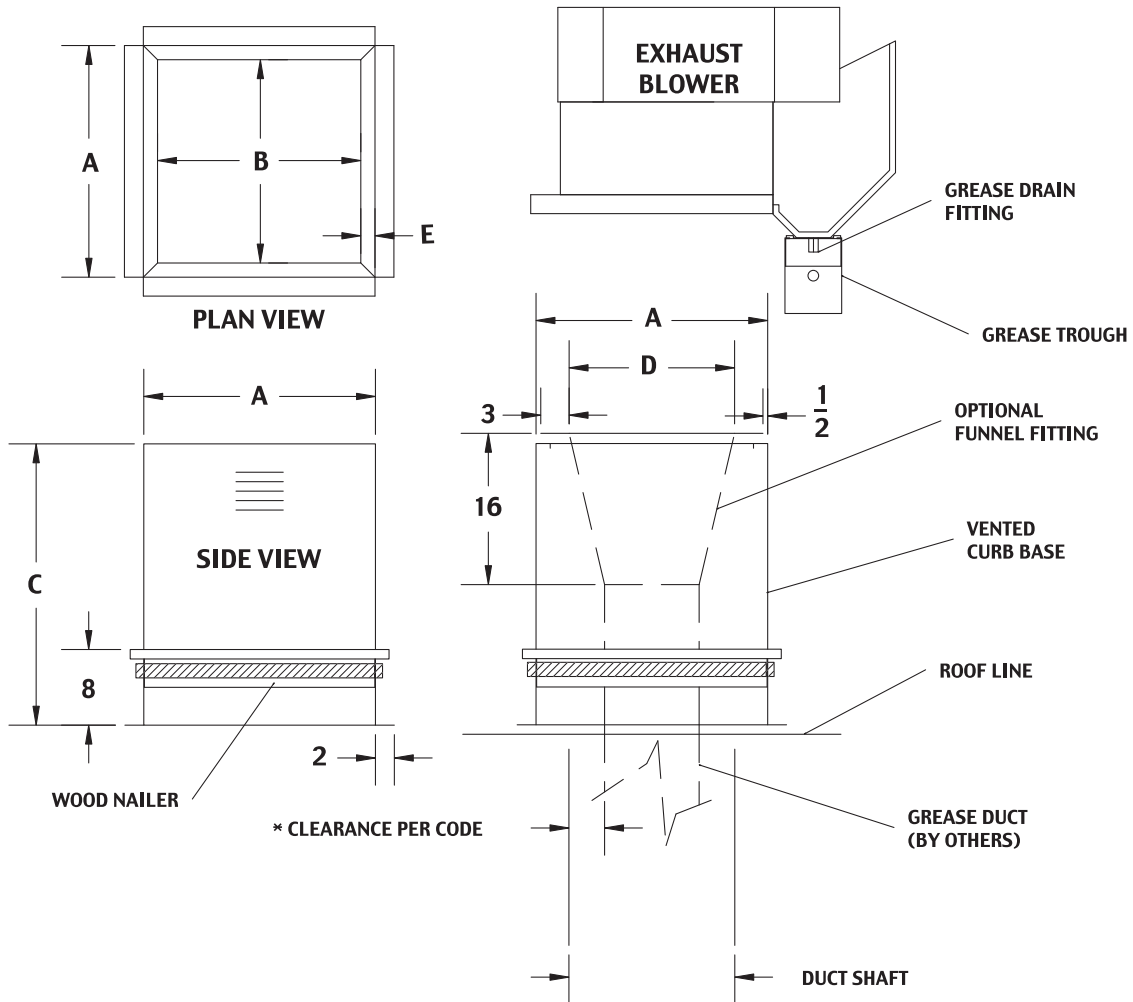

## INSTALLATION PROCEDURE

1. LOOSEN HINGE BOLT SECURING BLOWER TO BASE, SET BASE ON ROOF.
2. DROP GREASE DUCT ON BASE THROUGH OPENING IN BASE. FLANGE ON DUCT WILL SET ON LIP OF BASE TO HOLD DUCT IN PLACE
3. SET BLOWER ON BASE AND TIGHTEN BOLTS THAT SECURE HINGES TO BASE.

Model	A	B	C	D	E
RE-12	24 1/2	21 1/2	29 3/4	17 1/2	1 1/2
RE-15	24 1/2	21 1/2	29 3/4	17 1/2	1 1/2
RE-18	39 7/8	36 7/8	26	33	1 1/2
RE-22	39 7/8	36 7/8	26	33	1 1/2
RE-24	47	43	21	40	2

## RE-12 12.25" Wheel Diameter

VOLUME CFM	Outlet Velocity FPM	SP, in. WG																					
		1/8"		1/4"		3/8"		1/2"		3/4"		1.0"		1-1/4"		1-1/2"		2.0"		2-1/2"		3.0"	
		RPM	BHP	RPM	BHP	RPM	BHP	RPM	BHP	RPM	BHP	RPM	BHP	RPM	BHP	RPM	BHP	RPM	BHP	RPM	BHP	RPM	BHP
500	563	726	0.03	840	0.04	939	0.06	1034	.008	1210	0.13	1372	0.18	1518	0.23	1650	0.29	1887	0.40	2100	0.56	2296	0.68
600	675	824	0.04	928	0.06	1019	0.08	1102	0.10	1259	0.14	1405	0.20	1548	0.26	1676	0.32	1912	0.45	2120	0.59	2306	0.74
700	788	926	0.06	1021	0.08	1104	0.10	1182	0.12	1323	0.17	1459	0.22	1581	0.28	1710	0.35	1938	0.50	2144	0.65	2332	0.80
800	900	1031	0.08	1116	0.10	1196	0.13	1268	0.15	1402	0.20	1520	0.26	1641	0.31	1752	0.38	1971	0.54	2171	0.70	2358	0.87
900	1013	1132	0.10	1217	0.13	1289	0.16	1359	0.19	1482	0.24	1600	0.30	1703	0.36	1812	0.42	2008	0.58	2205	0.75	2388	0.94
1000	1125	1240	0.13	1321	0.17	1387	0.19	1452	0.23	1570	0.29	1681	0.35	1783	0.42	1878	0.48	2078	0.63	2243	0.81	2420	1.02
1200	1350	1463	0.22	1529	0.26	1592	0.29	1646	0.33	1758	0.40	1854	0.47	1947	0.54	2039	0.62	2205	0.78	2362	0.94	2519	1.13
1400	1575	1684	0.34	1738	0.37	1800	0.42	1852	0.46	1948	0.54	2041	0.63	2129	0.71	2208	0.79	2365	0.98	2512	1.16	2643	1.35
1600	1800	1910	0.50	1961	0.54	2005	0.57	2062	0.63	2150	0.72	2232	0.82	2316	0.92	2393	1.01	2535	1.19	2672	1.41	2805	1.62

## RE-15 15.00" Wheel Diameter

VOLUME CFM	Outlet Velocity FPM	SP, in. WG																					
		1/8"		1/4"		3/8"		1/2"		3/4"		1.0"		1-1/4"		1-1/2"		2.0"		2-1/2"		3.0"	
		RPM	BHP	RPM	BHP	RPM	BHP	RPM	BHP	RPM	BHP	RPM	BHP	RPM	BHP	RPM	BHP	RPM	BHP	RPM	BHP	RPM	BHP
800	633	624	0.05	701	0.07	798	0.09	870	0.12	986	0.17	1110	0.23	1228	0.31	1334	0.38	1522	0.54	1689	0.70	1841	0.87
1000	792	739	0.08	817	0.10	891	0.13	954	0.16	1075	0.22	1171	0.28	1263	0.35	1362	0.43	1551	0.62	1717	0.81	1868	1.00
1200	950	855	0.12	921	0.15	988	0.18	1052	0.22	1157	0.28	1260	0.36	1345	0.43	1422	0.51	1581	0.68	1747	0.90	1897	1.12
1400	1108	973	0.18	1036	0.21	1090	0.25	1149	0.29	1254	0.37	1341	0.44	1434	0.54	1513	0.62	1650	0.79	1781	0.98	1925	1.22
1600	1267	1095	0.24	1152	0.29	1202	0.33	1250	0.37	1351	0.47	1440	0.56	1517	0.64	1596	0.74	1740	0.94	1859	1.14	1973	1.34
1800	1425	1218	0.32	1270	0.38	1318	0.44	1361	0.48	1449	0.58	1537	0.69	1616	0.79	1685	0.88	1825	1.10	1950	1.33	2058	1.55
2000	1584	1342	0.44	1387	0.51	1435	0.50	1478	0.61	1552	0.71	1634	0.84	1712	0.95	1783	1.05	1908	1.28	2036	1.53	2149	1.79
2200	1742	1465	0.60	1510	0.65	1552	0.70	1593	0.76	1664	0.87	1734	0.99	1810	1.12	1880	1.25	2006	1.50	2117	1.74	2233	2.02
2400	1900	1589	0.77	1633	0.79	1669	0.89	1710	0.93	1780	1.07	1842	1.18	1908	1.32	1978	1.46	2103	1.75	2213	2.01	2314	2.27

## RE-18 18.25" Wheel Diameter

VOLUME CFM	Outlet Velocity FPM	SP, in. WG																					
		1/8"		1/4"		3/8"		1/2"		3/4"		1.0"		1-1/4"		1-1/2"		2.0"		2-1/2"		3.0"	
		RPM	BHP	RPM	BHP	RPM	BHP	RPM	BHP	RPM	BHP	RPM	BHP	RPM	BHP	RPM	BHP	RPM	BHP	RPM	BHP	RPM	BHP
1400	708	591	0.11	658	0.14	715	0.17	768	0.22	868	0.30	958	0.40	1043	0.50	1123	0.62	1277	0.88	1415	1.15	1539	1.41
1600	810	654	0.14	717	0.17	773	0.22	820	0.26	913	0.36	998	0.46	1077	0.56	1152	0.68	1295	0.95	1430	1.24	1556	1.55
1800	911	718	0.17	780	0.24	830	0.27	879	0.33	962	0.41	1044	0.53	1119	0.64	1189	0.76	1323	1.03	1449	1.33	1570	1.66
2000	1012	783	0.22	842	0.30	889	0.32	936	0.39	1017	0.49	1091	0.60	1163	0.73	1231	0.85	1358	1.13	1477	1.43	1591	1.77
2200	1113	849	0.29	905	0.37	952	0.43	995	0.46	1074	0.59	1143	0.69	1211	0.82	1277	0.96	1398	1.25	1511	1.55	1620	1.89
2400	1214	916	0.35	969	0.44	1016	0.53	1055	0.57	1132	0.69	1200	0.82	1262	0.93	1323	1.07	1441	1.37	1550	1.69	1654	2.04
2600	1316	983	0.45	1032	0.51	1079	0.63	1119	0.70	1190	0.79	1258	0.95	1318	1.08	1375	1.20	1488	1.52	1593	1.85	1692	2.19
2800	1417	1051	0.59	1097	0.61	1142	0.73	1182	0.84	1248	0.90	1316	1.09	1376	1.25	1430	1.36	1536	1.67	1639	2.03	1735	2.39
3000	1518	1121	0.73	1162	0.75	1205	0.84	1245	0.97	1311	1.11	1374	1.22	1433	1.42	1487	1.56	1587	1.85	1686	2.21	1780	2.59
3200	1619	1190	0.86	1230	0.87	1269	0.94	1309	1.11	1375	1.31	1432	1.35	1491	1.58	1545	1.77	1641	2.06	1735	2.41	1827	2.81
3400	1720	1259	0.99	1296	1.00	1333	1.08	1371	1.25	1437	1.51	1495	1.62	1549	1.75	1603	1.97	1699	2.33	1787	2.63	1873	3.03
3600	1822	1327	1.14	1363	1.15	1400	1.28	1435	1.38	1501	1.72	1558	1.89	1607	1.92	1660	2.17	1757	2.60	1841	2.91	1925	3.30

Performance certified is for Installation Type B - Free Inlet, Ducted Outlet.  
 Power rating (BHP) does not include transmission losses.  
 Performance ratings include the effects of a discharge scoop.

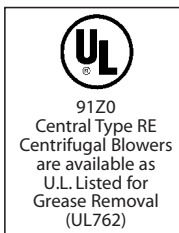

Central Blower Co. certifies that the Belt Drive Blowers shown on pages 2 through 15 are licensed to bear the AMCA Seal. The ratings shown are based on tests and procedures performed in accordance with AMCA Publication 211 and comply with the requirements of AMCA Certified Ratings Program.

# RE-22 22.25" Wheel Diameter

VOLUME CFM	Outlet Velocity FPM	SP, in. WG																							
		1/8"		1/4"		3/8"		1/2"		3/4"		1.0"		1-1/4"		1-1/2"		2.0"		2-1/2"		3.0"			
		RPM	BHP	RPM	BHP	RPM	BHP	RPM	BHP	RPM	BHP	RPM	BHP	RPM	BHP	RPM	BHP	RPM	BHP	RPM	BHP	RPM	BHP	RPM	BHP
2200	756	475	0.14	534	0.20	586	0.26	633	0.32	722	0.47	804	0.63	879	0.81	949	1.00	1077	1.41	1193	1.84	1299	2.30		
2400	824	508	0.17	564	0.23	612	0.30	658	0.36	742	0.51	821	0.68	895	0.86	962	1.06	1088	1.48	1202	1.94	1306	2.42		
2600	893	541	0.21	593	0.27	640	0.34	684	0.41	764	0.57	839	0.74	910	0.92	978	1.13	1099	1.56	1212	2.04	1315	2.53		
2800	962	574	0.25	624	0.32	669	0.39	711	0.47	788	0.62	860	0.80	928	0.99	993	1.20	1113	1.64	1223	2.13	1325	2.65		
3000	1031	608	0.29	655	0.37	699	0.45	739	0.53	814	0.69	882	0.87	948	1.07	1010	1.27	1129	1.73	1235	2.23	1335	2.76		
3200	1100	642	0.34	687	0.42	729	0.51	768	0.59	840	0.76	906	0.95	969	1.15	1030	1.36	1144	1.82	1250	2.33	1348	2.88		
3400	1168	677	0.40	719	0.49	759	0.57	798	0.66	867	0.84	931	1.03	991	1.24	1050	1.46	1161	1.93	1266	2.45	1361	3.00		
3600	1239	712	0.47	752	0.56	790	0.65	827	0.74	895	0.93	957	1.13	1015	1.34	1072	1.56	1180	2.04	1281	2.56	1377	3.13		
3800	1306	747	0.54	785	0.63	822	0.73	857	0.83	923	1.03	984	1.23	1041	1.45	1095	1.67	1200	2.16	1298	2.69	1393	3.27		
4000	1374	782	0.62	819	0.72	864	0.82	888	0.92	953	1.13	1011	1.34	1067	1.56	1119	1.79	1221	2.29	1316	2.83	1408	3.41		
4200	1443	818	0.70	853	0.81	886	0.91	919	1.02	982	1.24	1039	1.46	1093	1.69	1145	1.93	1243	2.43	1336	2.98	1425	3.57		
4400	1512	853	0.80	887	0.91	919	1.02	951	1.13	1012	1.36	1068	1.59	1121	1.82	1171	2.07	1266	2.58	1357	3.14	1444	3.73		
4600	1581	889	0.90	921	1.01	953	1.13	983	1.24	1042	1.48	1097	1.73	1148	1.97	1198	2.22	1290	2.74	1378	3.31	1464	3.92		
4800	1649	925	1.02	956	1.13	986	1.25	1015	1.37	1072	1.62	1127	1.87	1177	2.12	1225	2.38	1316	2.92	1401	3.49	1485	4.11		
5000	1718	961	1.14	991	1.26	1020	1.38	1048	1.51	1103	1.76	1157	2.03	1206	2.29	1253	2.55	1342	3.11	1425	3.69	1506	4.31		
5200	1787	997	1.27	1026	1.40	1054	1.52	1081	1.65	1135	1.91	1186	2.19	1235	2.46	1281	2.74	1368	3.30	1450	3.90	1528	4.52		
5400	1856	1033	1.41	1061	1.54	1088	1.67	1115	1.81	1166	2.08	1217	2.36	1265	2.65	1310	2.93	1395	3.51	1475	4.12	1552	4.75		
5600	1924	1069	1.56	1096	1.70	1122	1.84	1148	1.97	1198	2.25	1247	2.54	1295	2.84	1339	3.14	1422	3.73	1502	4.35	1576	5.00		
5800	1993	1105	1.73	1131	1.87	1157	2.01	1182	2.15	1231	2.44	1278	2.74	1324	3.04	1369	3.35	1450	3.96	1528	4.60	1601	5.26		

# RE-24 24.50" Wheel Diameter

VOLUME CFM	Outlet Velocity FPM	SP, in. WG																							
		1/8"		1/4"		3/8"		1/2"		3/4"		1.0"		1-1/4"		1-1/2"		2.0"		2-1/2"		3.0"			
		RPM	BHP	RPM	BHP	RPM	BHP	RPM	BHP	RPM	BHP	RPM	BHP	RPM	BHP	RPM	BHP	RPM	BHP	RPM	BHP	RPM	BHP	RPM	BHP
2800	793	405	0.19	466	0.28	523	0.38	577	0.48	672	0.70	752	0.90	822	1.05	887	1.22	1010	1.77	1118	2.39	1212	2.98		
3200	907	447	0.25	499	0.34	551	0.46	602	0.57	694	0.82	774	1.08	845	1.30	908	1.48	1023	1.85	1131	2.50	1229	3.19		
3600	1020	490	0.33	537	0.43	585	0.55	629	0.67	718	0.94	796	1.22	867	1.51	931	1.78	1043	2.18	1145	2.60	1243	3.31		
4000	1133	534	0.44	576	0.54	619	0.65	662	0.78	742	1.08	818	1.38	888	1.69	953	2.01	1066	2.58	1165	3.01	1256	3.42		
4400	1246	580	0.61	618	0.68	657	0.78	696	0.92	769	1.21	843	1.55	910	1.88	974	2.24	1088	2.94	1188	3.50	1277	3.99		
4800	1360	628	0.85	660	0.79	696	0.93	732	1.08	803	1.40	868	1.72	935	2.09	996	2.46	1110	3.24	1210	3.99	1300	4.58		
5200	1473	675	1.09	705	0.99	738	1.12	770	1.16	837	1.60	898	1.93	960	2.31	1021	2.71	1132	3.53	1232	4.37	1322	5.18		
5600	1586	723	1.32	749	1.18	779	1.32	810	1.49	871	1.81	931	2.18	986	2.54	1046	2.98	1153	3.82	1254	4.73	1344	5.62		
6000	1700	771	1.58	794	1.42	822	1.54	852	1.73	908	2.07	965	2.45	1019	3.84	1071	3.23	1178	4.17	1275	5.10	1368	6.08		
6400	1813	818	1.81	842	1.92	867	1.83	893	1.99	946	2.34	999	2.74	1053	3.17	1103	3.58	1204	4.52	1298	5.50	1388	6.52		
6800	1926	866	2.06	889	2.50	911	2.11	935	2.26	986	2.68	1036	3.08	1087	3.51	1136	3.95	1229	4.88	1323	5.93	1409	6.96		
7200	2040	914	2.32	937	2.89	955	2.30	979	2.63	1027	3.06	1074	3.42	1121	3.86	1170	4.35	1257	5.28	1348	6.37	1434	7.45		
7600	2153	961	2.54	985	3.38	1003	3.08	1024	3.01	1069	3.42	1112	3.80	1158	4.29	1204	4.48	1291	5.78	1374	6.80	1459	8.00		
8000	2266	1008	2.78	1032	3.85	1050	3.81	1068	3.39	1111	3.82	1153	4.30	1196	4.72	1238	5.20	1325	6.27	1401	7.29	1485	8.51		

Performance certified is for Installation Type B - Free Inlet, Ducted Outlet.  
 Power rating (BHP) does not include transmission losses.  
 Performance ratings include the effects of a discharge scoop.

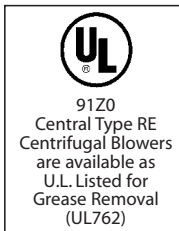

Central Blower Co. certifies that the Belt Drive Blowers shown on pages 2 through 15 are licensed to bear the AMCA Seal. The ratings shown are based on tests and procedures performed in accordance with AMCA Publication 211 and comply with the requirements of AMCA Certified Ratings Program.



# Series BI UL

## Backward Inclined Blowers for Restaurant Exhaust

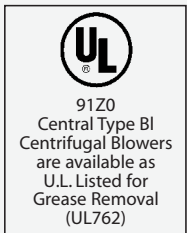
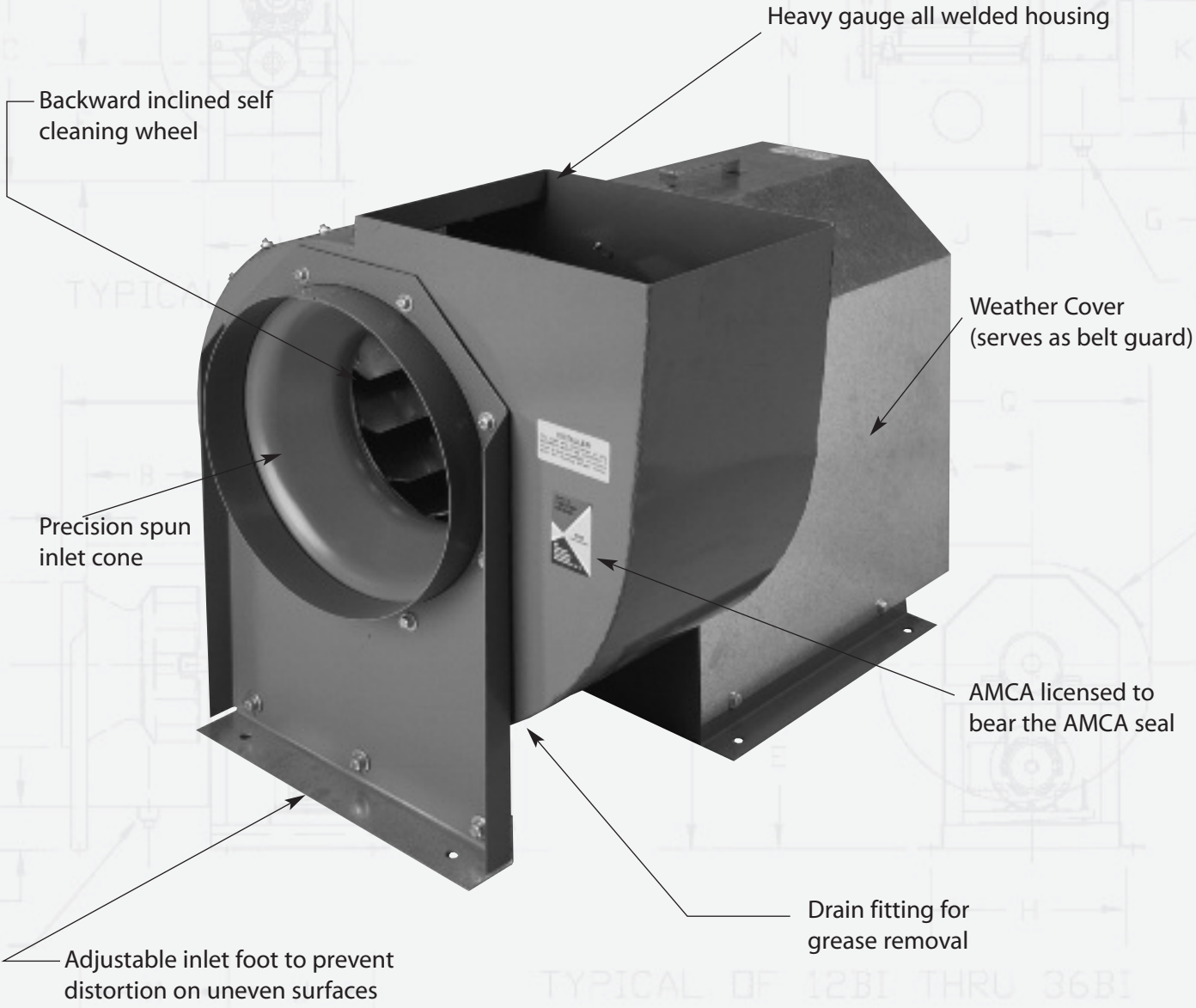

Central Blower Co. certifies that the Belt Drive Blowers shown on pages 2 through 15 are licensed to bear the AMCA Seal. The ratings shown are based on tests and procedures performed in accordance with AMCA Publication 211 and comply with the requirements of AMCA Certified Ratings Program.



**CENTRAL**

**C**

## Series BI UL Features

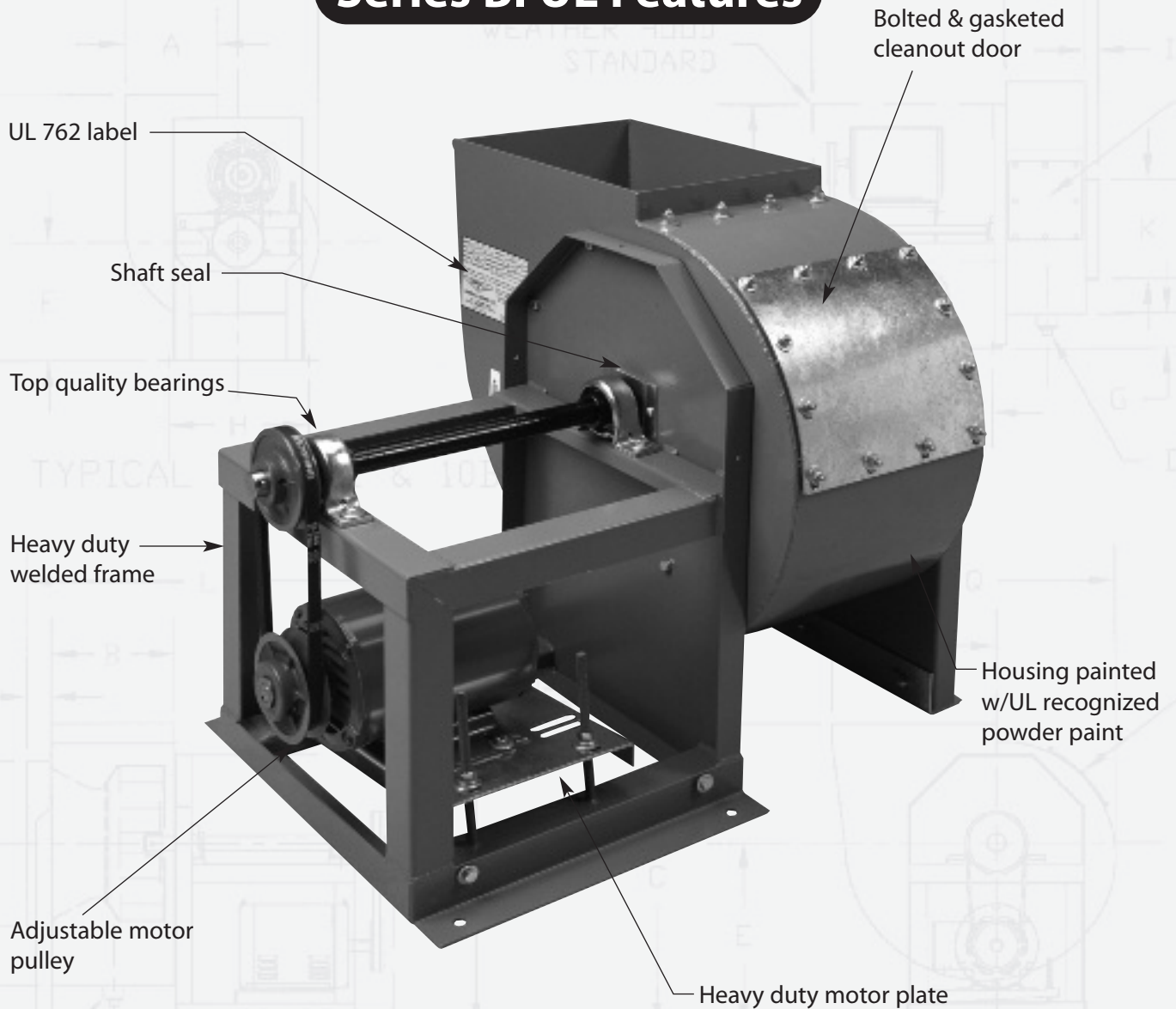

### Motors

- ▲ Quality US made
- ▲ Sized to fit CFM requirements
- ▲ Mounted outside, away from heat and grease

### Drives

- ▲ Quality US made
- ▲ Cast iron for long life
- ▲ Variable pitch motor pulley for speed adjustment

### Bearings

- ▲ Highest quality
- ▲ Rubber isolated for quiet operation

# Series BI UL

## Backward Inclined Blowers for Restaurant Exhaust

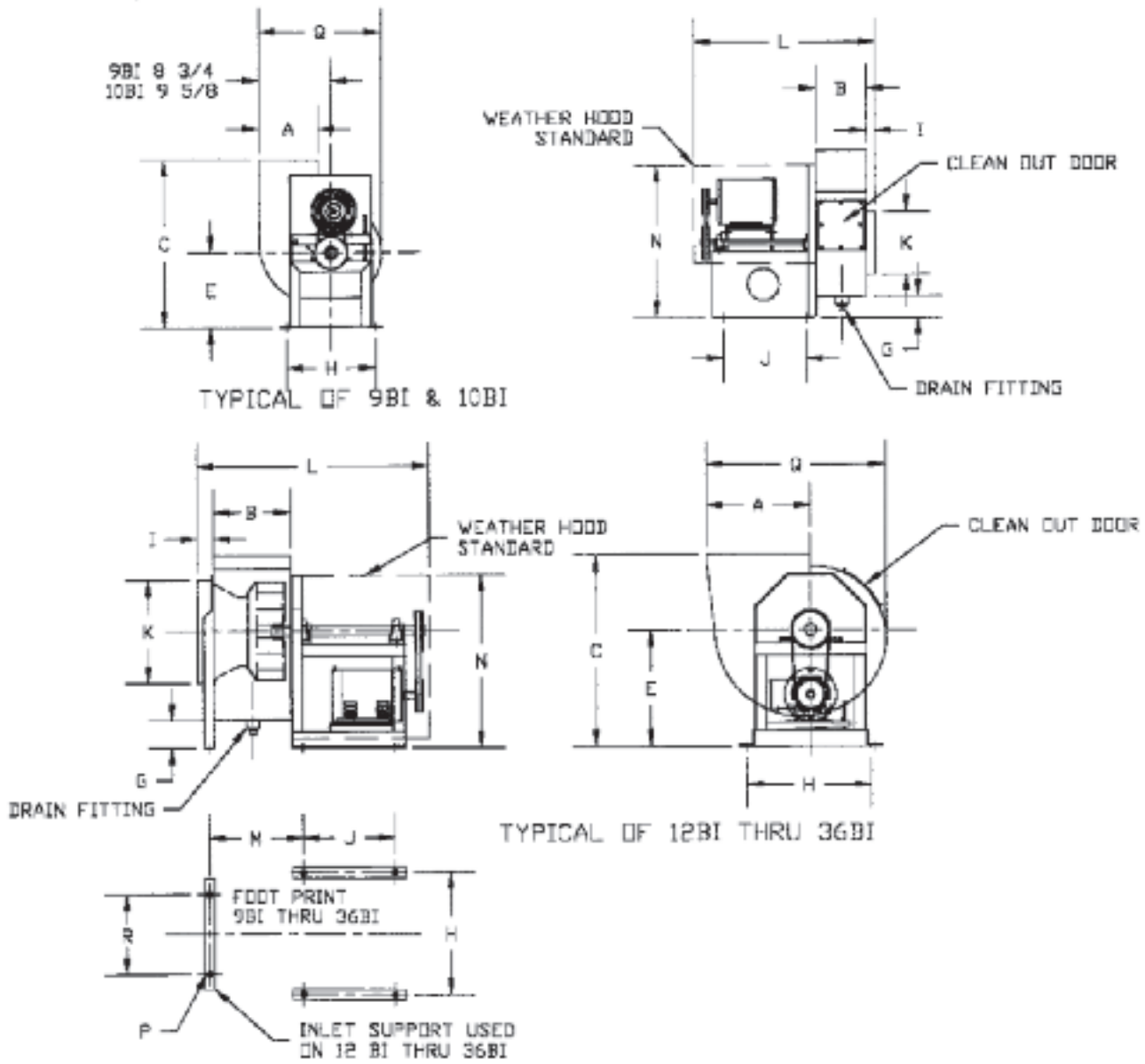

**Dimensional Table**

MODEL NO.	WHEEL DIA.	A	B	C	E	G	H	I	J	K	L	M	N	P	Q	R	SHAFT DIA.
9 BI	9 3/16	7 1/2	6 11/32	20 1/8	9 3/8	1 11/16	11 3/8	1 3/4	10 1/2	7 7/8	23		19 1/4	3/8	15 3/8		5/8
10 BI	10 5/8	8 3/16	8 3/16	23 3/16	10 1/4	1 9/16	13	1 3/4	11	9 7/8	26 1/2		21 3/4	3/8	17 3/16		3/4
12 BI	12 1/4	13 1/8	9 13/16	24 1/16	14 5/8	3 11/16	16	1 3/4	11 1/2	13	29	11 3/4	21 3/4	7/16	22 5/8	11	1
15 BI	15	16 1/8	12	29 1/8	17 5/8	4 1/4	19	2	12 1/2	15 7/8	32	14 1/8	26 1/4	9/16	27 5/8	14	1
18 BI	18 1/4	19 9/16	14 5/8	35 1/2	21 1/2	5 1/4	22 5/8	2	15 5/16	19 5/16	38 1/8	16 7/8	31 7/8	9/16	33 5/8	18	1 3/16
20 BI	20	21 7/16	15 15/16	38 7/8	23 1/2	5 23/32	22 5/8	2 3/16	15 5/16	21 3/16	39 7/16	18 3/16	33 7/8	9/16	36 7/8	22 5/8	1 3/16
22 BI	22 1/4	23 13/16	17 13/16	42 7/8	25 7/8	6 1/16	26 1/8	2 1/4	16 1/2	23 1/2	43 15/16	20 1/8	37 15/16	9/16	40 15/16	20	1 3/16
24 BI	24 1/2	26 3/16	19 5/8	49 9/16	27 7/8	6 1/8	26 1/8	2 1/4	16 1/2	25 7/8	45 1/16	21 15/16	39 15/16	9/16	45 15/16	26 1/8	1 3/16
27 BI	27	29	21 5/8	52	31 1/4	7 1/4	30 3/8	2 1/4	18 3/8	28 9/16	49 1/8	24 1/4	45 27/32	9/16	49 13/16	24	1 7/16
30 BI	30	32 3/16	24	59 1/4	36 1/4	9 1/2	39	2	20 11/16	31 1/2	58	26 15/16	54 1/4	9/16	55 1/2	39	1 11/16
36 BI	36 1/2	39 1/8	29 3/16	71 3/8	43 7/8	11 3/8	47	2	22 7/8	38 5/8	70	31 9/16	65 7/8	9/16	67 3/16	47	1 15/16

# 9-BI

9 3/16-INCH WHEEL DIAMETER  
OUTLET AREA (SQ. FT.) .33

TIP SPEED (FPM) = 2.41 x RPM  
MAX. BHP = .0205 x (RPM/1000)<sup>3</sup>

VOLUME CFM	O.V. FPM	SP, in. WG													
		1/4" RPM BHP	3/8" RPM BHP	1/2" RPM BHP	5/8" RPM BHP	3/4" RPM BHP	1.0" RPM BHP	1-1/4" RPM BHP	1-1/2" RPM BHP	1-3/4" RPM BHP	2.0" RPM BHP	2-1/2" RPM BHP	3.0" RPM BHP	3-1/2" RPM BHP	
100	297	875 0.01	1054 0.01	1206 0.02	1343 0.03	1467 0.04	1690 0.05	1887 0.07	2067 0.09	2233 0.11	2388 0.14	2672 0.19	2930 0.24	3167 0.30	
200	593	1012 0.02	1172 0.02	1307 0.03	1429 0.04	1543 0.05	1750 0.07	1937 0.09	2107 0.12	2265 0.14	2413 0.17	2685 0.22	2934 0.28	3164 0.35	
300	890	1200 0.03	1333 0.04	1459 0.05	1575 0.06	1683 0.07	1874 0.09	2044 0.12	2202 0.15	2350 0.18	2491 0.21	2753 0.27	2993 0.34	3215 0.41	
400	1187	1429 0.05	1541 0.07	1645 0.08	1745 0.09	1842 0.10	2024 0.13	2190 0.16	2345 0.19	2484 0.22	2615 0.25	2859 0.32	3085 0.40	3298 0.48	
500	1481	1673 0.08	1774 0.10	1866 0.12	1953 0.13	2036 0.15	2196 0.18	2349 0.21	2495 0.25	2632 0.28	2762 0.32	3002 0.40	3217 0.48	3418 0.56	
600	1781	1929 0.13	2018 0.15	2102 0.17	2183 0.19	2257 0.21	2399 0.24	2535 0.28	2666 0.31	2794 0.36	2919 0.40	3149 0.48	3365 0.57	3565 0.66	
700	2077	2193 0.18	2272 0.21	2348 0.23	2421 0.26	2492 0.29	2623 0.33	2746 0.37	2865 0.40	2980 0.45	3092 0.49	3311 0.59	3517 .069	3711 0.79	
800	2374	2462 0.26	2533 0.29	2602 .0.31	2668 0.34	2733 0.37	2858 0.43	2973 0.48	3082 0.52	3187 0.57	3291 0.61	3490 0.71	3683 0.82	3871 0.93	
900	2671	2735 0.36	2800 0.38	2862 0.41	2923 0.44	2983 0.48	3098 0.54	3208 0.61	3312 0.67	3410 0.72	3506 0.76	3691 0.86	3869 0.97	4042 1.09	
1000	2967	3011 0.47	3070 0.50	3128 0.54	3184 0.57	3239 0.60	3345 0.68	3448 0.75	3548 0.82	3643 0.89	3732 0.95	3905 1.06	4072 1.16	4234 1.28	
1100	3264	3289 0.62	3344 0.65	3397 0.68	3449 0.72	3500 0.76	3599 0.83	3695 0.91	3789 0.99	3879 1.08	3968 1.15	4131 1.28	4288 1.40	4441 1.52	

# 10-BI

10 5/8-INCH WHEEL DIAMETER  
OUTLET AREA (SQ. FT.) .452

TIP SPEED (FPM) = 2.78 x RPM  
MAX. BHP = .0283 x (RPM/1000)<sup>3</sup>

VOLUME CFM	O.V. FPM	SP, in. WG													
		1/4" RPM BHP	3/8" RPM BHP	1/2" RPM BHP	5/8" RPM BHP	3/4" RPM BHP	1.0" RPM BHP	1-1/4" RPM BHP	1-1/2" RPM BHP	1-3/4" RPM BHP	2.0" RPM BHP	2-1/2" RPM BHP	3.0" RPM BHP	3-1/2" RPM BHP	
200	442	812 0.02	965 0.03	1098 0.04	1212 0.05	1322 0.06	1521 0.09	1698 0.12	1857 0.15	2002 0.19	2140 0.23	2389 0.31	2611 0.40	2820 0.50	
300	664	901 0.02	1041 0.04	1161 0.05	1269 0.06	1373 0.08	1561 0.11	1725 0.14	1873 0.18	2019 0.22	2153 0.26	2403 0.35	2629 0.45	2833 0.55	
400	885	1000 0.03	1134 0.05	1251 0.06	1357 0.08	1450 0.09	1623 0.13	1779 0.17	1929 0.21	2067 0.25	2193 0.30	2425 0.39	2642 0.50	2850 0.61	
500	1106	1121 0.05	1233 0.07	1345 0.08	1449 0.10	1541 0.12	1710 0.16	1859 0.20	1995 0.24	2123 0.29	2248 0.34	2481 0.44	2692 0.55	2885 0.67	
600	1327	1259 0.07	1358 0.09	1451 0.11	1546 0.13	1636 0.15	1801 0.19	1950 0.23	2082 0.28	2207 0.33	2321 0.38	2540 0.49	2746 0.61	2941 0.73	
700	1548	1404 0.10	1491 0.12	1577 0.14	1659 0.16	1739 0.18	1896 0.23	2041 0.28	2173 0.33	2298 0.38	2411 0.44	2621 0.55	2817 0.68	2998 0.81	
800	1720	1559 0.14	1634 0.16	1710 0.18	1785 0.21	1859 0.23	2000 0.28	2136 0.33	2268 0.38	2388 0.44	2502 0.50	2711 0.62	2901 0.75	3075 0.89	
900	1991	1715 0.19	1785 0.21	1852 0.24	1920 0.26	1986 0.28	2118 0.34	2240 0.39	2362 0.45	2482 0.51	2596 0.57	2801 0.70	2993 0.84	3167 0.98	
1000	2212	1876 0.25	1940 0.27	2001 0.30	2061 0.32	2123 0.35	2241 0.40	2358 0.46	2469 0.53	2582 0.59	2690 0.66	2895 0.79	3083 0.94	3259 1.09	
1200	2654	2203 0.40	2259 0.43	2309 0.46	2364 0.49	2412 0.52	2516 0.58	2613 0.65	2713 0.72	2811 0.79	2903 0.86	3092 1.01	3272 1.17	3442 1.34	
1400	3097	2539 0.61	2583 0.65	2630 0.68	2675 0.71	2721 0.75	2809 0.82	2898 0.89	2983 0.97	3069 1.04	3152 1.13	3318 1.29	3478 1.47	3639 1.64	
1600	3539	2874 0.89	2916 0.93	2955 0.97	2998 1.01	3039 1.04	3118 1.12	3192 1.20	3269 1.29	3348 1.37	3420 1.46	3570 1.64	3718 1.83	3858 2.02	

# 12-BI

12 1/4-INCH WHEEL DIAMETER  
OUTLET AREA (SQ. FT.) .855

TIP SPEED (FPM) = 3.21 x RPM  
MAX. BHP = .079 x (RPM/1000)<sup>3</sup>

VOLUME CFM	O.V. FPM	SP, in. WG													
		1/4" RPM BHP	3/8" RPM BHP	1/2" RPM BHP	5/8" RPM BHP	3/4" RPM BHP	1.0" RPM BHP	1-1/4" RPM BHP	1-1/2" RPM BHP	1-3/4" RPM BHP	2.0" RPM BHP	2-1/2" RPM BHP	3.0" RPM BHP	3-1/2" RPM BHP	
800	936	874 0.07	955 0.09	1032 0.11	1108 0.14	1183 0.17	1331 0.23	1467 0.30	1591 0.36	1708 0.42	1817 0.48	2020 0.61	2208 0.75	2383 0.91	
1000	1170	1012 0.11	1084 0.13	1150 0.16	1214 0.19	1275 0.22	1396 0.27	1516 0.35	1635 0.43	1748 0.51	1852 0.59	2048 0.75	2229 0.90	2396 1.06	
1200	1404	1160 0.15	1222 0.19	1283 0.22	1339 0.25	1393 0.28	1497 0.35	1598 0.42	1700 0.49	1800 0.58	1898 0.68	2091 0.88	2263 1.07	2426 1.25	
1400	1637	1313 0.22	1368 0.26	1422 0.29	1475 0.33	1524 0.37	1617 0.45	1708 0.53	1795 0.60	1881 0.68	1969 0.77	2140 0.98	2309 1.21	2469 1.44	
1600	1871	1470 0.30	1519 0.34	1567 0.38	1614 0.43	1661 0.47	1749 0.56	1830 0.65	1910 0.74	1988 0.83	2063 0.91	2216 1.10	2367 1.32	2515 1.58	
1800	2105	1631 0.41	1675 0.45	1718 0.50	1760 0.54	1802 0.59	1885 0.69	1963 0.79	2036 0.89	2107 0.99	2178 1.09	2313 1.29	2448 1.49	2584 1.73	
2000	2339	1793 0.54	1833 0.59	1872 0.64	1911 0.69	1949 0.74	2025 0.84	2099 0.95	2169 1.06	2235 1.17	2300 1.28	2427 1.51	2549 1.73	2670 1.95	
2200	2573	1956 0.69	1993 0.75	2030 0.80	2065 0.86	2101 0.91	2170 1.02	2238 1.14	2305 1.26	2370 1.38	2431 1.50	2549 1.75	2664 2.00	2775 2.24	
2400	2807	2121 0.87	2155 0.93	2189 0.99	2222 1.05	2255 1.11	2319 1.23	2382 1.36	2445 1.48	2506 1.61	2567 1.75	2678 2.01	2786 2.28	2892 2.56	
2600	3041	2287 1.09	2319 1.15	2350 1.22	2381 1.28	2411 1.35	2471 1.48	2530 1.61	2588 1.74	2646 1.88	2703 2.02	2812 2.31	2914 2.59	3014 2.89	
2800	3275	2453 1.34	2483 1.41	2512 1.48	2541 1.55	2570 1.62	2626 1.76	2681 1.90	2736 2.04	2790 2.19	2843 2.33	2949 2.64	3048 2.94	3142 3.25	
3000	3509	2620 1.62	2648 1.70	2675 1.77	2703 1.85	2729 1.92	2782 2.07	2835 2.22	2886 2.37	2937 2.53	2987 2.68	3087 3.00	3185 3.33	3276 3.66	

Performance certified is for Installation Type B - Free Inlet, Ducted Outlet.  
Power rating (BHP) does not include transmission losses.  
Performance ratings do not include the effects of appurtenances (accessories).

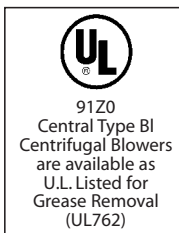

# 15-BI

15-INCH WHEEL DIAMETER  
OUTLET AREA (SQ. FT.) 1.282

TIP SPEED (FPM) = 3.93 x RPM  
MAX. BHP = .217 x (RPM/1000)<sup>3</sup>

VOLUME CFM	O.V. FPM	SP, in. WG													
		1/4" RPM BHP	3/8" RPM BHP	1/2" RPM BHP	5/8" RPM BHP	3/4" RPM BHP	1.0" RPM BHP	1-1/4" RPM BHP	1-1/2" RPM BHP	1-3/4" RPM BHP	2.0" RPM BHP	2-1/2" RPM BHP	3.0" RPM BHP	3-1/2" RPM BHP	
1000	780	675 0.07	764 0.10	845 0.13	921 0.17	992 0.20	1122 0.28	1244 0.37	1356 0.46	1462 0.56	1562 0.67	1742 0.88	1905 1.10	2055 1.33	
1100	858	706 0.08	790 0.11	869 0.15	941 0.18	1010 0.22	1137 0.30	1253 0.39	1363 0.48	1466 0.59	1563 0.69	1746 0.93	1908 1.16	2058 1.40	
1200	936	740 0.10	820 0.13	893 0.16	964 0.20	1030 0.24	1154 0.32	1266 0.41	1372 0.51	1473 0.61	1568 0.72	1747 0.96	1912 1.22	2061 1.47	
1400	1092	817 0.13	882 0.16	950 0.20	1015 0.24	1076 0.28	1192 0.37	1300 0.47	1401 0.57	1495 0.67	1586 0.79	1758 1.03	1917 1.30	2067 1.58	
1600	1248	899 0.17	956 0.21	1013 0.25	1072 0.29	1131 0.34	1239 0.43	1341 0.53	1436 0.64	1529 0.75	1615 0.87	1777 1.11	1931 1.38	2075 1.68	
1800	1404	985 0.22	1035 0.26	1085 0.30	1136 0.35	1189 0.40	1292 0.50	1388 0.60	1480 0.72	1566 0.83	1650 0.96	1807 1.22	1953 1.49	2092 1.78	
2000	1560	1072 0.28	1118 0.32	1163 0.37	1209 0.42	1255 0.47	1350 0.58	1441 0.69	1527 0.81	1611 0.93	1690 1.06	1842 1.33	1985 1.62	2117 1.92	
2200	1716	1161 0.35	1204 0.40	1245 0.45	1286 0.50	1327 0.55	1411 0.66	1499 0.79	1581 0.91	1660 1.04	1737 1.17	1882 1.45	2020 1.76	2151 2.08	
2400	1872	1251 0.43	1291 0.49	1330 0.54	1368 0.59	1405 0.65	1481 0.77	1558 0.89	1640 1.03	1714 1.17	1787 1.30	1928 1.59	2059 1.90	2186 2.24	
2600	2028	1342 0.53	1380 0.59	1416 0.65	1451 0.70	1486 0.76	1556 0.89	1626 1.02	1698 1.15	1773 1.30	1843 1.45	1976 1.75	2105 2.07	2226 2.41	
2800	2184	1433 0.64	1469 0.71	1504 0.77	1537 0.83	1570 0.89	1634 1.02	1699 1.16	1764 1.30	1831 1.45	1901 1.61	2030 1.93	2153 2.25	2272 2.60	
3000	2340	1525 0.77	1560 0.84	1592 0.91	1624 0.97	1655 1.04	1715 1.17	1775 1.32	1836 1.46	1897 1.61	1960 1.78	2088 2.12	2205 2.46	2319 2.81	
3200	2496	1618 0.92	1650 0.99	1682 1.06	1712 1.13	1741 1.20	1798 1.35	1855 1.49	1911 1.65	1968 1.80	2026 1.97	2145 2.32	2261 2.68	2370 3.05	
3400	2652	1711 1.08	1742 1.16	1772 1.23	1801 1.31	1829 1.38	1883 1.53	1937 1.69	1989 1.85	2043 2.01	2096 2.18	2206 2.53	2320 2.92	2426 3.30	
3600	2808	1804 1.26	1834 1.34	1862 1.42	1890 1.50	1917 1.58	1969 1.74	2020 1.90	2070 2.07	2120 2.24	2171 2.41	2272 2.78	2378 3.17	2486 3.59	
3800	2964	1898 1.47	1926 1.55	1954 1.64	1980 1.72	2006 1.80	2056 1.97	2105 2.14	2153 2.31	2200 2.49	2248 2.67	2343 3.04	2441 3.44	2542 3.86	
4000	3120	1991 1.69	2019 1.78	2045 1.87	2071 1.96	2096 2.05	2144 2.22	2191 2.40	2237 2.58	2282 2.76	2327 2.95	2417 3.34	2509 3.74	2603 4.16	
4200	3276	2086 1.94	2112 2.03	2137 2.13	2162 2.22	2186 2.31	2233 2.50	2278 2.68	2322 2.87	2365 3.06	2408 3.25	2494 3.65	2581 4.06	2669 4.49	

# 18-BI

18 1/4 -INCH WHEEL DIAMETER  
OUTLET AREA (SQ. FT.) 1.898

TIP SPEED (FPM) = 4.78 x RPM  
MAX. BHP = .580 x (RPM/1000)<sup>3</sup>

VOLUME CFM	O.V. FPM	SP, in. WG													
		1/4" RPM BHP	3/8" RPM BHP	1/2" RPM BHP	5/8" RPM BHP	3/4" RPM BHP	1.0" RPM BHP	1-1/4" RPM BHP	1-1/2" RPM BHP	1-3/4" RPM BHP	2.0" RPM BHP	2-1/2" RPM BHP	3.0" RPM BHP	3-1/2" RPM BHP	
1600	843	594 0.12	651 0.16	704 0.20	760 0.25	813 0.30	913 0.40	1000 0.51	1088 0.62	1169 0.74	1245 0.87	1387 1.14	1517 1.46	1637 1.80	
1800	948	641 0.15	692 0.19	742 0.24	789 0.28	840 0.34	935 0.45	1022 0.57	1100 0.68	1178 0.80	1254 0.94	1393 1.21	1520 1.51	1639 1.86	
2000	1054	690 0.19	737 0.23	783 0.28	827 0.33	869 0.38	959 0.50	1044 0.63	1123 0.75	1194 0.88	1263 1.01	1401 1.30	1527 1.61	1643 1.93	
2200	1159	739 0.23	784 0.28	826 0.33	868 0.38	907 0.43	987 0.55	1067 0.68	1144 0.83	1217 0.97	1284 1.11	1410 1.40	1535 1.72	1651 2.05	
2400	1264	789 0.28	833 0.33	872 0.38	911 0.44	948 0.49	1019 0.61	1095 0.75	1167 0.90	1238 1.05	1307 1.21	1428 1.51	1544 1.83	1659 2.18	
2600	1370	839 0.33	881 0.39	920 0.45	956 0.50	991 0.56	1060 0.69	1125 0.82	1195 0.97	1262 1.13	1327 1.30	1452 1.63	1561 1.96	1668 2.31	
2800	1475	890 0.39	931 0.46	969 0.52	1003 0.58	1036 0.64	1101 0.77	1163 0.91	1224 1.05	1290 1.22	1352 1.39	1474 1.75	1585 2.11	1685 2.47	
3000	1581	942 0.46	982 0.53	1017 0.60	1051 0.67	1082 0.73	1144 0.87	1204 1.01	1261 1.15	1318 1.31	1380 1.49	1494 1.86	1608 2.27	1709 2.64	
3200	1686	994 0.54	1032 0.61	1067 0.69	1100 0.76	1130 0.83	1189 0.97	1246 1.12	1301 1.27	1354 1.43	1408 1.60	1521 1.99	1626 2.39	1732 2.82	
3400	1791	1046 0.66	1083 0.71	1117 0.78	1149 0.86	1179 0.94	1235 1.09	1289 1.24	1342 1.40	1394 1.56	1433 1.73	1549 2.12	1652 2.54	1751 2.97	
3600	1897	1099 0.72	1134 0.81	1167 0.89	1198 0.97	1228 1.05	1282 1.21	1334 1.37	1385 1.54	1435 1.71	1483 1.88	1578 2.25	1679 2.69	1774 3.13	
3800	2002	1152 0.83	1186 0.92	1218 1.01	1248 1.09	1277 1.18	1331 1.35	1380 1.52	1429 1.69	1477 1.86	1524 2.04	1613 2.41	1708 2.85	1802 3.31	
4200	2213	1259 1.07	1291 1.17	1321 1.27	1350 1.37	1377 1.46	1428 1.66	1476 1.85	1521 2.03	1565 2.22	1608 2.41	1694 2.81	1774 3.21	1858 3.68	
4600	2424	1368 1.37	1397 1.47	1425 1.58	1452 1.69	1478 1.80	1527 2.01	1573 2.22	1617 2.43	1658 2.63	1698 2.83	1777 3.25	1856 3.69	1929 4.13	
5000	2634	1476 1.71	1504 1.83	1530 1.95	1556 2.06	1581 2.18	1628 2.41	1672 2.54	1714 2.87	1754 3.10	1792 3.31	1866 3.76	1939 4.22	2011 4.69	
5400	2845	1586 2.11	1612 2.24	1637 2.37	1661 2.49	1684 2.62	1729 2.88	1772 3.12	1812 3.37	1851 3.62	1888 3.86	1958 4.34	2027 4.82	2094 5.31	
5800	3056	1696 2.58	1720 2.71	1744 2.85	1767 2.98	1789 3.12	1832 3.40	1873 3.67	1912 3.93	1949 4.20	1986 4.48	2054 4.98	2117 5.49	2182 6.01	
6200	3267	1806 3.11	1829 3.25	1851 3.40	1873 3.54	1894 3.69	1936 3.98	1975 4.28	2013 4.56	2049 4.84	2084 5.13	2151 5.70	2213 6.24	2272 6.79	

Performance certified is for Installation Type B - Free Inlet, Ducted Outlet.  
Power rating (BHP) does not include transmission losses.  
Performance ratings do not include the effects of appurtenances (accessories).

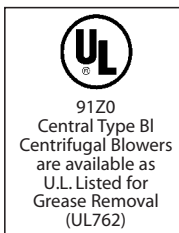

# 20-BI

20-INCH WHEEL DIAMETER  
OUTLET AREA (SQ. FT.) 2.280

TIP SPEED (FPM) = 5.24 x RPM  
MAX. BHP = .910 x (RPM/1000)<sup>3</sup>

VOLUME CFM	O.V. FPM	SP, in. WG																											
		1/4"		3/8"		1/2"		5/8"		3/4"		1.0"		1-1/4"		1-1/2"		1-3/4"		2.0"		2-1/2"		3.0"		3-1/2"			
		RPM	BHP	RPM	BHP	RPM	BHP	RPM	BHP	RPM	BHP	RPM	BHP	RPM	BHP	RPM	BHP	RPM	BHP	RPM	BHP	RPM	BHP	RPM	BHP	RPM	BHP	RPM	BHP
1900	833	517	0.13	582	0.18	637	0.23	689	0.28	736	0.34	825	0.45	904	0.57	983	0.73												
2200	965	541	0.16	621	0.23	672	0.31	720	0.34	766	0.40	850	0.52	928	0.65	1000	0.79	1066	0.93										
2500	1096	586	0.20	646	0.27	711	0.34	757	0.40	799	0.46	881	0.61	950	0.74	1024	0.89	1090	1.04	1152	1.20								
2800	1228	634	0.25	677	0.31	740	0.41	796	0.47	837	0.54	912	0.68	985	0.84	1052	1.00	1114	1.16	1176	1.33	1288	1.68	1390	2.05				
3100	1360	683	0.31	724	0.38	763	0.45	824	0.54	876	0.63	949	0.78	1017	0.95	1083	1.12	1144	1.29	1201	1.47	1312	1.84	1413	2.23	1507	2.64		
3400	1491	735	0.39	772	0.46	807	0.53	848	0.61	903	0.71	988	0.90	1053	1.07	1114	1.24	1175	1.43	1231	1.62	1336	2.01	1437	2.42	1531	2.85		
3700	1623	789	0.47	821	0.55	855	0.63	887	0.71	927	0.80	1026	1.02	1091	1.21	1150	1.39	1206	1.58	1260	1.79	1366	2.20	1462	2.63	1555	3.08		
4000	1754	843	0.57	871	0.65	903	0.73	934	0.82	963	0.90	1049	1.13	1131	1.36	1189	1.56	1243	1.76	1294	1.96	1397	2.40	1491	2.85	1579	3.32		
4300	1886	897	0.67	924	0.76	952	0.85	982	0.95	1010	1.04	1073	1.24	1159	1.50	1228	1.74	1281	1.95	1332	2.16	1429	2.61	1522	3.09	1609	3.58		
4600	2018	952	0.80	978	0.89	1002	0.99	1031	1.09	1058	1.18	1109	1.38	1183	1.64	1261	1.91	1320	2.15	1370	2.38	1463	2.85	1554	3.34	1639	3.84		
4900	2149	1008	0.94	1032	1.04	1056	1.14	1080	1.25	1106	1.35	1156	1.56	1207	1.78	1285	2.07	1357	2.37	1409	2.62	1501	3.11	1585	3.60	1671	4.14		
5200	2281	1064	1.10	1087	1.20	1109	1.31	1131	1.42	1155	1.53	1204	1.75	1249	1.97	1309	2.24	1380	2.55	1448	2.87	1539	3.38	1623	3.82	1702	4.44		
5800	2544	1176	1.46	1197	1.58	1218	1.70	1238	1.82	1257	1.94	1301	2.19	1344	2.43	1385	2.68	1428	2.95	1495	3.30	1618	4.00	1700	4.57	1776	5.14		
6400	2807	1289	1.91	1309	2.04	1328	2.17	1346	2.30	1364	2.43	1400	2.71	1440	2.97	1479	3.24	1517	3.52	1553	3.80	1665	4.53	1776	5.30	1853	5.94		
7000	3070	1403	2.44	1421	2.58	1438	2.72	1456	2.87	1473	3.01	1505	3.30	1539	3.60	1576	3.89	1612	4.19	1646	4.49	1712	5.10	1823	5.94	1925	6.79		
7600	3333	1517	3.07	1534	3.22	1550	3.37	1567	3.53	1582	3.68	1613	4.00	1643	4.32	1674	4.64	1709	4.96	1742	5.24	1836	6.23	1870	6.62	1972	7.54		

# 22-BI

22.25 -INCH WHEEL DIAMETER  
OUTLET AREA (SQ. FT.) 2.821

TIP SPEED (FPM) = 5.83 x RPM  
MAX. BHP = 1.562 x (RPM/1000)<sup>3</sup>

VOLUME CFM	O.V. FPM	SP, in. WG																											
		1/4"		3/8"		1/2"		5/8"		3/4"		1.0"		1-1/4"		1-1/2"		1-3/4"		2.0"		2-1/2"		3.0"		3-1/2"			
		RPM	BHP	RPM	BHP	RPM	BHP	RPM	BHP	RPM	BHP	RPM	BHP	RPM	BHP	RPM	BHP	RPM	BHP	RPM	BHP	RPM	BHP	RPM	BHP	RPM	BHP	RPM	BHP
2200	780	466	0.16	514	0.21	564	0.27	611	0.34	658	0.42	737	0.55	815	0.71	888	0.87	955	1.05	1018	1.23	1136	1.66	1243	2.12	1341	2.61		
2500	886	503	0.20	547	0.26	589	0.32	633	0.39	675	0.47	757	0.63	827	0.79	895	0.95	963	1.14	1024	1.33	1138	1.73	1245	2.20	1343	2.71		
2800	993	542	0.25	583	0.31	622	0.39	659	0.44	698	0.52	774	0.70	846	0.88	910	1.06	975	1.24	1031	1.44	1145	1.86	1248	2.30	1346	2.81		
3100	1099	583	0.30	621	0.37	657	0.44	692	0.52	725	0.59	796	0.77	863	0.96	929	1.17	988	1.36	1042	1.56	1152	2.00	1255	2.46	1350	2.95		
3400	1205	624	0.37	661	0.45	694	0.52	727	0.60	759	0.68	820	0.85	885	1.06	945	1.27	1007	1.50	1061	1.71	1162	2.14	1262	2.63	1357	3.14		
3700	1312	665	0.44	701	0.53	733	0.61	760	0.69	793	0.78	851	0.96	908	1.16	968	1.38	1023	1.61	1080	1.86	1180	2.32	1272	2.80	1364	3.33		
4000	1418	707	0.53	741	0.62	773	0.71	801	0.80	830	0.89	885	1.08	936	1.27	991	1.50	1045	1.74	1097	1.99	1200	2.52	1289	3.02	1374	3.53		
4300	1524	750	0.63	783	0.73	813	0.83	841	0.92	867	1.02	919	1.21	970	1.42	1017	1.63	1069	1.88	1119	2.14	1216	2.68	1309	3.24	1391	3.78		
4600	1631	793	0.74	824	0.84	854	0.95	881	1.05	906	1.16	956	1.36	1004	1.57	1050	1.80	1095	2.03	1143	2.30	1236	2.86	1326	3.45	1411	4.05		
4900	1737	836	0.86	867	0.98	895	1.09	921	1.20	946	1.31	993	1.53	1039	1.75	1084	1.98	1122	2.22	1169	2.47	1259	3.05	1374	3.66	1429	4.30		
5200	1843	879	1.00	909	1.12	936	1.24	962	1.36	987	1.48	1032	1.71	1075	1.94	1118	2.1	1160	2.43	1200	2.68	1282	3.25	1366	3.88	1444	4.52		
5800	2056	967	1.32	995	1.45	1021	1.89	1045	1.72	1068	1.85	1112	2.12	1152	2.37	1191	2.63	1229	2.90	1267	3.17	1340	3.73	1413	4.35	1489	5.06		
6400	2269	1056	1.70	1082	1.85	1106	2.00	1129	2.16	1151	2.30	1193	2.59	1232	2.89	1268	3.17	1303	3.45	1339	3.74	1407	4.34	1473	4.95	1538	5.62		
7000	2481	1146	2.16	1170	2.33	1192	2.49	1214	2.66	1235	2.82	1275	3.14	1312	3.46	1348	3.78	1381	4.098	1413	4.40	1478	5.03	1540	5.69	1601	6.36		
7600	2694	1236	2.70	1258	2.88	1280	3.06	1300	3.24	1320	3.42	1358	3.77	1394	4.12	1429	4.47	1461	4.82	1492	5.15	1551	5.82	1610	6.51	1668	7.23		
8200	2907	1327	3.33	1348	3.53	1368	3.72	1387	3.91	1406	4.10	1443	4.50	1477	4.87	1510	5.24	1542	5.62	1572	5.99	1629	6.71	1684	7.44	1738	8.19		
8800	3119	1418	4.06	1438	4.26	1457	4.47	1475	4.68	1493	4.88	1528	5.30	1461	5.71	1593	6.11	1623	6.52	1653	6.92	1708	7.71	1760	8.48	1812	9.27		
9400	3332	1510	4.89	1528	5.10	1546	5.32	1564	5.54	1581	5.76	1614	6.21	1646	6.66	1677	7.09	1706	7.52	1734	7.95	1789	8.82	1839	9.64	1887	10.1		

Performance certified is for Installation Type B - Free Inlet, Ducted Outlet.  
Power rating (BHP) does not include transmission losses.  
Performance ratings do not include the effects of appurtenances (accessories).

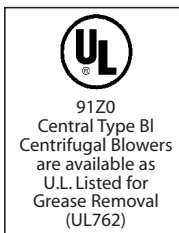

# 24-BI

24.50-INCH WHEEL DIAMETER  
OUTLET AREA (SQ. FT.) 3.490

TIP SPEED (FPM) = 6.41 x RPM  
MAX. BHP = 2.420 x (RPM/1000)<sup>3</sup>

VOLUME CFM	O.V. FPM	SP, in. WG																									
		1/4"		3/8"		1/2"		5/8"		3/4"		1.0"		1-1/4"		1-1/2"		1-3/4"		2.0"		2-1/2"		3.0"		3-1/2"	
		RPM	BHP	RPM	BHP	RPM	BHP	RPM	BHP	RPM	BHP	RPM	BHP	RPM	BHP	RPM	BHP	RPM	BHP	RPM	BHP	RPM	BHP	RPM	BHP	RPM	BHP
2800	802	428	0.18	476	0.25	522	0.32	565	0.40	606	0.448	680	0.65	748	0.83	811	1.02	872	1.22	929	1.43	1034	1.86	1130	2.30	1217	2.77
3200	917	457	0.23	504	0.31	547	0.38	587	0.46	626	0.55	698	0.74	763	0.93	824	1.13	881	1.34	936	1.56	1040	2.02	1135	2.51	1222	3.01
3600	1032	491	0.28	534	0.37	575	0.45	613	0.54	649	0.63	718	0.83	781	1.03	840	1.25	895	1.47	948	1.70	1047	2.18	1141	2.71	1227	3.25
4000	1146	525	0.35	567	0.44	605	0.53	641	0.63	676	0.73	740	0.93	801	1.15	859	1.38	912	1.62	963	1.86	1059	2.37	1148	2.90	1234	3.47
4400	1261	561	0.43	600	0.52	637	0.62	670	0.72	703	0.83	766	1.05	824	1.27	879	1.51	931	1.77	981	2.03	1074	2.56	1161	3.12	1242	3.70
4800	1375	598	0.51	634	0.62	670	0.72	702	0.83	733	0.94	792	1.18	848	1.42	901	1.67	952	1.93	1001	2.20	1091	2.77	1176	3.36	1256	3.97
5200	1490	636	0.62	670	0.72	703	0.84	735	0.95	765	1.07	821	1.32	875	1.58	925	1.84	974	2.11	1021	2.39	1110	2.98	1193	3.60	1270	4.24
5600	1605	674	0.73	707	0.85	738	0.97	768	1.09	797	1.22	851	1.48	902	1.75	952	2.03	998	2.30	1044	2.59	1130	3.21	1212	3.86	1288	4.53
6000	1719	712	0.86	744	0.99	774	1.11	802	1.24	830	1.38	883	1.65	931	1.93	979	2.23	1025	2.53	1068	2.82	1152	3.46	1231	4.13	1306	4.83
7000	2006	811	1.27	839	1.41	866	1.56	892	1.70	916	1.85	964	2.16	1010	2.48	1053	2.80	1095	3.14	1136	3.48	1213	4.18	1286	4.88	1358	5.64
8000	2292	912	1.79	936	1.95	960	2.12	984	2.29	1007	2.45	1051	2.79	1093	3.14	1134	3.51	1172	3.87	1209	4.25	1282	5.02	1351	5.82	1417	6.60
9000	2579	1014	2.44	1036	2.63	1057	2.82	1079	3.01	1101	3.19	1141	3.57	1179	3.95	1217	4.34	1254	4.75	1290	5.16	1356	5.99	1421	6.86	1484	7.76
10000	2865	1117	3.25	1137	3.46	1157	3.67	1176	3.88	1196	4.09	1234	4.50	1270	4.92	1305	5.35	1338	5.77	1372	6.22	1437	7.13	1497	8.06	1555	9.01
11000	3152	1221	4.23	1239	4.46	1258	4.69	1275	4.92	1295	5.16	1328	5.61	1363	6.07	1396	6.53	1427	6.99	1458	7.46	1519	8.44	1578	9.44	1633	10.5
12000	3438	1325	5.40	1342	5.65	1359	5.90	1376	6.15	1392	6.41	1424	6.91	1457	7.41	1488	7.90	1518	8.41	1547	8.91	1603	9.93	1660	11.0	1714	12.1

# 27-BI

27.00 -INCH WHEEL DIAMETER  
OUTLET AREA (SQ. FT.) 4.260

TIP SPEED (FPM) = 7.07 x RPM  
MAX. BHP = 3.982 x (RPM/1000)<sup>3</sup>

VOLUME CFM	O.V. FPM	SP, in. WG																									
		1/4"		3/8"		1/2"		5/8"		3/4"		1.0"		1-1/4"		1-1/2"		1-3/4"		2.0"		2-1/2"		3.0"		3-1/2"	
		RPM	BHP	RPM	BHP	RPM	BHP	RPM	BHP	RPM	BHP	RPM	BHP	RPM	BHP	RPM	BHP	RPM	BHP	RPM	BHP	RPM	BHP	RPM	BHP	RPM	BHP
3400	798	390	0.21	430	0.30	467	0.34	502	0.45	538	0.55	604	0.79	669	0.99	730	1.22	785	1.45	838	1.69	930	2.20	1017	2.78	1095	3.33
3800	892	414	0.27	452	0.36	488	0.42	520	0.52	552	0.63	615	0.87	680	1.10	738	1.32	790	1.58	840	1.82	935	2.33	1020	2.94	1098	3.55
4200	985	442	0.34	482	0.44	512	0.52	545	0.60	572	0.73	630	0.95	691	1.20	745	1.43	795	1.72	845	1.95	940	2.50	1024	3.14	1100	3.78
4600	1080	470	0.40	509	0.50	538	0.61	568	0.72	593	0.83	648	1.05	706	1.30	758	1.56	802	1.85	855	2.10	942	2.66	1029	3.33	1105	4.00
5000	1174	504	0.44	540	0.58	566	0.70	592	0.83	622	0.96	667	1.17	722	1.42	771	1.70	812	2.00	866	2.28	950	2.84	1030	3.56	1110	4.22
5400	1268	530	0.54	568	0.67	593	0.82	617	0.95	648	1.08	688	1.30	740	1.56	786	1.84	827	2.16	880	2.30	958	3.04	1038	3.75	1115	4.49
5800	1362	560	0.65	597	0.80	620	0.94	645	1.09	673	1.22	710	1.42	760	1.56	804	2.00	842	2.31	892	2.60	967	3.23	1048	3.96	1122	4.70
6200	1455	592	0.77	626	0.90	648	1.08	674	1.22	702	1.37	738	1.60	780	1.88	822	2.18	863	2.50	910	2.81	980	3.42	1059	4.20	1132	4.93
6600	1549	623	0.92	655	1.05	675	1.22	702	1.38	728	1.52	777	1.76	803	2.06	843	2.38	886	2.69	928	3.03	996	3.68	1082	4.47	1141	5.23
7000	1643	658	1.07	687	1.20	704	1.36	732	1.52	755	1.68	793	1.93	831	2.25	868	2.59	908	2.90	949	3.24	1014	3.95	1088	4.72	1152	5.51
8000	1878	738	1.50	760	1.62	779	1.78	803	1.92	822	2.14	860	2.45	900	2.82	936	3.19	969	3.55	1006	3.88	1069	4.68	1130	5.48	1194	6.36
9000	2113	816	2.00	834	2.14	854	2.31	876	2.45	890	2.73	929	3.12	970	3.41	1002	3.96	1032	4.35	1065	4.67	1127	5.60	1182	6.42	1240	7.28
10000	2347	894	2.63	910	2.80	929	2.97	948	3.16	967	3.48	1000	3.90	1039	4.33	1070	4.88	1098	5.30	1129	5.95	1189	6.83	1240	7.70	1293	8.40
11000	2582	972	3.41	988	3.60	1005	3.80	1022	3.98	1040	4.30	1074	4.81	1109	5.24	1138	5.85	1166	6.35	1193	6.80	1252	7.87	1302	8.85	1350	9.73
12000	2817	1052	4.40	1067	4.52	1082	4.70	1102	4.93	1121	5.28	1150	5.85	1178	6.30	1213	6.88	1238	7.50	1264	8.00	1320	9.05	1365	10.3	1412	11.2
13000	3052	1132	5.45	1145	5.60	1160	5.74	1180	6.00	1198	6.42	1229	7.02	1253	7.52	1282	8.15	1305	8.75	1332	9.25	1390	10.5	1430	11.8	1477	12.8
14000	3286	1210	6.55	1222	6.73	1238	6.95	1256	7.29	1275	7.66	1307	8.35	1330	8.90	1355	9.58	1382	10.3	1405	10.8	1460	12.1	1495	13.5	1540	14.6

Performance certified is for Installation Type B - Free Inlet, Ducted Outlet.  
Power rating (BHP) does not include transmission losses.  
Performance ratings do not include the effects of appurtenances (accessories).

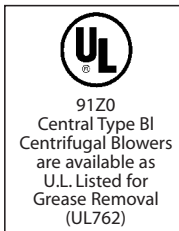

# 30-BI

30.00-INCH WHEEL DIAMETER  
OUTLET AREA (SQ. FT.) 5.260

TIP SPEED (FPM) = 7.85 x RPM  
MAX. BHP = 6.743 x (RPM/1000)<sup>3</sup>

VOLUME CFM	O.V. FPM	SP, in. WG																									
		1/4"		3/8"		1/2"		5/8"		3/4"		1.0"		1-1/4"		1-1/2"		1-3/4"		2.0"		2-1/2"		3.0"		3-1/2"	
		RPM	BHP	RPM	BHP	RPM	BHP	RPM	BHP	RPM	BHP	RPM	BHP	RPM	BHP	RPM	BHP	RPM	BHP	RPM	BHP	RPM	BHP	RPM	BHP	RPM	BHP
4000	760	351	0.25	387	0.35	419	0.43	452	0.53	484	0.64	544	0.91	602	1.16	657	1.47	707	1.73	754	2.00	837	2.64	915	3.33	986	4.00
4500	855	365	0.35	401	0.43	432	0.49	463	0.62	493	0.74	550	1.02	607	1.30	689	1.48	710	1.89	756	2.17	839	2.81	918	3.53	989	4.66
5000	950	390	0.37	424	0.46	450	0.58	482	0.69	508	0.84	562	1.12	620	1.42	666	1.73	713	2.04	759	2.35	844	3.00	920	3.77	990	4.54
5500	1045	416	0.43	450	0.57	477	0.70	504	0.84	527	0.99	576	1.23	630	1.57	678	1.86	720	2.22	766	2.52	847	3.21	924	4.01	993	4.81
6000	1140	443	0.49	476	0.67	501	0.81	526	0.98	551	1.11	594	1.38	644	1.72	689	2.02	729	2.41	774	2.72	851	3.43	927	4.28	997	5.11
6500	1239	468	0.62	502	0.78	526	0.98	547	1.12	576	1.28	612	1.53	661	1.85	702	2.22	731	2.59	787	2.95	857	3.65	932	4.54	1001	5.42
7000	1331	495	0.74	529	0.90	551	1.11	572	1.28	599	1.46	632	1.72	679	2.16	717	2.39	754	2.79	800	3.14	867	3.90	940	4.81	1008	5.68
8000	1521	553	1.06	581	1.23	600	1.44	624	1.62	648	1.81	682	2.10	7717	2.47	752	2.84	792	3.25	830	3.64	892	4.44	961	5.42	1024	6.35
9000	1711	612	1.47	636	1.60	652	1.80	677	2.01	697	2.22	732	2.54	765	2.96	797	3.52	831	3.78	868	4.20	926	5.12	990	6.07	1049	7.22
10000	1901	670	1.90	689	2.05	707	2.25	729	2.41	745	2.69	779	3.09	817	3.54	848	4.01	877	4.46	909	4.88	965	5.86	1020	6.77	1078	7.97
11000	2091	728	2.42	746	2.59	763	2.79	783	2.98	797	3.31	830	3.77	867	4.26	896	4.81	923	5.28	953	5.68	1009	6.79	1059	7.80	1112	8.89
12000	2281	785	3.04	801	3.21	817	3.42	835	3.64	851	4.05	883	4.57	918	5.06	945	5.70	971	6.21	1001	6.60	1055	7.72	1102	8.97	1150	9.97
13000	2471	842	3.73	857	3.95	873	4.20	887	4.42	904	4.79	935	5.37	968	5.91	995	6.64	1019	7.22	1046	7.72	1099	8.91	1144	10.2	1191	11.2
14000	2662	900	4.62	914	4.81	927	5.04	943	5.30	961	5.70	990	6.36	1017	6.89	1047	7.668	1071	8.31	1095	8.89	1146	10.1	1119	11.4	1236	12.6
15000	2852	958	5.59	971	5.74	984	5.95	1003	6.26	1019	6.69	1028	7.41	1069	7.99	1102	8.70	1125	9.44	1147	10.1	1199	11.4	1238	12.9	1278	14.0
16000	3042	1015	6.64	1028	6.84	1040	7.04	1060	7.35	1075	7.88	1103	8.60	1125	9.20	1151	9.97	1175	10.7	1197	11.4	1249	12.9	1285	14.4	1328	15.7
17000	3232	1073	7.78	1085	7.96	1098	8.21	1115	8.59	1131	9.10	1159	9.91	1181	10.5	1204	11.3	1227	12.2	1249	12.9	1301	14.4	1334	16.0	1373	17.4
18000	3422	1130	9.05	1143	9.31	1157	9.63	1175	10.0	1191	10.5	1206	11.4	1224	12.1	1260	12.9	1283	13.7	1307	14.5	1352	16.2	1384	17.9	1422	19.3

# 36-BI

36.50-INCH WHEEL DIAMETER  
OUTLET AREA (SQ. FT.) 7.785

TIP SPEED (FPM) = 9.56 x RPM  
MAX. BHP = 17.977 x (RPM/1000)<sup>3</sup>

VOLUME CFM	O.V. FPM	SP, in. WG																									
		1/4"		3/8"		1/2"		5/8"		3/4"		1.0"		1-1/4"		1-1/2"		1-3/4"		2.0"		2-1/2"		3.0"		3-1/2"	
		RPM	BHP	RPM	BHP	RPM	BHP	RPM	BHP	RPM	BHP	RPM	BHP	RPM	BHP	RPM	BHP	RPM	BHP	RPM	BHP	RPM	BHP	RPM	BHP	RPM	BHP
6000	770	285	0.37	314	0.49	324	0.60	368	0.79	395	0.95	445	1.35	492	1.72	540	2.19	580	2.58	618	2.98	689	3.93	752	4.95	809	5.96
7000	899	309	0.49	337	0.68	362	0.79	385	0.95	411	1.17	456	1.57	503	2.01	545	2.25	584	2.91	621	3.34	685	4.29	754	5.39	812	6.43
8000	1027	337	0.60	365	0.82	389	0.99	411	1.19	429	1.43	471	1.81	516	2.25	556	2.70	591	3.23	629	3.66	695	4.70	759	5.87	815	7.05
9000	1156	369	0.77	396	1.01	416	1.10	436	1.48	457	1.68	491	2.08	533	2.56	569	3.07	601	3.60	638	4.08	701	5.10	763	6.40	821	7.68
10000	1284	396	1.02	423	1.28	442	1.55	460	1.79	482	2.03	510	2.41	551	2.89	583	3.42	614	4.00	652	4.48	709	5.61	769	6.93	826	8.26
11000	1412	428	1.30	454	1.59	471	1.86	490	2.14	510	2.38	538	2.78	571	3.31	602	3.84	632	4.42	668	4.99	720	6.09	778	7.49	834	8.83
12000	1541	462	1.64	484	1.88	500	2.19	519	2.47	539	2.74	566	3.18	594	3.73	623	4.29	653	4.83	684	5.48	735	6.67	791	8.08	844	9.50
13000	1669	493	2.05	515	2.25	527	2.58	549	2.89	564	3.16	593	3.64	625	4.22	647	4.88	677	5.45	706	6.05	754	7.55	808	8.77	850	10.2
14000	1798	592	2.49	542	2.67	556	2.98	575	3.27	529	3.62	619	4.13	653	4.79	675	5.45	701	6.05	729	6.65	777	8.08	832	9.50	874	11.0
15000	1926	557	2.92	573	3.13	588	3.40	606	3.66	618	4.09	646	4.71	678	5.37	703	6.07	726	6.76	753	7.35	799	8.85	843	10.3	981	11.9
16000	2055	588	3.42	604	3.66	617	3.98	634	4.22	645	4.68	675	5.37	704	6.07	729	6.85	752	7.57	777	8.13	823	9.78	865	11.2	908	12.8
17000	2183	623	3.98	636	4.22	648	4.53	664	4.84	677	5.39	704	6.07	732	6.87	756	7.71	777	8.42	802	9.03	847	10.7	886	12.3	929	13.8
18000	2312	652	4.61	666	4.90	686	5.19	685	5.54	706	6.12	732	6.89	761	7.68	784	8.16	805	9.36	827	9.96	872	11.7	911	13.4	951	14.9
20000	2569	717	6.16	728	6.47	739	6.82	753	7.16	766	7.77	791	8.61	817	9.45	839	10.5	859	11.4	880	12.2	923	14.0	960	15.9	998	17.5
22000	2825	783	8.08	793	8.33	803	8.64	817	9.08	823	9.72	854	10.7	874	11.5	892	12.6	919	13.7	936	14.7	980	16.6	1012	18.8	1051	20.5
24000	3082	845	10.1	854	10.4	865	10.7	880	11.2	893	12.0	916	13.1	935	14.0	954	15.1	973	16.3	1058	17.4	1036	19.5	1064	21.8	1099	23.7
26000	3339	911	12.5	919	12.8	932	13.3	945	13.8	957	14.6	982	15.9	998	16.8	1016	18.2	1036	19.3	1054	20.4	1093	22.8	1120	25.4	1151	27.4

Performance certified is for Installation Type B - Free Inlet, Ducted Outlet.  
Power rating (BHP) does not include transmission losses.  
Performance ratings do not include the effects of appurtenances (accessories).

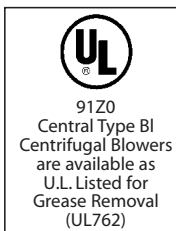

## Other Central Products

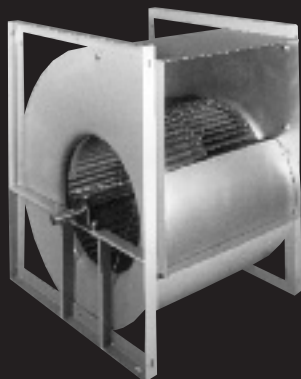

**Series FCD**  
Double Inlet Forward Curved Blowers  
Sizes: 18, 22, 26 and 30

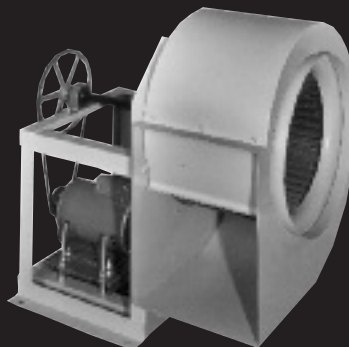

**Series FC**  
Belt Drive Blowers  
Sizes 9 thru 30"

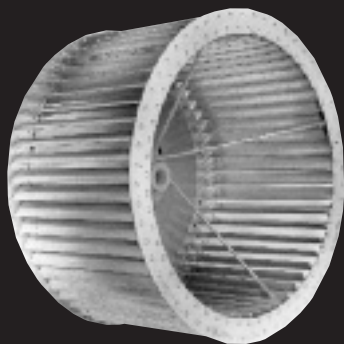

**Forward Curved and  
Backward Inclined Wheels**

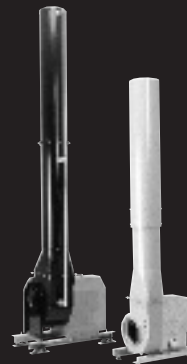

**Coated Laboratory  
Exhaust Fans**

### WARRANTY

Central Blower Co. (the Company) warrants that each blower manufactured by the Company shall be free from defects in material and workmanship under normal use and service for a period of eighteen (18) months from the date of shipment or twelve (12) months from date of original installation, "whichever occurs first." If it appears within the warranty period that the blower does not meet the warranties specified above and the purchaser notifies the Company promptly, the Company agrees to remedy any such defect, at the Company's option, either by repairing any defective parts or by furnishing at the Company's factory a repair or replacement part.

This warranty shall not apply to any equipment which has been repaired or altered in any way so as, in the Company's judgement, to affect its performance or reliability, nor which has been improperly installed or subject to misuse, negligence or accident. This warranty does not apply to electric motors, which however, carry warranty of the motor manufacturer. Warranty does not apply to drive belts.

This warranty is expressed in lieu of all other warranties expressed or implied, and of all other obligations or liabilities on the Company's part. The Company neither assumes, nor authorizes any representative or other persons to assume for it, any other liability in connection with the sale of its equipment.



**CENTRAL BLOWER CO.**

211 S. 7th Ave. • City of Industry, CA 91746 (626) 330-3182 Fax (626) 330-9406  
[www.centralblower.com](http://www.centralblower.com)