



MODEL TDB

TUBEAXIAL INLINE BELT DRIVEN DUCT FAN



MODEL FEATURES

- Rated up to 75,490 CFM in static pressure applications up to 1-1/2" w.g.
- 12 sizes ranging from 12 to 60" propeller diameters
- Motor and drives are located outside of the airstream
- Belt drives permit easy performance adjustments when needed
- Continuously welded and epoxy painted steel housing
- AMCA Air & Sound Certified
- cULus Listed

MODEL OVERVIEW

S&P's tubeaxial line offers the widest range of sizes, horsepower and performance in the industry. Models TDB are high capacity belt drive tubeaxial fans rated from 900 to 75,490 CFM, with static pressure capability up to 1-1/2". They are used to exhaust air from or supply air to such typical commercial and industrial applications as general building ventilation, enclosed garages, paint spray booths, heat and smoke ventilation systems and other applications where air is moved through a duct system against moderate static pressure.

Belt drive Models TDB are especially suited to handle fumes, vapors, steam, dust, smoke and contaminated or heated air to 200° F. They are available in larger, higher capacity sizes and offer ease in adjustment of fan performance by reducing the fan RPM with adjustable motor sheaves. (Optional on 7-1/2HP and larger).

Total access to the bearings and shaft is possible with the TDB's unique removable cover.

STANDARD CONSTRUCTION FEATURES

Drives
Sized for a minimum 150% of motor horsepower. Drives are variable pitch as standard through 5HP.

Mounting Supports
Eight (8) mounting supports are welded to each fan to allow for universal mounting.

Housing
Heavy-gauge rolled steel with continuous welded seam and epoxy coating for maximum strength.

Factory Run & Tested
For quality assurance and dependable operation.

AMCA Seal
Assures certified rating of air and sound performance.

cULus 705 Listed
For electrical reliability.

Motor
National brands with local service. Standard motors are heavy-duty open drip-proof. Other options available.

Motor Base
Adjustable steel motor base is designed for strength and ease of belt tensioning.

Integral Inlet and Outlet Flanges
With mounting holes.

Extended Lubrication Lines
Extend from bearings to the outside of the unit.

Bearings
Heavy-duty, ball bearing cast pillow blocks are designed for minimum 200,000 hours of operation, L50.

Propeller
Aluminum propellers are selected for maximum airflow and low sound.

2 year fan housing warranty, 1 year motor warranty

All specifications are subject to change without notice unless approved in submittal by Soler & Palau USA.



CONSTRUCTION/SPECIFICATION CHECKLIST

Fan Housing

- Heavy-gauge rolled steel construction.
- Integral inlet and outlet flanges with mounting holes.
- Continuous welded and epoxy coated.
- Belt and bearing tube.
- Removable bearing cover for ease of maintenance.
- Eight mounting supports welded to each fan.
- Adjustable motor base for belt tensioning.
- Extended lube lines.

Propeller

- Aluminum airfoil propeller.
- Blades are pitched for optimum efficiency.
- Statically balanced

Drives

- Sized for minimum 150% of drive horsepower.
- Single belt adjustable pitch sheaves through 5HP.
- Multiple belt fixed pitch sheaves 7-1/2HP and above.
- Adjustable tension rods for belt adjustment.
- Nonstatic oil resistant v-belts.
- Keyed, turned, ground and polished shafts.

Bearings

- Bearings are designed for minimum 200,000 hour life, L50.
- Cast iron self-aligning pillow block ball bearings.
- Bearings are sealed and prelubricated.

Motors

- One year motor warranty.
- Brands are nationally recognized and locally serviced.
- NEMA base-mounted motors are standard.
- Open drip-proof construction is standard.
- Premium-efficiency, explosion proof, totally enclosed fan cooled (TEFC) and corrosion duty motors can be specified.

Certifications

- AMCA Air and Sound Certified
- cULus 705 Listed

Entire Fan Unit

- Factory assembled and tested prior to shipment for quality assurance.



OPTIONS/ACCESSORIES

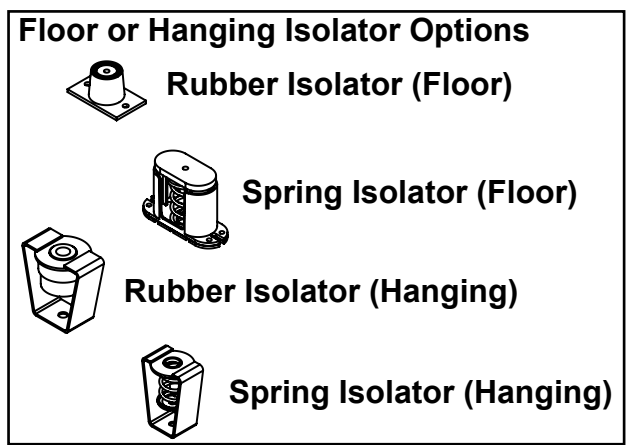
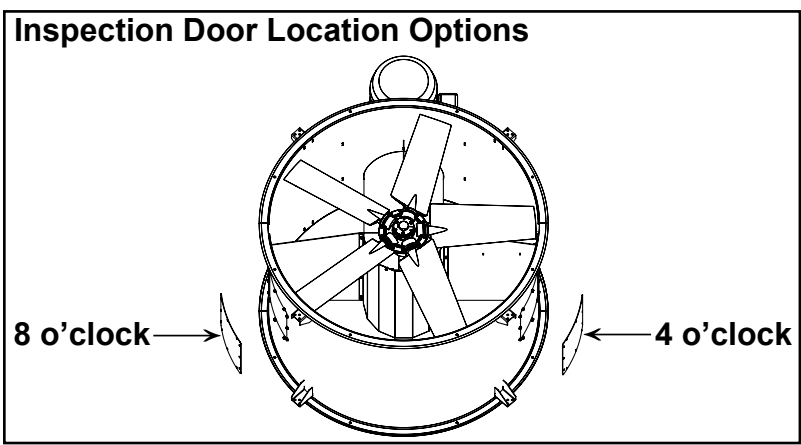
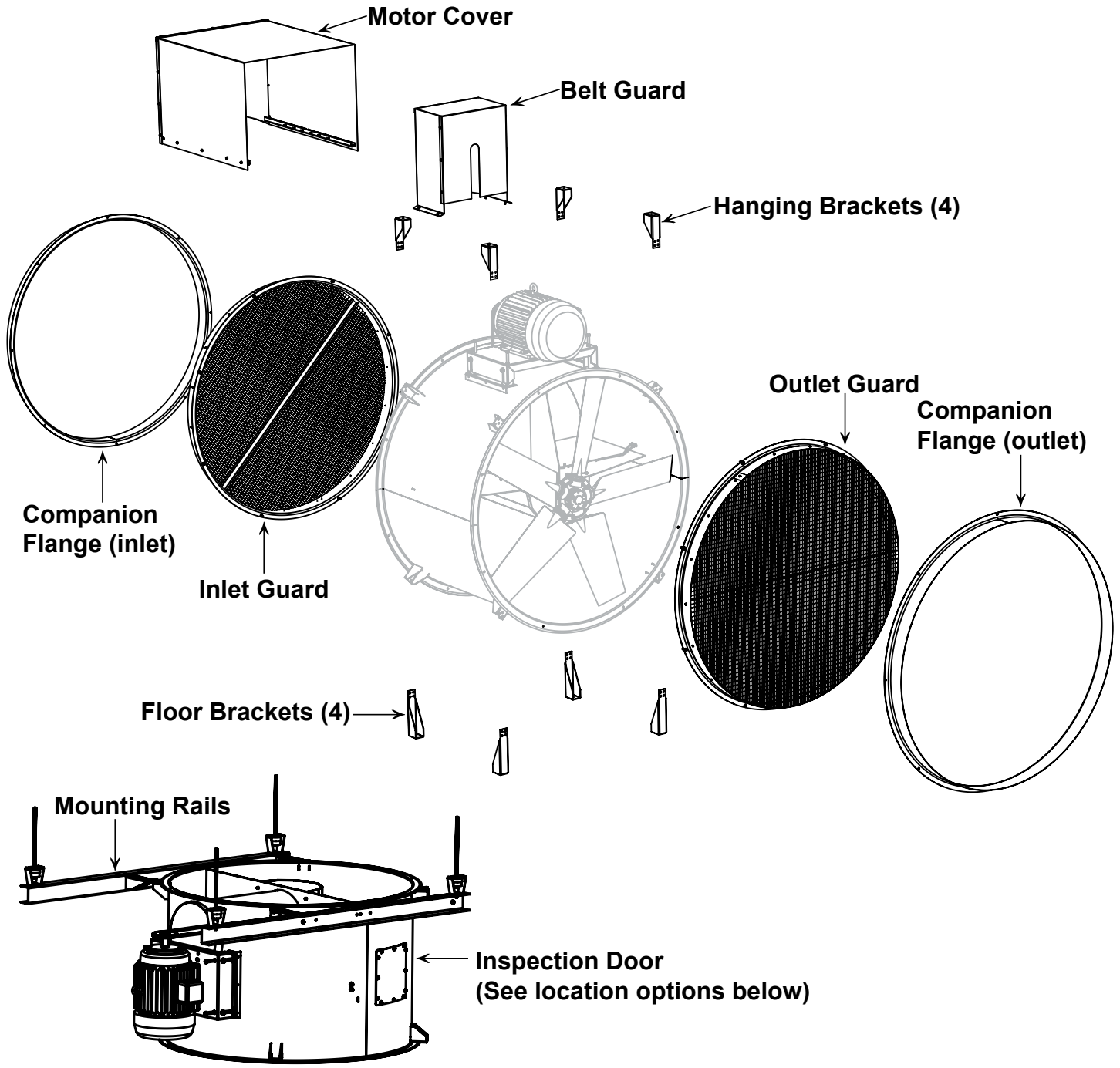



OPTIONS/ACCESSORIES

Hanging & Floor Brackets: For base or ceiling mounting. Neoprene and spring isolators are available.

Mounting Rails: Designed for vertical and horizontal mounting. Rail kits include mounting brackets.

Inlet/Outlet Guard: Prevents objects from entering the fan inlet or outlet. Includes companion flange.

Inspection Door: For inspection and blade service/cleaning. Bolted. Not available on sizes 12 and 16.

Companion Flanges: Inlet and/or outlet flanges are available for duct connection.

Belt Guard: Encloses belt and motor sheave on exterior of fan.

Motor Cover: Three sided guard that covers motor, sheave and belt. Motor may extend past cover on sizes 12, 16, and 18.

Adjustable Sheave: Can be specified for 7-1/2HP and larger units (standard through 5HP).

Shaft Seal: Protects bearings and belts when fan is handling dirty or contaminated air.

Disconnect Switch: Nonfused safety disconnect available for all motor sizes and enclosures. Specify prewired if desired. (Wiring not available on explosion proof and two speed motors).

Special Coatings (*Epoxy Coating is Standard*): For protective and decorative purposes. Available coatings include: Synthetic Resin and Heresite (air-dried phenolic). Contact your representative or the factory for more information on available coatings and colors.

MOUNTING CONFIGURATIONS

Floor Mount

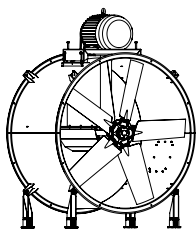

Hanging Mount

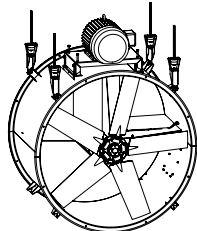

Rail Floor Mount

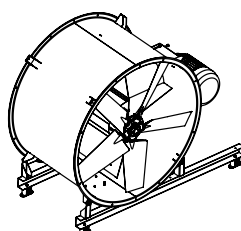

Rail Hanging Mount

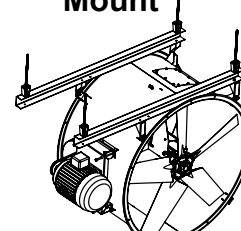

Vertical Rail Floor Mount

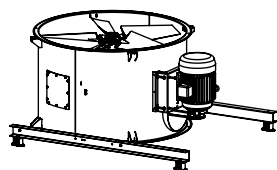

Vertical Rail Hanging Mount

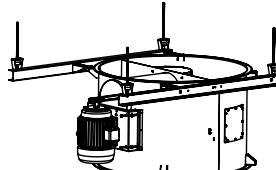



PERFORMANCE/DIMENSIONS

Size 12

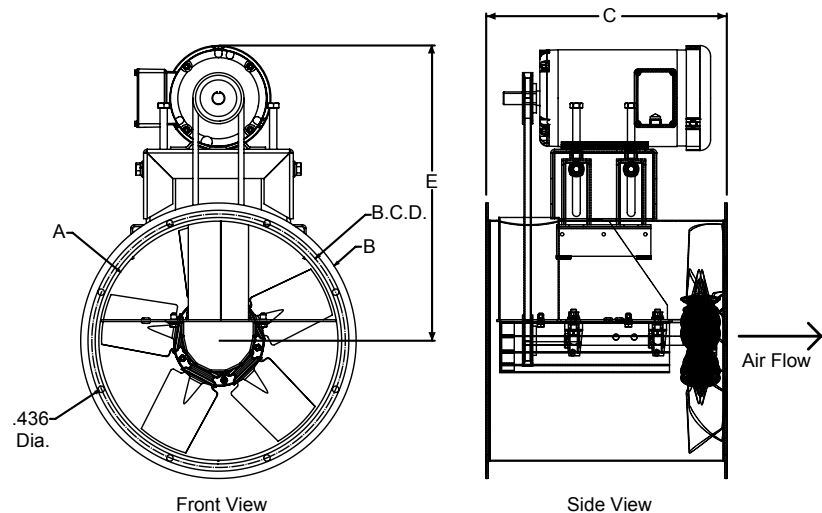

Max. Motor Frame: 145T
Shaft Size: 5/8"
Housing Gauge: 16
Approximate Weight: 90 lbs.
Flange Holes: 6
Diameter Flange Holes: 7/16"
Finish: Epoxy Coated Galvanized

A	B	C	E	B.C.D.
---	---	---	---	--------

12-3/8 14-1/2 12* 21 13-1/2

A: ID B: OD C: Length E: Max. Height

*Motor may extend past unit

HP	RPM	Static Pressure (Inches W.G.)									
		0		0.125		0.25		0.375		0.5	
		CFM	BHP	CFM	BHP	CFM	BHP	CFM	BHP	CFM	BHP
1/4	1550	1358	0.20	1189	0.20	-	-	-	-	-	-
	1600	1402	0.21	1240	0.23	914	0.22	-	-	-	-
	1650	1445	0.24	1291	0.25	1021	0.24	-	-	-	-
	1700	1489	0.26	1341	0.27	1104	0.27	-	-	-	-
1/3	1725	1511	0.27	1365	0.28	1141	0.28	-	-	-	-
	1775	1555	0.29	1414	0.31	1210	0.31	-	-	-	-
	1825	1599	0.32	1463	0.33	1274	0.34	-	-	-	-
	1875	1642	0.35	1511	0.36	1335	0.36	-	-	-	-
1/2	1925	1686	0.37	1559	0.39	1393	0.39	1001	0.38	-	-
	2000	1752	0.42	1630	0.43	1478	0.44	1211	0.43	-	-
	2075	1818	0.47	1700	0.48	1559	0.49	1341	0.49	-	-
	2150	1883	0.52	1771	0.54	1638	0.55	1450	0.55	-	-
3/4	2200	1927	0.56	1817	0.58	1690	0.59	1516	0.59	-	-
	2275	1993	0.62	1887	0.64	1767	0.65	1609	0.65	1324	0.63
	2350	2059	0.68	1956	0.70	1842	0.71	1698	0.72	1474	0.71
	2425	2124	0.75	2025	0.77	1916	0.78	1783	0.79	1593	0.78

Performance certified is for installation type A - free inlet, free outlet.
 Performance ratings do not include the effects of appurtenances (accessories).
 Power rating (BHP) does not include transmission losses.



Soler & Palau USA, Div. of Soler & Palau Ventilation Group certifies that the Models TDB shown herein are licensed to bear the AMCA Seal. The ratings shown are based on test and procedures performed in accordance with AMCA Publication 211 and AMCA Publication 311 and comply with the requirement of the AMCA Certified Ratings Program.





MODEL TDB
BELT DRIVE TUBEAXIAL DUCT FAN



Size 16

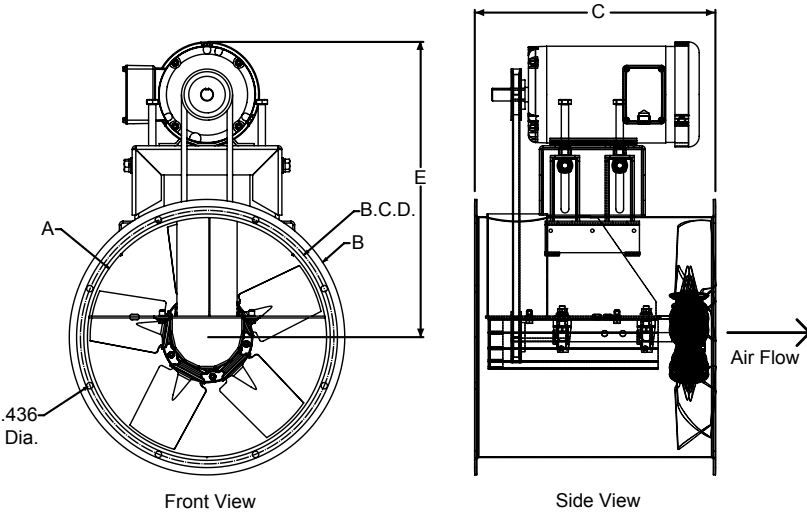

Max. Motor Frame: 145T
Shaft Size: 5/8"
Housing Gauge: 16
Approximate Weight: 110 lbs.
Flange Holes: 8
Diameter Flange Holes: 7/16"
Finish: Epoxy Coated Galvanized

A	B	C	E	B.C.D.
16-3/8	18-1/2	17*	23	17-3/8

A: ID B: OD C: Length E: Max. Height
 *Motor may extend past unit

HP	RPM	Static Pressure (Inches W.G.)																			
		0		0.125		0.25		0.375		0.5		0.625		0.75		0.875		1		1.25	
		CFM	BHP	CFM	BHP	CFM	BHP	CFM	BHP	CFM	BHP	CFM	BHP	CFM	BHP	CFM	BHP	CFM	BHP	CFM	BHP
1/4	1100	1888	0.13	1621	0.15	1270	0.16	-	-	-	-	-	-	-	-	-	-	-	-	-	-
	1175	2017	0.16	1771	0.18	1461	0.19	-	-	-	-	-	-	-	-	-	-	-	-	-	-
	1225	2103	0.18	1869	0.20	1581	0.22	1205	0.23	-	-	-	-	-	-	-	-	-	-	-	-
	1275	2189	0.21	1965	0.22	1696	0.24	1355	0.25	-	-	-	-	-	-	-	-	-	-	-	-
1/3	1300	2232	0.22	2013	0.24	1753	0.25	1427	0.27	-	-	-	-	-	-	-	-	-	-	-	-
	1350	2318	0.25	2109	0.26	1863	0.28	1563	0.30	1182	0.30	-	-	-	-	-	-	-	-	-	-
	1375	2360	0.26	2156	0.28	1917	0.30	1628	0.31	1265	0.32	-	-	-	-	-	-	-	-	-	-
	1425	2446	0.29	2250	0.31	2023	0.33	1755	0.34	1424	0.36	-	-	-	-	-	-	-	-	-	-
1/2	1475	2532	0.32	2343	0.34	2128	0.36	1876	0.38	1573	0.39	1202	0.40	-	-	-	-	-	-	-	-
	1525	2618	0.35	2436	0.37	2230	0.39	1994	0.41	1713	0.43	1374	0.44	-	-	-	-	-	-	-	-
	1575	2704	0.39	2529	0.41	2332	0.43	2108	0.45	1847	0.47	1535	0.48	1170	0.48	-	-	-	-	-	-
	1625	2790	0.43	2621	0.45	2432	0.47	2219	0.49	1975	0.51	1688	0.53	1349	0.53	-	-	-	-	-	-
3/4	1675	2875	0.47	2712	0.49	2530	0.51	2328	0.53	2099	0.56	1832	0.57	1520	0.58	1168	0.58	-	-	-	-
	1750	3004	0.53	2849	0.56	2677	0.58	2488	0.60	2277	0.63	2037	0.65	1758	0.66	1439	0.66	-	-	-	-
	1825	3133	0.61	2985	0.63	2821	0.65	2644	0.68	2448	0.70	2229	0.72	1979	0.74	1693	0.75	1374	0.75	-	-
	1875	3219	0.66	3075	0.68	2917	0.70	2746	0.73	2560	0.76	2352	0.78	2118	0.80	1852	0.81	1553	0.82	-	-
1	1925	3305	0.71	3165	0.73	3012	0.76	2848	0.79	2669	0.81	2472	0.84	2252	0.86	2004	0.87	1724	0.88	-	-
	1975	3390	0.77	3255	0.79	3106	0.82	2948	0.85	2776	0.87	2589	0.90	2381	0.92	2149	0.94	1888	0.95	1296	0.96
	2025	3476	0.83	3344	0.85	3200	0.88	3047	0.91	2882	0.93	2703	0.96	2506	0.99	2288	1.01	2043	1.02	1480	1.03
	2075	3562	0.89	3433	0.92	3294	0.94	3145	0.97	2986	1.00	2815	1.03	2627	1.05	2421	1.08	2192	1.09	1661	1.11

Performance certified is for installation type A - free inlet, free outlet.
 Performance ratings do not include the effects of appurtenances (accessories).
 Power rating (BHP) does not include transmission losses.



Soler & Palau USA, Div. of Soler & Palau Ventilation Group certifies that the Models TDB shown herein are licensed to bear the AMCA Seal. The ratings shown are based on test and procedures performed in accordance with AMCA Publication 211 and AMCA Publication 311 and comply with the requirement of the AMCA Certified Ratings Program.





Size 18

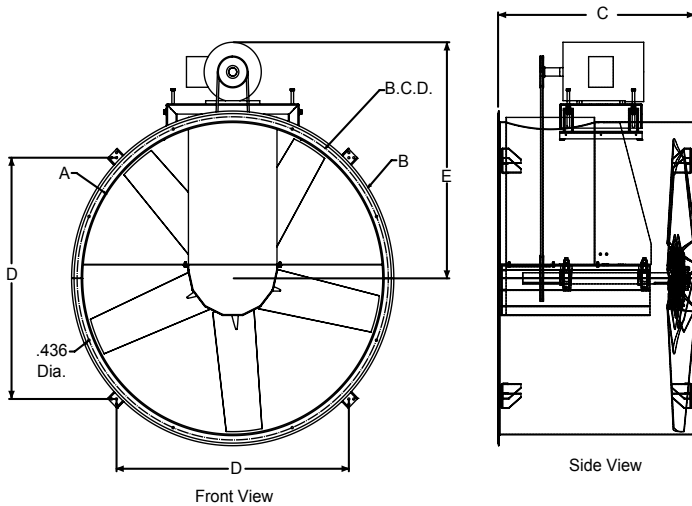

Max. Motor Frame: 182T
Shaft Size: 1"
Housing Gauge: 14
Approximate Weight: 140 lbs.
Flange Holes: 8
Diameter Flange Holes: 7/16"
Finish: Epoxy Coated Galvanized

A	B	C	D	E	B.C.D.
18-3/8	22-1/2	22*	17-15/16	25-1/2	19-3/4

A: ID B: OD C: Length E: Max. Height
 *Motor may extend past unit

HP	RPM	Static Pressure (Inches W.G.)																	
		0		0.125		0.25		0.375		0.5		0.625		0.75		0.875		1	
		CFM	BHP	CFM	BHP	CFM	BHP	CFM	BHP	CFM	BHP	CFM	BHP	CFM	BHP	CFM	BHP	CFM	BHP
1/4	1000	2509	0.15	2122	0.17	-	-	-	-	-	-	-	-	-	-	-	-	-	-
	1050	2635	0.17	2268	0.19	1809	0.21	-	-	-	-	-	-	-	-	-	-	-	-
	1100	2760	0.20	2412	0.22	1999	0.24	-	-	-	-	-	-	-	-	-	-	-	-
	1125	2823	0.21	2483	0.23	2089	0.25	-	-	-	-	-	-	-	-	-	-	-	-
1/3	1150	2886	0.23	2554	0.25	2175	0.27	-	-	-	-	-	-	-	-	-	-	-	-
	1200	3011	0.26	2694	0.28	2342	0.30	1827	0.32	-	-	-	-	-	-	-	-	-	-
	1225	3074	0.27	2763	0.30	2422	0.32	1952	0.34	-	-	-	-	-	-	-	-	-	-
1/2	1275	3199	0.31	2902	0.33	2580	0.36	2172	0.38	-	-	-	-	-	-	-	-	-	-
	1300	3262	0.33	2970	0.35	2658	0.38	2271	0.40	-	-	-	-	-	-	-	-	-	-
	1350	3387	0.37	3107	0.39	2810	0.42	2459	0.44	-	-	-	-	-	-	-	-	-	-
	1400	3513	0.41	3243	0.43	2959	0.46	2635	0.49	2184	0.50	-	-	-	-	-	-	-	-
3/4	1450	3638	0.45	3379	0.48	3106	0.51	2803	0.54	2414	0.56	-	-	-	-	-	-	-	-
	1500	3764	0.50	3513	0.53	3251	0.56	2966	0.59	2618	0.61	2059	0.62	-	-	-	-	-	-
	1550	3889	0.56	3647	0.58	3395	0.61	3124	0.64	2807	0.67	2363	0.68	-	-	-	-	-	-
	1600	4015	0.61	3781	0.64	3537	0.67	3279	0.70	2985	0.73	2606	0.75	-	-	-	-	-	-
1	1650	4140	0.67	3914	0.70	3678	0.73	3431	0.76	3156	0.79	2820	0.82	2303	0.82	-	-	-	-
	1675	4203	0.70	3980	0.73	3748	0.76	3506	0.79	3239	0.82	2919	0.85	2461	0.86	-	-	-	-
	1725	4328	0.77	4113	0.79	3887	0.82	3655	0.86	3402	0.89	3109	0.92	2726	0.94	-	-	-	-
	1775	4454	0.83	4245	0.86	4026	0.89	3801	0.93	3561	0.97	3289	1.00	2953	1.02	2437	1.02	-	-
1 1/2	1825	4579	0.91	4377	0.93	4164	0.97	3947	1.00	3717	1.04	3462	1.08	3159	1.10	2748	1.12	-	-
	1850	4642	0.94	4442	0.97	4233	1.01	4019	1.04	3794	1.08	3546	1.12	3257	1.15	2879	1.16	-	-
	1925	4830	1.06	4639	1.09	4438	1.13	4234	1.17	4021	1.20	3792	1.24	3534	1.28	3223	1.30	2787	1.31
	2000	5018	1.19	4835	1.22	4641	1.26	4446	1.30	4244	1.34	4030	1.38	3795	1.41	3525	1.45	3186	1.47
	2075	5207	1.33	5031	1.36	4844	1.40	4656	1.44	4464	1.48	4262	1.52	4044	1.56	3802	1.60	3517	1.63

Performance certified is for installation type A - free inlet, free outlet.
 Performance ratings do not include the effects of appurtenances (accessories).
 Power rating (BHP) does not include transmission losses.



Soler & Palau USA, Div. of Soler & Palau Ventilation Group certifies that the Models TDB shown herein are licensed to bear the AMCA Seal. The ratings shown are based on test and procedures performed in accordance with AMCA Publication 211 and AMCA Publication 311 and comply with the requirement of the AMCA Certified Ratings Program.





MODEL TDB
BELT DRIVE TUBEAXIAL DUCT FAN



Size 20

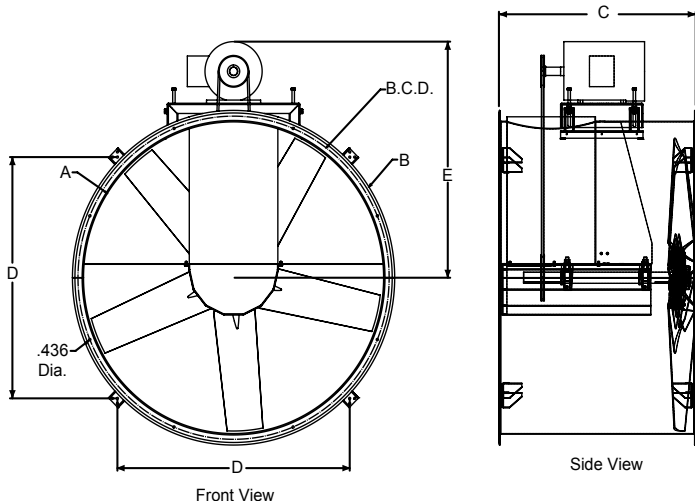

Max. Motor Frame: 184T
Shaft Size: 1"
Housing Gauge: 14
Approximate Weight: 150 lbs.
Flange Holes: 8
Diameter Flange Holes: 7/16"
Finish: Epoxy Coated Galvanized



A	B	C	D	E	B.C.D.
20-3/8	24-1/2	22	18-3/8	26-1/2	21-3/4

A: ID B: OD C: Length E: Max. Height

HP	RPM	Static Pressure (Inches W.G.)																			
		0		0.125		0.25		0.375		0.5		0.625		0.75		0.875		1		1.125	
		CFM	BHP	CFM	BHP	CFM	BHP	CFM	BHP	CFM	BHP	CFM	BHP	CFM	BHP	CFM	BHP	CFM	BHP	CFM	BHP
1/3	1050	3404	0.23	2933	0.25	-	-	-	-	-	-	-	-	-	-	-	-	-	-	-	-
	1100	3566	0.26	3119	0.29	-	-	-	-	-	-	-	-	-	-	-	-	-	-	-	-
	1125	3647	0.28	3211	0.31	2701	0.33	-	-	-	-	-	-	-	-	-	-	-	-	-	-
	1150	3728	0.30	3302	0.33	2812	0.35	-	-	-	-	-	-	-	-	-	-	-	-	-	-
1/2	1175	3809	0.32	3393	0.35	2921	0.37	-	-	-	-	-	-	-	-	-	-	-	-	-	-
	1225	3971	0.36	3573	0.39	3132	0.42	-	-	-	-	-	-	-	-	-	-	-	-	-	-
	1275	4133	0.40	3751	0.44	3336	0.47	2813	0.49	-	-	-	-	-	-	-	-	-	-	-	-
	1300	4214	0.43	3840	0.46	3436	0.49	2940	0.52	-	-	-	-	-	-	-	-	-	-	-	-
3/4	1325	4295	0.45	3929	0.49	3535	0.52	3062	0.55	-	-	-	-	-	-	-	-	-	-	-	-
	1375	4457	0.51	4104	0.54	3730	0.58	3295	0.61	2692	0.62	-	-	-	-	-	-	-	-	-	-
	1400	4539	0.53	4192	0.57	3826	0.61	3407	0.64	2848	0.66	-	-	-	-	-	-	-	-	-	-
	1450	4701	0.59	4366	0.63	4017	0.67	3624	0.70	3131	0.73	-	-	-	-	-	-	-	-	-	-
1	1525	4944	0.69	4626	0.73	4297	0.77	3938	0.81	3512	0.84	-	-	-	-	-	-	-	-	-	-
	1575	5106	0.76	4799	0.80	4482	0.84	4140	0.88	3747	0.91	3242	0.93	-	-	-	-	-	-	-	-
	1625	5268	0.84	4971	0.88	4665	0.92	4339	0.96	3971	1.00	3522	1.02	-	-	-	-	-	-	-	-
	1675	5430	0.92	5142	0.96	4846	1.00	4534	1.04	4188	1.08	3779	1.11	3238	1.13	-	-	-	-	-	-
1 1/2	1700	5511	0.96	5227	1.00	4936	1.05	4630	1.09	4294	1.13	3902	1.16	3398	1.18	-	-	-	-	-	-
	1775	5754	1.09	5483	1.13	5205	1.18	4916	1.23	4604	1.27	4253	1.31	3830	1.33	3259	1.34	-	-	-	-
	1850	5997	1.23	5737	1.28	5472	1.33	5197	1.38	4906	1.42	4585	1.46	4215	1.50	3755	1.51	-	-	-	-
	1925	6240	1.39	5990	1.44	5736	1.49	5475	1.54	5200	1.59	4903	1.63	4570	1.67	4179	1.70	3678	1.71	-	-
2	1950	6322	1.44	6075	1.49	5824	1.55	5566	1.60	5296	1.64	5006	1.69	4684	1.73	4310	1.76	3842	1.78	-	-
	2000	6484	1.56	6243	1.61	5999	1.66	5749	1.71	5488	1.76	5211	1.81	4907	1.85	4561	1.89	4146	1.91	-	-
	2050	6646	1.68	6411	1.73	6173	1.78	5930	1.84	5678	1.89	5412	1.94	5123	1.98	4801	2.02	4425	2.05	3956	2.06
	2075	6727	1.74	6495	1.79	6260	1.85	6020	1.90	5772	1.95	5511	2.00	5229	2.05	4917	2.09	4558	2.12	4118	2.14

Performance certified is for installation type A - free inlet, free outlet.
 Performance ratings do not include the effects of appurtenances (accessories).
 Power rating (BHP) does not include transmission losses.



Soler & Palau USA, Div. of Soler & Palau Ventilation Group certifies that the Models TDB shown herein are licensed to bear the AMCA Seal. The ratings shown are based on test and procedures performed in accordance with AMCA Publication 211 and AMCA Publication 311 and comply with the requirement of the AMCA Certified Ratings Program.





Size 24

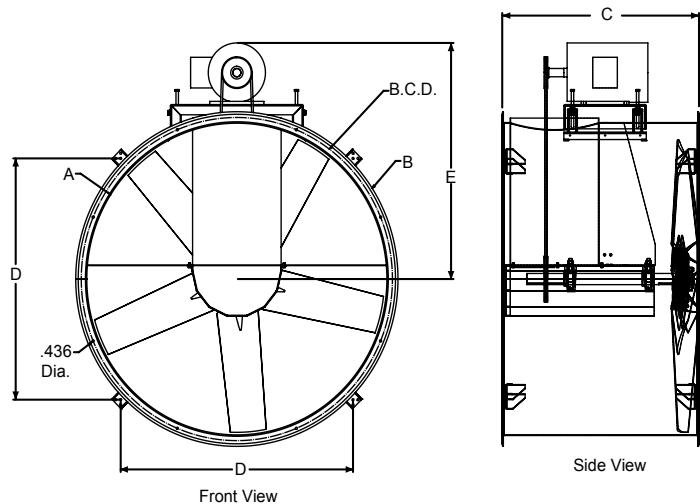

Max. Motor Frame: 184T
Shaft Size: 1"
Housing Gauge: 12
Approximate Weight: 220 lbs.
Flange Holes: 8
Diameter Flange Holes: 7/16"
Finish: Epoxy Coated Galvanized

A	B	C	D	E	B.C.D.
24-3/8	28-9/16	23	21-1/4	28-1/2	25-3/4

A: ID B: OD C: Length E: Max. Height

HP	RPM	Static Pressure (Inches W.G.)																	
		0		0.125		0.25		0.375		0.5		0.625		0.75		0.875		1	
		CFM	BHP	CFM	BHP	CFM	BHP	CFM	BHP	CFM	BHP	CFM	BHP	CFM	BHP	CFM	BHP	CFM	BHP
1/2	800	4768	0.25	4031	0.28	-	-	-	-	-	-	-	-	-	-	-	-	-	-
	850	5066	0.30	4379	0.33	3485	0.35	-	-	-	-	-	-	-	-	-	-	-	-
	900	5364	0.35	4721	0.38	3937	0.41	-	-	-	-	-	-	-	-	-	-	-	-
	950	5662	0.41	5056	0.45	4351	0.48	-	-	-	-	-	-	-	-	-	-	-	-
3/4	975	5811	0.45	5223	0.48	4548	0.51	3555	0.53	-	-	-	-	-	-	-	-	-	-
	1025	6109	0.52	5552	0.56	4929	0.59	4110	0.62	-	-	-	-	-	-	-	-	-	-
	1075	6407	0.60	5878	0.64	5297	0.68	4583	0.70	-	-	-	-	-	-	-	-	-	-
	1125	6705	0.69	6201	0.73	5655	0.77	5014	0.80	4095	0.82	-	-	-	-	-	-	-	-
1	1150	6854	0.73	6362	0.77	5831	0.82	5220	0.85	4390	0.87	-	-	-	-	-	-	-	-
	1200	7152	0.83	6682	0.88	6179	0.92	5615	0.96	4908	0.99	-	-	-	-	-	-	-	-
	1225	7301	0.89	6842	0.93	6351	0.97	5807	1.01	5144	1.05	-	-	-	-	-	-	-	-
	1250	7450	0.94	7001	0.99	6521	1.03	5996	1.07	5370	1.11	4479	1.12	-	-	-	-	-	-
1 1/2	1275	7599	1.00	7159	1.04	6691	1.09	6182	1.13	5587	1.17	4786	1.19	-	-	-	-	-	-
	1325	7897	1.12	7475	1.17	7027	1.22	6548	1.26	6004	1.30	5323	1.33	-	-	-	-	-	-
	1375	8195	1.25	7790	1.30	7360	1.35	6906	1.40	6401	1.44	5801	1.48	-	-	-	-	-	-
	1425	8493	1.39	8103	1.44	7690	1.50	7258	1.55	6785	1.59	6243	1.63	5558	1.66	-	-	-	-
2	1450	8642	1.47	8259	1.52	7854	1.57	7431	1.63	6974	1.67	6454	1.72	5817	1.74	-	-	-	-
	1500	8940	1.63	8571	1.68	8181	1.73	7776	1.79	7343	1.84	6862	1.88	6297	1.92	5561	1.93	-	-
	1525	9089	1.71	8727	1.76	8344	1.82	7947	1.87	7525	1.93	7061	1.97	6524	2.01	5849	2.03	-	-
	1550	9238	1.79	8882	1.85	8506	1.91	8117	1.96	7705	2.02	7256	2.06	6744	2.11	6117	2.13	-	-
3	1625	9685	2.07	9348	2.12	8989	2.18	8622	2.24	8237	2.30	7825	2.35	7371	2.40	6846	2.44	6194	2.46
	1675	9983	2.26	9657	2.32	9309	2.38	8955	2.45	8586	2.51	8195	2.56	7769	2.61	7291	2.66	6723	2.69
	1725	10281	2.47	9965	2.53	9628	2.60	9285	2.66	8931	2.72	8557	2.78	8156	2.84	7714	2.88	7206	2.92
	1775	10579	2.69	10274	2.75	9946	2.82	9614	2.89	9272	2.95	8914	3.01	8534	3.07	8121	3.12	7658	3.17

Performance certified is for installation type A - free inlet, free outlet.
 Performance ratings do not include the effects of appurtenances (accessories).
 Power rating (BHP) does not include transmission losses.



Soler & Palau USA, Div. of Soler & Palau Ventilation Group certifies that the Models TDB shown herein are licensed to bear the AMCA Seal. The ratings shown are based on test and procedures performed in accordance with AMCA Publication 211 and AMCA Publication 311 and comply with the requirement of the AMCA Certified Ratings Program.





Size 30

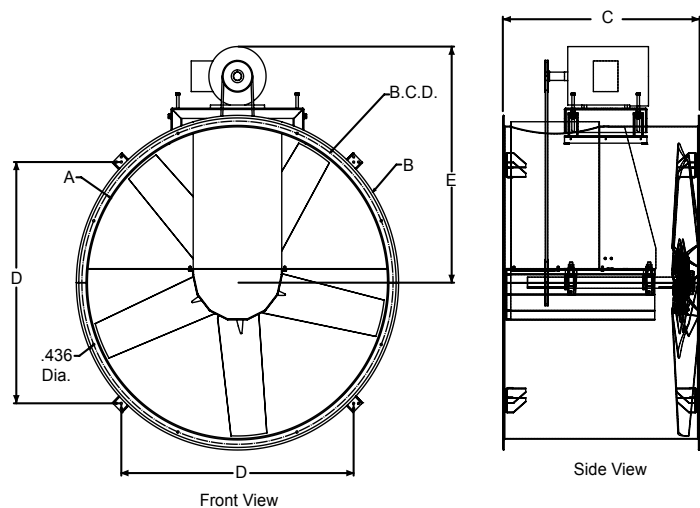

Max. Motor Frame: 254T
Shaft Size: 1-3/16"
Housing Gauge: 12
Approximate Weight: 260 lbs.
Flange Holes: 8
Diameter Flange Holes: 7/16"
Finish: Epoxy Coated Galvanized

A	B	C	D	E	B.C.D.
30-3/8	34-9/16	24	25-1/2	35	32

A: ID B: OD C: Length E: Max. Height

HP	RPM	Static Pressure (Inches W.G.)																			
		0		0.125		0.25		0.375		0.5		0.625		0.75		0.875		1		1.125	
		CFM	BHP	CFM	BHP	CFM	BHP	CFM	BHP	CFM	BHP	CFM	BHP	CFM	BHP	CFM	BHP	CFM	BHP	CFM	BHP
1/2	600	6561	0.24	4936	0.27	-	-	-	-	-	-	-	-	-	-	-	-	-	-	-	-
	650	7108	0.31	5666	0.34	-	-	-	-	-	-	-	-	-	-	-	-	-	-	-	-
	700	7655	0.38	6351	0.42	4239	0.42	-	-	-	-	-	-	-	-	-	-	-	-	-	-
	750	8202	0.47	7008	0.51	5319	0.53	-	-	-	-	-	-	-	-	-	-	-	-	-	-
3/4	775	8475	0.52	7328	0.57	5780	0.58	-	-	-	-	-	-	-	-	-	-	-	-	-	-
	800	8748	0.57	7644	0.62	6209	0.64	-	-	-	-	-	-	-	-	-	-	-	-	-	-
	825	9022	0.62	7957	0.68	6614	0.70	-	-	-	-	-	-	-	-	-	-	-	-	-	-
	850	9295	0.68	8267	0.74	7002	0.77	5007	0.76	-	-	-	-	-	-	-	-	-	-	-	-
1	875	9568	0.74	8574	0.80	7377	0.83	5610	0.83	-	-	-	-	-	-	-	-	-	-	-	-
	900	9842	0.81	8879	0.87	7740	0.90	6147	0.91	-	-	-	-	-	-	-	-	-	-	-	-
	925	10115	0.88	9181	0.94	8094	0.98	6637	0.99	-	-	-	-	-	-	-	-	-	-	-	-
	950	10389	0.95	9482	1.02	8441	1.06	7094	1.07	4911	1.05	-	-	-	-	-	-	-	-	-	-
1 1/2	975	10662	1.03	9781	1.10	8781	1.14	7524	1.16	5612	1.14	-	-	-	-	-	-	-	-	-	-
	1025	11209	1.20	10375	1.27	9446	1.32	8330	1.34	6800	1.34	-	-	-	-	-	-	-	-	-	-
	1075	11755	1.38	10963	1.46	10095	1.51	9084	1.54	7793	1.55	-	-	-	-	-	-	-	-	-	-
	1100	12029	1.48	11256	1.56	10414	1.62	9447	1.65	8244	1.66	6532	1.64	-	-	-	-	-	-	-	-
2	1125	12302	1.58	11548	1.66	10731	1.72	9802	1.76	8674	1.78	7136	1.76	-	-	-	-	-	-	-	-
	1150	12576	1.69	11838	1.77	11045	1.84	10151	1.88	9086	1.90	7688	1.89	-	-	-	-	-	-	-	-
	1175	12849	1.80	12128	1.89	11356	1.95	10495	2.00	9484	2.02	8199	2.02	-	-	-	-	-	-	-	-
	1200	13122	1.92	12417	2.01	11666	2.08	10834	2.13	9871	2.15	8678	2.16	7027	2.13	-	-	-	-	-	-
3	1225	13396	2.04	12706	2.13	11973	2.20	11168	2.26	10248	2.29	9132	2.30	7645	2.28	-	-	-	-	-	-
	1275	13943	2.30	13281	2.40	12583	2.47	11826	2.53	10977	2.57	9984	2.59	8738	2.58	-	-	-	-	-	-
	1325	14489	2.58	13853	2.68	13188	2.76	12471	2.83	11681	2.88	10780	2.90	9699	2.90	8302	2.88	-	-	-	-
	1375	15036	2.89	14424	2.99	13787	3.08	13107	3.15	12366	3.20	11538	3.23	10576	3.25	9394	3.23	-	-	-	-
5	1400	15309	3.05	14709	3.15	14085	3.24	13421	3.32	12702	3.37	11905	3.41	10991	3.43	9891	3.42	-	-	-	-
	1475	16130	3.56	15560	3.68	14972	3.77	14353	3.85	13691	3.92	12971	3.97	12170	4.00	11250	4.01	10146	3.99	-	-
	1550	16950	4.14	16408	4.26	15852	4.36	15271	4.45	14656	4.52	13997	4.58	13278	4.62	12478	4.65	11560	4.65	-	-
	1600	17497	4.55	16972	4.67	16436	4.78	15877	4.87	15289	4.96	14664	5.02	13989	5.07	13249	5.10	12418	5.12	10298	5.08

Performance certified is for installation type A - free inlet, free outlet.
 Performance ratings do not include the effects of appurtenances (accessories).
 Power rating (BHP) does not include transmission losses.



Soler & Palau USA, Div. of Soler & Palau Ventilation Group certifies that the Models TDB shown herein are licensed to bear the AMCA Seal. The ratings shown are based on test and procedures performed in accordance with AMCA Publication 211 and AMCA Publication 311 and comply with the requirement of the AMCA Certified Ratings Program.





Size 34

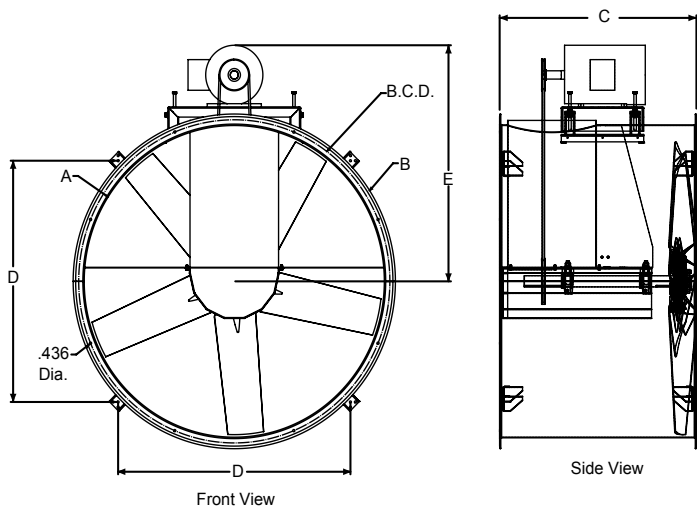

Max. Motor Frame: 254T
Shaft Size: 1-7/16"
Housing Gauge: 12
Approximate Weight: 310 lbs.
Flange Holes: 8
Diameter Flange Holes: 7/16"
Finish: Epoxy Coated Galvanized

A	B	C	D	E	B.C.D.
34-3/8	38-9/16	27	28-5/8	37	36-3/8

A: ID B: OD C: Length E: Max. Height

HP	RPM	Static Pressure (Inches W.G.)																					
		0		0.125		0.25		0.375		0.5		0.625		0.75		0.875		1		1.125		1.5	
		CFM	BHP	CFM	BHP	CFM	BHP	CFM	BHP	CFM	BHP	CFM	BHP	CFM	BHP	CFM	BHP	CFM	BHP	CFM	BHP	CFM	BHP
3/4	600	9375	0.43	7491	0.48	-	-	-	-	-	-	-	-	-	-	-	-	-	-	-	-	-	-
	625	9765	0.49	7994	0.54	-	-	-	-	-	-	-	-	-	-	-	-	-	-	-	-	-	-
	650	10156	0.55	8483	0.60	5890	0.60	-	-	-	-	-	-	-	-	-	-	-	-	-	-	-	-
	675	10547	0.61	8960	0.67	6580	0.67	-	-	-	-	-	-	-	-	-	-	-	-	-	-	-	-
1	700	10937	0.69	9428	0.75	7235	0.75	-	-	-	-	-	-	-	-	-	-	-	-	-	-	-	-
	725	11328	0.76	9887	0.83	7858	0.84	5118	0.84	-	-	-	-	-	-	-	-	-	-	-	-	-	-
	750	11718	0.84	10339	0.91	8453	0.93	5870	0.92	-	-	-	-	-	-	-	-	-	-	-	-	-	-
	775	12109	0.93	10786	1.01	9024	1.03	6609	1.02	-	-	-	-	-	-	-	-	-	-	-	-	-	-
1 1/2	800	12500	1.02	11228	1.10	9573	1.13	7324	1.12	-	-	-	-	-	-	-	-	-	-	-	-	-	-
	825	12890	1.12	11665	1.21	10106	1.24	8013	1.23	5542	1.25	-	-	-	-	-	-	-	-	-	-	-	-
	850	13281	1.23	12098	1.32	10624	1.35	8673	1.35	6297	1.35	-	-	-	-	-	-	-	-	-	-	-	-
	875	13672	1.34	12528	1.43	11129	1.47	9306	1.47	7046	1.47	-	-	-	-	-	-	-	-	-	-	-	-
2	900	14062	1.46	12956	1.55	11623	1.60	9915	1.61	7779	1.59	5523	1.64	-	-	-	-	-	-	-	-	-	-
	925	14453	1.58	13380	1.68	12108	1.74	10502	1.75	8492	1.73	6276	1.76	-	-	-	-	-	-	-	-	-	-
	950	14843	1.71	13802	1.82	12585	1.88	11070	1.89	9181	1.88	7031	1.89	4989	1.99	-	-	-	-	-	-	-	-
	975	15234	1.85	14223	1.96	13055	2.02	11621	2.05	9846	2.03	7780	2.03	5725	2.11	-	-	-	-	-	-	-	-
3	1025	16015	2.15	15057	2.27	13977	2.34	12681	2.38	11106	2.37	9235	2.35	7229	2.38	5357	2.50	-	-	-	-	-	-
	1050	16406	2.31	15472	2.43	14430	2.51	13194	2.55	11705	2.55	9934	2.53	7982	2.54	6091	2.64	-	-	-	-	-	-
	1100	17187	2.66	16298	2.79	15324	2.88	14191	2.93	12850	2.94	11265	2.92	9462	2.91	7593	2.95	-	-	-	-	-	-
	1125	17578	2.85	16709	2.98	15766	3.07	14677	3.13	13401	3.14	11899	3.13	10178	3.11	8347	3.13	6586	3.24	-	-	-	-
5	1175	18359	3.24	17528	3.38	16641	3.48	15630	3.55	14465	3.58	13111	3.58	11554	3.55	9837	3.55	8088	3.60	-	-	-	-
	1225	19140	3.67	18343	3.82	17504	3.93	16561	4.01	15489	4.05	14259	4.06	12850	4.04	11271	4.02	9594	4.03	-	-	-	-
	1275	19921	4.14	19155	4.30	18360	4.42	17475	4.50	16480	4.55	15354	4.57	14075	4.57	12635	4.54	11065	4.53	-	-	-	-
	1325	20703	4.65	19964	4.81	19208	4.94	18373	5.03	17446	5.10	16407	5.13	15238	5.13	13926	5.11	12478	5.09	9384	5.14	-	-
7 1/2	1375	21484	5.20	20771	5.37	20049	5.50	19260	5.61	18390	5.68	17426	5.72	16351	5.74	15151	5.73	13823	5.70	10888	5.70	-	-
	1425	22265	5.78	21576	5.96	20885	6.10	20136	6.22	19316	6.30	18416	6.36	17421	6.39	16319	6.38	15101	6.36	12357	6.32	-	-
	1475	23046	6.42	22378	6.60	21717	6.75	21003	6.87	20228	6.97	19383	7.04	18457	7.07	17438	7.08	16318	7.07	13774	7.02	10990	7.06
	1525	23827	7.09	23179	7.28	22544	7.44	21862	7.57	21127	7.68	20330	7.76	19464	7.81	18517	7.83	17482	7.82	15131	7.77	12484	7.76

Performance certified is for installation type A - free inlet, free outlet.
 Performance ratings do not include the effects of appurtenances (accessories).
 Power rating (BHP) does not include transmission losses.



Soler & Palau USA, Div. of Soler & Palau Ventilation Group certifies that the Models TDB shown herein are licensed to bear the AMCA Seal. The ratings shown are based on test and procedures performed in accordance with AMCA Publication 211 and AMCA Publication 311 and comply with the requirement of the AMCA Certified Ratings Program.





Size 36

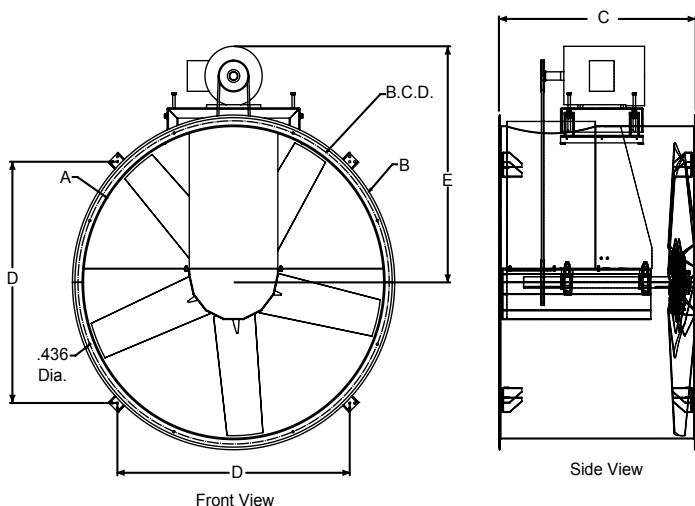

Max. Motor Frame: 254T
Shaft Size: 1-7/16"
Housing Gauge: 10
Approximate Weight: 410 lbs.
Flange Holes: 8
Diameter Flange Holes: 7/16"
Finish: Epoxy Coated Galvanized



A	B	C	D	E	B.C.D.
36-3/8	40-5/8	29	29-13/16	38	38
A: ID B: OD C: Length E: Max. Height					

HP	RPM	Static Pressure (Inches W.G.)																							
		0		0.125		0.25		0.375		0.5		0.625		0.75		0.875		1		1.125		1.5			
		CFM	BHP	CFM	BHP	CFM	BHP	CFM	BHP	CFM	BHP	CFM	BHP	CFM	BHP	CFM	BHP	CFM	BHP	CFM	BHP	CFM	BHP		
3/4	650	10196	0.41	8534	0.49	-	-	-	-	-	-	-	-	-	-	-	-	-	-	-	-	-	-	-	
	675	10588	0.46	8997	0.54	6993	0.59	-	-	-	-	-	-	-	-	-	-	-	-	-	-	-	-	-	
	700	10980	0.52	9454	0.60	7598	0.66	-	-	-	-	-	-	-	-	-	-	-	-	-	-	-	-	-	
	725	11372	0.57	9905	0.66	8170	0.72	-	-	-	-	-	-	-	-	-	-	-	-	-	-	-	-	-	
1	750	11764	0.63	10352	0.73	8717	0.79	6390	0.81	-	-	-	-	-	-	-	-	-	-	-	-	-	-	-	
	775	12156	0.70	10794	0.80	9245	0.87	7169	0.90	-	-	-	-	-	-	-	-	-	-	-	-	-	-	-	
	800	12549	0.77	11233	0.87	9758	0.95	7872	0.99	-	-	-	-	-	-	-	-	-	-	-	-	-	-	-	
	825	12941	0.84	11668	0.95	10259	1.03	8521	1.08	5878	1.08	-	-	-	-	-	-	-	-	-	-	-	-	-	
1 1/2	875	13725	1.01	12531	1.12	11232	1.21	9714	1.27	7669	1.29	-	-	-	-	-	-	-	-	-	-	-	-	-	
	900	14117	1.10	12958	1.21	11707	1.31	10273	1.38	8427	1.41	-	-	-	-	-	-	-	-	-	-	-	-	-	
	925	14509	1.19	13384	1.31	12176	1.41	10814	1.49	9123	1.53	-	-	-	-	-	-	-	-	-	-	-	-	-	
	950	14901	1.29	13808	1.41	12639	1.52	11340	1.60	9773	1.65	7623	1.65	-	-	-	-	-	-	-	-	-	-	-	
2	975	15294	1.39	14230	1.52	13098	1.63	11854	1.72	10390	1.78	8470	1.79	-	-	-	-	-	-	-	-	-	-	-	
	1000	15686	1.50	14650	1.64	13552	1.75	12358	1.84	10979	1.91	9239	1.93	-	-	-	-	-	-	-	-	-	-	-	
	1025	16078	1.62	15070	1.76	14003	1.88	12852	1.97	11547	2.04	9950	2.08	7772	2.07	-	-	-	-	-	-	-	-	-	
	1050	16470	1.74	15487	1.88	14450	2.00	13340	2.11	12097	2.18	10617	2.23	8677	2.23	6015	2.21	-	-	-	-	-	-	-	
3	1100	17254	2.00	16319	2.15	15335	2.28	14295	2.39	13157	2.48	11853	2.55	10255	2.57	8119	2.55	-	-	-	-	-	-	-	
	1125	17646	2.14	16734	2.29	15774	2.43	14765	2.55	13671	2.64	12435	2.71	10959	2.75	9053	2.74	-	-	-	-	-	-	-	
	1150	18039	2.29	17147	2.44	16210	2.58	15230	2.70	14175	2.81	12999	2.88	11624	2.93	9904	2.94	-	-	-	-	-	-	-	
	1175	18431	2.44	17560	2.60	16644	2.74	15691	2.87	14672	2.98	13548	3.06	12258	3.11	10687	3.13	8642	3.11	-	-	-	-	-	
5	1225	19215	2.77	18382	2.93	17507	3.08	16602	3.22	15646	3.34	14610	3.43	13452	3.50	12104	3.54	10443	3.55	-	-	-	-	-	
	1275	19999	3.12	19202	3.29	18364	3.45	17501	3.60	16598	3.72	15633	3.83	14577	3.92	13384	3.98	11981	4.00	8060	3.96	-	-	-	
	1350	21176	3.70	20426	3.88	19637	4.06	18830	4.22	17994	4.36	17114	4.48	16172	4.59	15142	4.67	13985	4.73	11010	4.74	-	-	-	
	1400	21960	4.13	21240	4.32	20480	4.50	19706	4.67	18908	4.82	18074	4.95	17191	5.07	16241	5.17	15196	5.24	12640	5.30	-	-	-	
7 1/2	1450	22744	4.59	22051	4.78	21319	4.97	20574	5.15	19810	5.31	19017	5.45	18185	5.58	17298	5.69	16339	5.78	14084	5.88	-	-	-	
	1500	23529	5.08	22861	5.28	22154	5.48	21437	5.66	20703	5.83	19946	5.99	19156	6.13	18323	6.25	17434	6.35	15400	6.49	12780	6.51	-	
	1550	24313	5.60	23669	5.81	22985	6.02	22293	6.21	21588	6.39	20862	6.55	20110	6.70	19323	6.84	18490	6.95	16628	7.13	14337	7.19	-	
	1600	25097	6.16	24476	6.38	23814	6.59	23145	6.79	22465	6.98	21768	7.15	21049	7.31	20301	7.46	19516	7.59	17792	7.79	15743	7.90	-	

Performance certified is for installation type A - free inlet, free outlet.
 Performance ratings do not include the effects of appurtenances (accessories).
 Power rating (BHP) does not include transmission losses.



Soler & Palau USA, Div. of Soler & Palau Ventilation Group certifies that the Models TDB shown herein are licensed to bear the AMCA Seal. The ratings shown are based on test and procedures performed in accordance with AMCA Publication 211 and AMCA Publication 311 and comply with the requirement of the AMCA Certified Ratings Program.





MODEL TDB
BELT DRIVE TUBEAXIAL DUCT FAN



Size 42

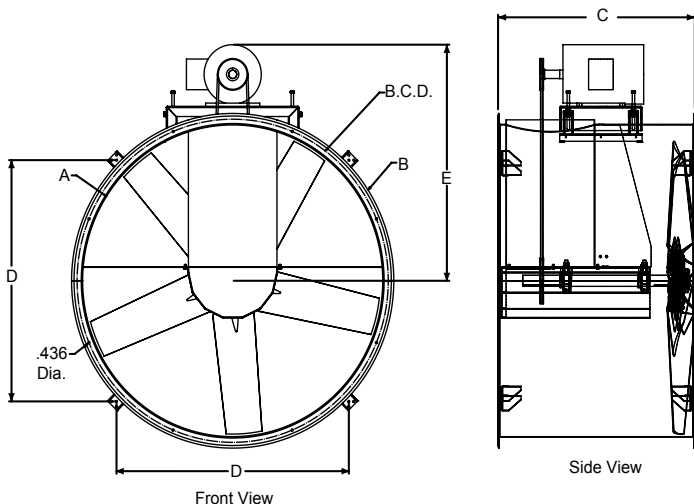

Max. Motor Frame: 254T
Shaft Size: 1-7/16"
Housing Gauge: 10
Approximate Weight: 480 lbs.
Flange Holes: 8
Diameter Flange Holes: 7/16"
Finish: Epoxy Coated
 Galvanized



A	B	C	D	E	B.C.D.
42-1/2	47	30	34-1/8	42	44-1/4

A: ID B: OD C: Length E: Max. Height

HP	RPM	Static Pressure (Inches W.G.)																					
		0		0.125		0.25		0.375		0.5		0.625		0.75		0.875		1		1.25		1.5	
		CFM	BHP	CFM	BHP	CFM	BHP	CFM	BHP	CFM	BHP	CFM	BHP	CFM	BHP	CFM	BHP	CFM	BHP	CFM	BHP	CFM	BHP
1	480	11943	0.45	9569	0.52	-	-	-	-	-	-	-	-	-	-	-	-	-	-	-	-	-	-
	520	12939	0.57	10805	0.66	7231	0.68	-	-	-	-	-	-	-	-	-	-	-	-	-	-	-	-
	560	13934	0.71	11987	0.81	9272	0.85	-	-	-	-	-	-	-	-	-	-	-	-	-	-	-	-
	600	14929	0.88	13134	0.98	10859	1.04	-	-	-	-	-	-	-	-	-	-	-	-	-	-	-	-
1 1/2	640	15924	1.06	14256	1.18	12264	1.25	9049	1.26	-	-	-	-	-	-	-	-	-	-	-	-	-	-
	660	16422	1.17	14810	1.29	12926	1.36	10151	1.39	-	-	-	-	-	-	-	-	-	-	-	-	-	-
	680	16920	1.28	15359	1.40	13569	1.49	11098	1.52	-	-	-	-	-	-	-	-	-	-	-	-	-	-
	700	17417	1.39	15905	1.52	14198	1.61	11951	1.66	-	-	-	-	-	-	-	-	-	-	-	-	-	-
2	720	17915	1.51	16448	1.65	14813	1.75	12742	1.80	9165	1.79	-	-	-	-	-	-	-	-	-	-	-	-
	740	18412	1.64	16987	1.78	15419	1.89	13489	1.95	10509	1.96	-	-	-	-	-	-	-	-	-	-	-	-
	760	18910	1.78	17525	1.93	16015	2.03	14202	2.10	11615	2.12	-	-	-	-	-	-	-	-	-	-	-	-
3	800	19905	2.08	18592	2.23	17186	2.35	15558	2.43	13456	2.48	-	-	-	-	-	-	-	-	-	-	-	-
	820	20403	2.24	19123	2.40	17762	2.52	16209	2.61	14270	2.66	11293	2.66	-	-	-	-	-	-	-	-	-	-
	840	20901	2.40	19652	2.57	18333	2.70	16846	2.80	15040	2.86	12473	2.86	-	-	-	-	-	-	-	-	-	-
	860	21398	2.58	20179	2.75	18899	2.88	17472	2.99	15775	3.06	13498	3.08	-	-	-	-	-	-	-	-	-	-
5	900	22394	2.96	21229	3.14	20019	3.28	18694	3.40	17171	3.48	15277	3.52	12482	3.51	-	-	-	-	-	-	-	-
	940	23389	3.37	22274	3.56	21126	3.71	19886	3.84	18495	3.94	16847	4.00	14685	4.02	11117	3.98	-	-	-	-	-	-
	980	24384	3.82	23314	4.02	22222	4.18	21054	4.32	19768	4.43	18294	4.51	16489	4.55	13967	4.54	-	-	-	-	-	-
	1020	25379	4.30	24351	4.51	23308	4.69	22203	4.84	21003	4.96	19661	5.06	18087	5.12	16088	5.14	-	-	-	-	-	-
7 1/2	1060	26375	4.83	25384	5.05	24386	5.24	23336	5.40	22209	5.53	20970	5.64	19562	5.72	17872	5.76	15639	5.75	-	-	-	-
	1100	27370	5.40	26415	5.63	25457	5.82	24456	5.99	23391	6.14	22237	6.26	20953	6.36	19471	6.42	17649	6.44	-	-	-	-
	1140	28365	6.01	27442	6.25	26522	6.45	25564	6.63	24554	6.79	23470	6.93	22285	7.04	20953	7.12	19389	7.16	-	-	-	-
10	1180	29360	6.66	28468	6.91	27582	7.13	26663	7.32	25700	7.49	24677	7.64	23573	7.76	22355	7.86	20969	7.92	-	-	-	-
	1200	29858	7.01	28979	7.26	28110	7.48	27210	7.68	26268	7.85	25273	8.01	24203	8.14	23033	8.24	21718	8.32	18279	8.36	-	-
	1240	30853	7.73	30002	8.00	29162	8.23	28297	8.43	27396	8.62	26449	8.78	25441	8.93	24353	9.05	23154	9.14	20195	9.23	-	-
	1260	31351	8.11	30512	8.38	29687	8.61	28837	8.83	27955	9.02	27031	9.19	26051	9.34	24998	9.47	23848	9.57	21068	9.68	-	-
	1300	32346	8.91	31532	9.19	30734	9.43	29915	9.66	29067	9.86	28183	10.04	27253	10.20	26263	10.34	25195	10.46	22700	10.61	19251	10.62

Performance certified is for installation type A - free inlet, free outlet.
 Performance ratings do not include the effects of appurtenances (accessories).
 Power rating (BHP) does not include transmission losses.



Soler & Palau USA, Div. of Soler & Palau Ventilation Group certifies that the Models TDB shown herein are licensed to bear the AMCA Seal. The ratings shown are based on test and procedures performed in accordance with AMCA Publication 211 and AMCA Publication 311 and comply with the requirement of the AMCA Certified Ratings Program.





Size 48

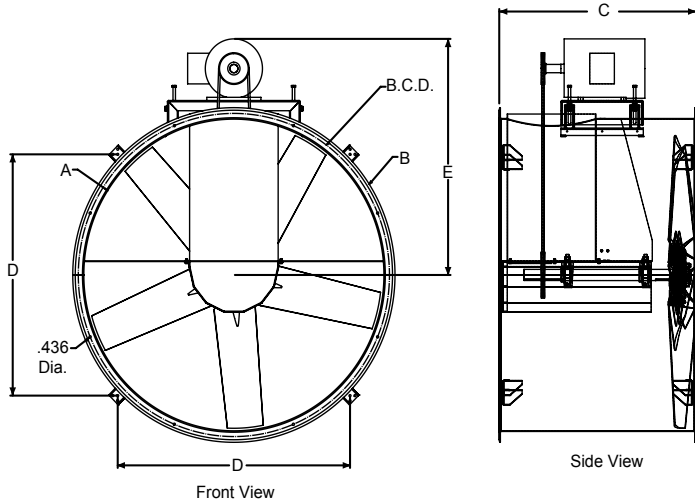

Max. Motor Frame: 284T
Shaft Size: 1-7/16"
Housing Gauge: 10
Approximate Weight: 600 lbs.
Flange Holes: 8
Diameter Flange Holes: 7/16"
Finish: Epoxy Coated
 Galvanized

A	B	C	D	E	B.C.D.
48-1/2	53	33	38-3/8	45	50-3/4

A: ID B: OD C: Length E: Max. Height

HP	RPM	Static Pressure (Inches W.G.)																							
		0		0.125		0.25		0.375		0.5		0.625		0.75		0.875		1		1.125		1.25			
		CFM	BHP	CFM	BHP	CFM	BHP	CFM	BHP	CFM	BHP	CFM	BHP	CFM	BHP	CFM	BHP	CFM	BHP	CFM	BHP	CFM	BHP		
1 1/2	460	17884	0.76	15363	0.93	11881	1.03	-	-	-	-	-	-	-	-	-	-	-	-	-	-	-	-	-	
	480	18662	0.87	16265	1.04	13143	1.16	-	-	-	-	-	-	-	-	-	-	-	-	-	-	-	-	-	
	500	19439	0.98	17153	1.17	14304	1.30	-	-	-	-	-	-	-	-	-	-	-	-	-	-	-	-	-	
	520	20217	1.10	18030	1.30	15397	1.44	11234	1.51	-	-	-	-	-	-	-	-	-	-	-	-	-	-	-	
2	540	20995	1.23	18898	1.44	16441	1.59	12890	1.68	-	-	-	-	-	-	-	-	-	-	-	-	-	-	-	
	560	21772	1.38	19758	1.59	17448	1.76	14324	1.86	-	-	-	-	-	-	-	-	-	-	-	-	-	-	-	
	580	22550	1.53	20610	1.75	18427	1.93	15616	2.05	10970	2.10	-	-	-	-	-	-	-	-	-	-	-	-	-	
	600	23327	1.69	21457	1.93	19384	2.11	16813	2.25	12932	2.32	-	-	-	-	-	-	-	-	-	-	-	-	-	
3	620	24105	1.87	22299	2.11	20322	2.31	17943	2.46	14611	2.55	-	-	-	-	-	-	-	-	-	-	-	-	-	
	640	24882	2.05	23135	2.31	21245	2.51	19024	2.68	16085	2.79	-	-	-	-	-	-	-	-	-	-	-	-	-	
	660	25660	2.25	23968	2.51	22156	2.73	20066	2.91	17420	3.04	13439	3.09	-	-	-	-	-	-	-	-	-	-	-	
	680	26438	2.46	24797	2.73	23055	2.96	21078	3.15	18658	3.29	15263	3.37	10161	3.44	-	-	-	-	-	-	-	-	-	
5	720	27993	2.92	26445	3.21	24826	3.46	23033	3.68	20944	3.85	18291	3.96	14426	4.02	-	-	-	-	-	-	-	-	-	
	760	29548	3.44	28083	3.75	26567	4.01	24920	4.25	23062	4.45	20845	4.60	17946	4.69	13734	4.74	-	-	-	-	-	-	-	
	780	30325	3.72	28898	4.03	27429	4.31	25844	4.56	24078	4.77	22017	4.94	19430	5.05	15811	5.10	-	-	-	-	-	-	-	
	820	31881	4.32	30522	4.65	29137	4.95	27661	5.22	26049	5.45	24228	5.65	22069	5.80	19314	5.90	15488	5.94	11164	6.11	-	-	-	
7 1/2	860	33436	4.98	32140	5.34	30828	5.65	29444	5.94	27954	6.20	26311	6.42	24436	6.60	22188	6.74	19294	6.82	15382	6.87	11358	7.08	-	
	880	34213	5.34	32946	5.70	31669	6.03	30325	6.32	28888	6.59	27318	6.83	25551	7.03	23482	7.18	20910	7.28	17486	7.33	13339	7.45		
	900	34991	5.71	33751	6.08	32506	6.42	31200	6.73	29812	7.00	28306	7.25	26633	7.47	24709	7.64	22388	7.76	19398	7.83	15502	7.89		
	940	36546	6.51	35357	6.90	34171	7.25	32935	7.58	31632	7.88	30237	8.15	28716	8.39	27017	8.59	25055	8.76	22682	8.87	19643	8.93		
10	960	37324	6.93	36159	7.33	34999	7.69	33795	8.03	32530	8.34	31183	8.62	29726	8.88	28116	9.10	26287	9.27	24127	9.41	21443	9.49		
	980	38101	7.37	36959	7.78	35826	8.15	34651	8.50	33421	8.82	32118	9.12	30718	9.38	29185	9.61	27468	9.81	25480	9.96	23078	10.07		
	1000	38879	7.83	37759	8.25	36650	8.63	35503	8.99	34307	9.32	33044	9.63	31695	9.90	30231	10.15	28608	10.36	26762	10.53	24583	10.66		

Performance certified is for installation type A - free inlet, free outlet.
 Performance ratings do not include the effects of appurtenances (accessories).
 Power rating (BHP) does not include transmission losses.



Soler & Palau USA, Div. of Soler & Palau Ventilation Group certifies that the Models TDB shown herein are licensed to bear the AMCA Seal. The ratings shown are based on test and procedures performed in accordance with AMCA Publication 211 and AMCA Publication 311 and comply with the requirement of the AMCA Certified Ratings Program.





MODEL TDB
BELT DRIVE TUBEAXIAL DUCT FAN



Size 54

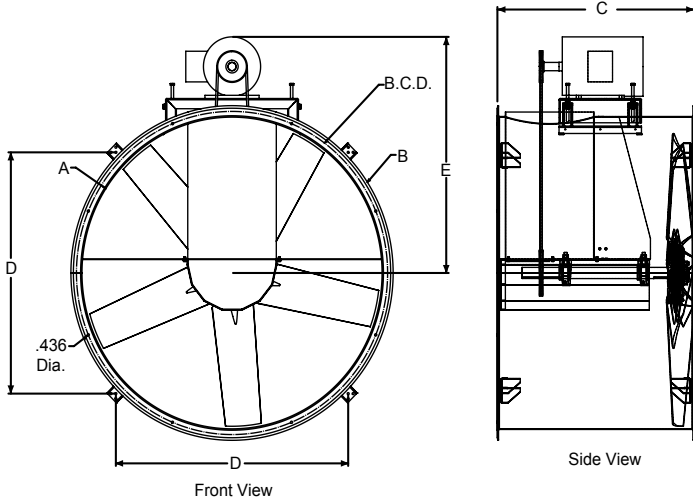

Max. Motor Frame: 284T
Shaft Size: 2-3/16"
Housing Gauge: 10
Approximate Weight: 730 lbs.
Flange Holes: 8
Diameter Flange Holes: 7/16"
Finish: Epoxy Coated Galvanized



A	B	C	D	E	B.C.D.
55	59-1/2	38	43	48	57-1/4

A: ID B: OD C: Length E: Max. Height

HP	RPM	Static Pressure (Inches W.G.)																					
		0		0.125		0.25		0.375		0.5		0.625		0.75		0.875		1		1.125		1.25	
		CFM	BHP	CFM	BHP	CFM	BHP	CFM	BHP	CFM	BHP	CFM	BHP	CFM	BHP	CFM	BHP	CFM	BHP	CFM	BHP	CFM	BHP
3	460	29774	1.94	26461	2.06	21377	2.04	-	-	-	-	-	-	-	-	-	-	-	-	-	-	-	-
	480	31068	2.20	27937	2.33	23415	2.33	-	-	-	-	-	-	-	-	-	-	-	-	-	-	-	-
	500	32363	2.49	29392	2.63	25300	2.64	18049	2.56	-	-	-	-	-	-	-	-	-	-	-	-	-	-
	520	33657	2.80	30829	2.95	27081	2.98	20981	2.89	-	-	-	-	-	-	-	-	-	-	-	-	-	-
5	560	36246	3.50	33660	3.67	30429	3.73	25818	3.67	-	-	-	-	-	-	-	-	-	-	-	-	-	-
	580	37541	3.89	35060	4.07	32028	4.14	27898	4.10	-	-	-	-	-	-	-	-	-	-	-	-	-	-
	600	38835	4.30	36450	4.49	33592	4.58	29839	4.56	24166	4.44	-	-	-	-	-	-	-	-	-	-	-	-
	620	40130	4.75	37832	4.95	35126	5.05	31677	5.05	26754	4.94	-	-	-	-	-	-	-	-	-	-	-	-
7 1/2	660	42719	5.72	40577	5.94	38124	6.07	35139	6.10	31225	6.03	25491	5.90	-	-	-	-	-	-	-	-	-	-
	680	44013	6.26	41940	6.49	39596	6.63	36791	6.68	33228	6.62	28247	6.49	-	-	-	-	-	-	-	-	-	-
	700	45308	6.83	43299	7.07	41052	7.22	38405	7.28	35126	7.25	30732	7.12	-	-	-	-	-	-	-	-	-	-
	720	46602	7.43	44654	7.68	42495	7.84	39986	7.92	36943	7.91	33009	7.80	27485	7.66	-	-	-	-	-	-	-	-
10	740	47897	8.07	46005	8.33	43927	8.50	41539	8.59	38697	8.60	35127	8.50	30295	8.35	-	-	-	-	-	-	-	-
	760	49191	8.74	47352	9.01	45349	9.19	43070	9.30	40399	9.32	37124	9.25	32847	9.10	-	-	-	-	-	-	-	-
	780	50486	9.45	48696	9.72	46762	9.92	44581	10.04	42058	10.08	39028	10.03	35190	9.89	30027	9.74	-	-	-	-	-	-
	800	51780	10.20	50038	10.48	48167	10.69	46075	10.82	43682	10.88	40858	10.84	37372	10.72	32817	10.55	-	-	-	-	-	-
15	840	54369	11.80	52712	12.11	50956	12.33	49019	12.49	46844	12.58	44347	12.58	41388	12.50	37727	12.34	32986	12.17	-	-	-	-
	860	55664	12.67	54046	12.98	52342	13.22	50472	13.39	48391	13.49	46026	13.51	43268	13.45	39931	13.31	35711	13.12	30312	13.04	-	-
	880	56958	13.57	55378	13.89	53722	14.14	51915	14.32	49918	14.44	47670	14.48	45084	14.43	42014	14.31	38223	14.13	33394	13.98	-	-
	900	58253	14.52	56708	14.85	55098	15.11	53349	15.30	51428	15.43	49285	15.48	46847	15.46	44000	15.36	40559	15.19	36250	15.00	30906	14.96

Performance certified is for installation type A - free inlet, free outlet.
 Performance ratings do not include the effects of appurtenances (accessories).
 Power rating (BHP) does not include transmission losses.



Soler & Palau USA, Div. of Soler & Palau Ventilation Group certifies that the Models TDB shown herein are licensed to bear the AMCA Seal. The ratings shown are based on test and procedures performed in accordance with AMCA Publication 211 and AMCA Publication 311 and comply with the requirement of the AMCA Certified Ratings Program.





MODEL TDB
BELT DRIVE TUBEAXIAL DUCT FAN



Size 60

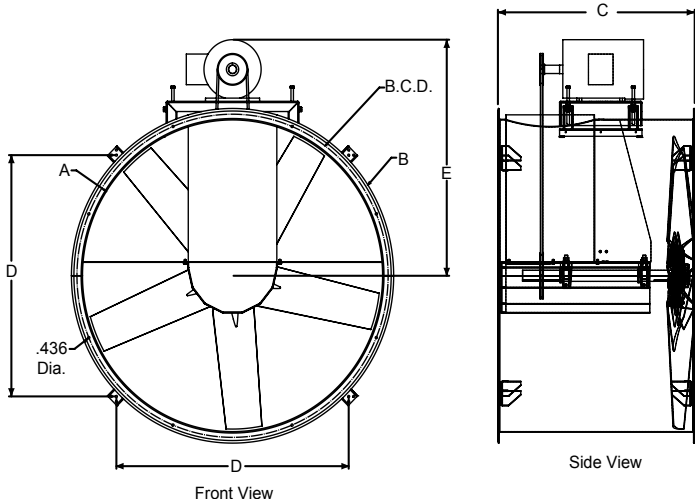

Max. Motor Frame: 286T
Shaft Size: 2-3/16"
Housing Gauge: 10
Approximate Weight: 798 lbs.
Flange Holes: 8
Diameter Flange Holes: 7/16"
Finish: Epoxy Coated Galvanized



A	B	C	D	E	B.C.D.
---	---	---	---	---	--------

61 65-1/2 40 47-1/4 54-1/2 63-1/4

A: ID B: OD C: Length E: Max. Height

HP	RPM	Static Pressure (Inches W.G.)																			
		0		0.125		0.25		0.375		0.5		0.625		0.75		0.875		1		1.125	
		CFM	BHP	CFM	BHP	CFM	BHP	CFM	BHP	CFM	BHP	CFM	BHP	CFM	BHP	CFM	BHP	CFM	BHP	CFM	BHP
5	520	43617	3.47	40228	3.71	36159	3.81	30434	3.76	-	-	-	-	-	-	-	-	-	-	-	-
	540	45294	3.89	42045	4.14	38237	4.26	33147	4.24	-	-	-	-	-	-	-	-	-	-	-	-
	560	46972	4.34	43850	4.60	40265	4.74	35660	4.75	28680	4.62	-	-	-	-	-	-	-	-	-	-
	580	48649	4.82	45643	5.10	42254	5.26	38031	5.29	32080	5.18	-	-	-	-	-	-	-	-	-	-
7 1/2	600	50327	5.33	47427	5.63	44209	5.80	40299	5.86	35079	5.78	26748	5.63	-	-	-	-	-	-	-	-
	620	52004	5.89	49202	6.20	46136	6.39	42488	6.46	37812	6.41	30921	6.25	-	-	-	-	-	-	-	-
	640	53682	6.47	50969	6.80	48041	7.00	44614	7.10	40362	7.08	34492	6.93	-	-	-	-	-	-	-	-
	660	55360	7.10	52730	7.44	49925	7.66	46691	7.78	42778	7.78	37641	7.66	-	-	-	-	-	-	-	-
10	680	57037	7.77	54485	8.12	51792	8.36	48726	8.49	45093	8.52	40504	8.43	34030	8.25	-	-	-	-	-	-
	700	58715	8.47	56235	8.84	53645	9.09	50726	9.25	47328	9.30	43164	9.24	37603	9.07	-	-	-	-	-	-
	720	60392	9.22	57980	9.60	55484	9.87	52697	10.04	49500	10.12	45676	10.08	40784	9.94	33849	9.75	-	-	-	-
	740	62070	10.01	59721	10.40	57311	10.69	54644	10.88	51620	10.98	48075	10.97	43690	10.85	37791	10.65	-	-	-	-
15	760	63747	10.84	61457	11.25	59128	11.55	56568	11.76	53698	11.88	50385	11.90	46397	11.81	41265	11.62	34071	11.44	-	-
	780	65425	11.72	63190	12.14	60936	12.46	58474	12.69	55738	12.82	52625	12.87	48957	12.81	44399	12.65	38286	12.43	-	-
	800	67103	12.65	64920	13.08	62735	13.41	60363	13.66	57748	13.81	54807	13.88	51402	13.85	47289	13.72	42000	13.50	-	-
	820	68780	13.62	66647	14.07	64527	14.41	62237	14.67	59731	14.85	56940	14.94	53756	14.94	49997	14.83	45329	14.64	-	-
20*	840	70458	14.64	68371	15.11	66312	15.46	64099	15.74	61691	15.94	59033	16.05	56038	16.07	52567	15.99	48376	15.82	43020	15.58
	860	72135	15.71	70093	16.19	68091	16.56	65948	16.85	63631	17.07	61091	17.20	58259	17.25	55027	17.20	51214	17.06	46500	16.83
	880	73813	16.83	71812	17.33	69864	17.71	67787	18.02	65552	18.25	63118	18.41	60430	18.47	57401	18.45	53893	18.34	49673	18.14
	900	75490	18.00	73529	18.52	71632	18.91	69616	19.24	67457	19.49	65120	19.66	62558	19.75	59703	19.76	56447	19.67	52618	19.50

Performance certified is for installation type A - free inlet, free outlet.
 Performance ratings do not include the effects of appurtenances (accessories).
 Power rating (BHP) does not include transmission losses.

***20HP motor is available by Special Quote only. Please contact Factory for more information.**



Soler & Palau USA, Div. of Soler & Palau Ventilation Group certifies that the Models TDB shown herein are licensed to bear the AMCA Seal. The ratings shown are based on test and procedures performed in accordance with AMCA Publication 211 and AMCA Publication 311 and comply with the requirement of the AMCA Certified Ratings Program.





SOUND CHARACTERISTICS

Size 12

RPM	Sound Performance Sones / LwA (Inches w.g.)				
	0	0.125	0.25	0.375	0.5
1550	18.1 / 80	16.3 / 78	-	-	-
1600	18.9 / 80	17.1 / 79	15.7 / 78	-	-
1650	19.8 / 81	18.1 / 80	16.7 / 79	-	-
1700	21 / 82	19 / 81	17.6 / 80	-	-
1725	21 / 83	19.5 / 81	18.1 / 80	-	-
1775	22 / 83	20 / 82	19.1 / 82	-	-
1825	23 / 85	22 / 83	20 / 83	-	-
1875	24 / 86	23 / 85	21 / 84	-	-
1925	25 / 87	24 / 86	23 / 85	22 / 84	-
2000	28 / 88	26 / 87	25 / 86	24 / 85	-
2075	30 / 90	29 / 89	27 / 88	26 / 87	-
2150	33 / 91	32 / 90	30 / 89	29 / 89	-
2200	35 / 92	34 / 91	32 / 90	30 / 90	-
2275	39 / 94	37 / 93	35 / 92	33 / 91	32 / 90
2350	43 / 96	40 / 95	38 / 94	36 / 93	35 / 92
2425	47 / 97	44 / 96	42 / 95	40 / 94	38 / 93

Size 16

RPM	Sound Performance Sones / LwA (Inches w.g.)									
	0	0.125	0.25	0.375	0.5	0.625	0.75	0.875	1	1.25
1100	13.7 / 75	12.3 / 73	10.8 / 72	-	-	-	-	-	-	-
1175	16.1 / 77	14.7 / 76	13.3 / 74	-	-	-	-	-	-	-
1225	17.8 / 79	16.4 / 78	15 / 76	13.7 / 75	-	-	-	-	-	-
1275	19.7 / 81	18.1 / 79	16.8 / 78	15 / 76	-	-	-	-	-	-
1300	21 / 82	19.1 / 80	17.7 / 79	15.8 / 77	-	-	-	-	-	-
1350	23 / 83	21 / 82	19.6 / 81	17.8 / 79	16.7 / 79	-	-	-	-	-
1375	24 / 84	22 / 83	21 / 82	18.7 / 80	17.4 / 79	-	-	-	-	-
1425	27 / 86	25 / 85	23 / 83	21 / 82	19 / 80	-	-	-	-	-
1475	29 / 88	27 / 86	26 / 85	23 / 84	21 / 82	19.8 / 81	-	-	-	-
1525	32 / 89	30 / 88	28 / 86	26 / 85	23 / 83	21 / 82	-	-	-	-
1575	33 / 90	31 / 88	29 / 87	27 / 86	25 / 84	23 / 83	22 / 83	-	-	-
1625	35 / 90	32 / 89	31 / 88	29 / 87	26 / 86	24 / 84	23 / 84	-	-	-
1675	36 / 91	34 / 90	32 / 89	30 / 88	28 / 87	26 / 85	24 / 85	23 / 85	-	-
1750	38 / 92	36 / 91	34 / 90	33 / 89	31 / 88	28 / 87	26 / 86	25 / 86	-	-
1825	41 / 93	39 / 92	37 / 91	35 / 90	33 / 90	31 / 88	29 / 87	27 / 87	27 / 87	-
1875	42 / 93	40 / 92	38 / 92	36 / 91	35 / 90	32 / 89	30 / 88	29 / 88	28 / 88	-
1925	43 / 94	41 / 93	39 / 92	37 / 92	36 / 91	34 / 90	32 / 89	30 / 88	29 / 89	-
1975	44 / 94	42 / 94	40 / 93	39 / 92	37 / 92	36 / 91	34 / 90	32 / 89	31 / 89	31 / 90
2025	45 / 95	43 / 94	41 / 94	40 / 93	39 / 93	37 / 92	35 / 91	33 / 90	32 / 90	32 / 91
2075	46 / 96	44 / 95	43 / 94	41 / 94	40 / 93	39 / 93	37 / 92	35 / 91	33 / 91	33 / 91

The sound ratings shown are loudness values in fan sones at 1.5 m (5 ft) in a hemispherical free field calculated per AMCA International Standard 301. Values shown are for: Installation Type A: free inlet hemispherical sone levels.



Soler & Palau USA, Div. of Soler & Palau Ventilation Group certifies that the Models TDB shown herein are licensed to bear the AMCA Seal. The ratings shown are based on test and procedures performed in accordance with AMCA Publication 211 and AMCA Publication 311 and comply with the requirement of the AMCA Certified Ratings Program.



Size 18

RPM	Sound Performance Sones / LwA (Inches w.g.)								
	0	0.125	0.25	0.375	0.5	0.625	0.75	0.875	1
1000	11.4 / 72	11 / 70	-	-	-	-	-	-	-
1050	12.3 / 73	11.9 / 72	12.1 / 72	-	-	-	-	-	-
1100	13.2 / 74	12.7 / 73	12.7 / 73	-	-	-	-	-	-
1125	13.7 / 75	13.2 / 74	13 / 73	-	-	-	-	-	-
1150	14.1 / 75	13.7 / 74	13.4 / 74	-	-	-	-	-	-
1200	15.1 / 77	14.6 / 75	14.2 / 74	15.2 / 77	-	-	-	-	-
1225	15.6 / 77	15.1 / 76	14.7 / 75	15.6 / 77	-	-	-	-	-
1275	16.7 / 78	16.2 / 77	15.8 / 76	16.3 / 78	-	-	-	-	-
1300	17.3 / 79	16.7 / 78	16.3 / 77	16.6 / 78	-	-	-	-	-
1350	18.4 / 80	17.9 / 79	17.3 / 78	17.4 / 78	-	-	-	-	-
1400	19.6 / 81	19.1 / 80.	18.6 / 79	18.2 / 79	19 / 81	-	-	-	-
1450	21 / 82	20 / 81	19.9 / 80	19.5 / 80	19.7 / 81	-	-	-	-
1500	22 / 83	22 / 82	21 / 82	21 / 81	20 / 82	21 / 83	-	-	-
1550	23 / 84	23 / 83	22 / 82	22 / 82	21 / 82	22 / 84	-	-	-
1600	24 / 85	24 / 84	23 / 83	23 / 83	22 / 83	23 / 84	-	-	-
1650	25 / 85	25 / 85	24 / 84	24 / 83	23 / 83	23 / 84	25 / 86	-	-
1675	25 / 86	25 / 85	25 / 85	24 / 84	24 / 83	24 / 85	25 / 86	-	-
1725	26 / 87	26 / 86	26 / 85	25 / 85	25 / 84	24 / 85	26 / 87	-	-
1775	27 / 87	27 / 87	27 / 86	26 / 86	26 / 85	25 / 85	26 / 87	28 / 88	-
1825	28 / 88	28 / 88	28 / 87	27 / 86	27 / 86	26 / 86	27 / 87	29 / 89	-
1850	29 / 88	29 / 88	28 / 87	28 / 87	27 / 86	27 / 86	27 / 87	29 / 89	-
1925	31 / 90	30 / 89	30 / 89	29 / 88	29 / 88	29 / 87	28 / 88	30 / 89	31 / 90
2000	33 / 91	32 / 90	32 / 90	31 / 89	30 / 89	30 / 88	30 / 88	31 / 89	33 / 91
2075	35 / 92	35 / 91	34 / 91	33 / 91	32 / 90	32 / 90	32 / 89.	32 / 90	34 / 91

The sound ratings shown are loudness values in fan sones at 1.5 m (5 ft) in a hemispherical free field calculated per AMCA International Standard 301. Values shown are for: Installation Type A: free inlet hemispherical sone levels.



Soler & Palau USA, Div. of Soler & Palau Ventilation Group certifies that the Models TDB shown herein are licensed to bear the AMCA Seal. The ratings shown are based on test and procedures performed in accordance with AMCA Publication 211 and AMCA Publication 311 and comply with the requirement of the AMCA Certified Ratings Program.



Size 20

RPM	Sound Performance Sones / LwA (Inches w.g.)									
	0	0.125	0.25	0.375	0.5	0.625	0.75	0.875	1	1.125
1050	13.6 / 76	12.8 / 75	-	-	-	-	-	-	-	-
1100	14.9 / 77	14.2 / 77	-	-	-	-	-	-	-	-
1125	15.6 / 78	14.9 / 77	13.9 / 77	-	-	-	-	-	-	-
1150	16.2 / 79	15.6 / 78	14.7 / 77	-	-	-	-	-	-	-
1175	16.9 / 79	16.2 / 79	15.4 / 78	-	-	-	-	-	-	-
1225	18.2 / 81	17.6 / 80	16.9 / 79	-	-	-	-	-	-	-
1275	19.7 / 82	19 / 81	18.3 / 81	17.4 / 80	-	-	-	-	-	-
1300	20 / 82	19.8 / 82	19 / 81	18 / 81	-	-	-	-	-	-
1325	21 / 83	21 / 83	19.8 / 82	18.7 / 81	-	-	-	-	-	-
1375	23 / 84	22 / 84	21 / 83	20 / 83	19.9 / 83	-	-	-	-	-
1400	24 / 85	23 / 84	22 / 84	21 / 83	21 / 83	-	-	-	-	-
1450	25 / 86	25 / 85	24 / 85	23 / 84	22 / 84	-	-	-	-	-
1525	28 / 87	27 / 87	26 / 86	25 / 86	24 / 85	-	-	-	-	-
1575	29 / 88	28 / 88	27 / 87	27 / 87	26 / 86	25 / 86	-	-	-	-
1625	30 / 89	30 / 89	29 / 88	28 / 88	27 / 87	26 / 87	-	-	-	-
1675	32 / 90	31 / 90	30 / 89	29 / 89	28 / 88	27 / 88	27 / 88	-	-	-
1700	32 / 90	32 / 90	31 / 90	30 / 89	29 / 89	28 / 88	28 / 88	-	-	-
1775	34 / 91	34 / 91	33 / 91	32 / 90	31 / 90	30 / 90	29 / 89	30 / 90	-	-
1850	36 / 93	36 / 92	35 / 92	34 / 92	34 / 91	33 / 91	31 / 91	31 / 91	-	-
1925	39 / 94	38 / 94	37 / 93	37 / 93	36 / 93	35 / 92	34 / 92	33 / 92	34 / 92	-
1950	40 / 94	39 / 94	38 / 94	38 / 93	37 / 93	36 / 93	35 / 92	34 / 92	35 / 92	-
2000	42 / 95	41 / 95	40 / 94	40 / 94	39 / 94	38 / 94	37 / 93	36 / 93	36 / 93	-
2050	44 / 96	43 / 96	42 / 95	42 / 95	41 / 95	40 / 94	39 / 94	38 / 94	38 / 94	38 / 94
2075	45 / 96	44 / 96	43 / 96	43 / 95	42 / 95	41 / 95	40 / 95	39 / 94	38 / 94	39 / 94

The sound ratings shown are loudness values in fan sones at 1.5 m (5 ft) in a hemispherical free field calculated per AMCA International Standard 301. Values shown are for: Installation Type A: free inlet hemispherical sone levels.



Soler & Palau USA, Div. of Soler & Palau Ventilation Group certifies that the Models TDB shown herein are licensed to bear the AMCA Seal. The ratings shown are based on test and procedures performed in accordance with AMCA Publication 211 and AMCA Publication 311 and comply with the requirement of the AMCA Certified Ratings Program.



Size 24

RPM	Sound Performance Sones / LwA (Inches w.g.)								
	0	0.125	0.25	0.375	0.5	0.625	0.75	0.875	1
800	12.8 / 75	11.9 / 74	-	-	-	-	-	-	-
850	14.3 / 77	13.4 / 76	12.6 / 75	-	-	-	-	-	-
900	15.8 / 78	14.9 / 77	14 / 77	-	-	-	-	-	-
950	17.3 / 80	16.5 / 79	15.5 / 78	-	-	-	-	-	-
975	18.1 / 81	17.3 / 80	16.3 / 79	16.1 / 79	-	-	-	-	-
1025	19.6 / 82	18.8 / 81	18 / 81	17.6 / 80	-	-	-	-	-
1075	21 / 84	21 / 83	19.7 / 82	19.1 / 82	-	-	-	-	-
1125	23 / 85	22 / 84	22 / 84	21 / 83	21 / 83	-	-	-	-
1150	24 / 86	23 / 85	23 / 84	22 / 84	22 / 84	-	-	-	-
1200	26 / 87	25 / 86	25 / 86	24 / 85	23 / 85	-	-	-	-
1225	27 / 88	26 / 87	26 / 86	25 / 86	24 / 85	-	-	-	-
1250	28 / 88	28 / 88	27 / 87	26 / 86	25 / 86	25 / 86	-	-	-
1275	29 / 89	29 / 88	28 / 88	27 / 87	26 / 87	26 / 87	-	-	-
1325	32 / 90	31 / 90	30 / 89	29 / 88	28 / 88	28 / 88	-	-	-
1375	34 / 91	33 / 91	32 / 90	31 / 90	30 / 89	30 / 89	-	-	-
1425	36 / 92	35 / 92	34 / 91	33 / 91	32 / 90	31 / 90	31 / 90	-	-
1450	37 / 93	36 / 92	35 / 92	34 / 91	33 / 91	32 / 90	32 / 90	-	-
1500	39 / 94	38 / 93	37 / 93	36 / 92	35 / 92	34 / 91	34 / 91	34 / 91	-
1525	40 / 94	39 / 94	38 / 93	37 / 93	36 / 92	35 / 92	35 / 92	35 / 92	-
1550	41 / 94	41 / 94	40 / 94	38 / 93	37 / 93	36 / 92	36 / 92	36 / 92	-
1625	45 / 96	44 / 96	43 / 95	42 / 95	41 / 94	40 / 94	39 / 93	39 / 93	38 / 93
1675	47 / 97	47 / 97	46 / 96	44 / 96	43 / 95	42 / 95	41 / 94	41 / 94	41 / 94
1725	50 / 98	49 / 97	48 / 97	47 / 97	46 / 96	45 / 96	44 / 95	43 / 95	43 / 95
1775	52 / 98	52 / 98	51 / 98	50 / 98	49 / 97	48 / 97	46 / 96	45 / 96	45 / 96

The sound ratings shown are loudness values in fan sones at 1.5 m (5 ft) in a hemispherical free field calculated per AMCA International Standard 301. Values shown are for: Installation Type A: free inlet hemispherical sone levels.



Soler & Palau USA, Div. of Soler & Palau Ventilation Group certifies that the Models TDB shown herein are licensed to bear the AMCA Seal. The ratings shown are based on test and procedures performed in accordance with AMCA Publication 211 and AMCA Publication 311 and comply with the requirement of the AMCA Certified Ratings Program.



Size 30

RPM	Sound Performance Sones / LwA (Inches w.g.)									
	0	0.125	0.25	0.375	0.5	0.625	0.75	0.875	1	1.25
600	11.8 / 73	10.1 / 71	-	-	-	-	-	-	-	-
650	13.5 / 75	12 / 74	-	-	-	-	-	-	-	-
700	15.2 / 77	13.9 / 76	12.8 / 75	-	-	-	-	-	-	-
750	16.9 / 79	15.9 / 78	14.8 / 77	-	-	-	-	-	-	-
775	17.8 / 80	16.9 / 79	15.8 / 78	-	-	-	-	-	-	-
800	18.6 / 81	17.8 / 80	16.8 / 79	-	-	-	-	-	-	-
825	19.6 / 82	18.8 / 81	17.8 / 80	-	-	-	-	-	-	-
850	21 / 83	19.7 / 82	18.8 / 81	18.1 / 80	-	-	-	-	-	-
875	22 / 84	21 / 83	19.8 / 82	19.1 / 81	-	-	-	-	-	-
900	23 / 85	22 / 84	21 / 83	20 / 82	-	-	-	-	-	-
925	24 / 86	23 / 85	22 / 84	21 / 83	-	-	-	-	-	-
950	25 / 87	24 / 86	23 / 85	22 / 84	22 / 83	-	-	-	-	-
975	27 / 87	26 / 87	24 / 85	23 / 84	23 / 84	-	-	-	-	-
1025	29 / 89	28 / 88	27 / 87	26 / 86	25 / 86	-	-	-	-	-
1075	32 / 90	31 / 90	29 / 89	28 / 88	27 / 87	-	-	-	-	-
1100	34 / 91	33 / 91	31 / 89	29 / 89	29 / 88	28 / 88	-	-	-	-
1125	35 / 92	34 / 91	32 / 90	31 / 89	30 / 89	29 / 88	-	-	-	-
1150	37 / 93	36 / 92	34 / 91	32 / 90	31 / 89	30 / 89	-	-	-	-
1175	38 / 93	37 / 93	35 / 92	34 / 91	32 / 90	31 / 90	-	-	-	-
1200	39 / 94	38 / 93	37 / 92	35 / 91	33 / 91	32 / 90	32 / 90	-	-	-
1225	41 / 94	40 / 94	38 / 93	36 / 92	35 / 91	34 / 91	33 / 91	-	-	-
1275	43 / 95	42 / 95	41 / 94	39 / 93	38 / 93	36 / 92	36 / 92	-	-	-
1325	46 / 96	45 / 96	44 / 95	42 / 95	41 / 94	39 / 93	38 / 93	38 / 93	-	-
1375	49 / 97	48 / 97	47 / 96	45 / 96	44 / 95	42 / 95	41 / 94	41 / 94	-	-
1400	50 / 98	50 / 98	48 / 97	47 / 96	45 / 96	44 / 95	43 / 95	42 / 9	-	-
1475	55 / 99	54 / 99	53 / 99	51 / 98	50 / 98	49 / 97	48 / 97	46 / 96	46 / 96	-
1550	59 / 101	59 / 101	58 / 100	57 / 100	55 / 99	54 / 99	53 / 98	52 / 98	51 / 97	-
1600	63 / 101	63 / 101	61 / 101	60 / 101	59 / 100	58 / 100	56 / 99	55 / 99	54 / 98	53 / 98

The sound ratings shown are loudness values in fan sones at 1.5 m (5 ft) in a hemispherical free field calculated per AMCA International Standard 301. Values shown are for: Installation Type A: free inlet hemispherical sone levels.



Soler & Palau USA, Div. of Soler & Palau Ventilation Group certifies that the Models TDB shown herein are licensed to bear the AMCA Seal. The ratings shown are based on test and procedures performed in accordance with AMCA Publication 211 and AMCA Publication 311 and comply with the requirement of the AMCA Certified Ratings Program.



Size 34

RPM	Sound Performance Sones / LwA (Inches w.g.)										
	0	0.125	0.25	0.375	0.5	0.625	0.75	0.875	1	1.25	1.5
600	15.1 / 78	15.4 / 78	-	-	-	-	-	-	-	-	-
625	16.2 / 79	16.4 / 79	-	-	-	-	-	-	-	-	-
650	17.4 / 80	17.5 / 80	17.8 / 81	-	-	-	-	-	-	-	-
675	18.5 / 81	18.6 / 81	19 / 82	-	-	-	-	-	-	-	-
700	19.7 / 82	19.7 / 82	20 / 83	-	-	-	-	-	-	-	-
725	21 / 83	21 / 83	22 / 84	21 / 84	-	-	-	-	-	-	-
750	22 / 84	22 / 84	23 / 85	23 / 85	-	-	-	-	-	-	-
775	23 / 85	24 / 85	24 / 86	25 / 86	-	-	-	-	-	-	-
800	25 / 86	25 / 86	25 / 87	26 / 87	-	-	-	-	-	-	-
825	26 / 87	26 / 87	27 / 87	27 / 88	27 / 87	-	-	-	-	-	-
850	28 / 88	28 / 88	28 / 88	29 / 89	29 / 89	-	-	-	-	-	-
875	29 / 89	29 / 89	30 / 89	31 / 90	31 / 90	-	-	-	-	-	-
900	30 / 89	31 / 90	31 / 90	32 / 90	33 / 91	31 / 90	-	-	-	-	-
925	32 / 90	32 / 90	33 / 91	34 / 91	34 / 91	33 / 91	-	-	-	-	-
950	33 / 91	34 / 91	34 / 91	35 / 92	36 / 92	35 / 92	33 / 91	-	-	-	-
975	35 / 92	35 / 92	36 / 92	36 / 92	37 / 93	37 / 93	35 / 92	-	-	-	-
1025	38 / 93	38 / 93	38 / 93	39 / 93	39 / 94	40 / 94	39 / 94	37 / 93	-	-	-
1050	39 / 94	39 / 94	40 / 94	40 / 94	41 / 94	41 / 95	41 / 95	39 / 94	-	-	-
1100	43 / 95	43 / 95	43 / 95	43 / 95	44 / 96	44 / 96	44 / 96	43 / 95	-	-	-
1125	44 / 96	44 / 96	45 / 96	45 / 96	45 / 96	45 / 96	46 / 96	45 / 96	43 / 95	-	-
1175	48 / 97	48 / 97	48 / 97	48 / 97	48 / 97	48 / 97	49 / 98	49 / 98	47 / 97	-	-
1225	51 / 98	51 / 98	52 / 98	52 / 98	52 / 98	52 / 98	52 / 99	52 / 99	52 / 99	-	-
1275	55 / 99	55 / 99	55 / 99	55 / 99	55 / 99	55 / 100	55 / 100	55 / 100	56 / 100	-	-
1325	60 / 100	60 / 100	60 / 100	60 / 100	59 / 100	59 / 101	59 / 101	59 / 101	59 / 101	58 / 101	-
1375	64 / 101	64 / 101	64 / 101	64 / 101	64 / 102	64 / 102	63 / 102	64 / 102	64 / 102	64 / 102	-
1425	69 / 102	69 / 102	69 / 102	68 / 102	68 / 103	68 / 103	68 / 103	68 / 103	69 / 103	70 / 103	-
1475	74 / 103	74 / 103	73 / 103	73 / 103	73 / 103	72 / 104	73 / 104	73 / 104	74 / 104	75 / 104	74 / 104
1525	79 / 104	79 / 104	78 / 104	78 / 104	78 / 104	77 / 105	78 / 105	78 / 105	79 / 105	80 / 105	81 / 105

The sound ratings shown are loudness values in fan sones at 1.5 m (5 ft) in a hemispherical free field calculated per AMCA International Standard 301. Values shown are for: Installation Type A: free inlet hemispherical sone levels.



Soler & Palau USA, Div. of Soler & Palau Ventilation Group certifies that the Models TDB shown herein are licensed to bear the AMCA Seal. The ratings shown are based on test and procedures performed in accordance with AMCA Publication 211 and AMCA Publication 311 and comply with the requirement of the AMCA Certified Ratings Program.



Size 36

RPM	Sound Performance Sones / LwA (Inches w.g.)										
	0	0.125	0.25	0.375	0.5	0.625	0.75	0.875	1	1.25	1.5
650	18.3 / 80	17.2 / 80	-	-	-	-	-	-	-	-	-
675	19.5 / 81	18.3 / 81	17.6 / 81	-	-	-	-	-	-	-	-
700	21 / 82	19.5 / 82	18.7 / 82	-	-	-	-	-	-	-	-
725	22 / 83	21 / 83	19.8 / 83	-	-	-	-	-	-	-	-
750	23 / 84	22 / 84	21 / 83	21 / 84	-	-	-	-	-	-	-
775	24 / 85	23 / 85	22 / 84	22 / 84	-	-	-	-	-	-	-
800	26 / 86	25 / 86	23 / 85	23 / 85	-	-	-	-	-	-	-
825	27 / 87	26 / 87	25 / 86	24 / 86	24 / 86	-	-	-	-	-	-
875	30 / 89	29 / 89	27 / 88	27 / 88	26 / 88	-	-	-	-	-	-
900	32 / 90	30 / 90	29 / 89	28 / 89	28 / 89	-	-	-	-	-	-
925	33 / 91	32 / 90	31 / 90	30 / 89	29 / 89	-	-	-	-	-	-
950	35 / 92	34 / 91	32 / 91	31 / 90	31 / 90	30 / 90	-	-	-	-	-
975	36 / 92	35 / 92	34 / 91	33 / 91	32 / 91	32 / 91	-	-	-	-	-
1000	38 / 93	37 / 93	36 / 92	35 / 92	34 / 92	33 / 92	-	-	-	-	-
1025	40 / 94	39 / 94	38 / 93	36 / 93	36 / 92	35 / 92	35 / 92	-	-	-	-
1050	42 / 95	41 / 94	40 / 94	38 / 93	37 / 93	36 / 93	36 / 93	36 / 93	-	-	-
1100	45 / 96	44 / 96	43 / 95	42 / 95	41 / 94	40 / 94	39 / 94	39 / 94	-	-	-
1125	47 / 97	46 / 96	45 / 96	44 / 95	42 / 95	41 / 95	41 / 95	40 / 95	-	-	-
1150	49 / 97	48 / 97	47 / 96	45 / 96	44 / 96	43 / 96	42 / 96	42 / 96	-	-	-
1175	51 / 98	50 / 98	49 / 97	47 / 97	46 / 96	45 / 96	44 / 96	44 / 96	43 / 96	-	-
1225	55 / 99	54 / 99	53 / 98	51 / 98	50 / 98	49 / 97	48 / 97	47 / 97	47 / 97	-	-
1275	59 / 100	58 / 100	57 / 100	55 / 99	54 / 99	52 / 99	52 / 98	51 / 98	50 / 98	51 / 99	-
1350	66 / 102	65 / 102	63 / 101	62 / 101	60 / 101	59 / 100	58 / 100	57 / 100	56 / 100	55 / 100	-
1400	70 / 103	70 / 103	68 / 102	66 / 102	65 / 102	63 / 101	62 / 101	61 / 101	60 / 101	59 / 101	-
1450	75 / 104	74 / 104	73 / 103	71 / 103	69 / 103	68 / 102	66 / 102	65 / 102	65 / 102	64 / 102	-
1500	80 / 105	79 / 105	78 / 104	76 / 104	74 / 104	73 / 104	71 / 103	70 / 103	69 / 103	68 / 103	67 / 103
1550	85 / 106	85 / 106	83 / 105	81 / 105	79 / 105	78 / 105	76 / 104	75 / 104	74 / 104	73 / 104	72 / 104
1600	90 / 107	90 / 107	88 / 106	87 / 106	85 / 106	83 / 106	81 / 105	80 / 105	78 / 105	77 / 105	76 / 105

The sound ratings shown are loudness values in fan sones at 1.5 m (5 ft) in a hemispherical free field calculated per AMCA International Standard 301. Values shown are for: Installation Type A: free inlet hemispherical sone levels.



Soler & Palau USA, Div. of Soler & Palau Ventilation Group certifies that the Models TDB shown herein are licensed to bear the AMCA Seal. The ratings shown are based on test and procedures performed in accordance with AMCA Publication 211 and AMCA Publication 311 and comply with the requirement of the AMCA Certified Ratings Program.



Size 42

RPM	Sound Performance Sones / LwA (Inches w.g.)										
	0	0.125	0.25	0.375	0.5	0.625	0.75	0.875	1	1.25	1.5
480	17 / 80	16.5 / 79	-	-	-	-	-	-	-	-	-
520	19.4 / 82	18.9 / 82	17.2 / 80	-	-	-	-	-	-	-	-
560	22 / 84	21 / 84	21 / 83	-	-	-	-	-	-	-	-
600	24 / 86	24 / 86	23 / 85	-	-	-	-	-	-	-	-
640	27 / 88	27 / 88	26 / 87	24 / 86	-	-	-	-	-	-	-
660	29 / 89	28 / 89	28 / 88	26 / 87	-	-	-	-	-	-	-
680	30 / 90	30 / 89	29 / 89	28 / 88	-	-	-	-	-	-	-
700	32 / 91	31 / 90	31 / 90	30 / 89	-	-	-	-	-	-	-
720	33 / 91	33 / 91	32 / 91	31 / 90	29 / 88	-	-	-	-	-	-
740	35 / 92	34 / 92	34 / 92	33 / 91	31 / 90	-	-	-	-	-	-
760	37 / 93	36 / 93	35 / 92	35 / 92	33 / 91	-	-	-	-	-	-
800	40 / 94	40 / 94	39 / 94	38 / 93	37 / 93	-	-	-	-	-	-
820	42 / 95	42 / 95	41 / 95	40 / 94	39 / 94	37 / 92	-	-	-	-	-
840	44 / 96	44 / 96	43 / 95	42 / 95	41 / 95	39 / 94	-	-	-	-	-
860	46 / 96	46 / 96	45 / 96	44 / 96	43 / 95	42 / 95	-	-	-	-	-
900	49 / 98	49 / 97	49 / 97	48 / 97	47 / 97	46 / 96	44 / 95	-	-	-	-
940	53 / 99	53 / 99	52 / 98	51 / 98	50 / 98	50 / 98	48 / 97	46 / 96	-	-	-
980	57 / 100	57 / 100	56 / 100	55 / 99	54 / 99	54 / 99	53 / 99	50 / 98	-	-	-
1020	61 / 101	61 / 101	60 / 101	59 / 100	59 / 100	58 / 100	57 / 100	55 / 99	-	-	-
1060	65 / 102	65 / 102	65 / 102	64 / 102	63 / 101	62 / 101	61 / 101	61 / 101	58 / 100	-	-
1100	70 / 103	70 / 103	69 / 103	68 / 103	68 / 102	67 / 102	66 / 102	65 / 102	64 / 101	-	-
1140	75 / 104	75 / 104	74 / 104	73 / 104	73 / 103	72 / 103	71 / 103	70 / 103	69 / 103	-	-
1180	80 / 105	80 / 105	79 / 105	79 / 105	78 / 104	77 / 104	76 / 104	75 / 104	74 / 104	-	-
1200	82 / 105	82 / 105	82 / 105	81 / 105	80 / 105	80 / 105	79 / 105	78 / 104	77 / 104	74 / 103	-
1240	88 / 106	88 / 106	87 / 106	86 / 106	86 / 106	85 / 106	84 / 106	83 / 105	82 / 105	80 / 105	-
1260	90 / 107	90 / 107	90 / 107	89 / 106	88 / 106	88 / 106	87 / 106	86 / 106	85 / 106	83 / 105	-
1300	96 / 107	96 / 107	96 / 107	95 / 107	94 / 107	93 / 107	93 / 107	92 / 107	91 / 107	89 / 106	86 / 106

The sound ratings shown are loudness values in fan sones at 1.5 m (5 ft) in a hemispherical free field calculated per AMCA International Standard 301. Values shown are for: Installation Type A: free inlet hemispherical sone levels.



Soler & Palau USA, Div. of Soler & Palau Ventilation Group certifies that the Models TDB shown herein are licensed to bear the AMCA Seal. The ratings shown are based on test and procedures performed in accordance with AMCA Publication 211 and AMCA Publication 311 and comply with the requirement of the AMCA Certified Ratings Program.



Size 48

RPM	Sound Performance Sones / LwA (Inches w.g.)										
	0	0.125	0.25	0.375	0.5	0.625	0.75	0.875	1	1.25	1.5
460	21 / 82	20 / 82	19.8 / 81	-	-	-	-	-	-	-	-
480	23 / 84	22 / 83	22 / 83	-	-	-	-	-	-	-	-
500	24 / 85	24 / 84	23 / 84	-	-	-	-	-	-	-	-
520	27 / 86	26 / 86	26 / 85	25 / 85	-	-	-	-	-	-	-
540	29 / 87	29 / 87	28 / 86	27 / 86	-	-	-	-	-	-	-
560	32 / 88	32 / 88	30 / 87	29 / 87	-	-	-	-	-	-	-
580	35 / 89	34 / 89	33 / 89	32 / 88	30 / 88	-	-	-	-	-	-
600	38 / 90	38 / 90	36 / 90	34 / 89	33 / 89	-	-	-	-	-	-
620	41 / 91	41 / 91	39 / 91	37 / 90	36 / 90	-	-	-	-	-	-
640	43 / 92	43 / 92	42 / 92	40 / 91	38 / 91	-	-	-	-	-	-
660	45 / 93	45 / 93	44 / 93	42 / 92	41 / 92	39 / 92	-	-	-	-	-
680	47 / 94	47 / 94	46 / 93	44 / 93	43 / 93	42 / 92	41 / 92	-	-	-	-
720	52 / 95	52 / 95	51 / 95	49 / 95	48 / 95	46 / 94	45 / 94	-	-	-	-
760	57 / 97	57 / 97	56 / 97	54 / 97	53 / 96	52 / 96	51 / 96	50 / 96	-	-	-
780	59 / 98	59 / 98	59 / 98	57 / 97	56 / 97	54 / 97	54 / 97	53 / 97	-	-	-
820	64 / 99	64 / 99	64 / 99	63 / 99	61 / 99	60 / 99	60 / 98	59 / 98	58 / 98	58 / 98	-
860	70 / 101	70 / 101	70 / 101	69 / 100	68 / 100	67 / 100	66 / 100	66 / 100	65 / 100	64 / 99	64 / 99
880	73 / 101	73 / 101	73 / 101	72 / 101	71 / 101	71 / 101	70 / 101	69 / 101	68 / 100	67 / 100	67 / 100
900	77 / 102	77 / 102	77 / 102	76 / 102	75 / 102	75 / 102	74 / 101	73 / 101	72 / 101	71 / 101	70 / 101
940	85 / 103	85 / 103	85 / 103	84 / 103	83 / 103	82 / 103	81 / 103	80 / 103	79 / 103	79 / 102	78 / 102
960	89 / 104	89 / 104	89 / 104	89 / 104	88 / 104	87 / 104	86 / 104	85 / 103	84 / 103	83 / 103	82 / 103
980	94 / 105	94 / 105	94 / 105	93 / 105	92 / 105	91 / 104	90 / 104	89 / 104	88 / 104	87 / 104	86 / 104
1000	99 / 105	99 / 105	99 / 105	98 / 105	97 / 105	96 / 105	94 / 105	93 / 105	92 / 105	91 / 104	90 / 104

The sound ratings shown are loudness values in fan sones at 1.5 m (5 ft) in a hemispherical free field calculated per AMCA International Standard 301. Values shown are for: Installation Type A: free inlet hemispherical sone levels.



Soler & Palau USA, Div. of Soler & Palau Ventilation Group certifies that the Models TDB shown herein are licensed to bear the AMCA Seal. The ratings shown are based on test and procedures performed in accordance with AMCA Publication 211 and AMCA Publication 311 and comply with the requirement of the AMCA Certified Ratings Program.



Size 54

RPM	Sound Performance Sones / LwA (Inches w.g.)										
	0	0.125	0.25	0.375	0.5	0.625	0.75	0.875	1	1.125	1.5
460	29 / 87	27 / 86	25 / 85	-	-	-	-	-	-	-	-
480	31 / 88	29 / 87	28 / 87	-	-	-	-	-	-	-	-
500	33 / 89	32 / 89	30 / 88	29 / 87	-	-	-	-	-	-	-
520	36 / 90	34 / 90	33 / 89	31 / 88	-	-	-	-	-	-	-
560	42 / 93	40 / 92	38 / 92	37 / 91	-	-	-	-	-	-	-
580	44 / 93	43 / 93	41 / 93	39 / 92	-	-	-	-	-	-	-
600	47 / 95	45 / 94	44 / 94	42 / 93	41 / 93	-	-	-	-	-	-
620	50 / 96	48 / 95	47 / 95	45 / 94	44 / 94	-	-	-	-	-	-
660	56 / 97	55 / 97	53 / 97	51 / 96	50 / 96	48 / 95	-	-	-	-	-
680	60 / 98	58 / 98	56 / 97	55 / 97	53 / 97	51 / 96	-	-	-	-	-
700	63 / 99	62 / 99	60 / 98	58 / 98	56 / 98	55 / 97	-	-	-	-	-
720	66 / 100	65 / 100	63 / 99	62 / 99	60 / 99	58 / 98	57 / 98	-	-	-	-
740	70 / 101	68 / 101	67 / 100	65 / 100	64 / 100	62 / 99	60 / 99	-	-	-	-
760	74 / 102	72 / 101	71 / 101	69 / 101	67 / 100	66 / 100	64 / 100	-	-	-	-
780	78 / 102	76 / 102	75 / 102	73 / 101	71 / 101	69 / 101	68 / 101	66 / 100	-	-	-
800	82 / 103	80 / 103	78 / 103	76 / 102	75 / 102	74 / 102	72 / 101	70 / 101	-	-	-
840	90 / 105	89 / 104	87 / 104	85 / 104	84 / 104	82 / 103	80 / 103	79 / 103	77 / 102	-	-
860	95 / 105	93 / 105	91 / 105	89 / 104	88 / 104	86 / 104	85 / 104	83 / 104	81 / 103	79 / 103	-
880	99 / 106	97 / 106	96 / 105	94 / 105	93 / 105	91 / 105	89 / 105	87 / 104	86 / 104	84 / 104	-
900	104 / 106	103 / 107	100 / 106	98 / 106	97 / 106	96 / 106	94 / 105	92 / 105	90 / 105	89 / 105	87 / 104

The sound ratings shown are loudness values in fan sones at 1.5 m (5 ft) in a hemispherical free field calculated per AMCA International Standard 301. Values shown are for: Installation Type A: free inlet hemispherical sone levels.



Soler & Palau USA, Div. of Soler & Palau Ventilation Group certifies that the Models TDB shown herein are licensed to bear the AMCA Seal. The ratings shown are based on test and procedures performed in accordance with AMCA Publication 211 and AMCA Publication 311 and comply with the requirement of the AMCA Certified Ratings Program.



Size 60

RPM	Sound Performance Sones / LwA (Inches w.g.)									
	0	0.125	0.25	0.375	0.5	0.625	0.75	0.875	1	1.125
520	34 / 89	30 / 87	29 / 87	32 / 87	-	-	-	-	-	-
540	37 / 90	33 / 89	31 / 88	34 / 88	-	-	-	-	-	-
560	40 / 91	36 / 90	33 / 89	36 / 89	38 / 89	-	-	-	-	-
580	43 / 92	39 / 91	36 / 90	39 / 90	41 / 90	-	-	-	-	-
600	46 / 93	42 / 92	39 / 91	41 / 91	44 / 91	45 / 91	-	-	-	-
620	49 / 94	46 / 93	42 / 92	43 / 92	47 / 92	48 / 92	-	-	-	-
640	53 / 95	49 / 94	45 / 93	45 / 93	49 / 93	52 / 93	-	-	-	-
660	57 / 96	53 / 95	49 / 94	48 / 93	52 / 94	56 / 94	-	-	-	-
680	60 / 96	56 / 96	53 / 95	50 / 94	54 / 95	59 / 95	60 / 95	-	-	-
700	64 / 97	60 / 97	56 / 96	53 / 95	57 / 95	62 / 96	64 / 96	-	-	-
720	69 / 98	64 / 97	60 / 97	57 / 96	59 / 96	64 / 97	69 / 97	69 / 97	-	-
740	72 / 99	68 / 98	64 / 98	60 / 97	62 / 97	67 / 97	73 / 98	74 / 98	-	-
760	75 / 100	71 / 99	67 / 98	64 / 98	63 / 98	69 / 98	75 / 98	78 / 99	78 / 99	-
780	78 / 101	74 / 100	71 / 99	67 / 99	65 / 98	70 / 99	76 / 99	81 / 99	81 / 99	-
800	82 / 101	78 / 101	74 / 100	70 / 99	67 / 99	72 / 99	77 / 100	83 / 100	85 / 100	-
820	85 / 102	81 / 101	77 / 101	74 / 100	71 / 100	74 / 100	79 / 100	85 / 101	89 / 101	-
840	89 / 103	85 / 102	81 / 102	77 / 101	74 / 100	76 / 100	80 / 101	86 / 101	92 / 102	92 / 102
860	93 / 103	89 / 103	85 / 102	81 / 102	78 / 101	77 / 101	82 / 101	88 / 102	94 / 102	96 / 102
880	96 / 104	92 / 104	89 / 103	85 / 103	81 / 102	80 / 102	84 / 102	89 / 102	96 / 103	100 / 103
900	100 / 105	96 / 104	92 / 104	89 / 103	85 / 103	82 / 102	86 / 103	91 / 103	97 / 103	104 / 104

The sound ratings shown are loudness values in fan sones at 1.5 m (5 ft) in a hemispherical free field calculated per AMCA International Standard 301. Values shown are for: Installation Type A: free inlet hemispherical sone levels.



Soler & Palau USA, Div. of Soler & Palau Ventilation Group certifies that the Models TDB shown herein are licensed to bear the AMCA Seal. The ratings shown are based on test and procedures performed in accordance with AMCA Publication 211 and AMCA Publication 311 and comply with the requirement of the AMCA Certified Ratings Program.



Limited Warranty

Soler & Palau USA and Soler & Palau Canada (Manufacturer) 6393 Powers Avenue, Jacksonville, Florida 32217 (USA), 5600 Ambler Drive, Mississauga, ON L4W 2K9 (Canada) warrants the Model TDB to be free from defects in design, materials and workmanship (exclusive of abrasion, corrosion or erosion) for two (2) years from the date of shipment to the original purchaser or the date of notification of readiness to ship. Motor warranty is one (1) year. In order to claim the benefit of this warranty, buyer must notify manufacturer in writing of the claimed defect within ten (10) days after discovering it and return this equipment or parts to the manufacturer with transportation prepaid. In the event of on-site repair, no service technician will be dispatched until manufacturer receives your written purchase order. If any of the following conditions exist, the warranty will be null and void: (1) Buyer has permitted other persons not approved or authorized by manufacturer to alter, adjust, replace or repair the equipment or any part thereof. (2) Buyer has not followed instructions or other directions given in the contract documents or our maintenance manual. (3) When breakage or other loss or damage is the result of any negligence, misuse or fault on the part of any operator or other person not under our supervision or control. (4) The defect is the result of designs or drawings made, furnished or specified by others. (5) In the case of goods not manufactured but supplied by the manufacturer as part of a contract, manufacturer shall only be liable to the same extent that our supplier is to manufacturer, not to exceed any liability manufacturer would have for warranty on our own equipment. (6) Buyer has not paid in full invoices submitted to the buyer which are due for payment. (7) Unusual wear and tear of the equipment.

Statements relating to the product, its use or installation made prior to the execution of the agreement, are not warranties except to the extent that the contrary is expressly set forth herein. It is understood that such statements were not intended to, and did not, form a part of the agreement; they were merely made in the course of negotiations of the parties.

THIS WARRANTY IS IN LIEU OF ANY OTHER EXPRESSED OF IMPLIED WARRANTIES, INCLUDING ANY IMPLIED WARRANTY OF MERCHANTABILITY OR FITNESS FOR ANY PARTICULAR PURPOSE. OUR SOLE AND EXCLUSIVE OBLIGATION UNDER THIS WARRANTY IS TO REPAIR OR REPLACE DEFECTIVE EQUIPMENT OR PARTS OR, AT OUR OPTION, TO PAY THE REASONABLE COST OF REPAIR OR REPLACEMENT. BUYER AGREES THAT NO OTHER REMEDY (INCLUDING, BUT NOT LIMITED TO, INCIDENTAL OR CONSEQUENTIAL DAMAGES, DAMAGE FOR LOST PROFITS OR SALES, OR DAMAGES FOR INJURIES TO PERSON OR PROPERTY) SHALL BE AVAILABLE. NOTWITHSTANDING THE ABOVE, THE TOTAL AMOUNT THAT MAY IN ANY EVENT BE PAYABLE IN SETTLEMENT OR LIABILITY, HOWEVER INCURRED, SHALL NOT EXCEED THE CONTRACT PRICE.