

## DFD35 AND DFD35SS MULTIPLE BLADE "DYNAMIC" FIRE DAMPER

1½ HOUR RATING UL555 RATED  
FOR USE IN "DYNAMIC" OR "STATIC" SYSTEMS

### APPLICATION

The DFD35 and DFD35SS are 1½ hour rated multiple blade Dynamic (Fan On) fire dampers. The DFD35 is constructed with triple vee-groove blades from galvanized steel and DFD35SS, 304 or 316 stainless steel and can be installed vertically in walls or horizontally in masonry floors.

### STANDARD CONSTRUCTION

#### FRAME

DFD35 – 5" x 1" x 16 gage (127 x 25 x 1.52) galvanized steel hat channel, structurally superior to 13 gage (2.3) channel frame.

DFD35SS – 5" x 1" x 16 gage (127 x 25 x 1.52) galvanized steel hat channel.

#### BLADES

16 gage (1.52) galvanized, 304 or 316 stainless steel triple vee groove, approximately 6" (152) on center.

#### BEARINGS

Stainless steel sleeve, pressed into frame.

#### LINKAGE

Concealed in frame.

#### AXLES

½" (13) plated steel hex or 300 series stainless steel.

#### FUSIBLE LINK

165°F (74°C) standard. 212°F (100°C) available.

#### DAMPER WEIGHT

Approximately 8 lbs. per sq. ft. without damper sleeve.

### DAMPER SIZES

#### DFD35

#### MINIMUM SIZE

Vertical or Horizontal Installation – 8"w x 6"h (203 x 152).

#### MAXIMUM SIZE

Single Section

Vertical or Horizontal Installation – 36"w x 48"h (914 x 1219).

Multiple Section

Vertical or Horizontal Installation – 120"w x 48"h (3048 x 1219) or 72"w x 96"h (1829 x 2438).

#### DFD35SS

#### MINIMUM SIZE

Vertical or Horizontal Installation – 8"w x 6"h (203 x 152).

#### MAXIMUM SIZE

Single Section

Vertical or Horizontal Installation – 30"w x 48"h (762 x 1219).

Multiple Section

Vertical or Horizontal Installation – 90"w x 48"h (2286 x 1219).

#### NOTES:

1. Dimensions in inches, parentheses ( ) indicate millimeters.
2. Damper assembly furnished actual size.

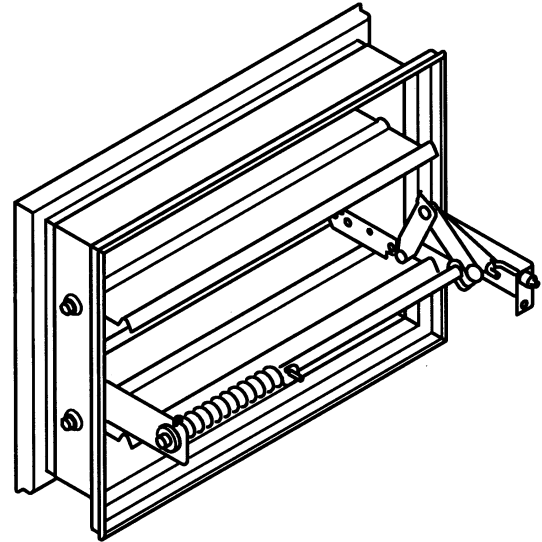

The DFD35 and DFD35SS dampers meet the requirements for fire dampers established by:

- National Fire Protection Association NFPA Standards 90A, 92A, 92B and 101
- ICC International Building Codes
- CSFM California State Fire Marshal Listing #3225-245:005



SEE COMPLETE  
MARKING  
ON PRODUCT

UL555 Classification R5531

### OPTIONS

- **FM Approved** as Specification Tested Product.
- **SP100 Switch Package** to remotely indicate damper blade position.
- **FAST Angle** for one side angle installation.
- **PFMA Angles** for two side angle installation.
- **Sleeve** of various lengths and gages to ensure field compliance with UL installation requirements.
- **Jamb Seals** stainless steel flexible metal compression type.
- **Blade Seals** silicone blade edge seal.
- **Crank Lever** to assist with testing and fuse link replacement.
- **GA, Grille Access** for one side installation and "out of wall" applications.
- **OW, Out of Wall** of application where the damper can not be installed within the plane of the wall or floor.

# AMCA LICENSED LEAKAGE AND AIR PERFORMANCE DATA



Ruskin Company certifies that the DFD35 and DFD35SS shown hereon are licensed to bear the AMCA Seal. The ratings shown are based on tests and procedures performed in accordance with AMCA Publication 511 and comply with the requirements of the AMCA Certified Ratings Program. The AMCA Certified Ratings Seal applies to air performance for the DFD35 and DFD35SS.

To determine the AMCA Licensed air performance:

Locate the applicable feet per minute face velocity on the bottom of the velocity vs. pressure drop chart below. Move up the chart to the most appropriate size damper line. From the intersection point, move left to determine the pressure drop on the left side of the chart.

**VELOCITY vs. PRESSURE DROP**

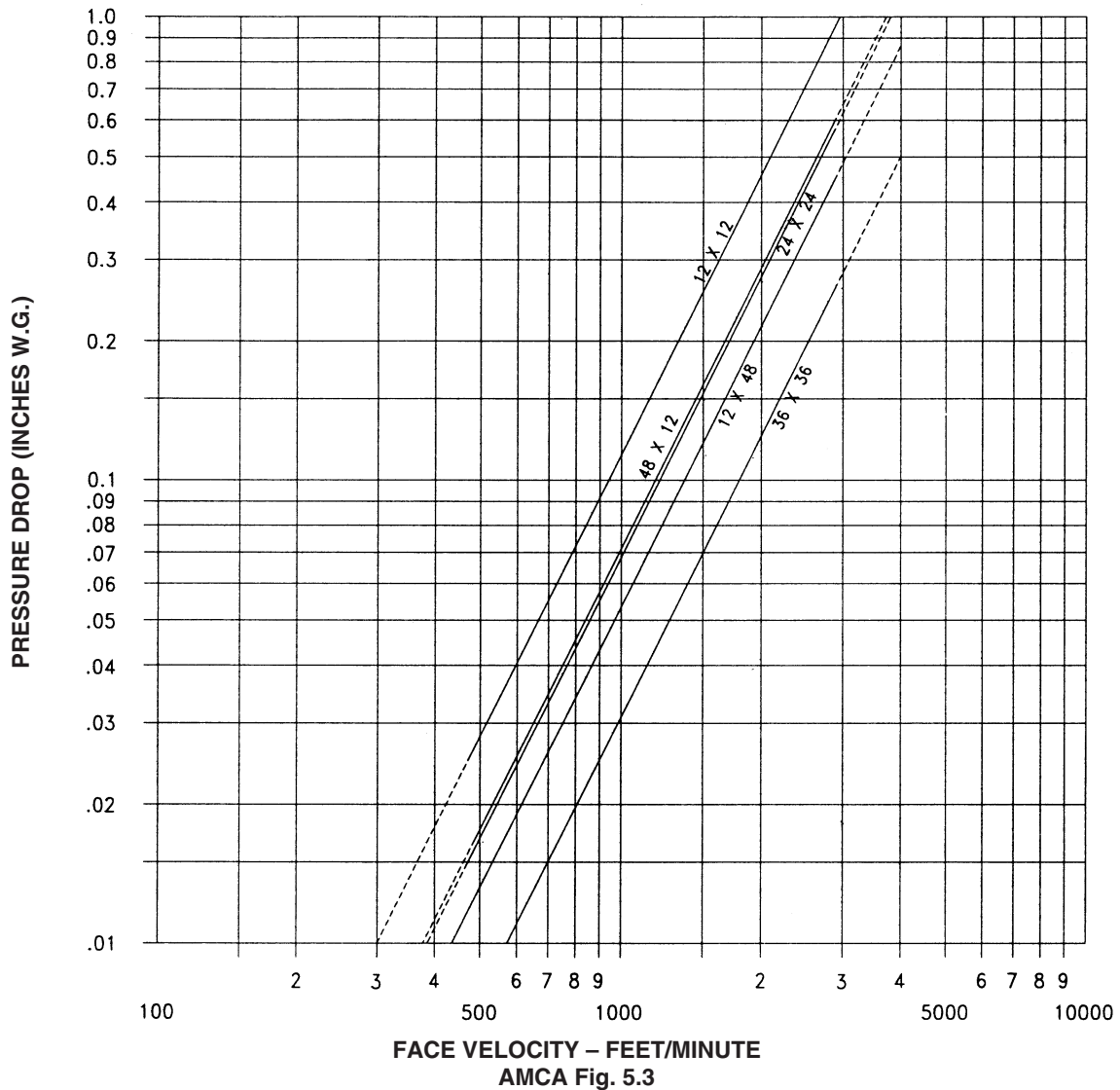

# DAMPER DIMENSIONAL DATA

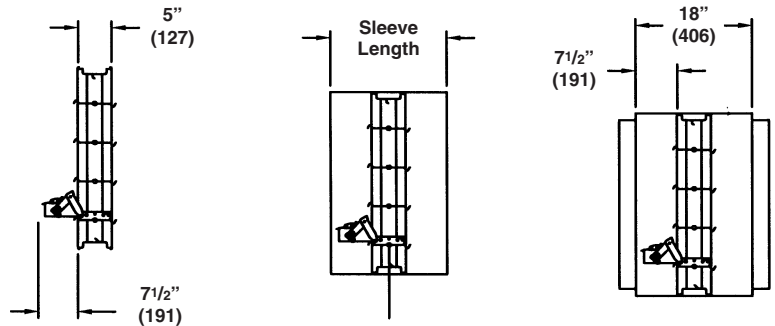

Sleeve Dimensions

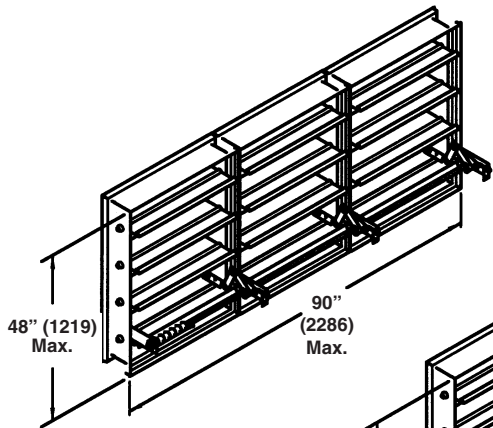

DFD35SS Multiple Section

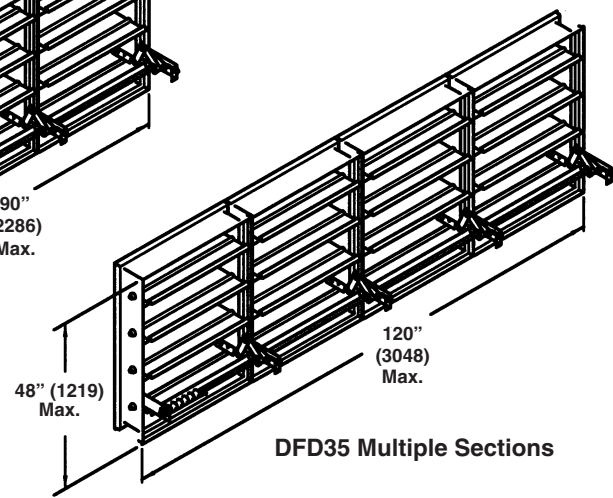

DFD35 Multiple Sections

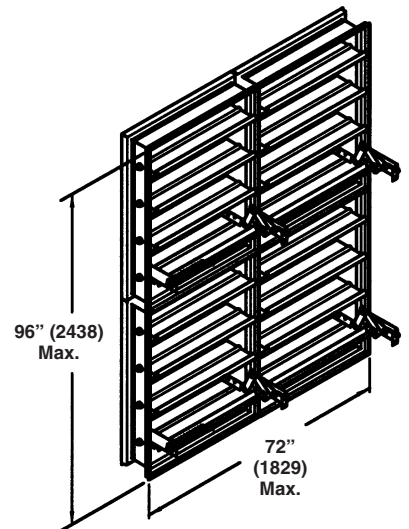

DFD35 Multiple Section

## FUSE LINK ADJUSTMENT

### To Test or Replace the Fuse Link

1. Loosen the nuts on the J-bolt (Do not remove the nuts all together).
2. Remove the truarc ring.
3. Turn the jackshaft to open the damper and remove the fuse link.
4. Cycle the damper full open to full close positions, making sure the damper operates freely.

**The damper should be able to spring closed in any position.**

5. Replace the fuse link and adjust the damper into the original position.

**Note:** The damper can be adjusted in any position for volume control operation.

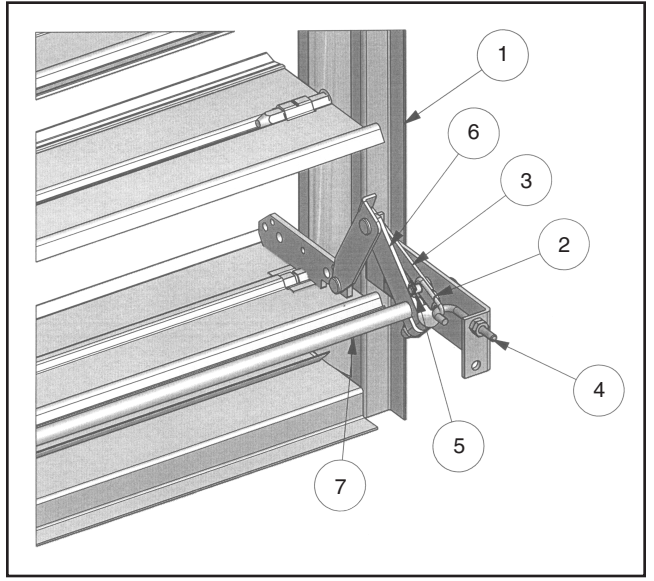

**CAUTION**

Damper assembly is under spring tension. Care should be taken to avoid bodily injury or damage to the damper assembly.

ITEM	DESCRIPTION
1.	Multiple Blade Fire Damper
2.	Fusible Link Issue 'E'
3.	Fuse Link Linkage
4.	J-Bolt
5.	Truarc Ring 1/4" (6)
6.	Over Center Linkage
7.	Jackshaft Assembly

# SLEEVE TRANSITION DIMENSIONAL INFORMATION

## DUCT TRANSITION CONNECTIONS

FD35 and FD35SS dampers may be supplied with Round, Oval and Rectangular duct connections.

Style	Description
B	Units Under 6" (152) Tall
R	Round Non-Sealed (Low Pressure)
CR	Round Sealed (Medium Pressure)
WR	Round Welded (High Pressure)
C	Rectangular Sealed (Low and Medium Pressure)
WC	Rectangular Welded (High Pressure)
LO	Oval Non-Sealed (Low Pressure)
CO	Oval Sealed (Medium Pressure)
WO	Oval Welded (High Pressure)

The square damper size will be 2" (51) larger in width and height than the round, oval or rectangular duct size ordered.

## MINIMUM and MAXIMUM SIZES

### Round Transitions

Minimum 6" (152) diameter  
 Maximum FD35 – 94" (2388) diameter  
 Maximum FD35SS – 46" (1168) diameter

### Rectangular and Oval Transitions

Minimum 6" w x 4" h (152 x 102) diameter  
 Maximum FD35 – 118" w x 94" (2997 x 2388)  
 Maximum FD35SS – 88" w x 46" (2235 x 1168)

### 'B' Style Transitions

Minimum height 4" (102) 'B' style transitions are utilized on units where the damper height is less than 6" (152).

Consult Ruskin for other available styles and sizes.

**Note:** For medium pressure units (Styles CR, C and CO) the collar extends 1 1/2" (38) beyond the sleeve length and for low pressure and high pressure units (Styles R, WR, WC and LO) the collar extends 2 1/2" (64) beyond the sleeve length.

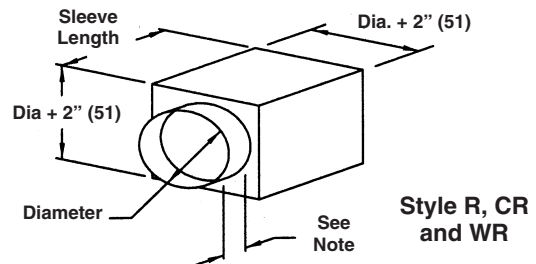
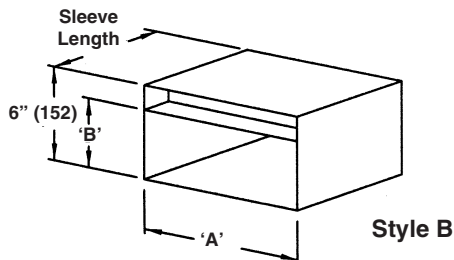
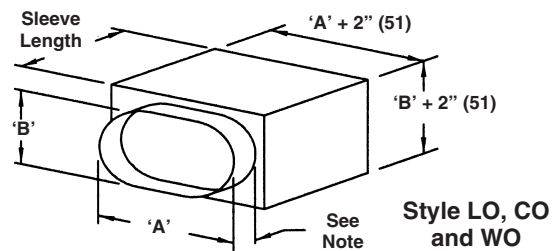
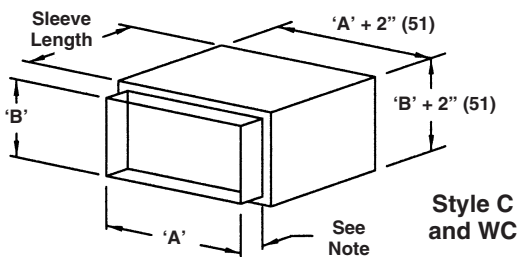

## SUGGESTED SPECIFICATION

Furnish and install at locations shown on plans or as described in schedules AMCA Certified fire dampers constructed and tested in accordance with UL Safety Standard 555 that meet or exceed the following specifications. Fire Dampers shall be produced in an ISO9001 certified factory.

Damper frame, where size permits, shall be constructed using UniFrame Design Concept (UDC) and shall be a minimum of 16 gage (1.52) galvanized steel formed into a structural hat channel superior to 13 gage (2.3) channel frame. Top and bottom frame members on dampers less than 13" (330) high shall be low profile design to maximize the free area of these smaller dampers. Damper blades shall be single skin 16 gage (1.52) galvanized steel (or stainless steel) with three longitudinal grooves for reinforcement. Bearings shall be stainless steel sleeve turning in an extruded hole in the frame for maximum life.

Each fire damper shall have a 1 1/2 hour fire protection rating and shall be supplied with a 165°F (74°C) or 212°F (100°C) fusible link. Fire dampers shall be approved for vertical or horizontal mounting as

required by the location shown and shall be installed using steel sleeves, angles and other materials and practice required to provide an installation in accordance with the damper manufacturer's installation instructions. Submittal information shall include the fire protection, maximum velocity and pressure ratings and the manufacturer's UL installation instructions. In addition, the fire dampers shall be AMCA licensed for air performance and shall bear the AMCA Certified Ratings Steel.

Each fire damper shall be labeled for use in dynamic systems. Static only damper labels are not permissible. The damper shall be rated for dynamic closure at 2000 fpm (10.2 m/s) and 4" w.g. (1 kPa) static pressure and shall be tested and rated to close with airflow in either direction.

Dynamic fire dampers shall be Ruskin multiple model DFD35 or DFD35SS.

(Consult [www.ruskin.com](http://www.ruskin.com) for electronic version of this "Quick" spec as well as for complete 3-part CSI MasterFormat Specifications)

# RUSKIN®

3900 Dr. Greaves Rd.  
 Kansas City, MO 64030  
 (816) 761-7476  
 FAX (816) 765-8955  
[www.ruskin.com](http://www.ruskin.com)

Printed on recycled paper  
 using vegetable based inks

