

CENTRIFUGAL FANS

Single Width, Single Inlet
WFS & WBS Series



WTC TECH CO., LTD.
367 Bangpoo Industrial Estate, Praekasa, Samutprakan 10280 Thailand
Tel: 02 709 6901-3 Fax: 02 709 6900
www.wtcfan.com
sales@wtcfan.com



WTC Centrifugal Fans & AMCA Certification



WTC Tech Co.,Ltd. certifies that the WFS and WBS series shown herein are licensed to bear the AMCA Seal. The ratings shown are based on tests and procedures performed in accordance with AMCA publication 211 and AMCA publication 311 and comply with the requirements of the AMCA Certified Ratings Program.





COMPANY PROFILE

Since 1993, WTC Tech Co., Ltd. was established as a joint venture company, between the shareholders from Europe and Thailand to manufacture industrial fans which has been a well recognized product, located at Bangpoo Industrial Estate, Samutprakan.

With the technology and knowledge transfer from experienced international engineers, we have been providing high-quality products that response to the customers demand throughout the last 17 years.

Over the past decade, we have developed and emphasized on reliable production process, quality control system and continuous development activities. With an emphasis on engineering knowledge as well as new technology, we have developed a lot of experienced and capable Thai engineers having charge of production

and quality control to manage the production activities to assure that the customers would acquire the standardized products and to be of assistance for any customers' inquiry.

With our quality policy, we have adopted & certified for ISO9001:2000 and AMCA sealed for Centrifugal Single Inlet Fans that will guarantee our quality commitment to deliver to all the customers.

WTC Tech Co., Ltd. as the experienced manufacturer proudly presents **w/tc**, the quality brand of industrial fans. With our high standard production and quality control process, we assure all customers that we will offer only quality products, competitive price, reliable delivery and professional service support for the customer's highest satisfaction.



	Page
Company Profile	4
Introduction	
General	7
Why ventilate?	7
Fan Engineering	7
Fan's Law	8
Materials and Construction	9
Conversion Factors	10
Serie WFS Technical Specifications	11
Serie WFS-O Dimensions & Weights	40
Serie WBS Technical Specifications	43
Serie WBS-O Dimensions & Weights	68

GENERAL

All dwellings need a supply of fresh air, not just for the health and comfort of the occupants, but also to control condensation, remove pollutants and to ensure the safe and efficient operation of some combustion appliances. The amount of fresh air should match the needs of the dwelling and the people living within it.

To achieve an energy efficient standard of ventilation requires consideration of both the building fabric and the efficiency of the ventilation system. Whether designs for new or existing buildings are under consideration, ventilation should be thought of as part of an integrated design approach for achieving energy efficiency.

The thermal insulation, heating systems and controls, and householder advice are some other important aspects to consider during the design process.

WHY VENTILATE ?

Ventilation is necessary to provide a healthy and comfortable internal environment for the building's occupants. The main task of ventilation is to remove polluted indoor air from a building and replace it with 'fresh' outside air.

Ventilation can also serve other roles—for instance, to provide an air supply to open-flued combustion appliances and to form part of an integrated strategy to provide thermal comfort and control summertime over-heating.

FAN ENGINEERING

Airflow

Airflow is most commonly expressed as a Volumetric Flow Rate. It can be considered as an amount of air that is moved. Typical units of measurement are:

m³/h (CMH): Cubic metres per hour
 CFM: cubic feet per minute
 L/s: litres per second

Resistance To Airflow

Air needs to be pushed or pulled to move it from one point to another. When moving any object, force is required to overcome the resistance to movement. Moving air requires a force to overcome the resistance through a duct or tube. The resistance to flow is due to the viscosity of air and the friction of each molecule passing over one another. Typical Units of measurement are:

mBar: millibar
 Pa: Pascals
 InWg: Inches Water Gauge
 mm.Aq.: millimetre Aqueous

Fan Performance

Fan performance is presented on a graph called a fan curve. Volume flow is on the X axis and pressure is on the Y axis. It shows how much volume of air is moved against resistance to flow, or pressure development of the fan. As you increase the resistance to flow, the volume output of the fan decreases.

System Resistance

The system be it a tube, black box or a room has a resistance to airflow, along it or through it. This resistance to airflow is expressed as a pressure. The value of this resistance to flow increases with increase in volume. The system resistance curve is a air volume to the power of two.

P is proportional to V²

For example twice the volume is 2² which = four time of pressure.

Half the volume 0.5² = 0.25 of the pressure.

This can be plotted on a fan curve and where the system with that fan fitted.

Noise

A fan is a good generator of noise! We hear noise by sensing pressure variation on our ear drums. When a fan operates the noise generated from various parts of the fan is transmitted by air molecules bouncing against each other and spreading out as small pressure waves.

Sound power and Sound pressure: Sound can be expressed in two ways. Sound power, how many watts of energy is converted into sound, or Sound pressure where the pressure of the sound waves are measured in Pascal's.

Decibels (dB): Both sound power and sound pressure are expressed in units of measurement called decibels. The measurements are on a logarithmic scale as the ear is sensitive to noise in a logarithmic fashion.

A Weighting sound pressure level (dBA): Noise figures are commonly expressed as A weighted. This is a method to provide a figure which gives a sound level which is perceived by the human ear.

FAN'S LAW

The most commonly used fan laws in simplified form are:

1. CFM varies directly with RPM.

$$\frac{CFM_1}{CFM_2} = \frac{RPM_1}{RPM_2}$$
2. SP varies with the square of the RPM.

$$\frac{SP_1}{SP_2} = \left(\frac{RPM_1}{RPM_2}\right)^2 = \left(\frac{CFM_1}{CFM_2}\right)^2$$
3. HP varies with the cube of the RPM.

$$\frac{HP_1}{HP_2} = \left(\frac{RPM_1}{RPM_2}\right)^3 = \left(\frac{CFM_1}{CFM_2}\right)^3$$

Which:

CFM = Fan Flow rate (F³/Min.)
 RPM = Speed of Rotation (rpm.)
 SP = Fan Static Pressure (in.wg.)
 HP = Fan Power In



Fan Casing :

The fan casings are made of galvanized sheet metal. Predrilled holes are provided for easy to installation located on the side plates to fix mounting frames. The casings are available for single inlet type.

Impeller :

The impellers forward curved are made of galvanized steel sheet. Backward curve impellers are made of aluminum. All the wheels are statically and dynamically balanced.

Inlet cone :

Inlet cones matched to the impeller reduce entry losses to minimum. Inlet cones are made of polyamide reinforced with fiberglass.

Shaft :

Fan shafts are steel turned, ground and polished to precise tolerances. All shaft is sized for critical speed of at least 125 percent of maximum operating speed.

Motor :

Motors are heavy duty type with permanently lubricated bearing Degree of protection is IP55 (Protection against water jets from any direction.)

Bearing :

Bearings are heavy duty regreasable ball type in a pillow block cast iron housing select for at least 20,000 working hours and low noise while working.

Fan Model Code :

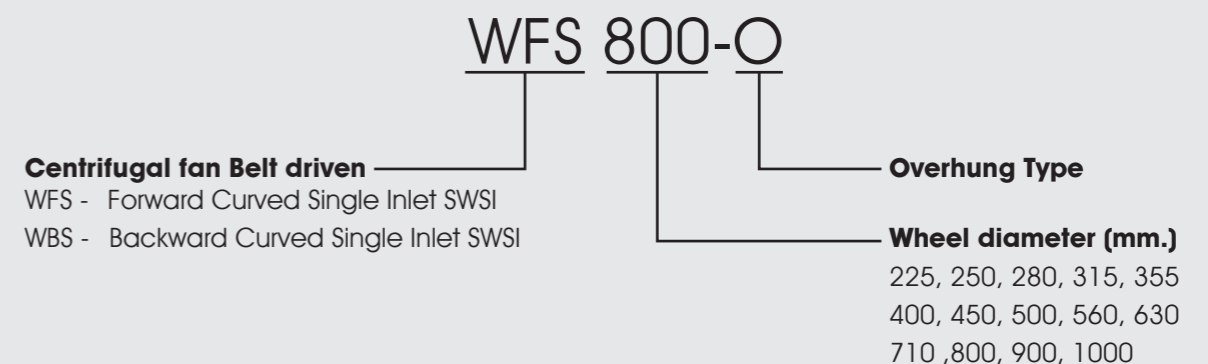

Conversion Factors

Length

Centimetres	x 0.3937	= Inches
Fathoms	x 6.0	= Feet
Feet	x 12.0	= Inches
Feet	x 0.3048	= Metres
Inches	x 2.54	= Centimetres
Kilometres	x 0.6214	= Miles
Metres	x 3.281	= Feet
Metres	x 39.37	= Inches
Metres	x 1.094	= Yards
Miles	x 5280.0	= Feet
Miles	x 1.609	= Kilometres
Rods	x 5.5	= Yards
Yards	x 0.9144	= Metres

Pressure

millibar	x 100	= Pascal
Pascal	x 4.02×10^3	= Inches water
Pascal	x 0.1021	= millimetre aqueous
Inches water gauge	x 25.4	= millimetre aqueous

Flow rate

Cubic metre per hour	x 0.5886	= Cubic feet per minute
Cubic metre per minute	x 35.315	= Cubic feet per minute
liters per second	x 2.1189	= Cubic feet per minute

Torque

Gram-centimetres	x 0.139	= Ounce-inches
Newton-metres	x 0.7376	= Pound-feet
Newton-metres	x 8.851	= Pound-inches

Volume

Cubic feet	x 0.283	= Cubic metres
Cubic feet	x 7.481	= Gallons
Cubic inches	x 0.5541	= Ounces (fluid)
Cubic metres	x 5.31	= Cubic feet
Cubic metres	x 1.308	= Cubic yards
Cubic yards	x 0.7646	= Cubic metres
Gallons	x 0.1337	= Cubic feet
Gallons	x 3.785	= Liters

Force and Weight

Kilograms	x 2.205	= Pounds
Newtons	x 0.2248	= Pounds (force)
Ounces	x 28.35	= Grams
Pounds	x 453.6	= Grams
Tons (short)	x 907.2	= Kilograms
Tons (short)	x 2000	= Pounds

Energy or Work

Btu	x 778.2	= Foot-Pounds
Btu	x 252.0	= Gram-calories

Power

Btu per hour	x 0.293	= Watts
Horsepower per second	x 550.0	= Foot-pounds
Horsepower	x 746.0	= Watts

Plane angle

Degrees	x 0.0175	= Radians
Minutes	x 0.01667	= Degrees
Minutes	x 2.9×10^{-4}	= Radians
Quadrants	x 90.0	= Degrees
Quadrants	x 1.5708	= Radians

* Pounds are U.S. avoirdupois.

* Gallons and quarts are U.S.



Forward Curved Single Inlet SWSI

WFS 225-1000

*Overhung Type Centrifugal Fan Curves are as same as those of the standard Centrifugal



WFS 225

Forward Curved Single Inlet SWSI



Wheel Diameter 225 mm.
Outlet Area 0.0412 m²
Material Casing: Galvanised Steel
 Impeller: Galvanised Steel
 Inlet Cone: Polyamide FRP
Rotation Forward

Motor (kW)	0.37	0.75	1.5	2.2	3.7	5.5	7.5	11	15	18.5	22
Motor Weight (kg)	8.5	11	20	24	40	49	54	100	125	160	180
Fan Weight (kg)	19	19	19	-	-	-	-	-	-	-	-
Total Weight (kg)	27.5	30	39	-	-	-	-	-	-	-	-

Unit : mm

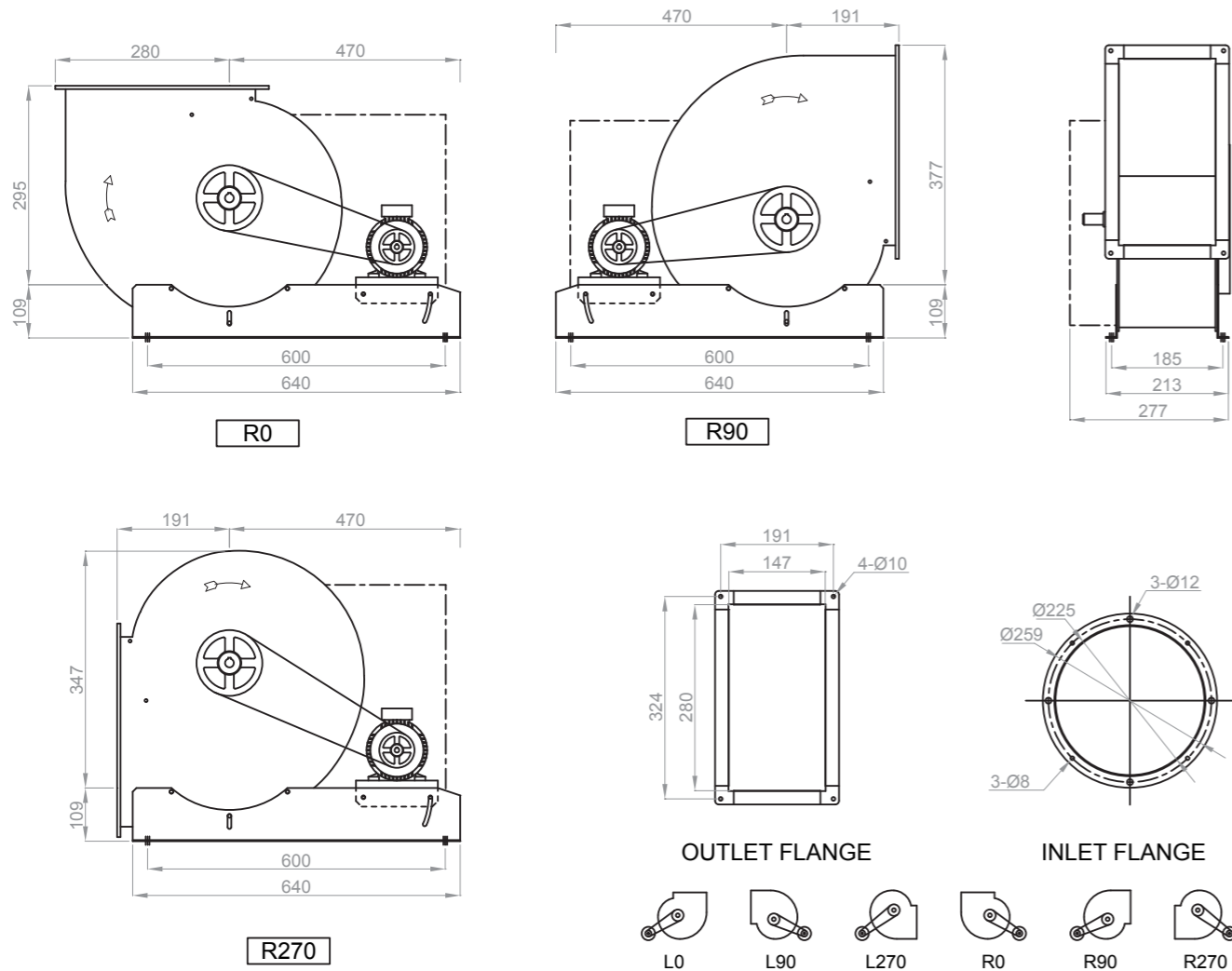

*Refer to page 40 for dimensions and weight of WFS 225 Overhung Type.

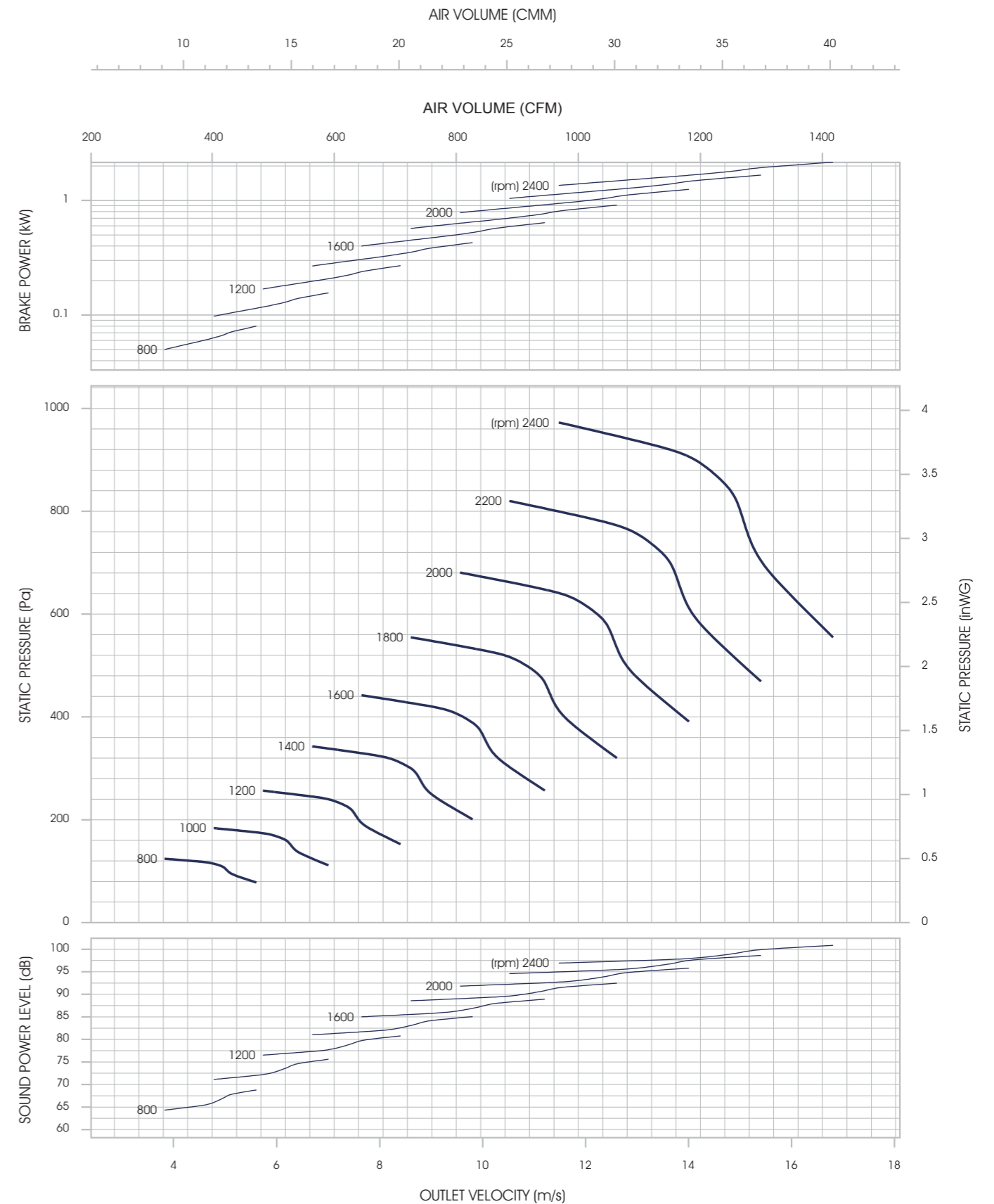

- 1) Power rating (B.kW) does not include transmission loss.
- 2) Performance ratings do not include the effects of appurtenances (accessories).
- 3) Performance certified is for installation type B - Free inlet, Ducted outlet.
- 4) The sound power level ratings shown are in decibels, referred to 10⁻¹² watts, calculated per AMCA International Standard 301.
- 5) Values shown are for inlet LWi sound power levels for Installation Type B: free inlet, ducted outlet.

WFS 250

Forward Curved Single Inlet SWSI

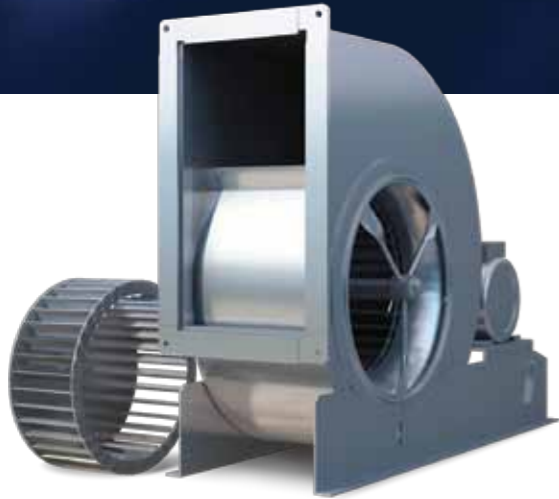

Wheel Diameter 250 mm.
Outlet Area 0.0505 m²
Material Casing: Galvanised Steel
 Impeller: Galvanised Steel
 Inlet Cone: Polyamide FRP
Rotation Forward

Motor (kW)	0.37	0.75	1.5	2.2	3.7	5.5	7.5	11	15	18.5	22
Motor Weight (kg)	8.5	11	20	24	40	49	54	100	125	160	180
Fan Weight (kg)	20	20	20	-	-	-	-	-	-	-	-
Total Weight (kg)	28.5	31	40	-	-	-	-	-	-	-	-

Unit : mm

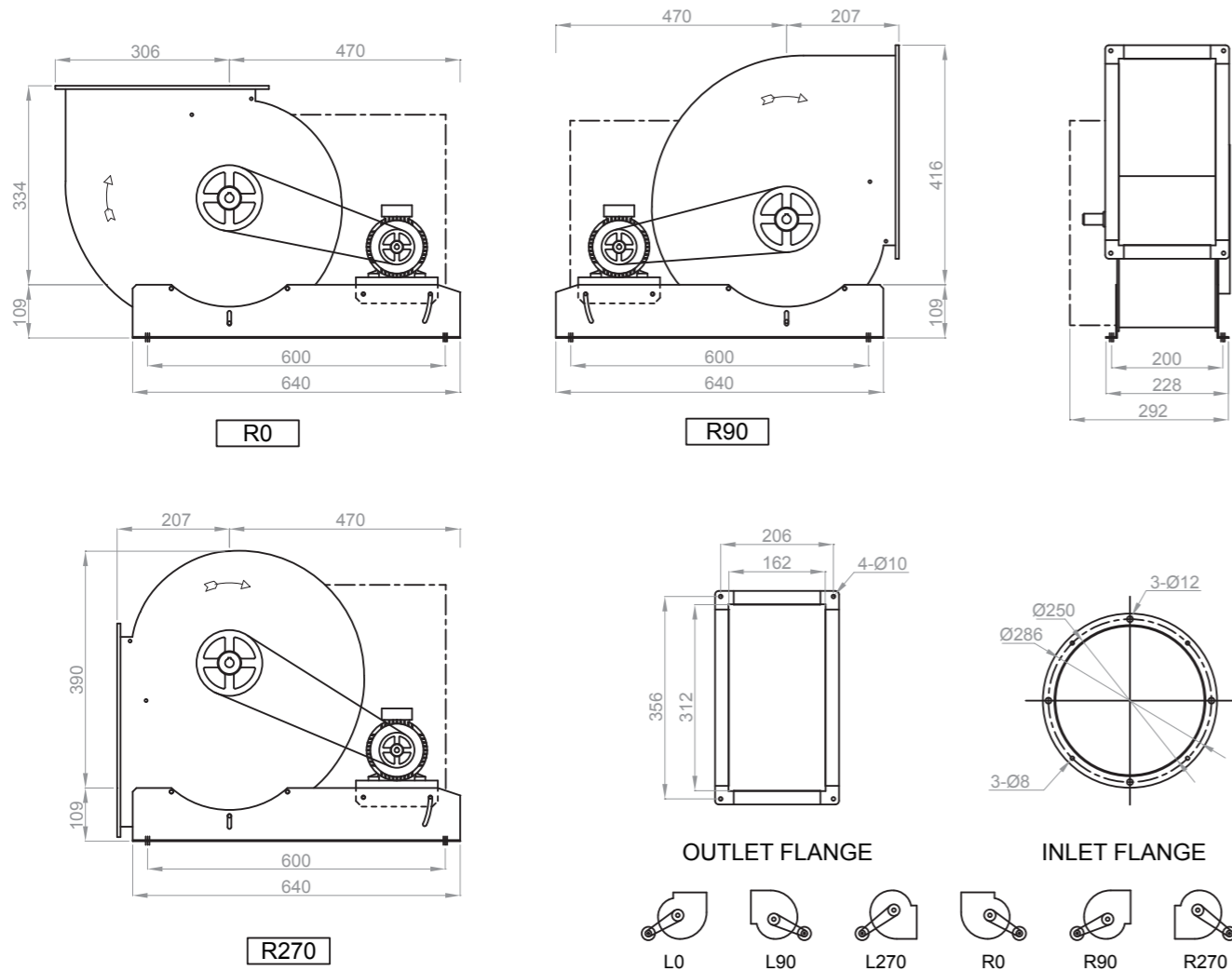

*Refer to page 40 for dimensions and weight of WFS 250 Overhung Type.

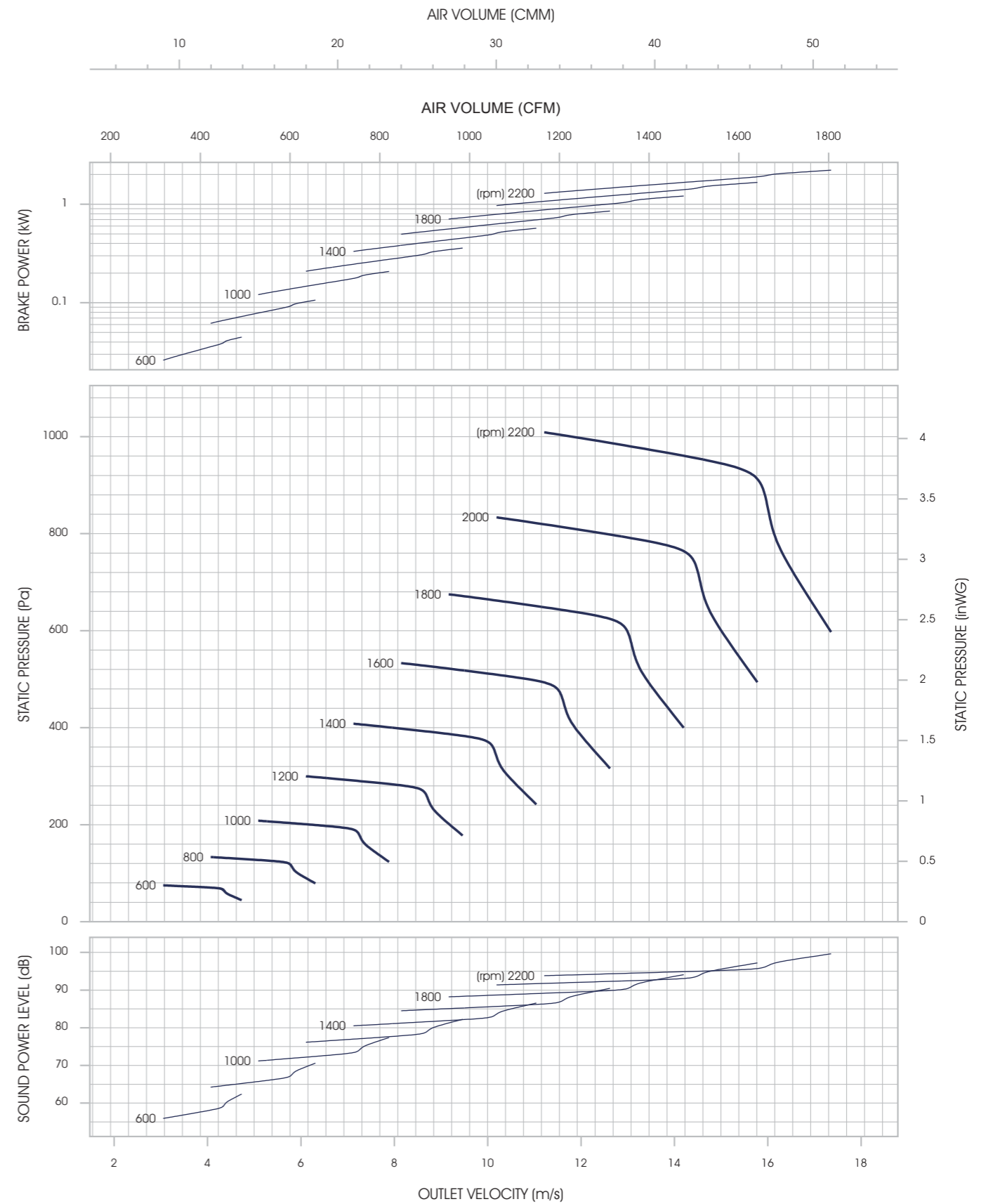

- 1) Power rating (B.kW) does not include transmission loss.
- 2) Performance ratings do not include the effects of appurtenances (accessories).
- 3) Performance certified is for installation type B - Free inlet, Ducted outlet.
- 4) The sound power level ratings shown are in decibels, referred to 10⁻¹² watts, calculated per AMCA International Standard 301.
- 5) Values shown are for inlet LWI sound power levels for Installation Type B: free inlet, ducted outlet.

WFS 280

Forward Curved Single Inlet SWSI



Wheel Diameter 280 mm.
Outlet Area 0.0644 m²
Material Casing: Galvanised Steel
 Impeller: Galvanised Steel
 Inlet Cone: Polyamide FRP
Rotation Forward

Motor (kW)	0.37	0.75	1.5	2.2	3.7	5.5	7.5	11	15	18.5	22
Motor Weight (kg)	8.5	11	20	24	40	49	54	100	125	160	180
Fan Weight (kg)	27	27	27	27	-	-	-	-	-	-	-
Total Weight (kg)	35.5	38	47	51	-	-	-	-	-	-	-

Unit : mm

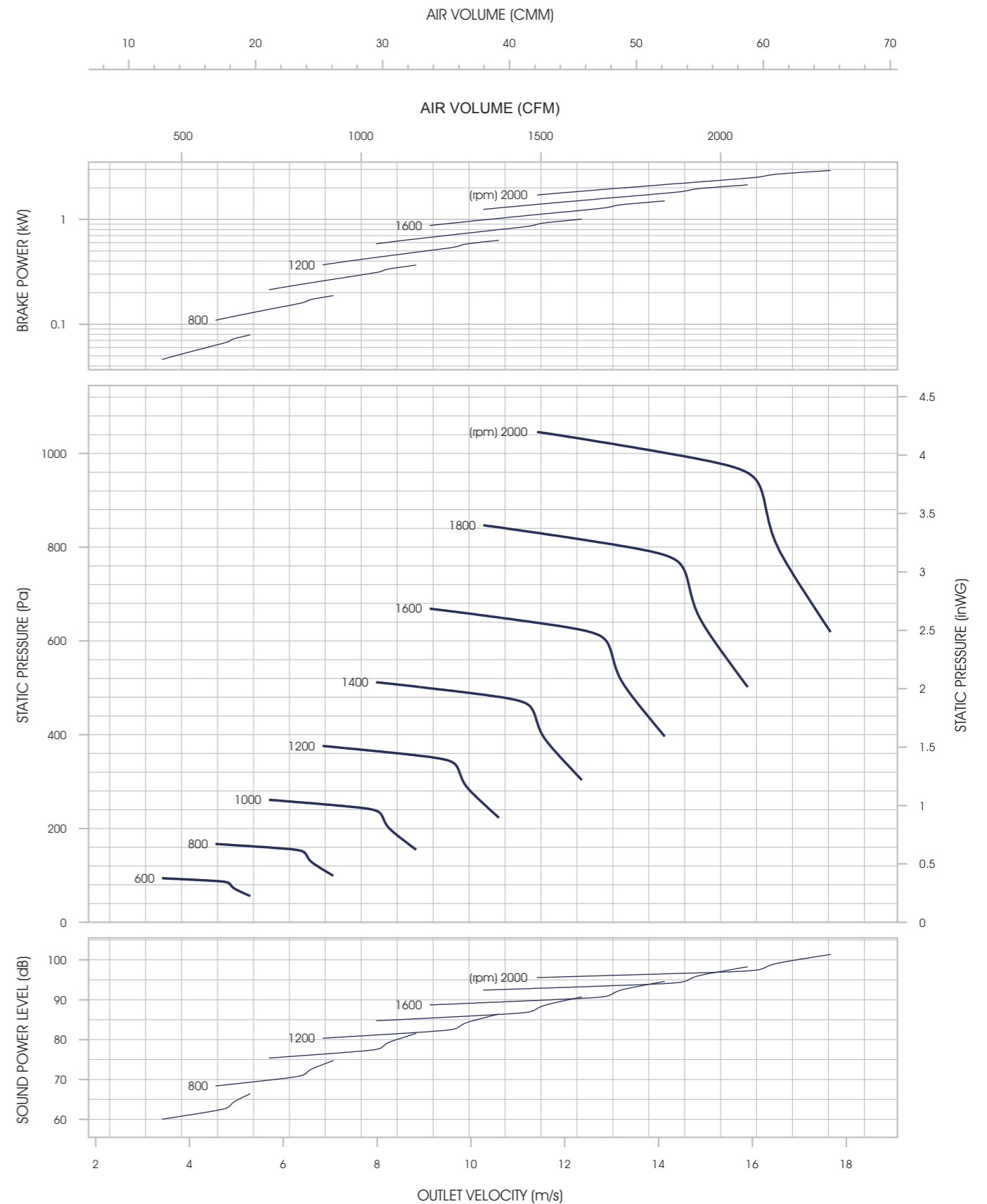
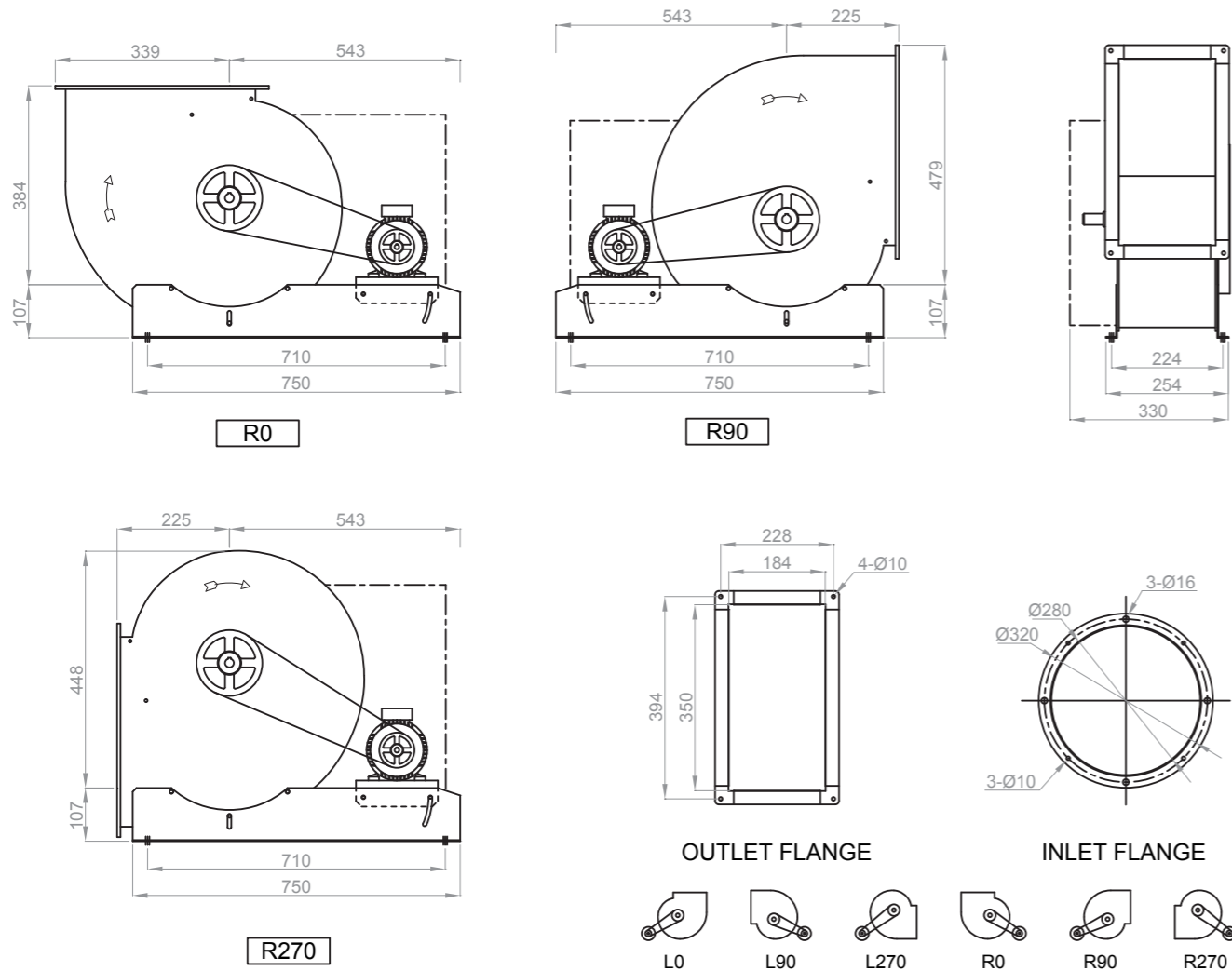

- 1) Power rating (B.kW) does not include transmission loss.
- 2) Performance ratings do not include the effects of appurtenances (accessories).
- 3) Performance certified is for installation type B - Free inlet, Ducted outlet.
- 4) The sound power level ratings shown are in decibels, referred to 10⁻¹² watts, calculated per AMCA International Standard 301.
- 5) Values shown are for inlet LWi sound power levels for Installation Type B: free inlet, ducted outlet.

*Refer to page 40 for dimensions and weight of WFS 280 Overhung Type.

WFS 315

Forward Curved Single Inlet SWSI



Wheel Diameter 315 mm.
Outlet Area 0.0808 m²
Material Casing: Galvanised Steel
 Impeller: Galvanised Steel
 Inlet Cone: Polyamide FRP
Rotation Forward

Motor (kW)	0.37	0.75	1.5	2.2	3.7	5.5	7.5	11	15	18.5	22
Motor Weight (kg)	8.5	11	20	24	40	49	54	100	125	160	180
Fan Weight (kg)	29	29	29	29	-	-	-	-	-	-	-
Total Weight (kg)	37.5	40	49	53	-	-	-	-	-	-	-

Unit : mm

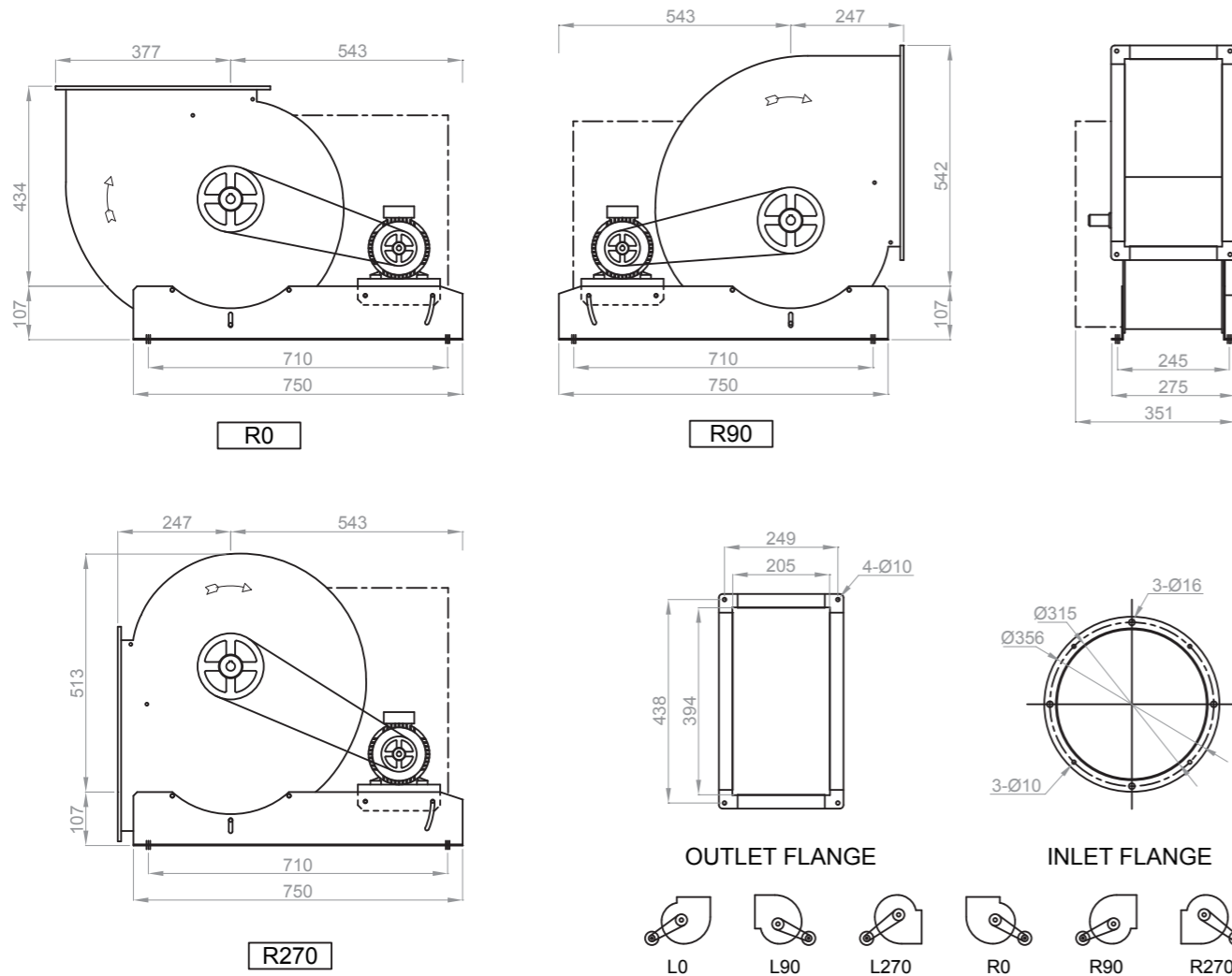

*Refer to page 40 for dimensions and weight of WFS 315 Overhung Type.

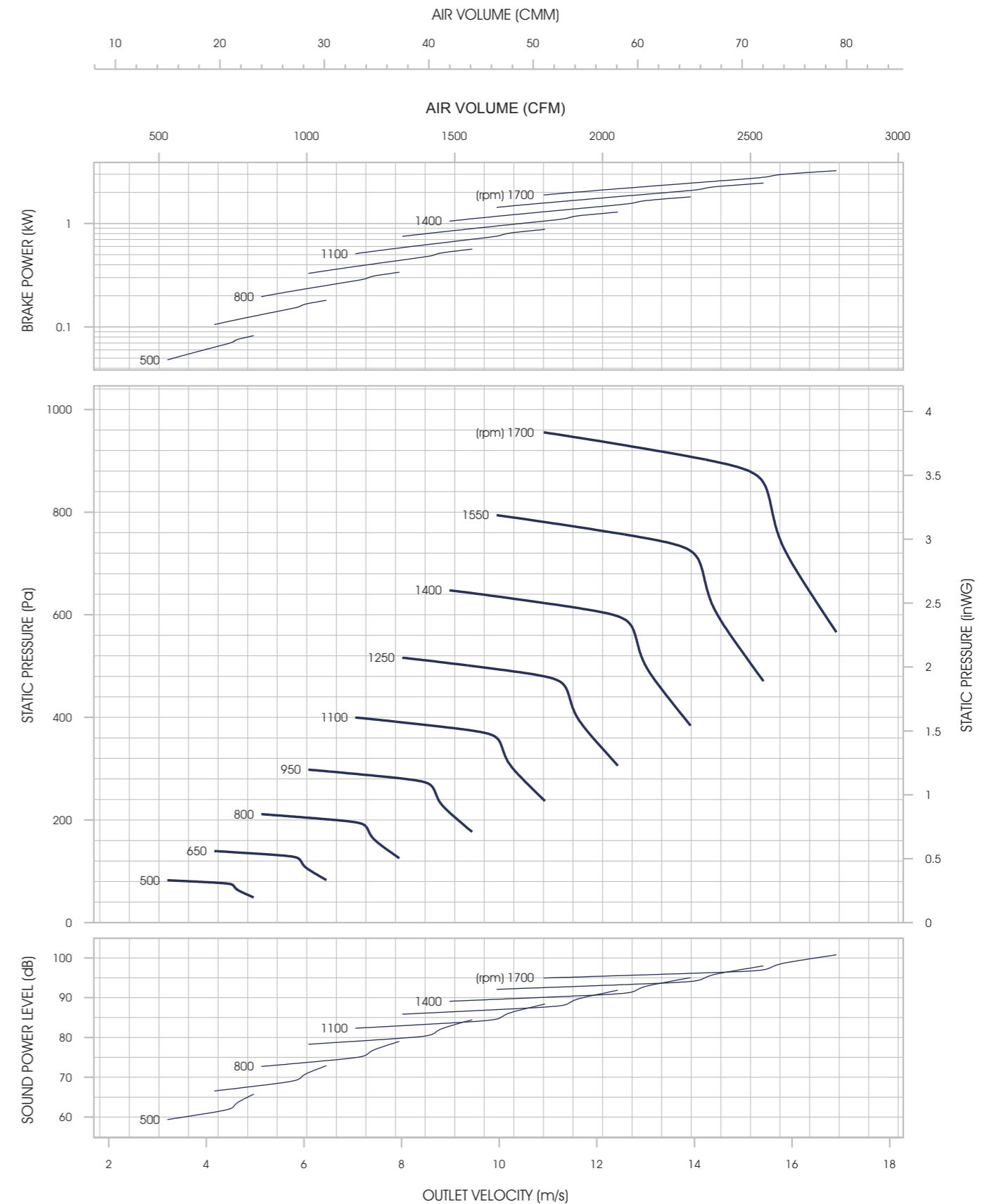

- 1) Power rating (B.kW) does not include transmission loss.
- 2) Performance ratings do not include the effects of appurtenances (accessories).
- 3) Performance certified is for installation type B - Free inlet, Ducted outlet.
- 4) The sound power level ratings shown are in decibels, referred to 10⁻¹² watts, calculated per AMCA International Standard 301.
- 5) Values shown are for inlet LWI sound power levels for Installation Type B: free inlet, ducted outlet.

WFS 355

Forward Curved Single Inlet SWSI



Wheel Diameter 355 mm.
Outlet Area 0.1035 m²
Material Casing: Galvanised Steel
 Impeller: Galvanised Steel
 Inlet Cone: Polyamide FRP
Rotation Forward

Motor (kW)	0.37	0.75	1.5	2.2	3.7	5.5	7.5	11	15	18.5	22
Motor Weight (kg)	8.5	11	20	24	40	49	54	100	125	160	180
Fan Weight (kg)	44	44	44	44	44	-	-	-	-	-	-
Total Weight (kg)	52.5	55	64	68	84	-	-	-	-	-	-

Unit : mm

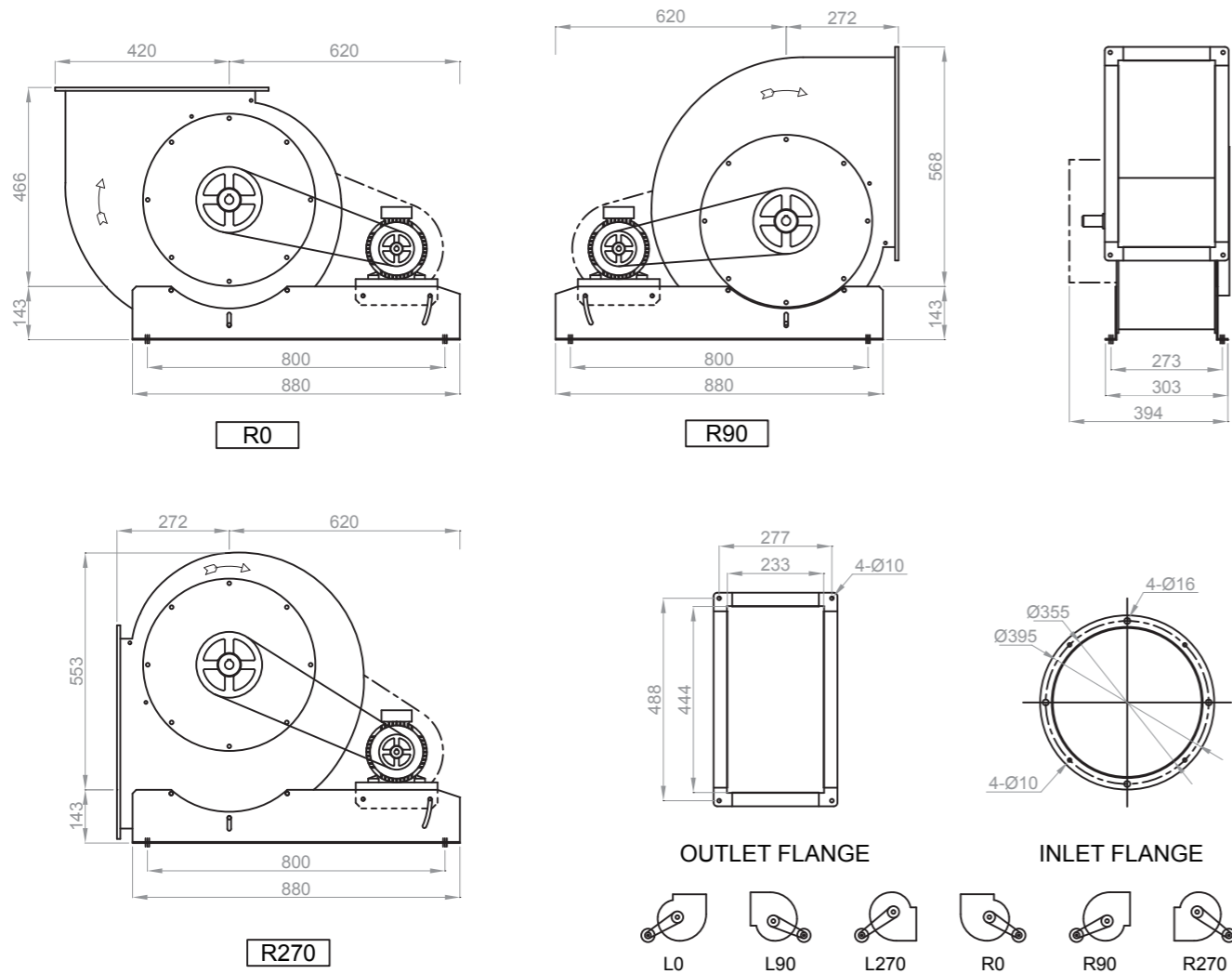

*Refer to page 40 for dimensions and weight of WFS 355 Overhung Type.

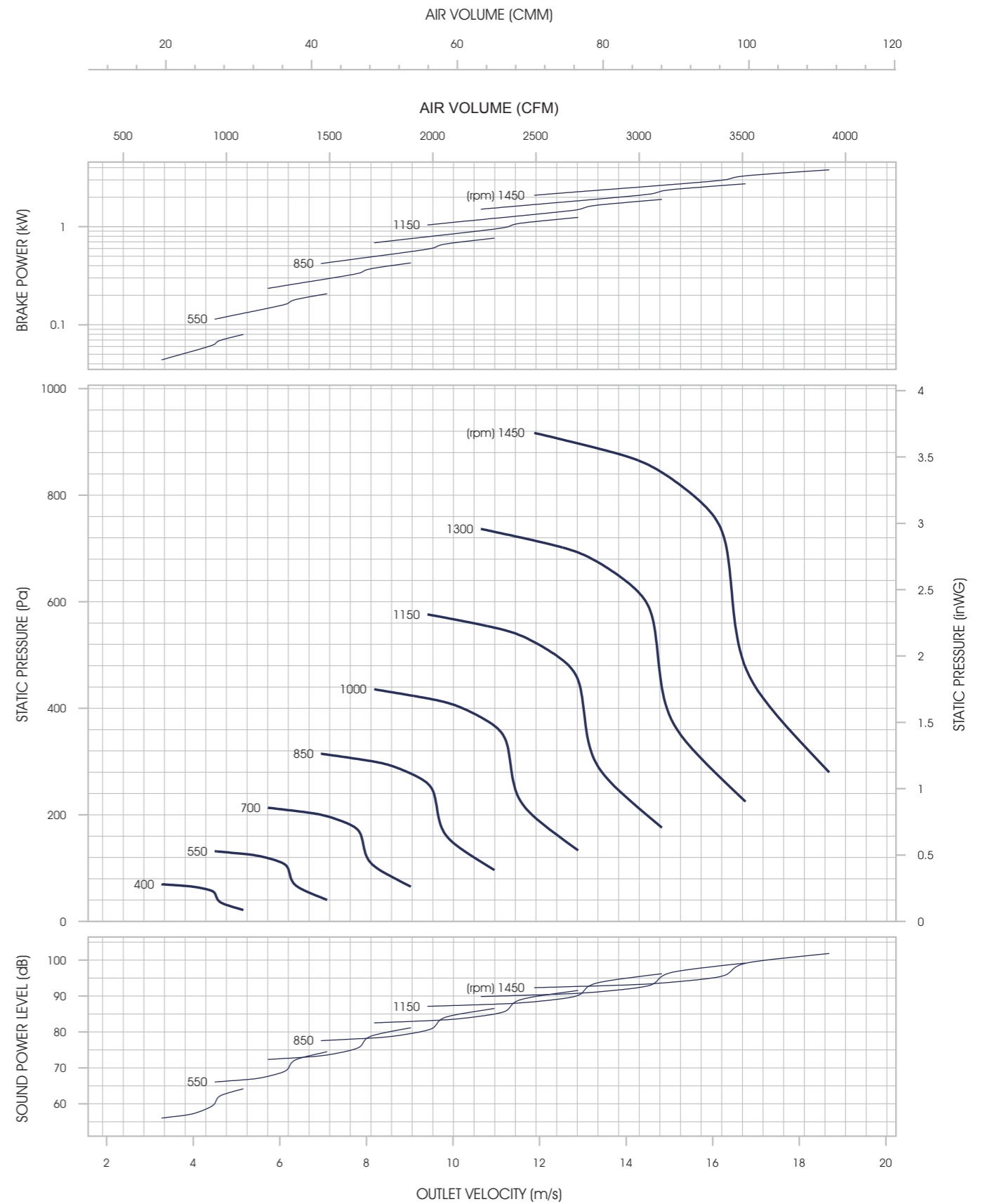

- 1) Power rating (B.kW) does not include transmission loss.
- 2) Performance ratings do not include the effects of appurtenances (accessories).
- 3) Performance certified is for installation type B - Free inlet, Ducted outlet.
- 4) The sound power level ratings shown are in decibels, referred to 10⁻¹² watts, calculated per AMCA International Standard 301.
- 5) Values shown are for inlet LWi sound power levels for Installation Type B: free inlet, ducted outlet.

WFS 400

Forward Curved Single Inlet SWSI



Wheel Diameter 400 mm.
Outlet Area 0.1295 m²
Material Casing: Galvanised Steel
 Impeller: Galvanised Steel
 Inlet Cone: Polyamide FRP
Rotation Forward

Motor (kW)	0.37	0.75	1.5	2.2	3.7	5.5	7.5	11	15	18.5	22
Motor Weight (kg)	8.5	11	20	24	40	49	54	100	125	160	180
Fan Weight (kg)	47	47	47	47	47	-	-	-	-	-	-
Total Weight (kg)	55.5	58	67	71	87	-	-	-	-	-	-

Unit : mm

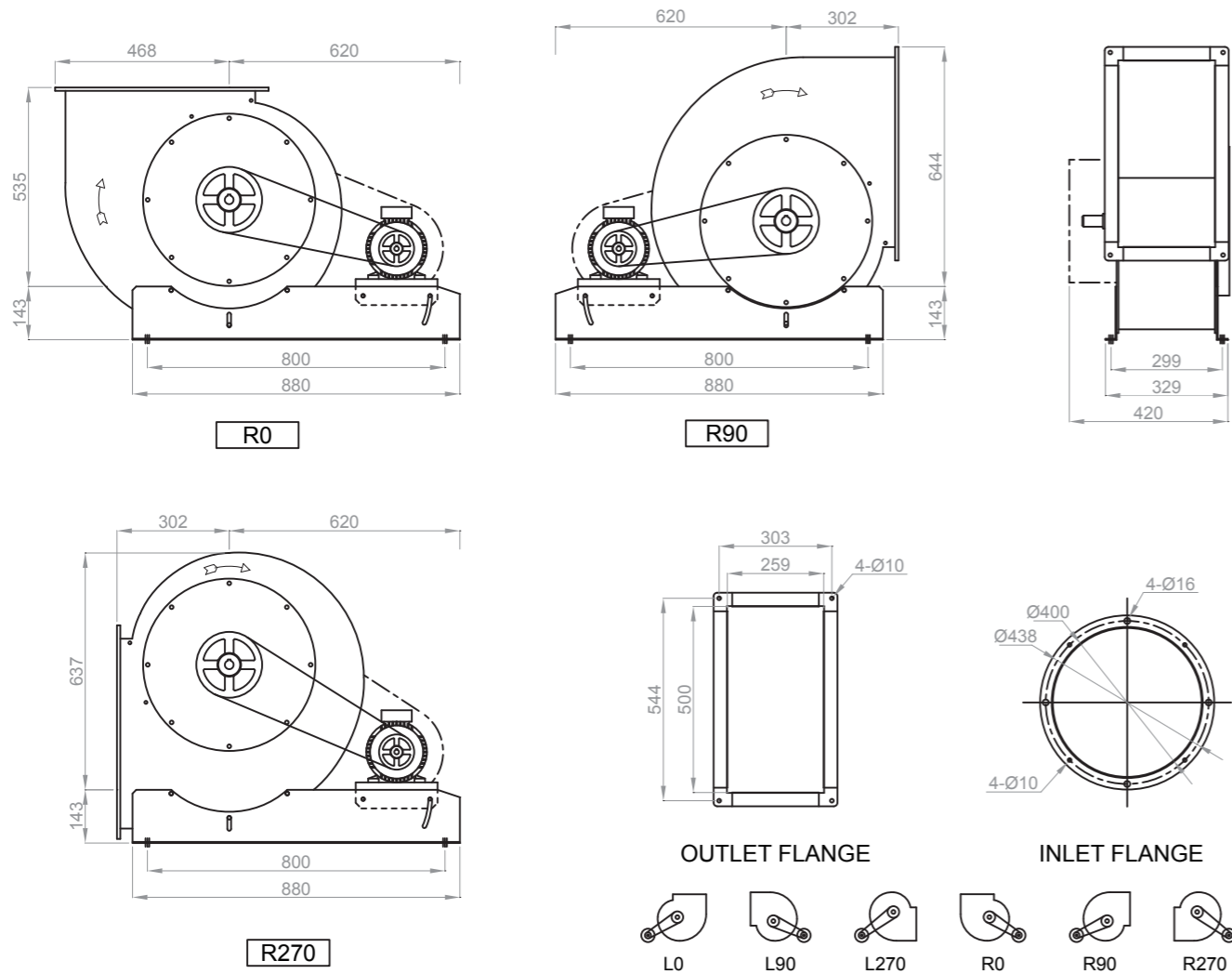

*Refer to page 41 for dimensions and weight of WFS 400 Overhung Type.

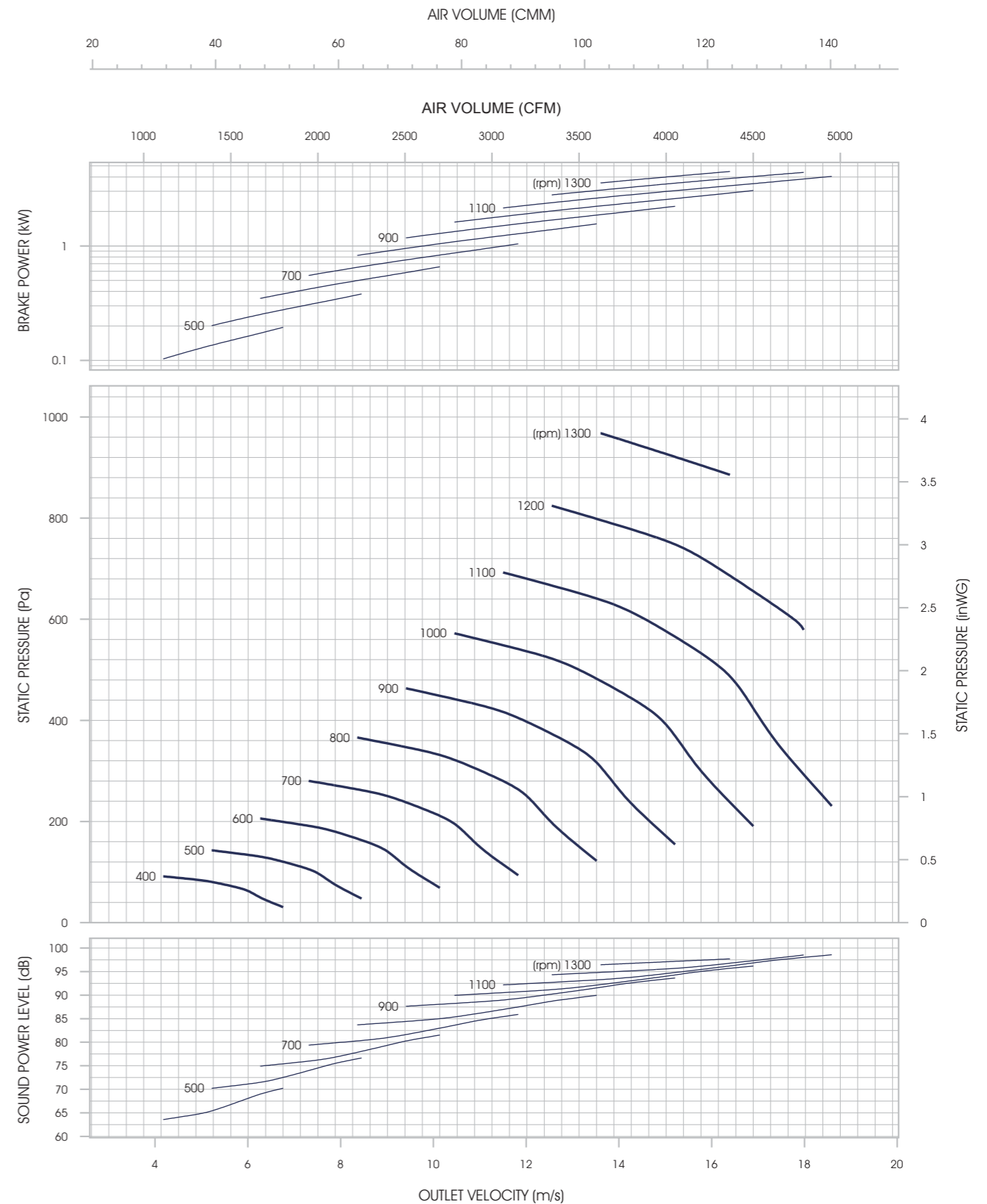

- 1) Power rating (B.kW) does not include transmission loss.
- 2) Performance ratings do not include the effects of appurtenances (accessories).
- 3) Performance certified is for installation type B - Free inlet, Ducted outlet.
- 4) The sound power level ratings shown are in decibels, referred to 10⁻¹² watts, calculated per AMCA International Standard 301.
- 5) Values shown are for inlet LWI sound power levels for Installation Type B: free inlet, ducted outlet.

WFS 450

Forward Curved Single Inlet SWSI



Wheel Diameter 450 mm.
Outlet Area 0.1641 m²
Material Casing: Galvanised Steel
 Impeller: Galvanised Steel
 Inlet Cone: Polyamide FRP
Rotation Forward

Motor (kW)	0.37	0.75	1.5	2.2	3.7	5.5	7.5	11	15	18.5	22
Motor Weight (kg)	8.5	11	20	24	40	49	54	100	125	160	180
Fan Weight (kg)	-	66	66	66	66	-	-	-	-	-	-
Total Weight (kg)	-	77	86	90	106	-	-	-	-	-	-

Unit : mm

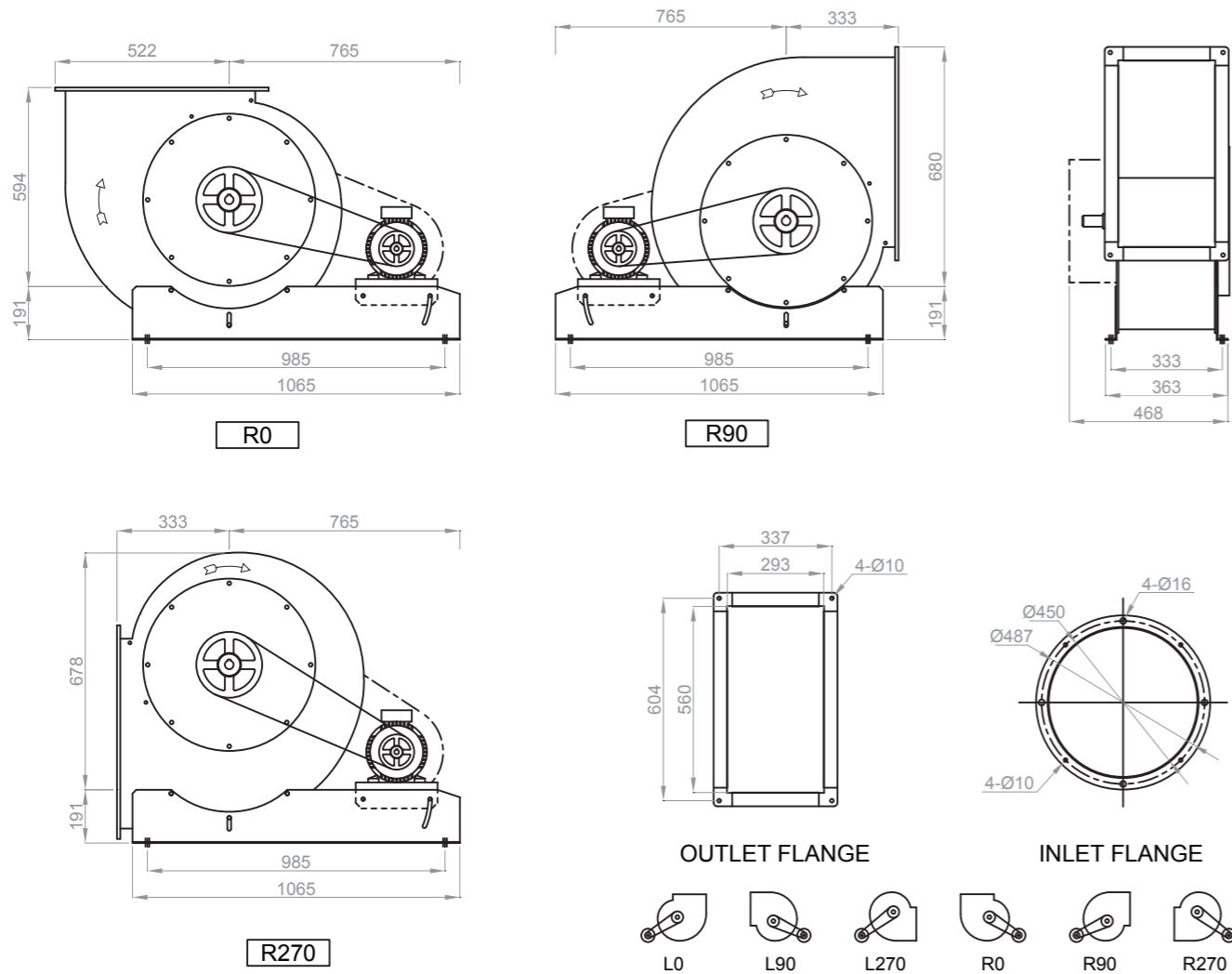

*Refer to page 41 for dimensions and weight of WFS 450 Overhung Type.

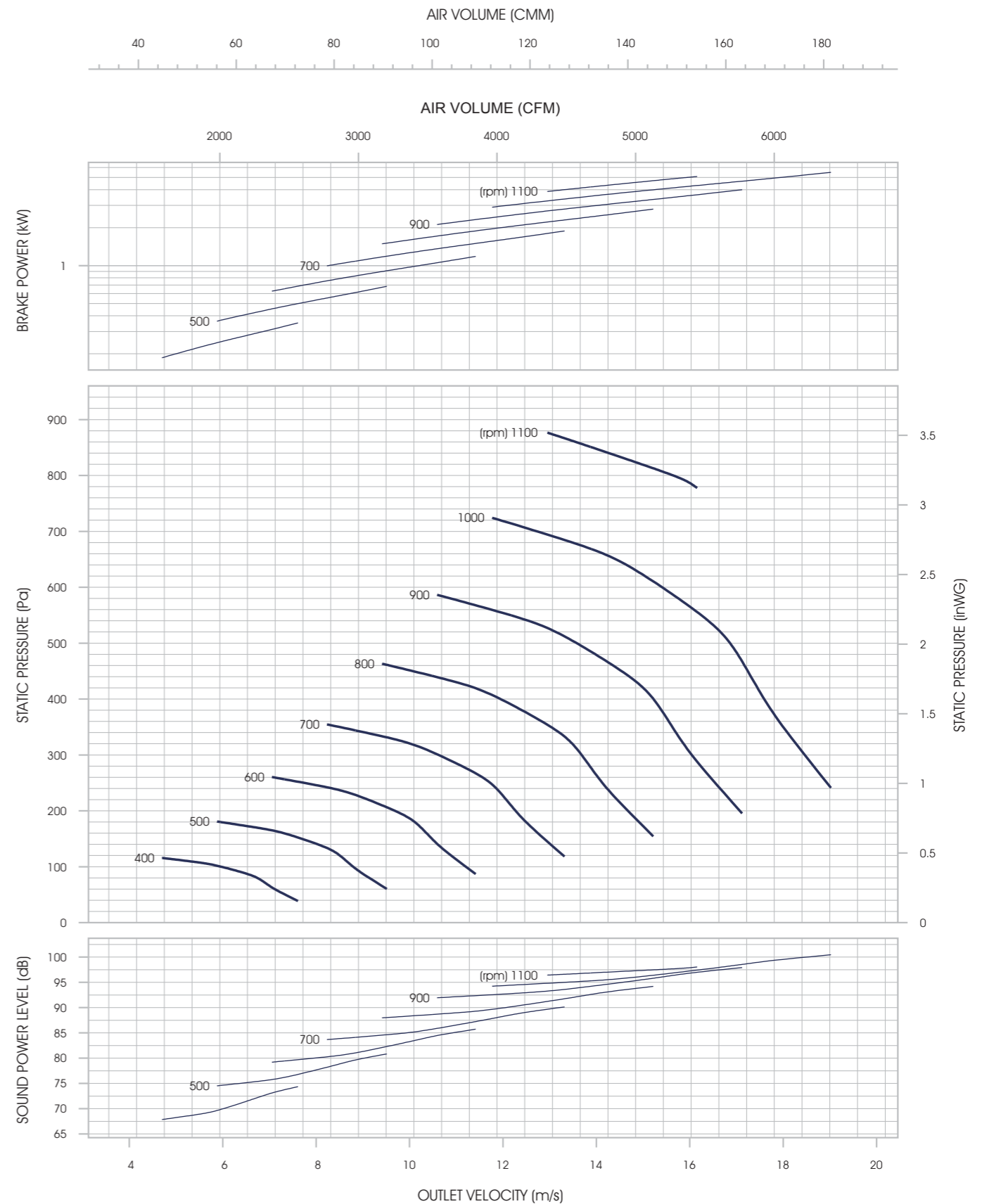

- 1) Power rating (B.kW) does not include transmission loss.
- 2) Performance ratings do not include the effects of appurtenances (accessories).
- 3) Performance certified is for installation type B - Free inlet, Ducted outlet.
- 4) The sound power level ratings shown are in decibels, referred to 10⁻¹² watts, calculated per AMCA International Standard 301.
- 5) Values shown are for inlet LWi sound power levels for Installation Type B: free inlet, ducted outlet.

WFS 500

Forward Curved Single Inlet SWSI



Wheel Diameter 500 mm.
Outlet Area 0.2041 m²
Material Casing: Galvanised Steel
 Impeller: Galvanised Steel
 Inlet Cone: Polyamide FRP
Rotation Forward

Motor (kW)	0.37	0.75	1.5	2.2	3.7	5.5	7.5	11	15	18.5	22
Motor Weight (kg)	8.5	11	20	24	40	49	54	100	125	160	180
Fan Weight (kg)	-	78	78	78	78	78	-	-	-	-	-
Total Weight (kg)	-	89	98	102	118	127	-	-	-	-	-

Unit : mm

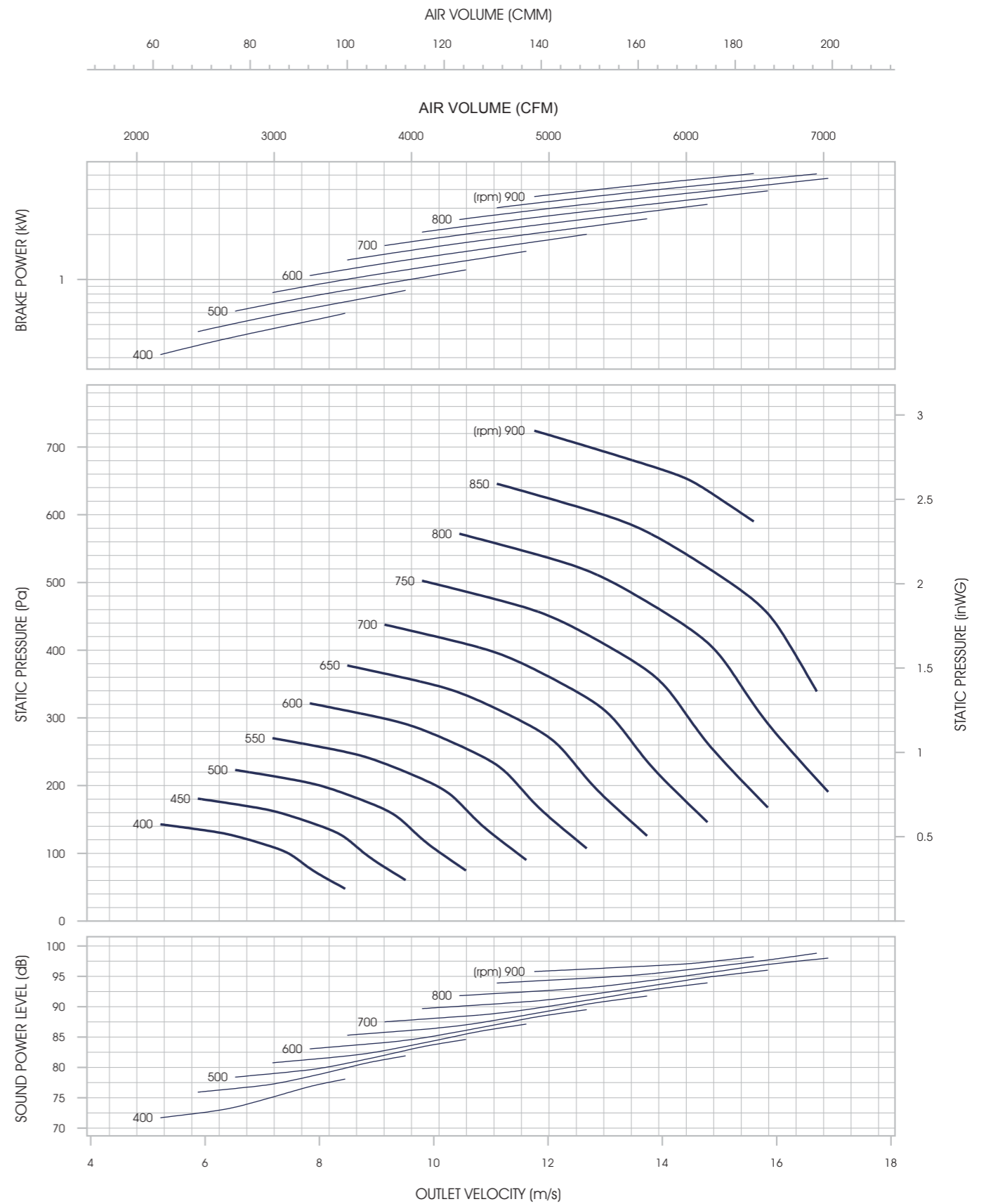
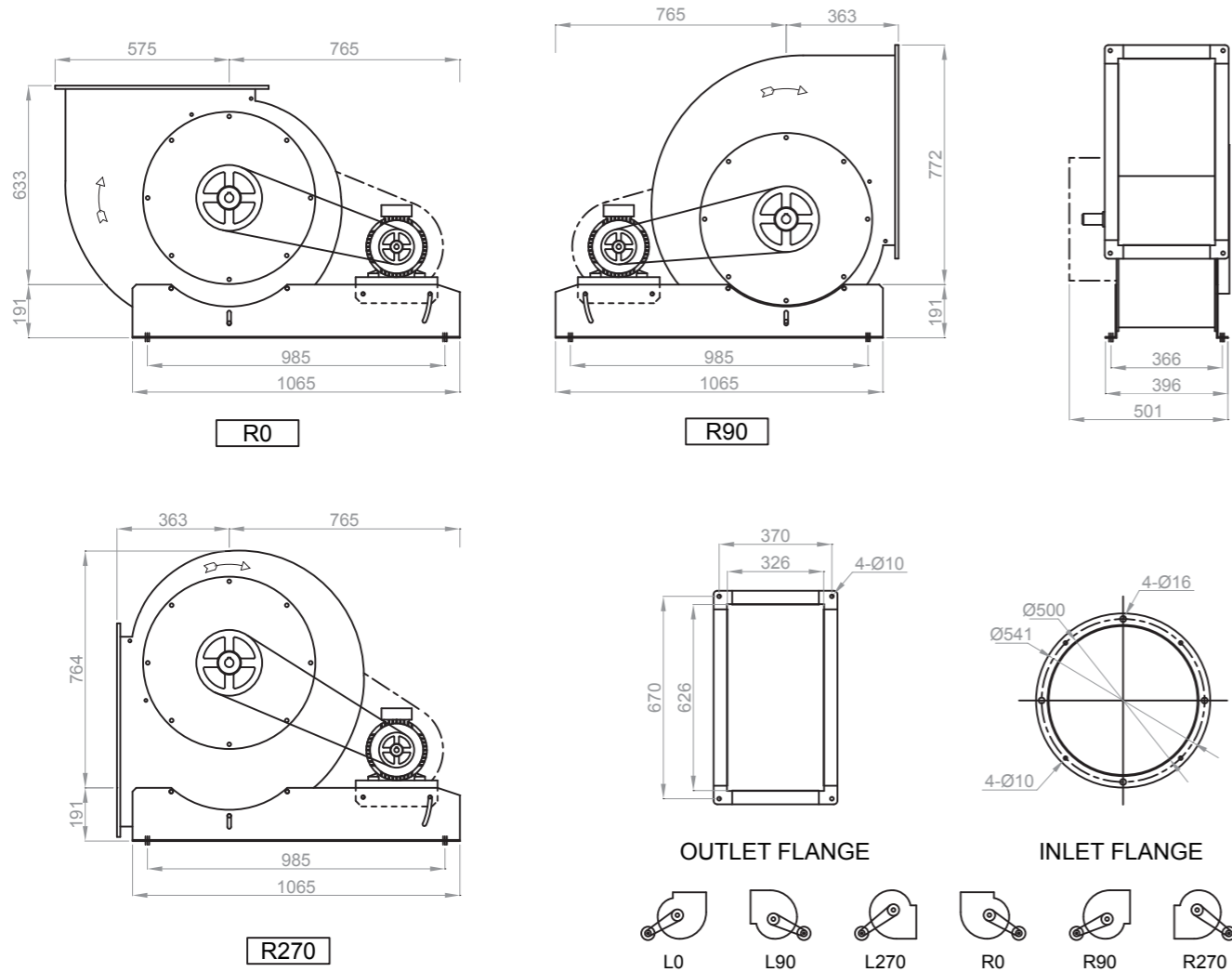

- 1) Power rating (B.kW) does not include transmission loss.
- 2) Performance ratings do not include the effects of appurtenances (accessories).
- 3) Performance certified is for installation type B - Free inlet, Ducted outlet.
- 4) The sound power level ratings shown are in decibels, referred to 10⁻¹² watts, calculated per AMCA International Standard 301.
- 5) Values shown are for inlet LWi sound power levels for Installation Type B: free inlet, ducted outlet.

*Refer to page 41 for dimensions and weight of WFS 500 Overhung Type.

WFS 560

Forward Curved Single Inlet SWSI



Wheel Diameter 560 mm.
Outlet Area 0.2576 m²
Material Casing: Galvanised Steel
 Impeller: Galvanised Steel
 Inlet Cone: Polyamide FRP
Rotation Forward

Motor (kW)	0.37	0.75	1.5	2.2	3.7	5.5	7.5	11	15	18.5	22
Motor Weight (kg)	8.5	11	20	24	40	49	54	100	125	160	180
Fan Weight (kg)	-	130	130	130	130	130	-	-	-	-	-
Total Weight (kg)	-	141	150	154	170	179	-	-	-	-	-

Unit : mm

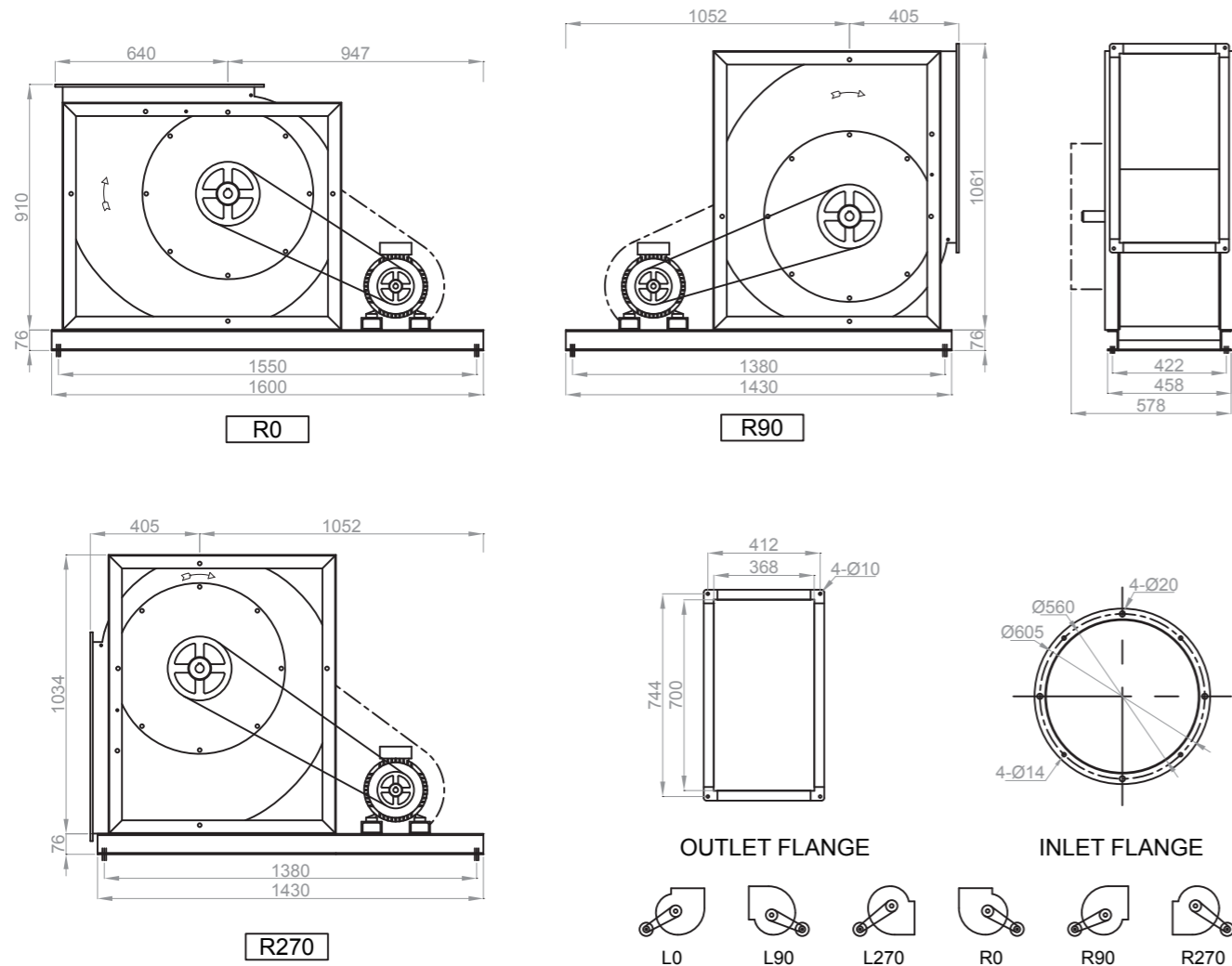

*Refer to page 41 for dimensions and weight of WFS 560 Overhung Type.

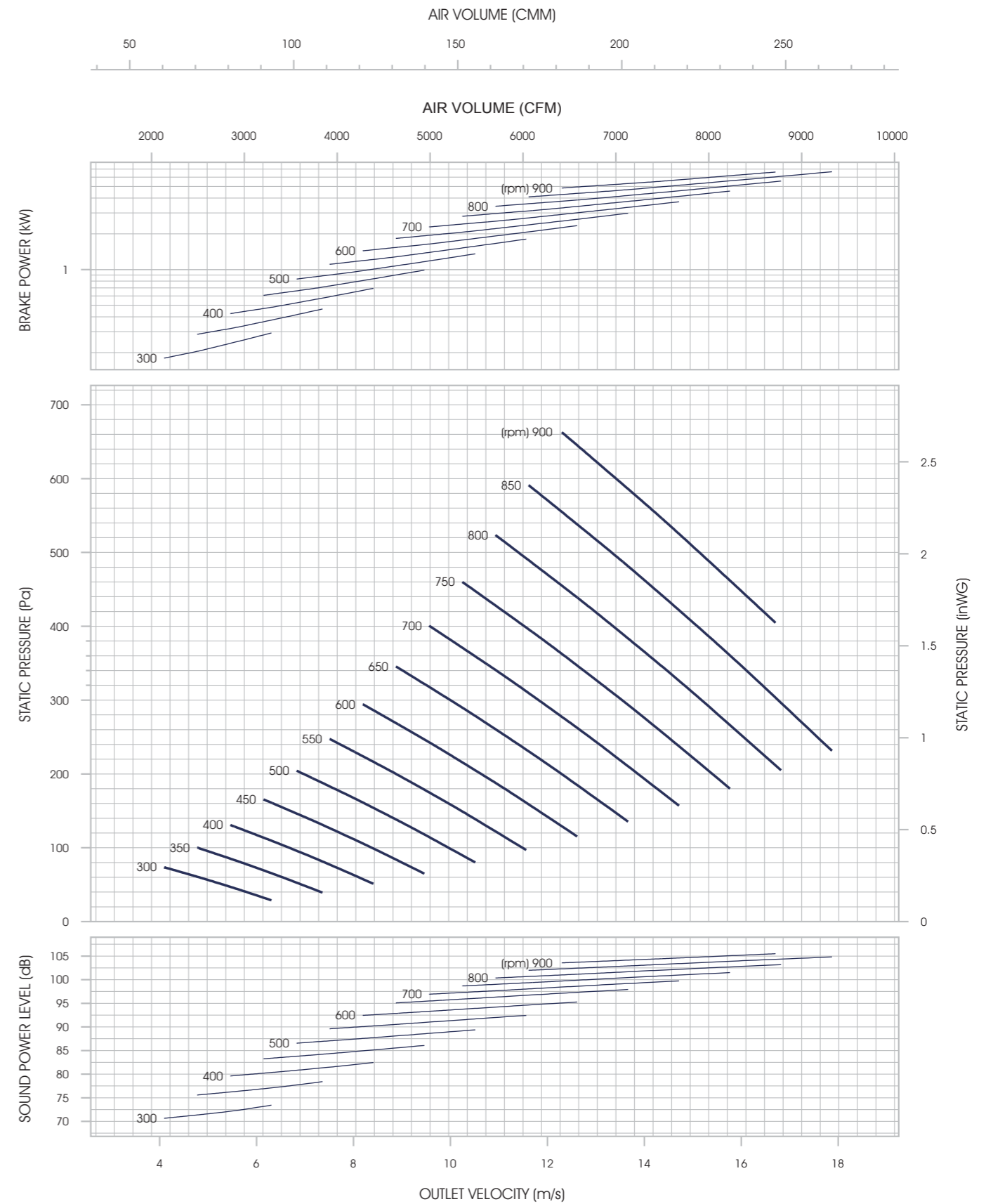

- 1) Power rating (B.kW) does not include transmission loss.
- 2) Performance ratings do not include the effects of appurtenances (accessories).
- 3) Performance certified is for installation type B - Free inlet, Ducted outlet.
- 4) The sound power level ratings shown are in decibels, referred to 10⁻¹² watts, calculated per AMCA International Standard 301.
- 5) Values shown are for inlet LWi sound power levels for Installation Type B: free inlet, ducted outlet.

WFS 630

Forward Curved Single Inlet SWSI



Wheel Diameter 630 mm.
Outlet Area 0.3262 m²
Material Casing: Galvanised Steel
 Impeller: Galvanised Steel
 Inlet Cone: Polyamide FRP
Rotation Forward

Motor (kW)	0.37	0.75	1.5	2.2	3.7	5.5	7.5	11	15	18.5	22
Motor Weight (kg)	8.5	11	20	24	40	49	54	100	125	160	180
Fan Weight (kg)	-	-	141	141	141	141	141	-	-	-	-
Total Weight (kg)	-	-	161	165	181	190	195	-	-	-	-

Unit : mm

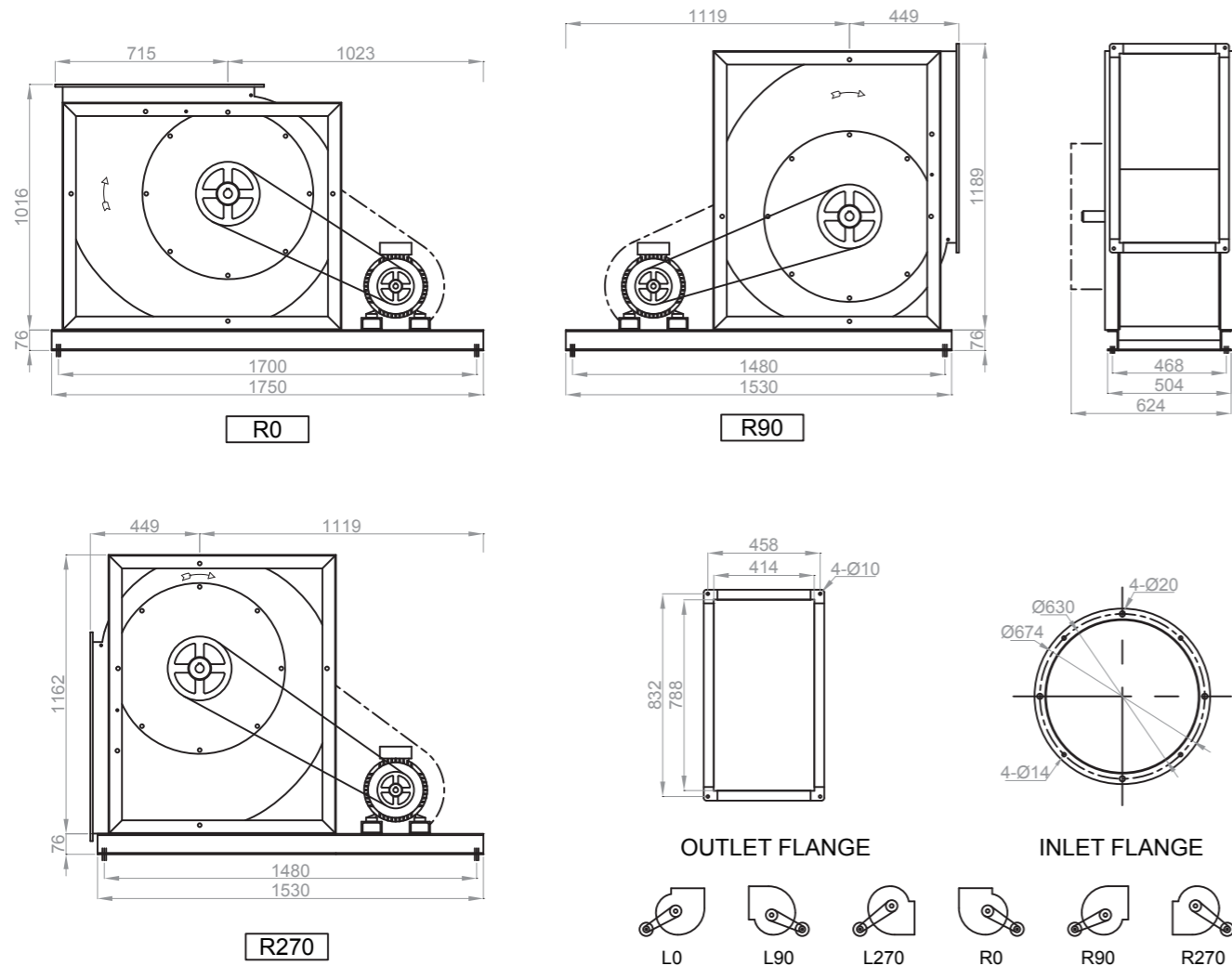

*Refer to page 41 for dimensions and weight of WFS 630 Overhung Type.

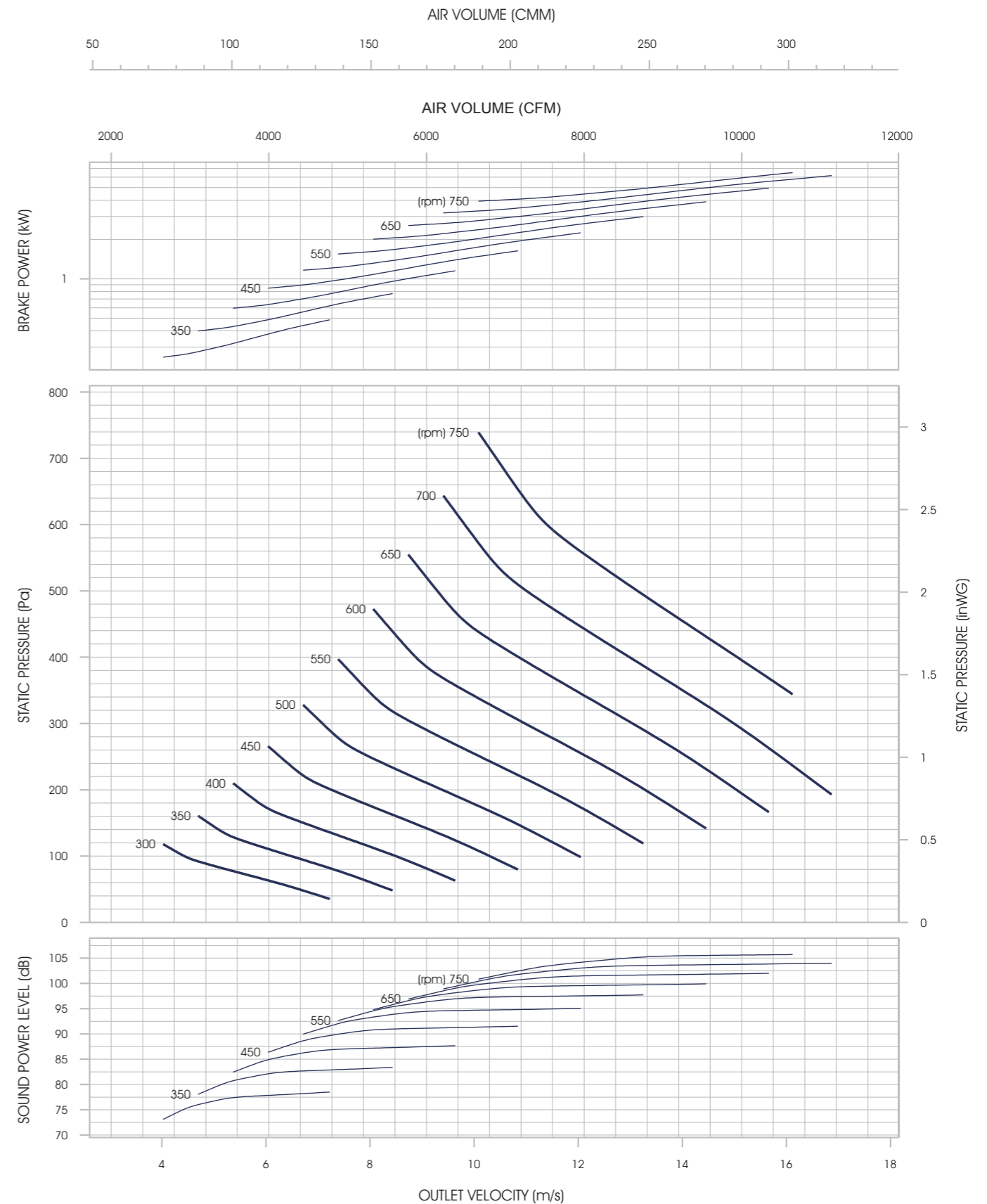

- 1) Power rating (B.kW) does not include transmission loss.
- 2) Performance ratings do not include the effects of appurtenances (accessories).
- 3) Performance certified is for installation type B - Free inlet, Ducted outlet.
- 4) The sound power level ratings shown are in decibels, referred to 10⁻¹² watts, calculated per AMCA International Standard 301.
- 5) Values shown are for inlet LWI sound power levels for Installation Type B: free inlet, ducted outlet.

WFS 710

Forward Curved Single Inlet SWSI



Wheel Diameter 710 mm.
Outlet Area 0.4192 m²
Material Casing: Galvanised Steel
 Impeller: Galvanised Steel
 Inlet Cone: Polyamide FRP
Rotation Forward

Motor (kW)	0.37	0.75	1.5	2.2	3.7	5.5	7.5	11	15	18.5	22
Motor Weight (kg)	8.5	11	20	24	40	49	54	100	125	160	180
Fan Weight (kg)	-	-	232	232	232	232	232	232	-	-	-
Total Weight (kg)	-	-	252	256	272	281	286	332	-	-	-

Unit : mm

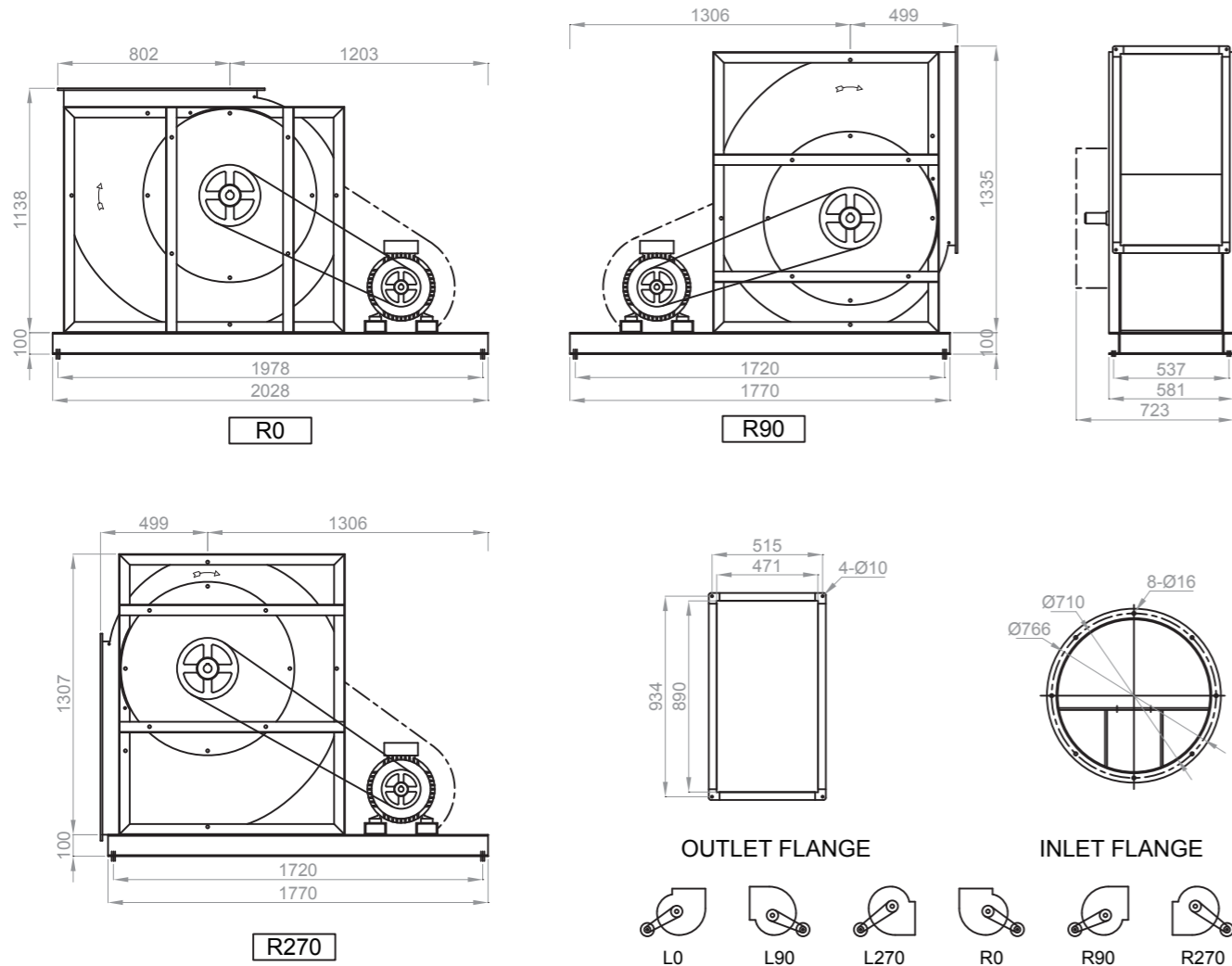

*Refer to page 42 for dimensions and weight of WFS 710 Overhung Type.

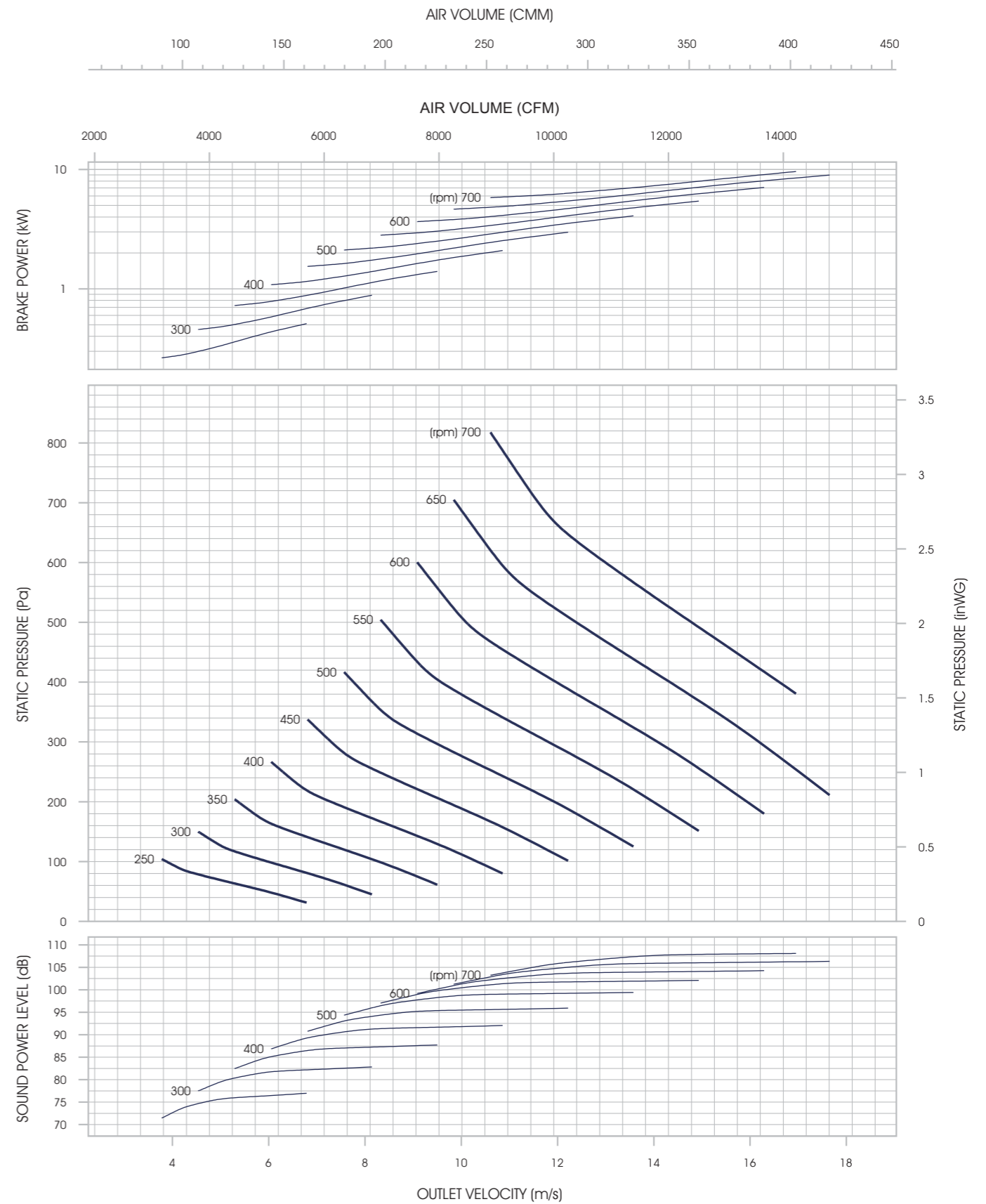

- 1) Power rating (B.kW) does not include transmission loss.
- 2) Performance ratings do not include the effects of appurtenances (accessories).
- 3) Performance certified is for installation type B - Free inlet, Ducted outlet.
- 4) The sound power level ratings shown are in decibels, referred to 10⁻¹² watts, calculated per AMCA International Standard 301.
- 5) Values shown are for inlet LWi sound power levels for Installation Type B: free inlet, ducted outlet.

WFS 800

Forward Curved Single Inlet SWSI



Wheel Diameter 800 mm.
Outlet Area 0.529 m²
Material Casing: Galvanised Steel
 Impeller: Galvanised Steel
 Inlet Cone: Polyamide FRP
Rotation Forward

Motor (kW)	0.37	0.75	1.5	2.2	3.7	5.5	7.5	11	15	18.5	22
Motor Weight (kg)	8.5	11	20	24	40	49	54	100	125	160	180
Fan Weight (kg)	-	-	243	243	243	243	243	243	243	-	-
Total Weight (kg)	-	-	263	267	283	292	297	343	368	-	-

Unit : mm

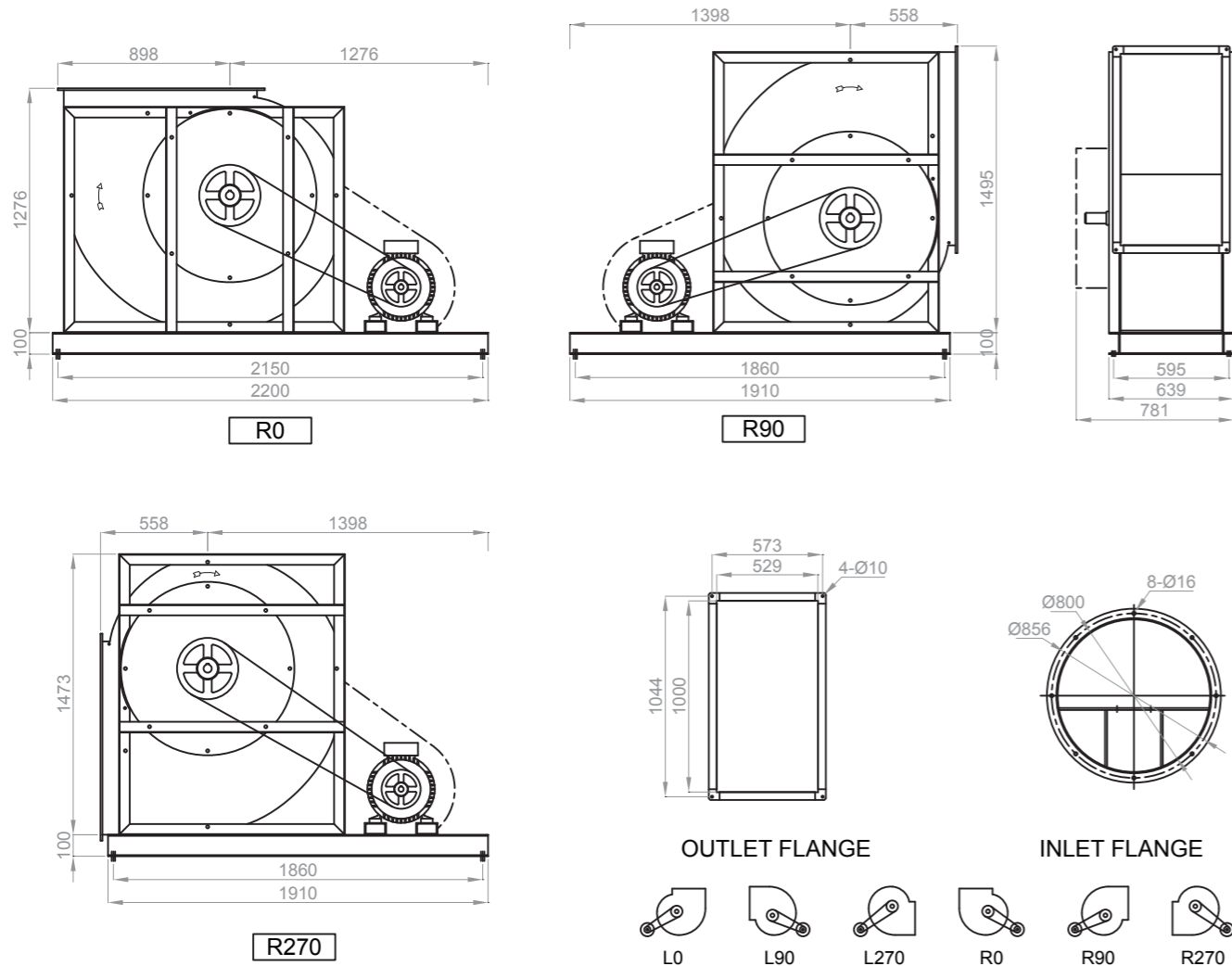

*Refer to page 42 for dimensions and weight of WFS 800 Overhung Type.

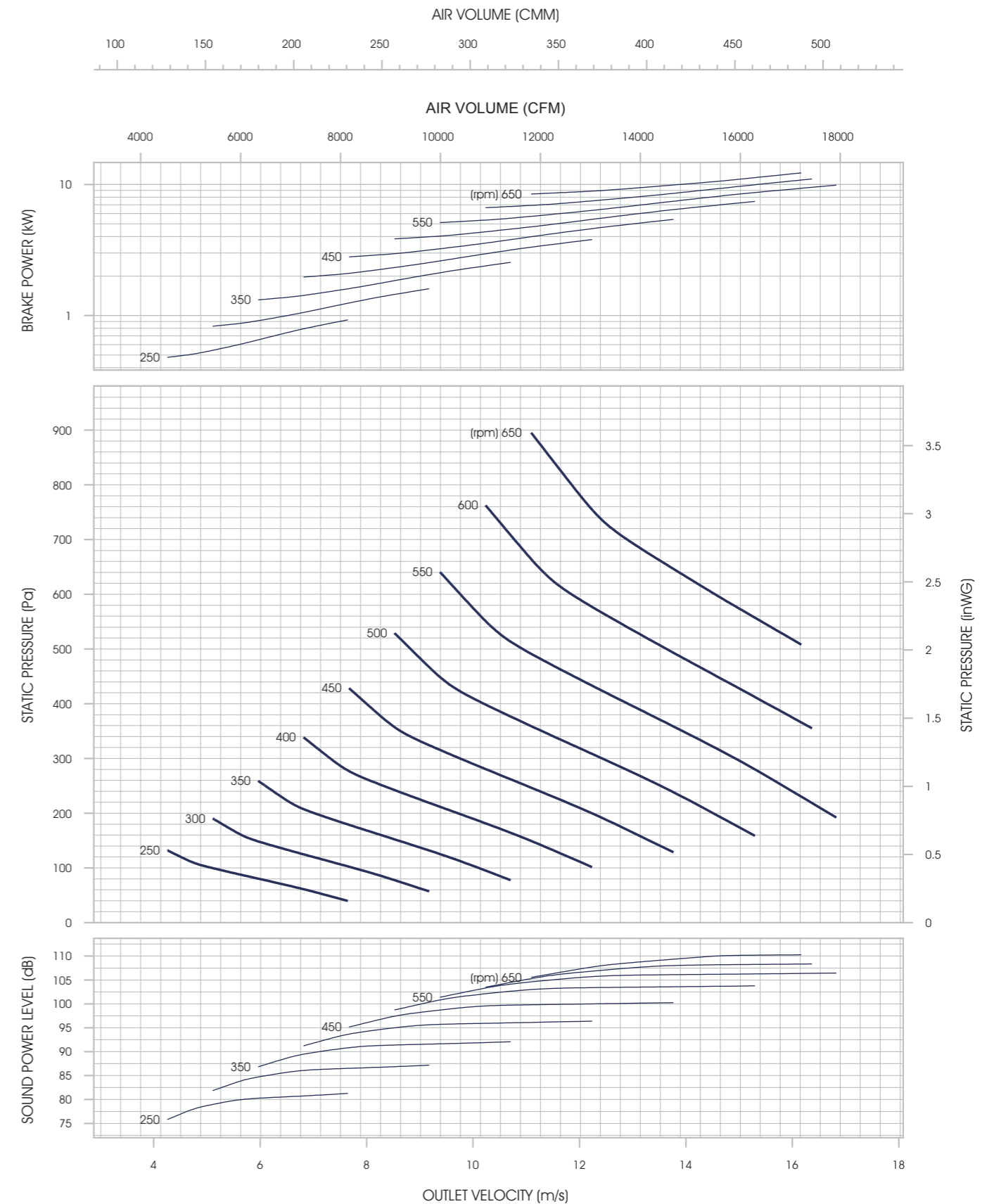

- 1) Power rating (B.kW) does not include transmission loss.
- 2) Performance ratings do not include the effects of appurtenances (accessories).
- 3) Performance certified is for installation type B - Free inlet, Ducted outlet.
- 4) The sound power level ratings shown are in decibels, referred to 10⁻¹² watts, calculated per AMCA International Standard 301.
- 5) Values shown are for inlet LWI sound power levels for Installation Type B: free inlet, ducted outlet.

WFS 900

Forward Curved Single Inlet SWSI



Wheel Diameter 900 mm.
Outlet Area 0.669 m²
Material Casing: Galvanised Steel
 Impeller: Galvanised Steel
 Inlet Cone: Polyamide FRP
Rotation Forward

Motor (kW)	0.37	0.75	1.5	2.2	3.7	5.5	7.5	11	15	18.5	22
Motor Weight (kg)	8.5	11	20	24	40	49	54	100	125	160	180
Fan Weight (kg)	-	-	-	319	319	319	319	319	319	-	-
Total Weight (kg)	-	-	-	343	359	368	373	419	444	-	-

Unit : mm

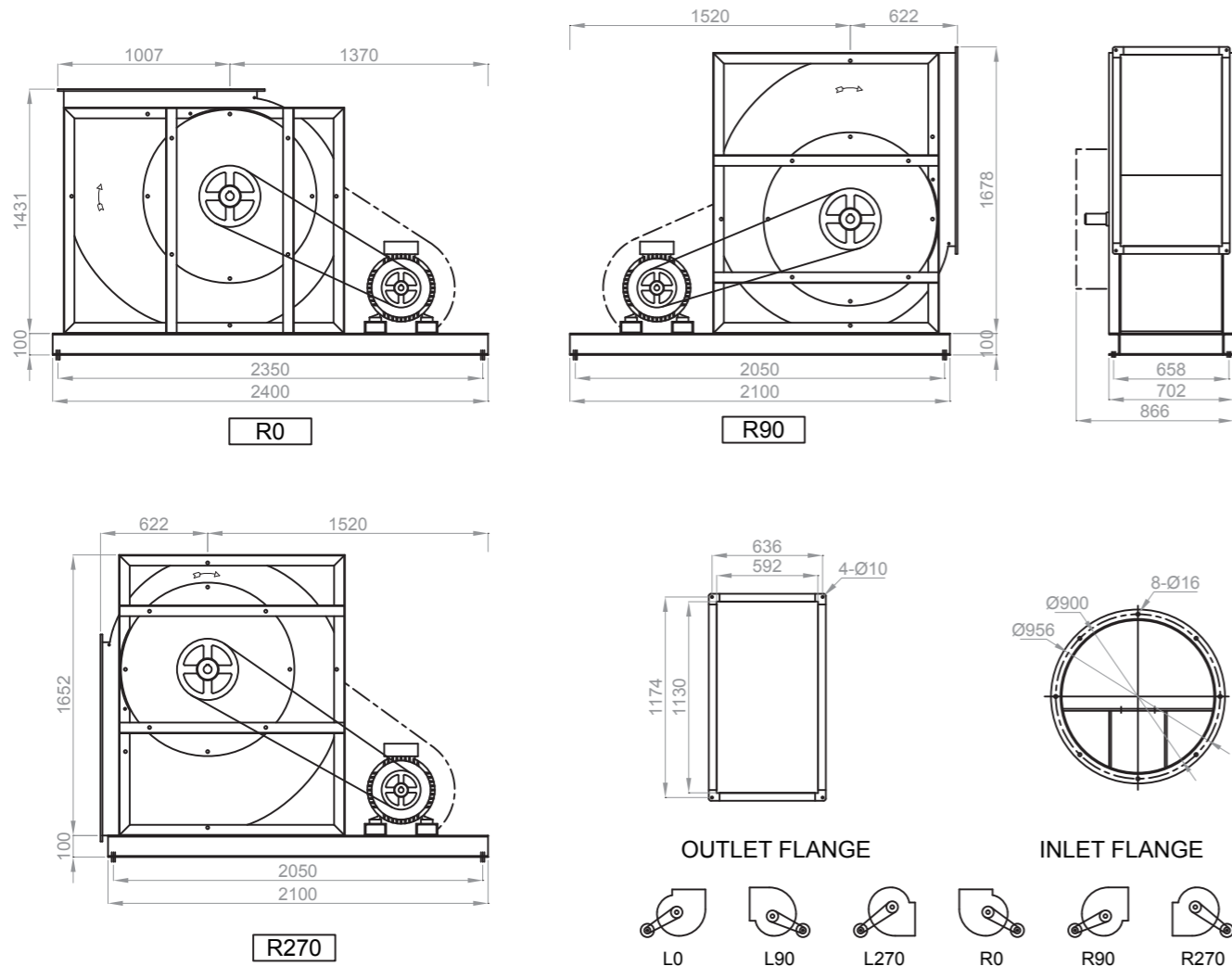

*Refer to page 42 for dimensions and weight of WFS 900 Overhung Type.

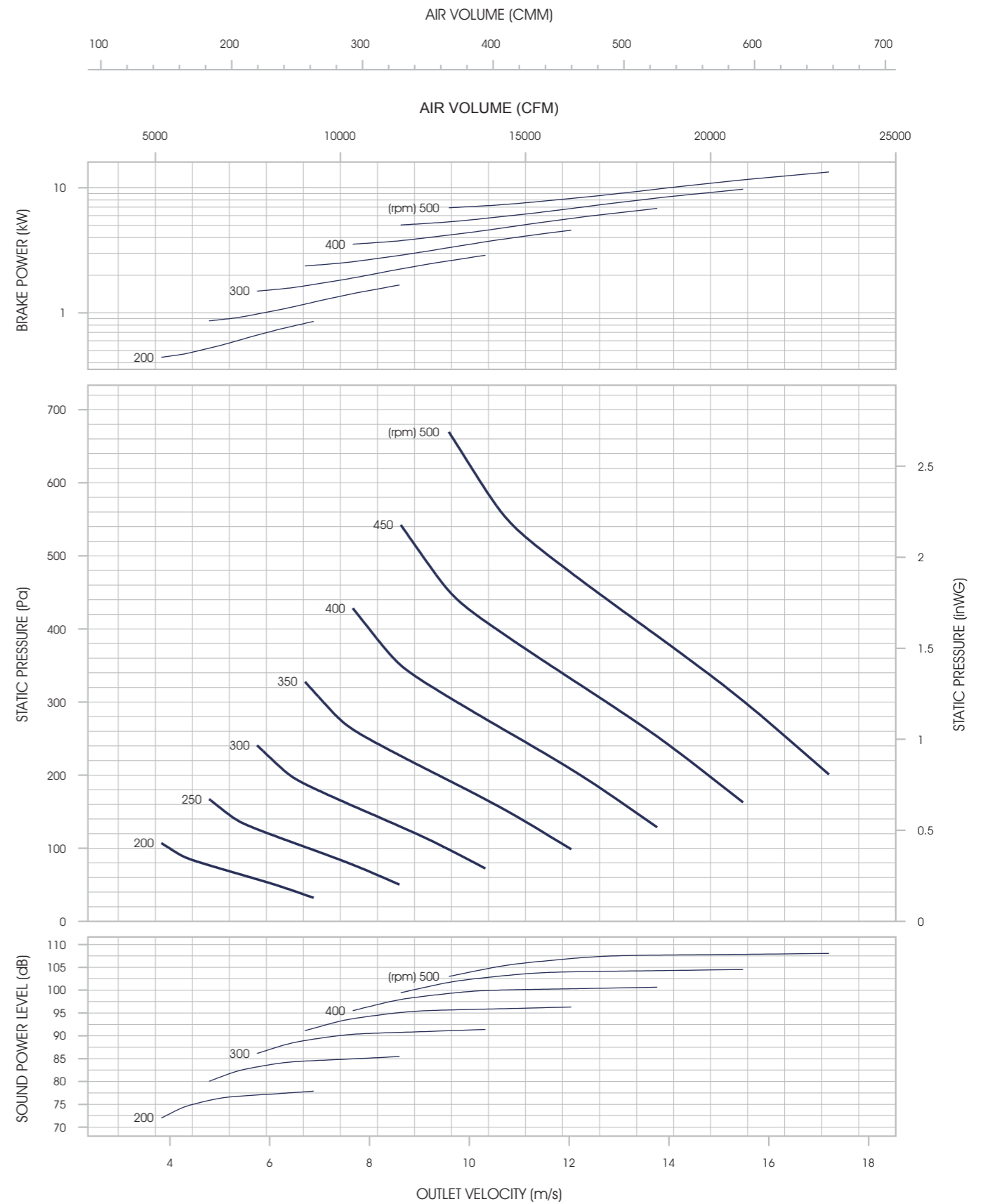

- 1) Power rating (B.kW) does not include transmission loss.
- 2) Performance ratings do not include the effects of appurtenances (accessories).
- 3) Performance certified is for installation type B - Free inlet, Ducted outlet.
- 4) The sound power level ratings shown are in decibels, referred to 10⁻¹² watts, calculated per AMCA International Standard 301.
- 5) Values shown are for inlet LWi sound power levels for Installation Type B: free inlet, ducted outlet.

WFS 1000

Forward Curved Single Inlet SWSI



Wheel Diameter 1000 mm.
Outlet Area 0.8186 m²
Material Casing: Galvanised Steel
 Impeller: Galvanised Steel
 Inlet Cone: Polyamide FRP
Rotation Forward

Motor (kW)	0.37	0.75	1.5	2.2	3.7	5.5	7.5	11	15	18.5	22
Motor Weight (kg)	8.5	11	20	24	40	49	54	100	125	160	180
Fan Weight (kg)	-	-	-	379	379	379	379	379	379	379	-
Total Weight (kg)	-	-	-	403	419	428	433	479	504	539	-

Unit : mm

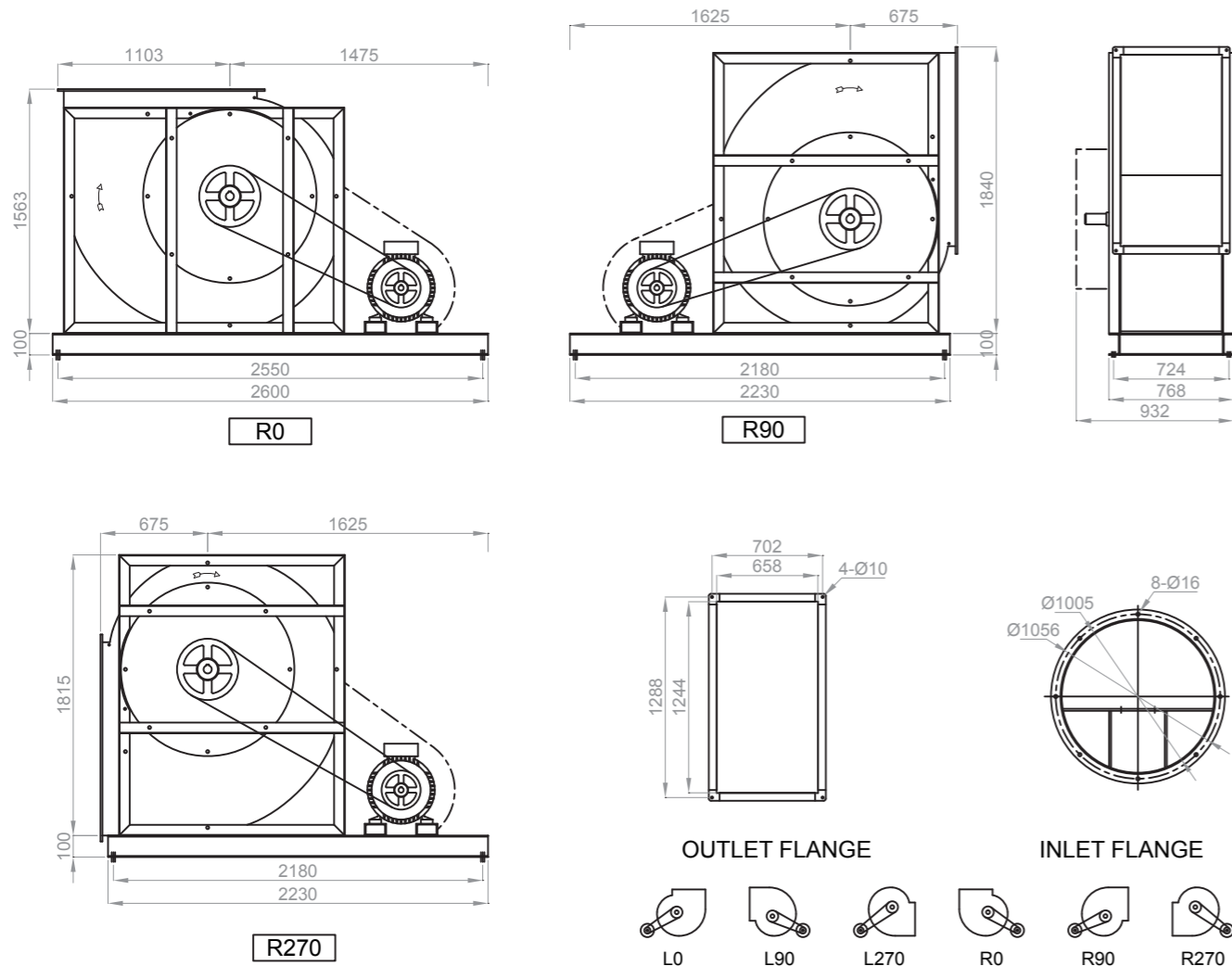

*Refer to page 42 for dimensions and weight of WFS 1000 Overhung Type.

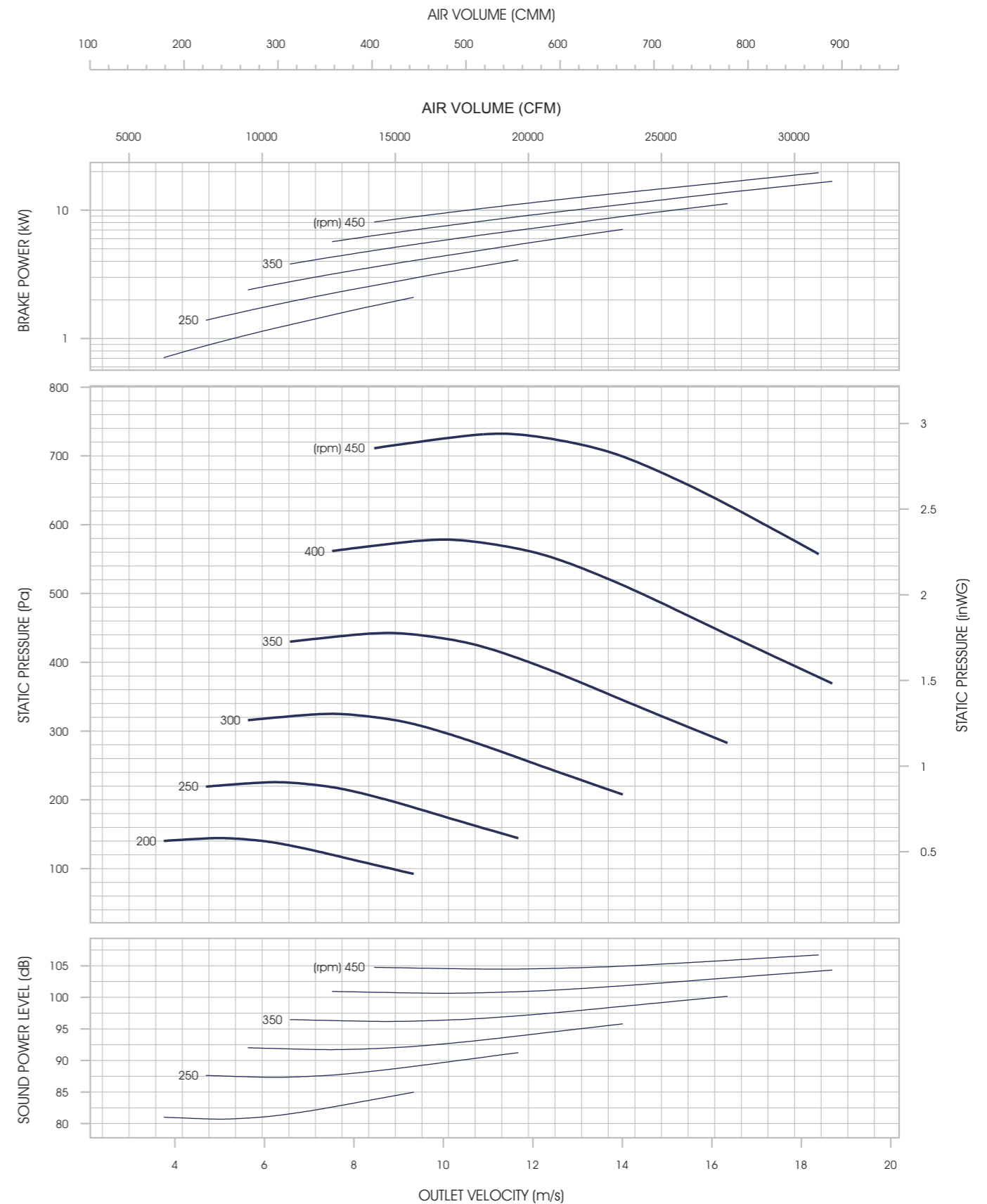

- 1) Power rating (B.kW) does not include transmission loss.
- 2) Performance ratings do not include the effects of appurtenances (accessories).
- 3) Performance certified is for installation type B - Free inlet, Ducted outlet.
- 4) The sound power level ratings shown are in decibels, referred to 10⁻¹² watts, calculated per AMCA International Standard 301.
- 5) Values shown are for inlet LWI sound power levels for Installation Type B: free inlet, ducted outlet.

DIMENSIONS & WEIGHT

Forward Curved Single Inlet SWSI - Overhung Type

Model No.	A1	A2	B1	B2	C1	C2	ØD1	ØD2	n-ØD3	n-ØD4	n-ØD5
WFS 225-O	590	520	160	200	390	423	225	259	3-12	3-8	4-10
WFS 250-O	650	580	175	220	425	458	250	286	3-12	3-8	4-10
WFS 280-O	690	620	197	230	457	500	280	320	3-16	3-10	4-10
WFS 315-O	740	670	218	250	498	541	315	356	3-16	3-10	4-10
WFS 355-O	810	740	246	290	566	619	355	395	4-16	4-10	4-10

Model No.	E1	E2	F1	F2	G	H1	H2	H3	I1	I2	J
WFS 225-O	147	191	280	324	108	317	372	380	280	191	450
WFS 250-O	162	206	312	356	108	354	416	425	306	207	497
WFS 280-O	184	228	350	394	110	397	469	477	347	225	515
WFS 315-O	205	249	394	438	130	430	512	520	377	247	550
WFS 355-O	233	277	444	488	130	490	585	593	420	272	597

Model No.	MOTOR (kW)	0.37	0.75	1.5	2.2	3.7	5.5	7.5	11	15	18.5	22
WFS 225-O	WEIGHT (kg)	8.5	11	20	24	40	49	54	100	125	160	180
WFS 225-O	22	30.5	33	42	-	-	-	-	-	-	-	-
WFS 250-O	28	36.5	39	48	-	-	-	-	-	-	-	-
WFS 280-O	32	40.5	43	52	56	-	-	-	-	-	-	-
WFS 315-O	38	46.5	49	58	62	-	-	-	-	-	-	-
WFS 355-O	48	56.5	59	68	72	88	-	-	-	-	-	-

Unit : mm

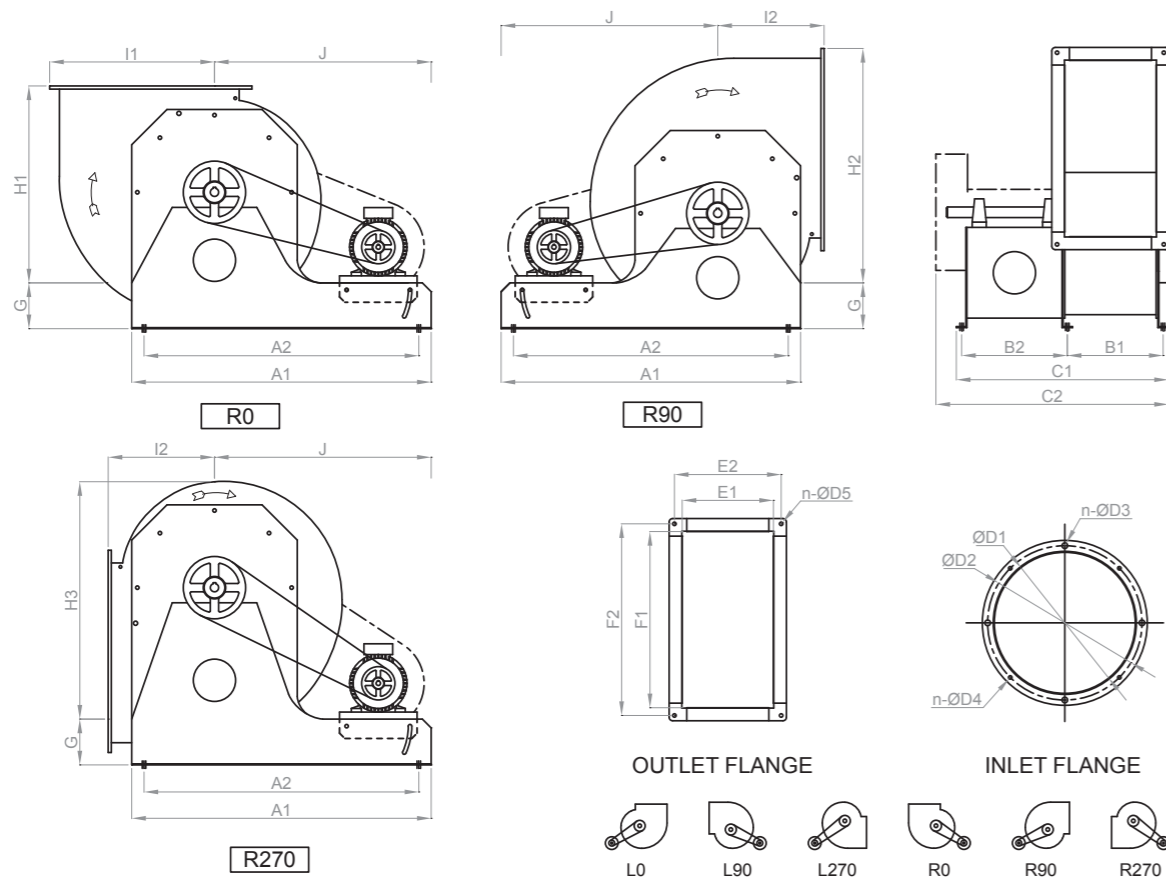

Model No.	A1	A2	B1	B2	C1	C2	ØD1	ØD2	n-ØD3	n-ØD4	n-ØD5
WFS 400-O	850	780	272	300	602	655	400	438	4-16	4-10	4-10
WFS 450-O	980	910	306	350	686	749	450	487	4-16	4-10	4-10
WFS 500-O	1050	980	339	375	744	807	500	541	4-16	4-10	4-10
WFS 560-O	1150	1070	382	440	862	936	560	605	4-20	4-14	4-10
WFS 630-O	1250	1170	428	440	908	982	630	674	4-20	4-14	4-10

Model No.	E1	E2	F1	F2	G	H1	H2	H3	I1	I2	J
WFS 400-O	259	303	500	544	130	559	665	674	468	302	615
WFS 450-O	293	337	560	604	190	575	697	705	522	333	720
WFS 500-O	326	370	626	670	193	648	786	794	575	363	760
WFS 560-O	368	412	700	744	204	733	885	893	640	405	820
WFS 630-O	414	458	788	832	204	839	1012	1020	715	449	885

Model No.	MOTOR (kW)	0.37	0.75	1.5	2.2	3.7	5.5	7.5	11	15	18.5	22
WFS 400-O	WEIGHT (kg)	8.5	11	20	24	40	49	54	100	125	160	180
WFS 400-O	65	73.5	76	85	89	105	-	-	-	-	-	-
WFS 450-O	71	-	82	91	95	111	-	-	-	-	-	-
WFS 500-O	118	-	129	138	142	158	167	-	-	-	-	-
WFS 560-O	157	-	168	177	181	197	206	-	-	-	-	-
WFS 630-O	180	-	-	200	204	220	229	234	-	-	-	-

Unit : mm

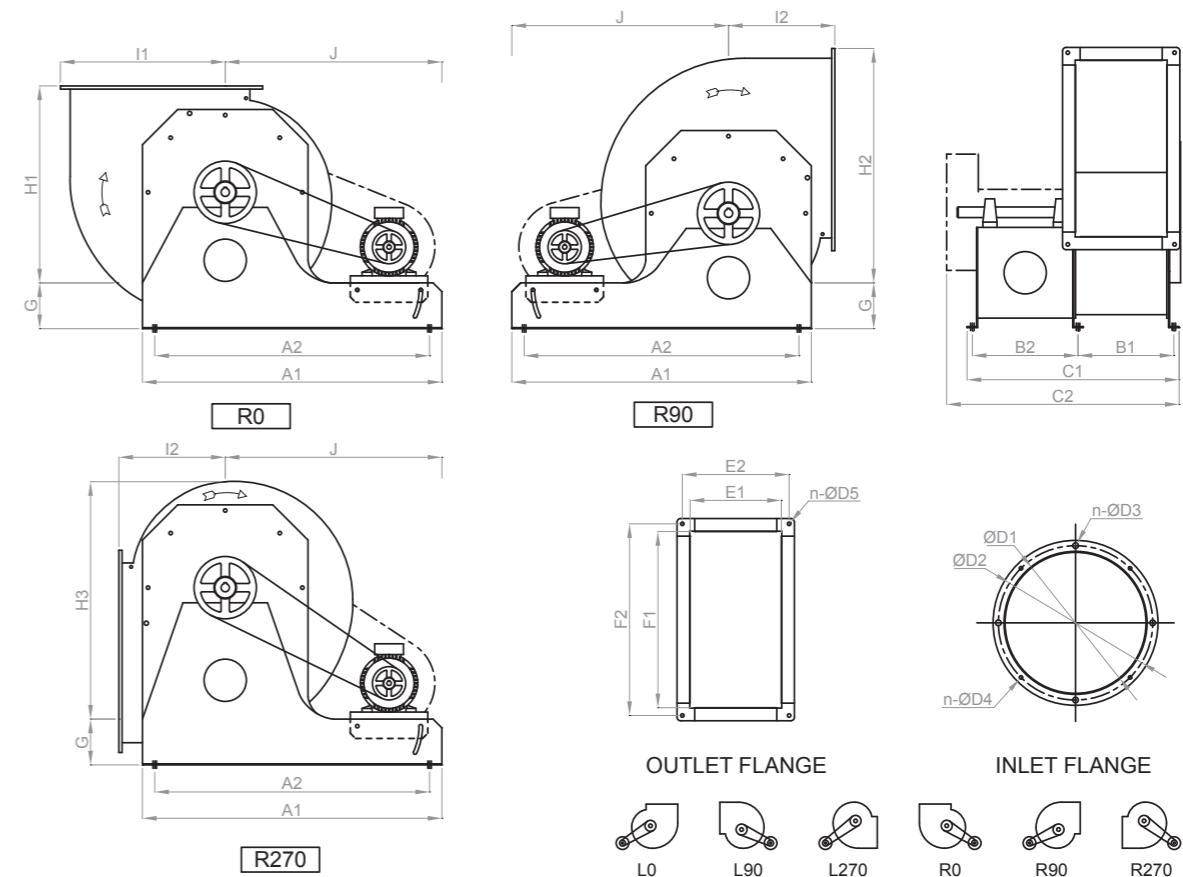

DIMENSIONS & WEIGHT

Forward Curved Single Inlet SWSI - Overhung Type

Model No.	A1	A2	A3	A4	B1	B2	C1	C2	ØD1	ØD2	n-ØD3	n-ØD4
WFS 710-O	1940	1890	1700	1650	537	405	986	1116	710	766	8-16	4-10
WFS 800-O	2100	2050	1800	1750	595	445	1084	1211	800	856	8-16	4-10
WFS 900-O	2300	2250	1960	1910	658	530	1232	1371	900	956	8-16	4-10
WFS 1000-O	2500	2450	2130	2080	724	620	1388	1524	1005	1056	8-16	4-10

Model No.	E1	E2	F1	F2	G	H1	H2	H3	I1	I2	J1	J2
WFS 710-O	471	515	890	934	100	1138	1335	1307	802	499	1116	1237
WFS 800-O	529	573	1000	1044	100	1276	1495	1473	898	558	1174	1295
WFS 900-O	592	636	1130	1174	100	1431	1678	1652	1007	622	1269	1400
WFS 1000-O	658	702	1244	1288	100	1563	1840	1815	1103	675	1372	1522

Model No.	MOTOR (kW)	0.37	0.75	1.5	2.2	3.7	5.5	7.5	11	15	18.5	22
WFS 710-O	WEIGHT (kg)	8.5	11	20	24	40	49	54	100	125	160	180
WFS 710-O	315	-	-	335	339	355	364	369	415	-	-	-
WFS 800-O	393	-	-	413	417	433	442	447	493	518	-	-
WFS 900-O	488	-	-	-	512	528	537	542	588	613	-	-
WFS 1000-O	556	-	-	-	580	596	605	610	656	681	716	-

Unit : mm

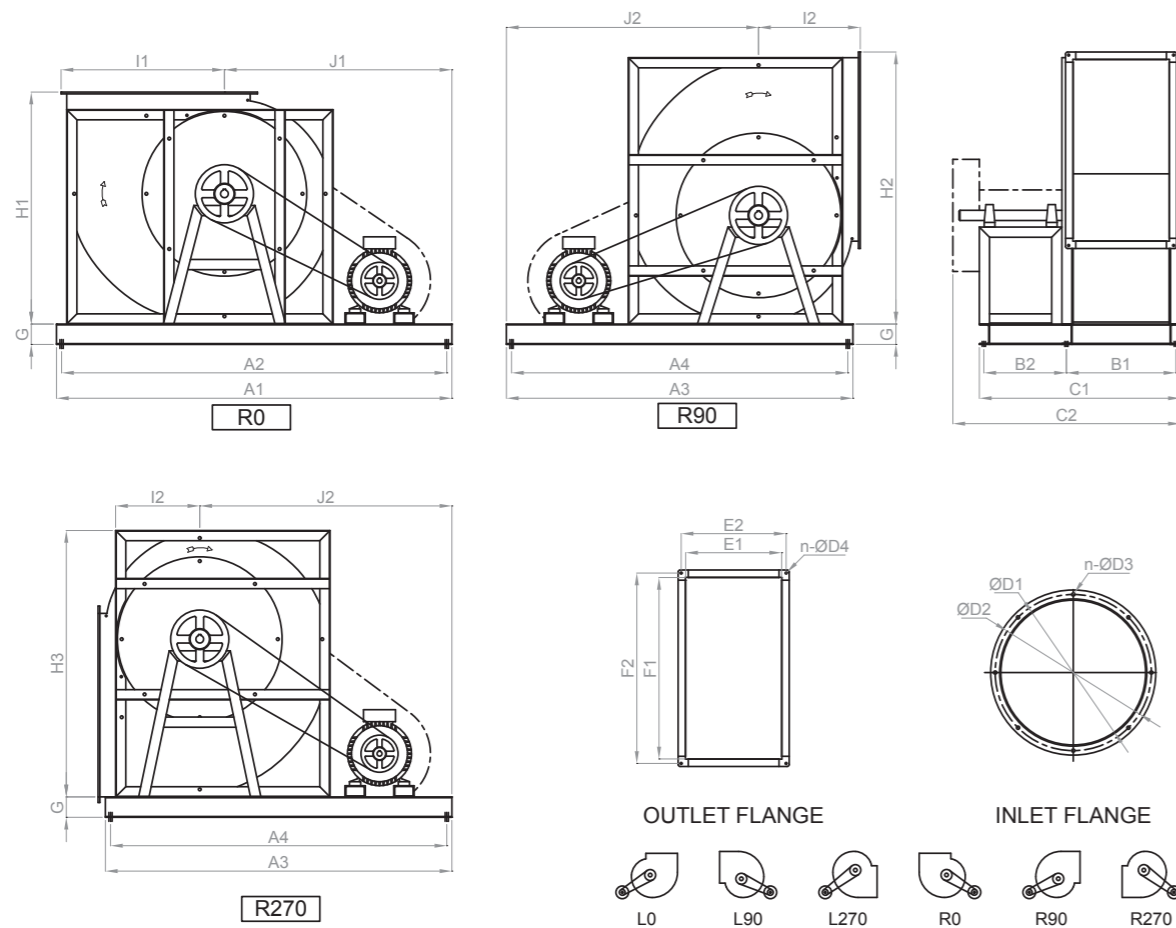

Backward Curved Single Inlet SWSI

WBS 280-1000

*Overhung Type Centrifugal Fan Curves are as same as those of the standard Centrifugal



WBS 280

Backward Curved Single Inlet SWSI



Wheel Diameter 280 mm.
Outlet Area 0.0644 m²
Material Casing: Galvanised Steel
 Impeller: Aluminum
 Inlet Cone: Polyamide FRP
Rotation Backward

Motor (kW)	0.37	0.75	1.5	2.2	3.7	5.5	7.5	11	15	18.5	22
Motor Weight (kg)	8.5	11	20	24	40	49	54	100	125	160	180
Fan Weight (kg)	25	25	25	25	-	-	-	-	-	-	-
Total Weight (kg)	33.5	36	45	49	-	-	-	-	-	-	-

Unit : mm

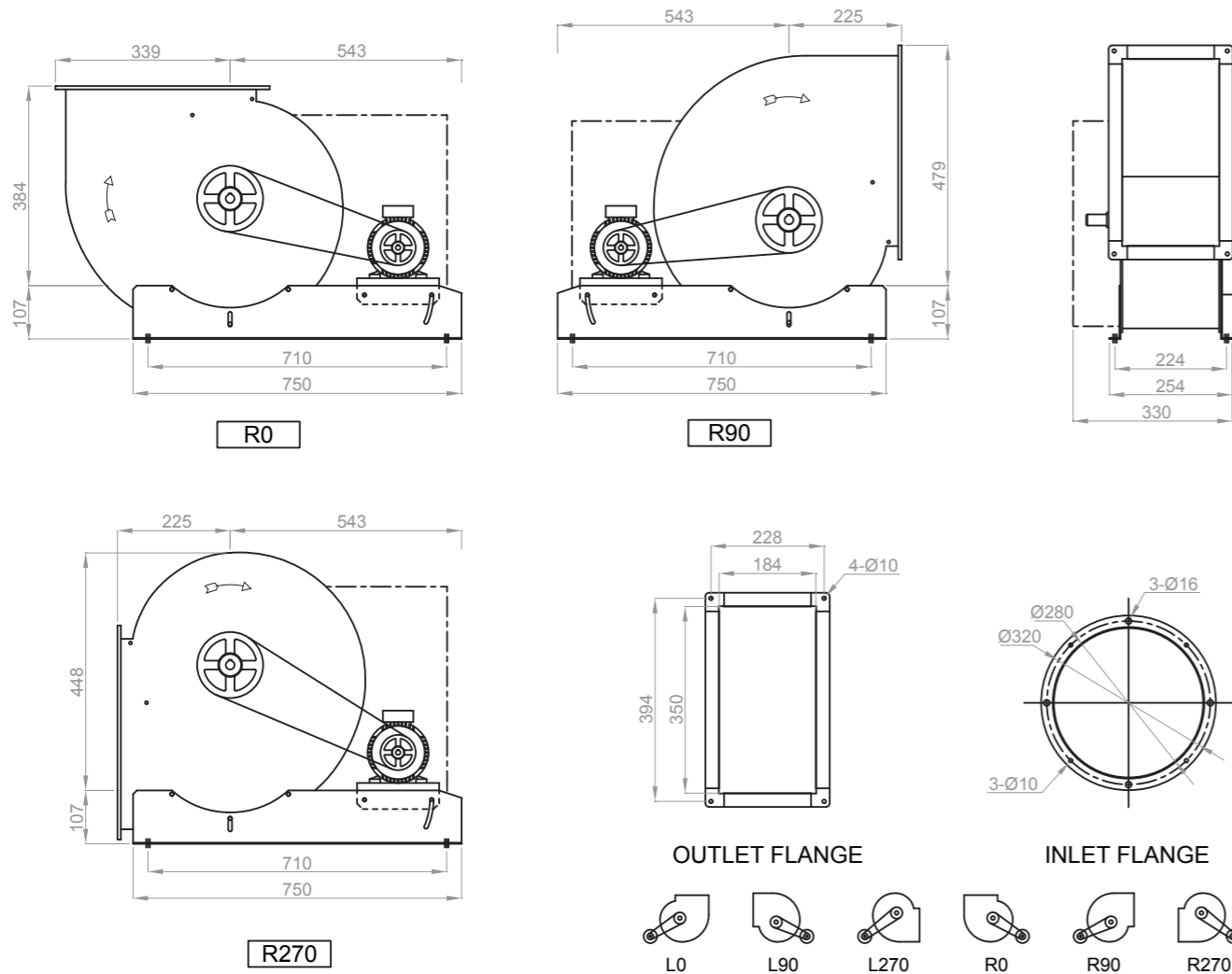

*Refer to page 68 for dimensions and weight of WBS 280 Overhung Type.

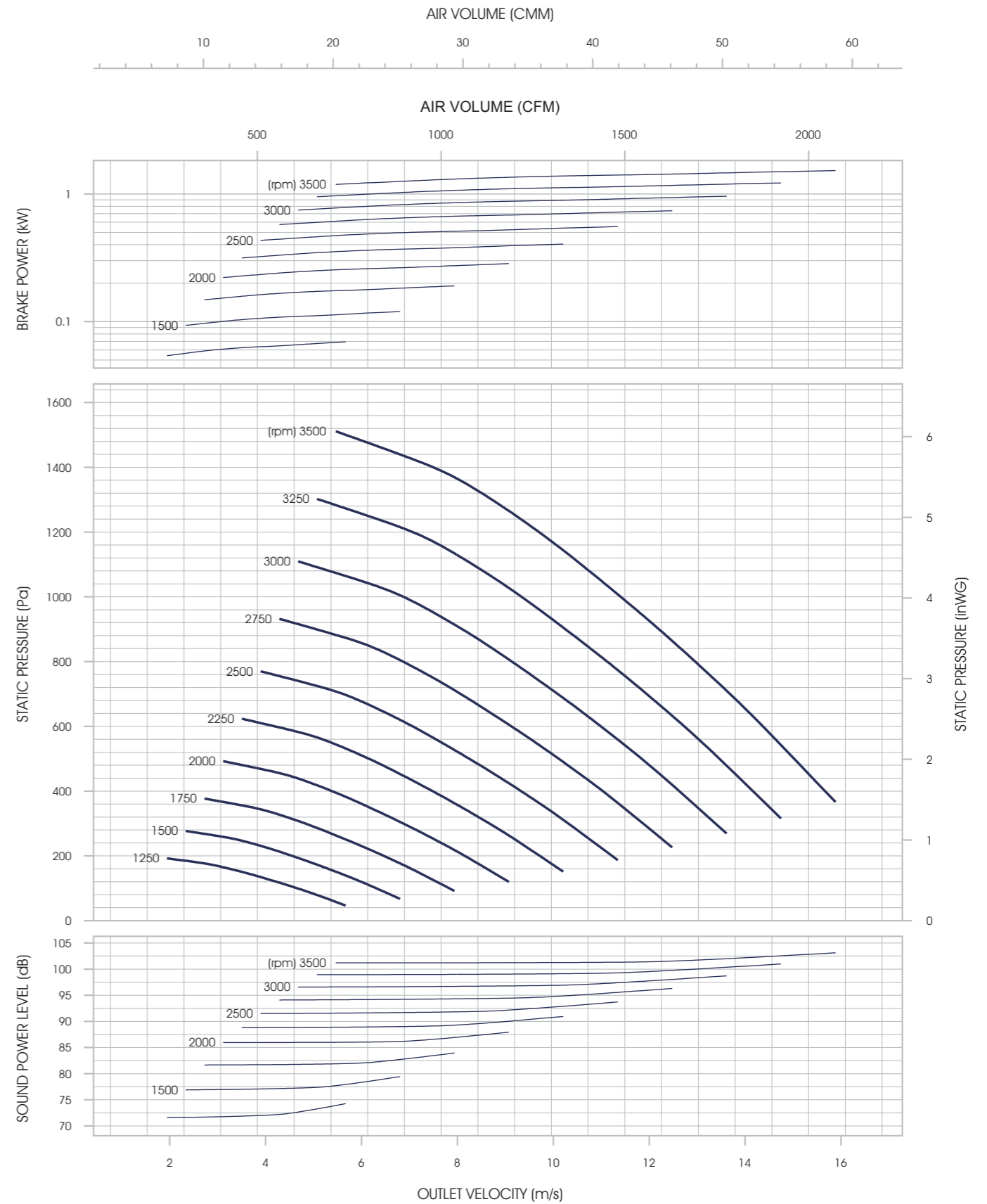

- 1) Power rating (B.KW) does not include transmission loss.
- 2) Performance ratings do not include the effects of appurtenances (accessories).
- 3) Performance certified is for installation type B - Free inlet, Ducted outlet.
- 4) The sound power level ratings shown are in decibels, referred to 10⁻¹² watts, calculated per AMCA International Standard 301.
- 5) Values shown are for inlet LWi sound power levels for Installation Type B: free inlet, ducted outlet.

WBS 315

Backward Curved Single Inlet SWSI



Wheel Diameter 315 mm.
Outlet Area 0.0808 m²
Material Casing: Galvanised Steel
 Impeller: Aluminum
 Inlet Cone: Polyamide FRP
Rotation Backward

Motor (kW)	0.37	0.75	1.5	2.2	3.7	5.5	7.5	11	15	18.5	22
Motor Weight (kg)	8.5	11	20	24	40	49	54	100	125	160	180
Fan Weight (kg)	26	26	26	26	-	-	-	-	-	-	-
Total Weight (kg)	34.5	37	46	50	-	-	-	-	-	-	-

Unit : mm

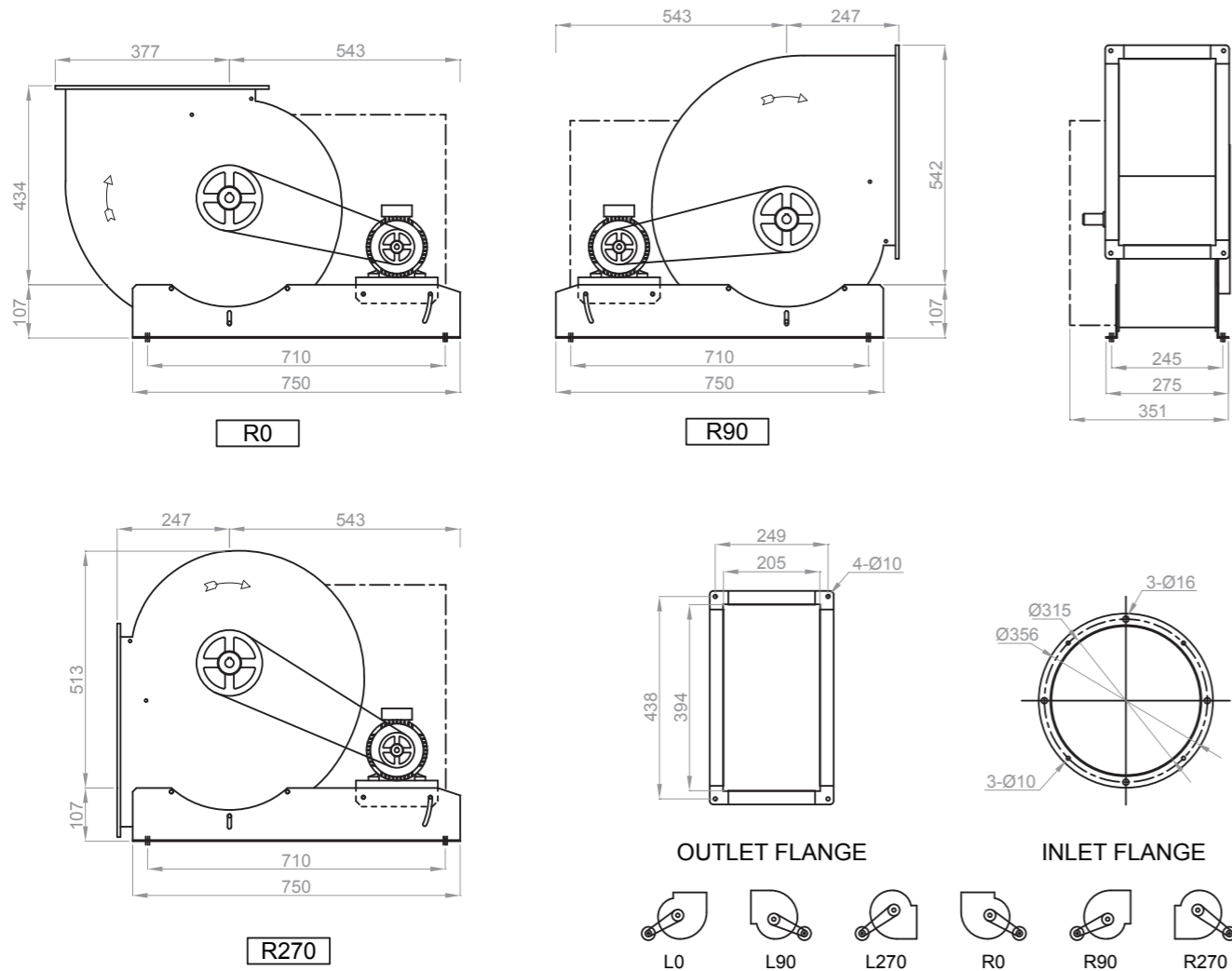

*Refer to page 68 for dimensions and weight of WBS 315 Overhung Type.

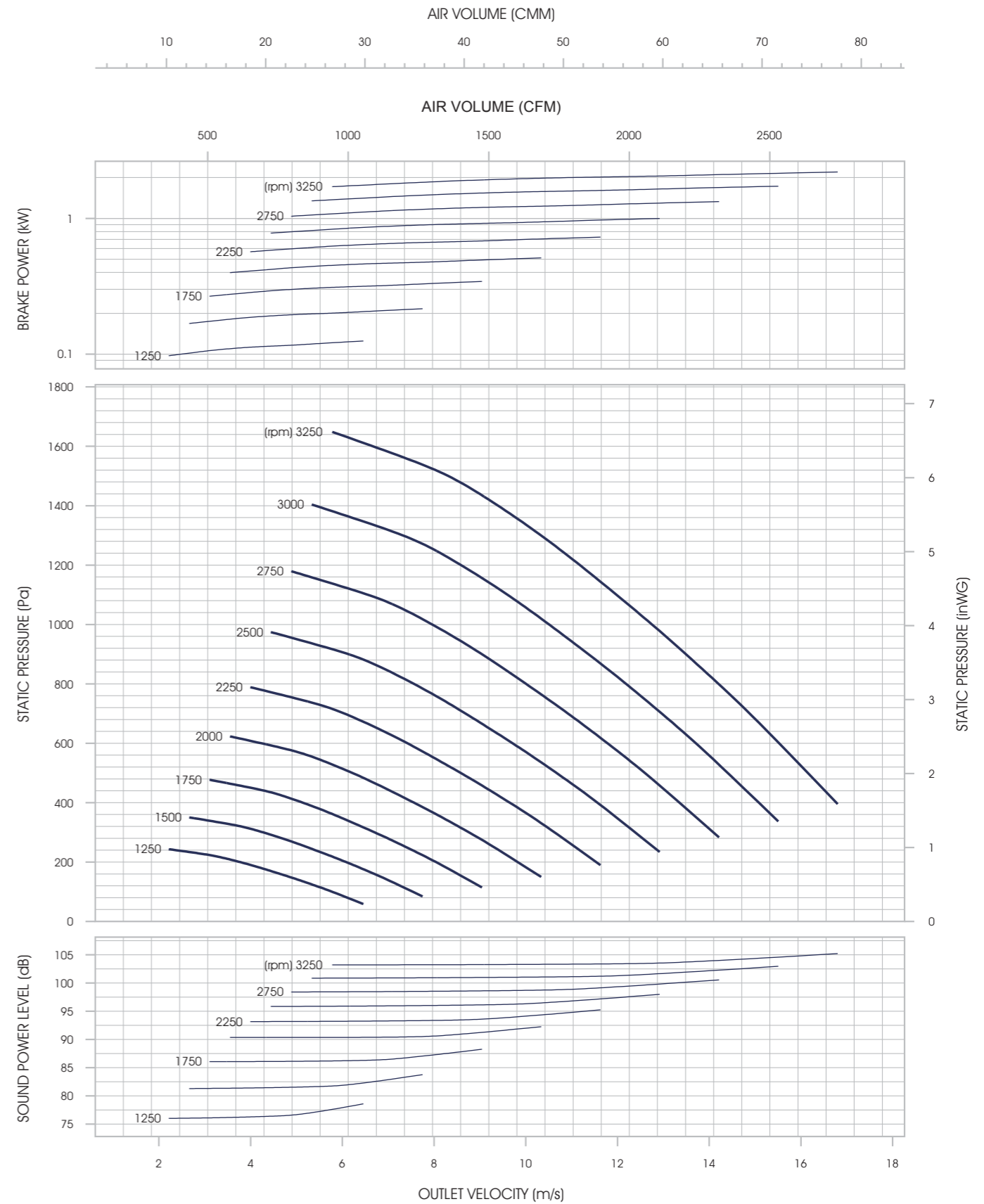

- 1) Power rating (B.KW) does not include transmission loss.
- 2) Performance ratings do not include the effects of appurtenances (accessories).
- 3) Performance certified is for installation type B - Free inlet, Ducted outlet.
- 4) The sound power level ratings shown are in decibels, referred to 10⁻¹² watts, calculated per AMCA International Standard 301.
- 5) Values shown are for inlet LWi sound power levels for Installation Type B: free inlet, ducted outlet.

WBS 355

Backward Curved Single Inlet SWSI



Wheel Diameter 355 mm.
Outlet Area 0.1035 m²
Material Casing: Galvanised Steel
 Impeller: Aluminum
 Inlet Cone: Polyamide FRP
Rotation Backward

Motor (kW)	0.37	0.75	1.5	2.2	3.7	5.5	7.5	11	15	18.5	22
Motor Weight (kg)	8.5	11	20	24	40	49	54	100	125	160	180
Fan Weight (kg)	42	42	42	42	42	-	-	-	-	-	-
Total Weight (kg)	50.5	53	62	66	82	-	-	-	-	-	-

Unit : mm

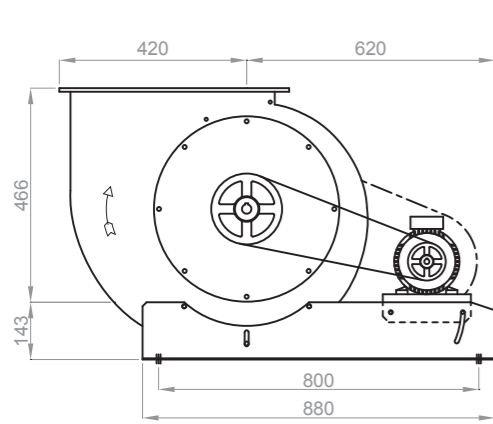

R0

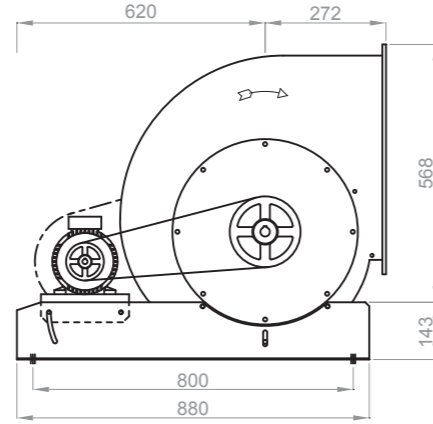

R90

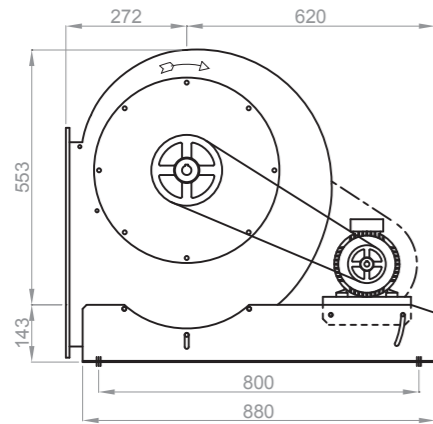
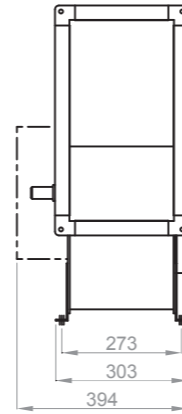

R270

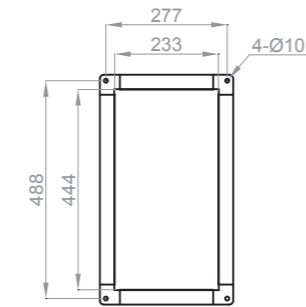

OUTLET FLANGE

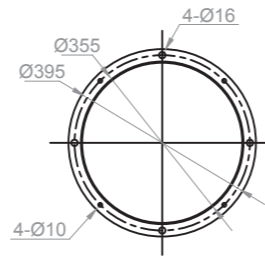

INLET FLANGE

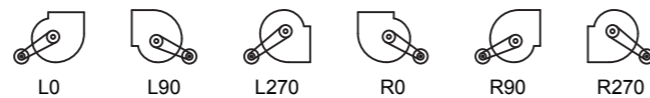

*Refer to page 68 for dimensions and weight of WBS 355 Overhung Type.

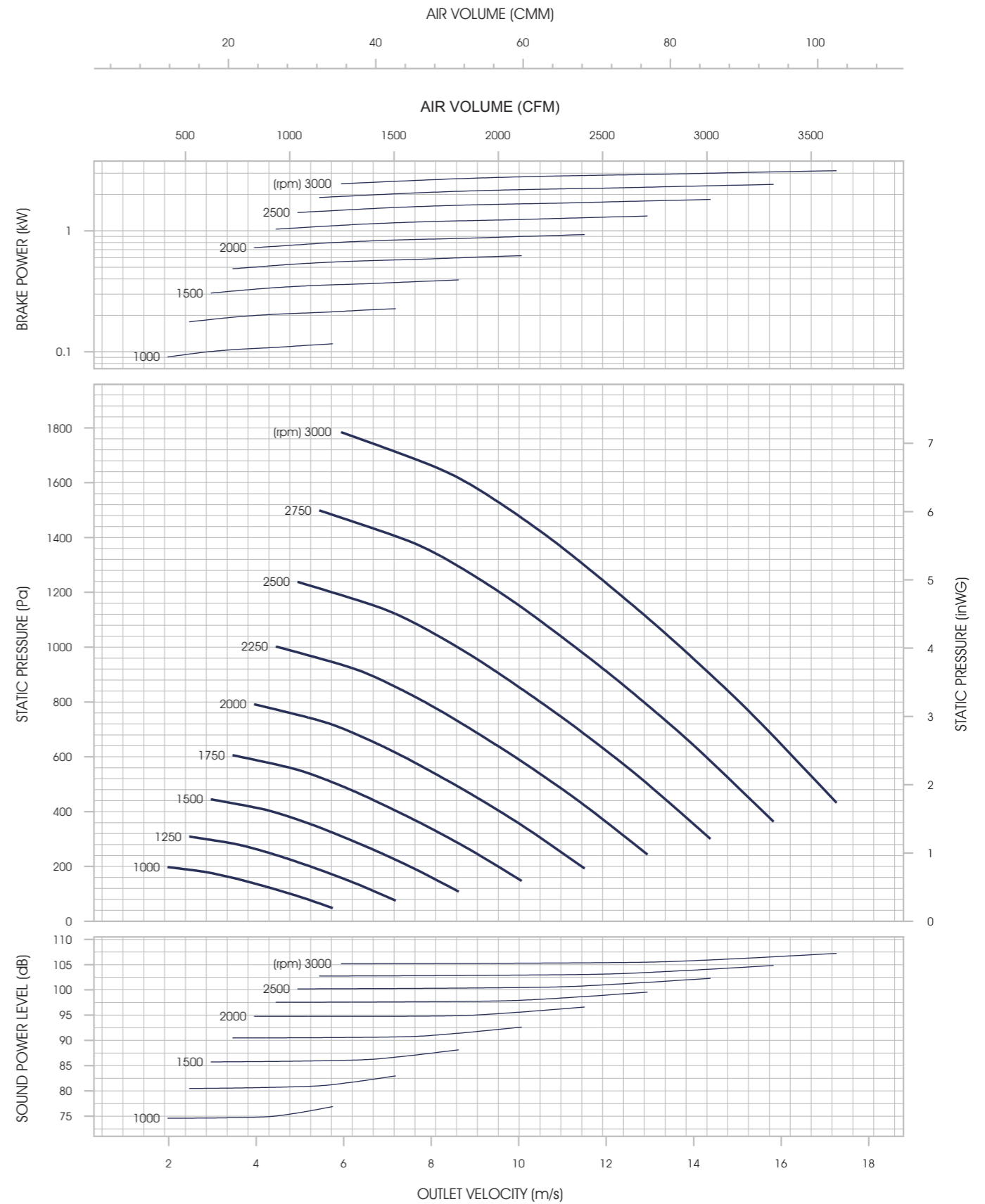

- 1) Power rating (B.kW) does not include transmission loss.
- 2) Performance ratings do not include the effects of appurtenances (accessories).
- 3) Performance certified is for installation type B - Free inlet, Ducted outlet.
- 4) The sound power level ratings shown are in decibels, referred to 10⁻¹² watts, calculated per AMCA International Standard 301.
- 5) Values shown are for inlet LWi sound power levels for Installation Type B: free inlet, ducted outlet.

WBS 400

Backward Curved Single Inlet SWSI



Wheel Diameter 400 mm.
Outlet Area 0.1295 m²
Material Casing: Galvanised Steel
 Impeller: Aluminum
 Inlet Cone: Polyamide FRP
Rotation Backward

Motor (kW)	0.37	0.75	1.5	2.2	3.7	5.5	7.5	11	15	18.5	22
Motor Weight (kg)	8.5	11	20	24	40	49	54	100	125	160	180
Fan Weight (kg)	44	44	44	44	44	-	-	-	-	-	-
Total Weight (kg)	52.5	55	64	68	84	-	-	-	-	-	-

Unit : mm

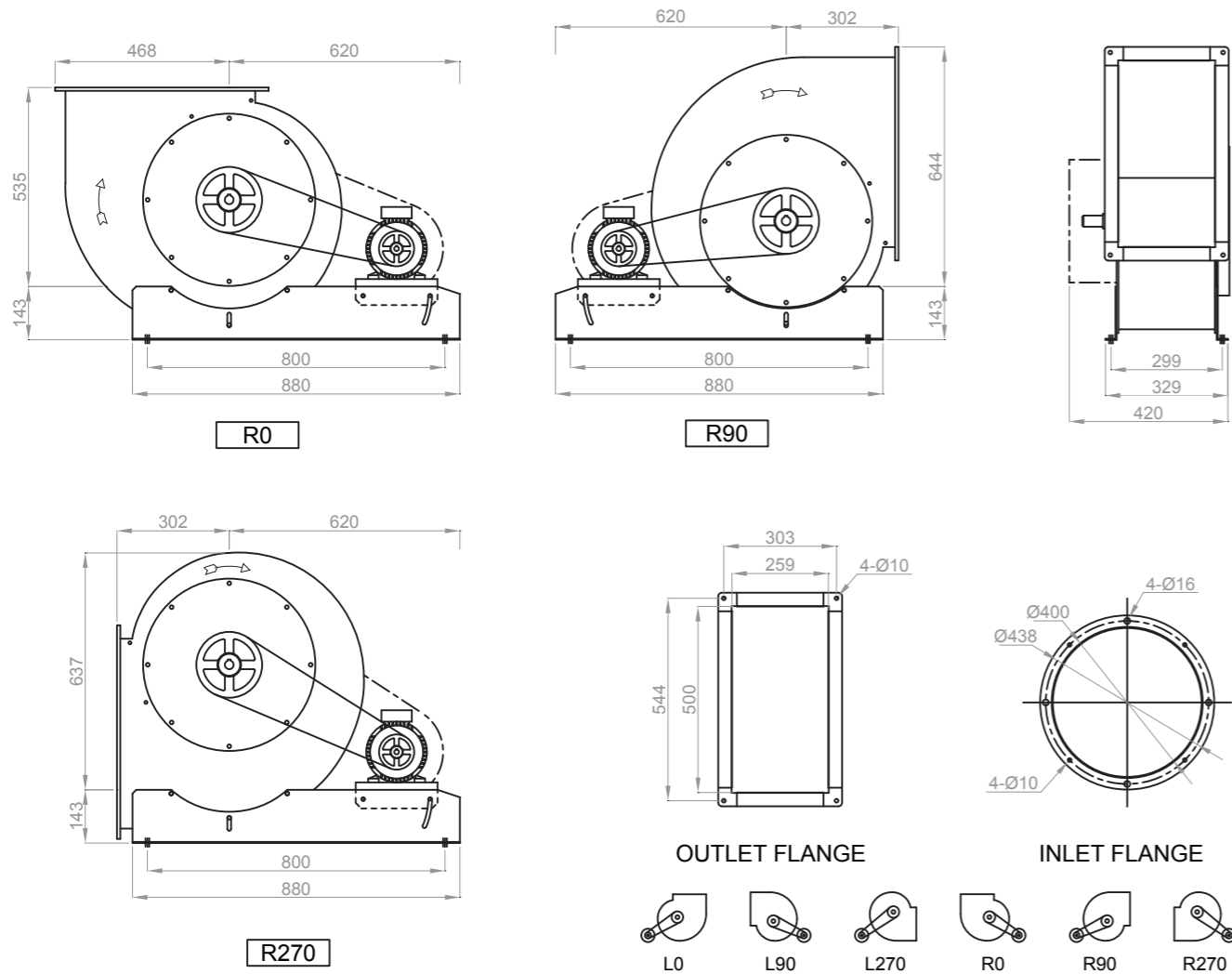

*Refer to page 68 for dimensions and weight of WBS 400 Overhung Type.

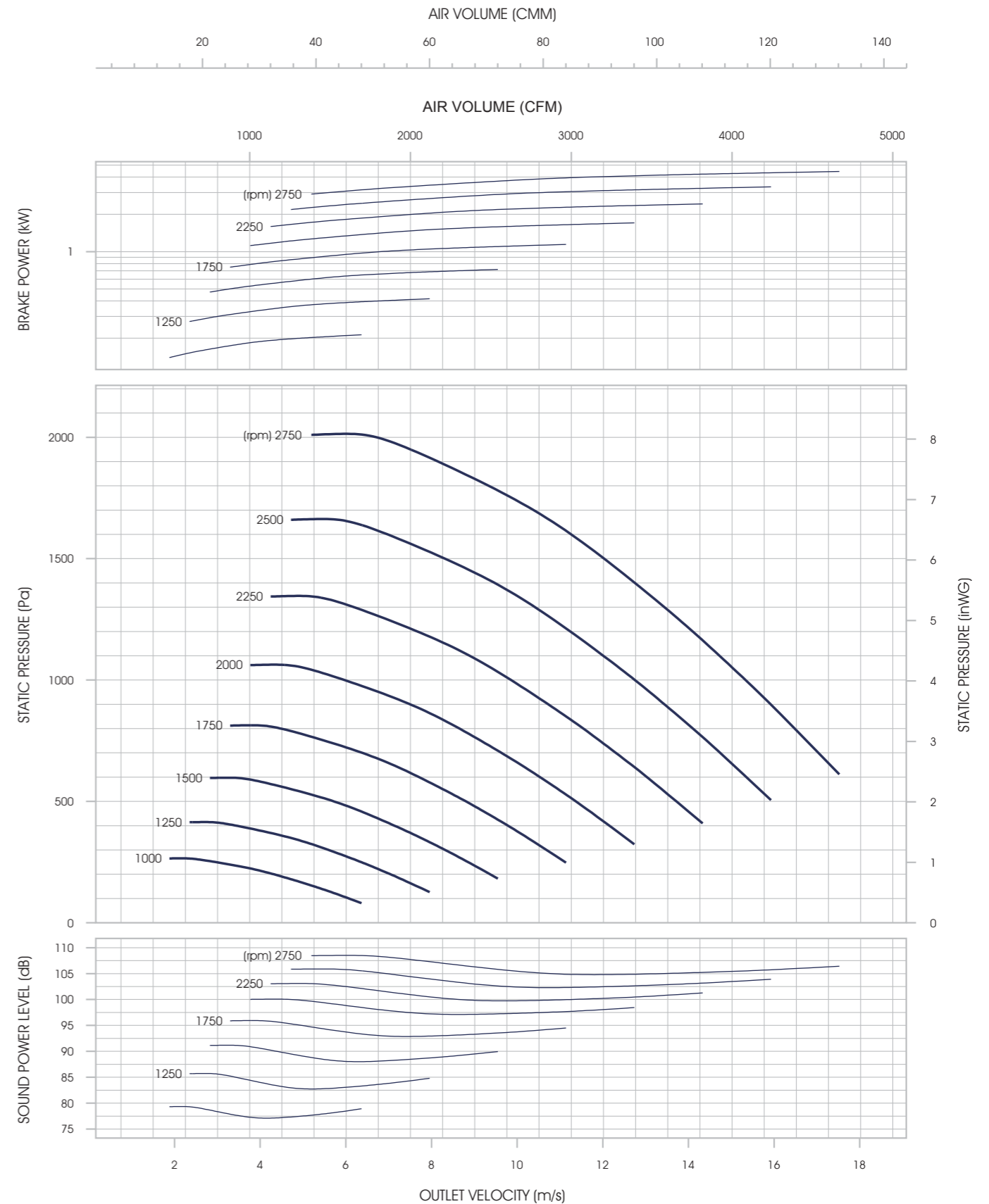

- 1) Power rating (B.kW) does not include transmission loss.
- 2) Performance ratings do not include the effects of appurtenances (accessories).
- 3) Performance certified is for installation type B - Free inlet, Ducted outlet.
- 4) The sound power level ratings shown are in decibels, referred to 10⁻¹² watts, calculated per AMCA International Standard 301.
- 5) Values shown are for inlet LWi sound power levels for Installation Type B: free inlet, ducted outlet.

WBS 450

Backward Curved Single Inlet SWSI



Wheel Diameter 450 mm.
Outlet Area 0.1641 m²
Material Casing: Galvanised Steel
 Impeller: Aluminum
 Inlet Cone: Polyamide FRP
Rotation Backward

Motor (kW)	0.37	0.75	1.5	2.2	3.7	5.5	7.5	11	15	18.5	22
Motor Weight (kg)	8.5	11	20	24	40	49	54	100	125	160	180
Fan Weight (kg)	-	61	61	61	61	61	-	-	-	-	-
Total Weight (kg)	-	72	81	85	101	110	-	-	-	-	-

Unit : mm

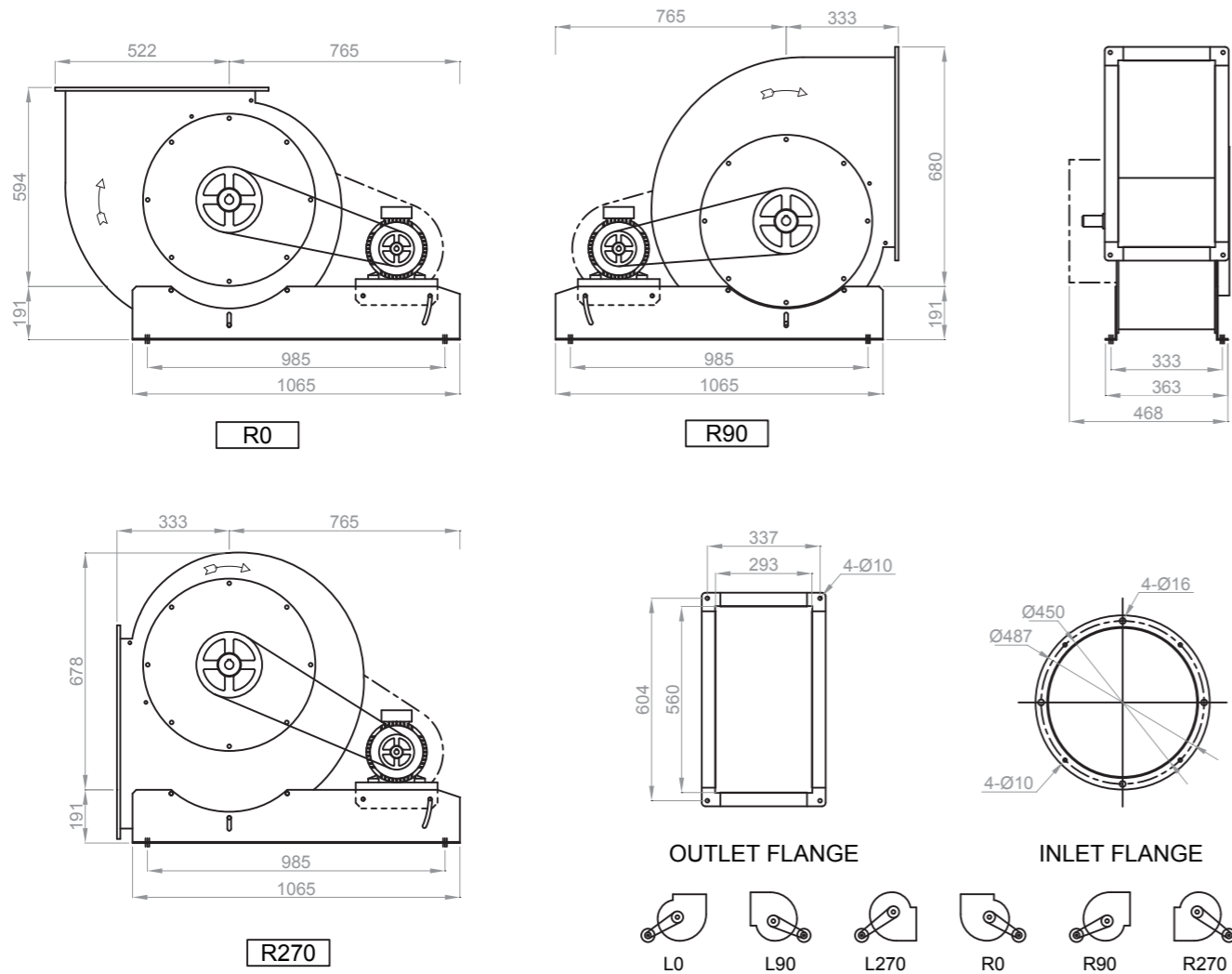

*Refer to page 69 for dimensions and weight of WBS 450 Overhung Type.

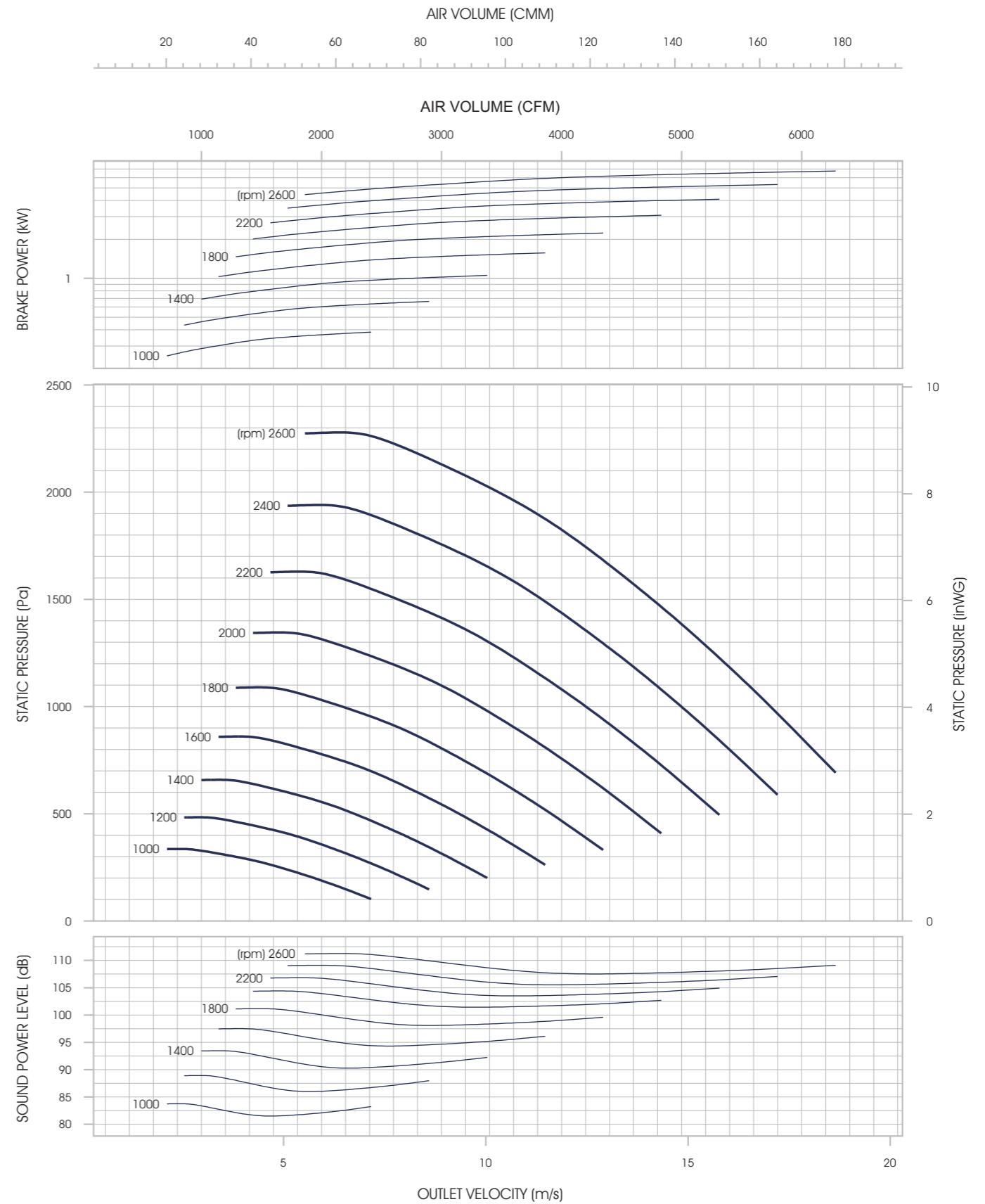

- 1) Power rating (B.KW) does not include transmission loss.
- 2) Performance ratings do not include the effects of appurtenances (accessories).
- 3) Performance certified is for installation type B - Free inlet, Ducted outlet.
- 4) The sound power level ratings shown are in decibels, referred to 10⁻¹² watts, calculated per AMCA International Standard 301.
- 5) Values shown are for inlet LWi sound power levels for Installation Type B: free inlet, ducted outlet.

WBS 500

Backward Curved Single Inlet SWSI



Wheel Diameter 500 mm.
Outlet Area 0.2041 m²
Material Casing: Galvanised Steel
 Impeller: Aluminum
 Inlet Cone: Polyamide FRP
Rotation Backward

Motor (kW)	0.37	0.75	1.5	2.2	3.7	5.5	7.5	11	15	18.5	22
Motor Weight (kg)	8.5	11	20	24	40	49	54	100	125	160	180
Fan Weight (kg)	-	73	73	73	73	73	73	-	-	-	-
Total Weight (kg)	-	84	93	97	113	122	127	-	-	-	-

Unit : mm

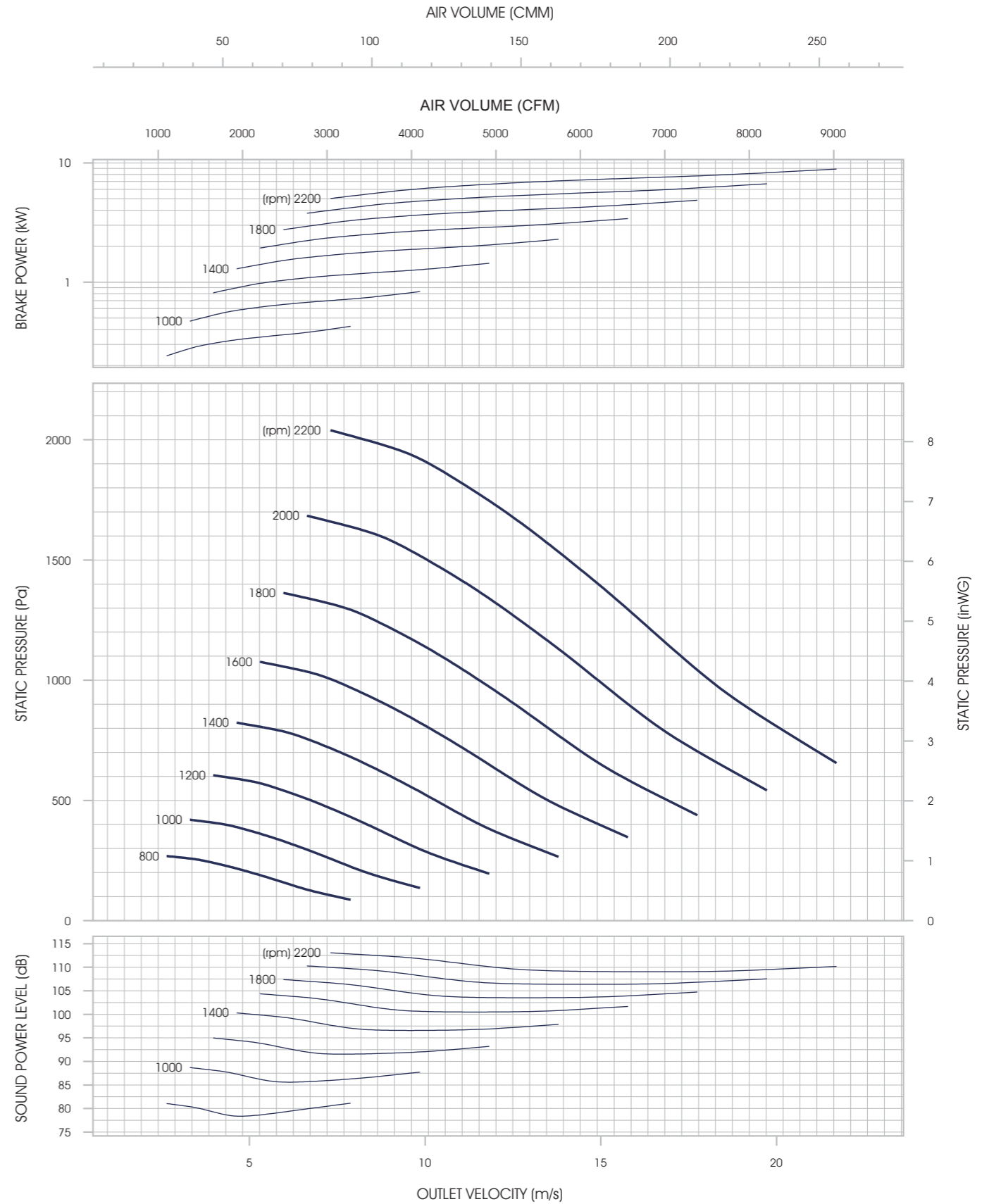
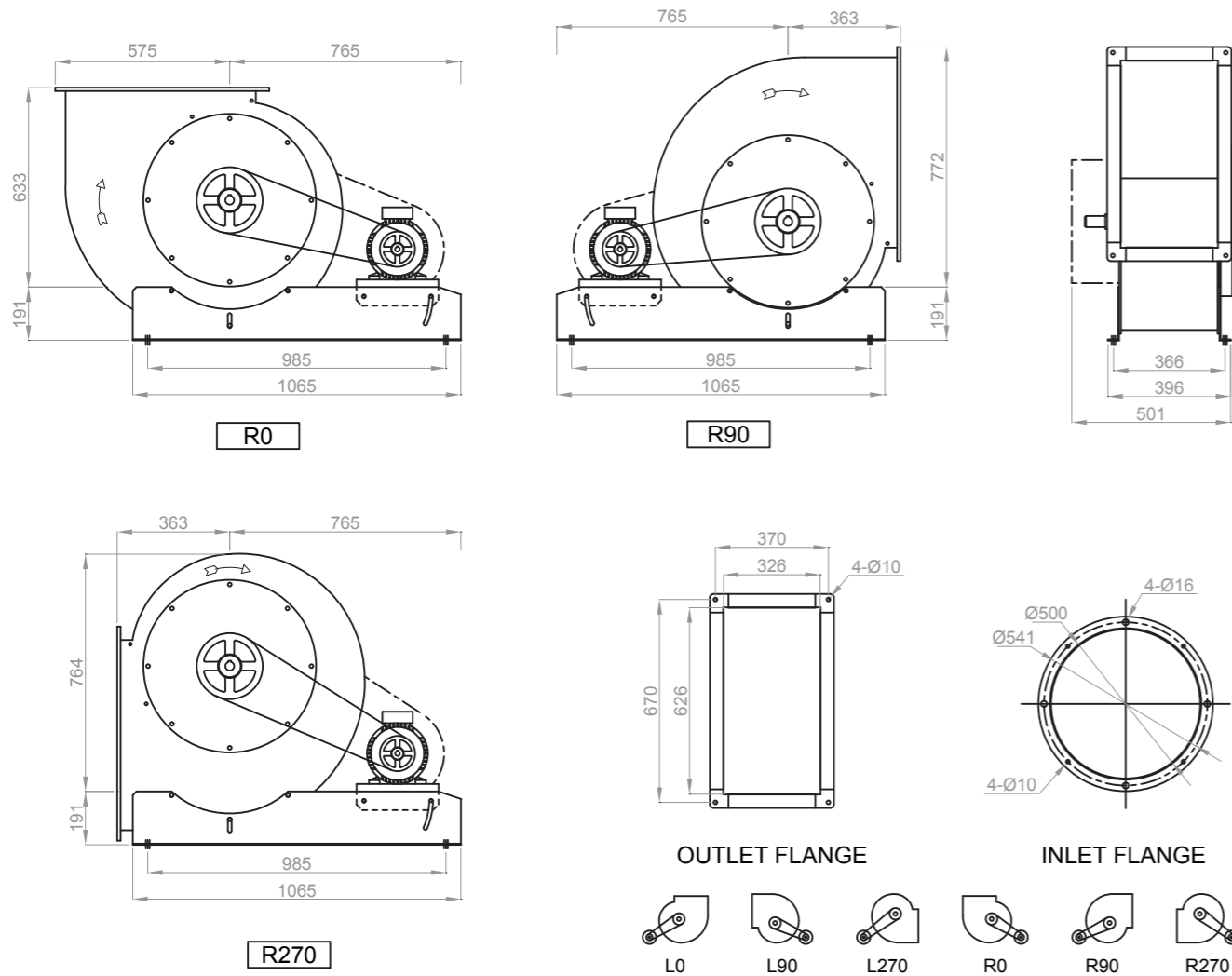

- 1) Power rating (B.KW) does not include transmission loss.
- 2) Performance ratings do not include the effects of appurtenances (accessories).
- 3) Performance certified is for installation type B - Free inlet, Ducted outlet.
- 4) The sound power level ratings shown are in decibels, referred to 10⁻¹² watts, calculated per AMCA International Standard 301.
- 5) Values shown are for inlet LWi sound power levels for Installation Type B: free inlet, ducted outlet.

*Refer to page 69 for dimensions and weight of WBS 500 Overhung Type.

WBS 560

Backward Curved Single Inlet SWSI

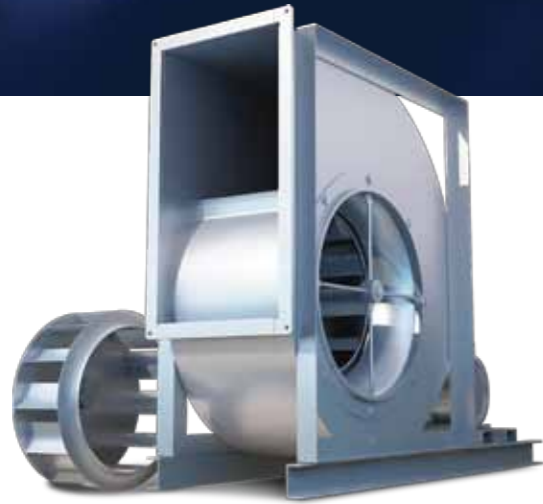

Wheel Diameter 560 mm.
Outlet Area 0.2576 m²
Material Casing: Galvanised Steel
 Impeller: Aluminum
 Inlet Cone: Polyamide FRP
Rotation Backward

Motor (kW)	0.37	0.75	1.5	2.2	3.7	5.5	7.5	11	15	18.5	22
Motor Weight (kg)	8.5	11	20	24	40	49	54	100	125	160	180
Fan Weight (kg)	-	122	122	122	122	122	122	122	-	-	-
Total Weight (kg)	-	133	142	146	162	171	176	222	-	-	-

Unit : mm

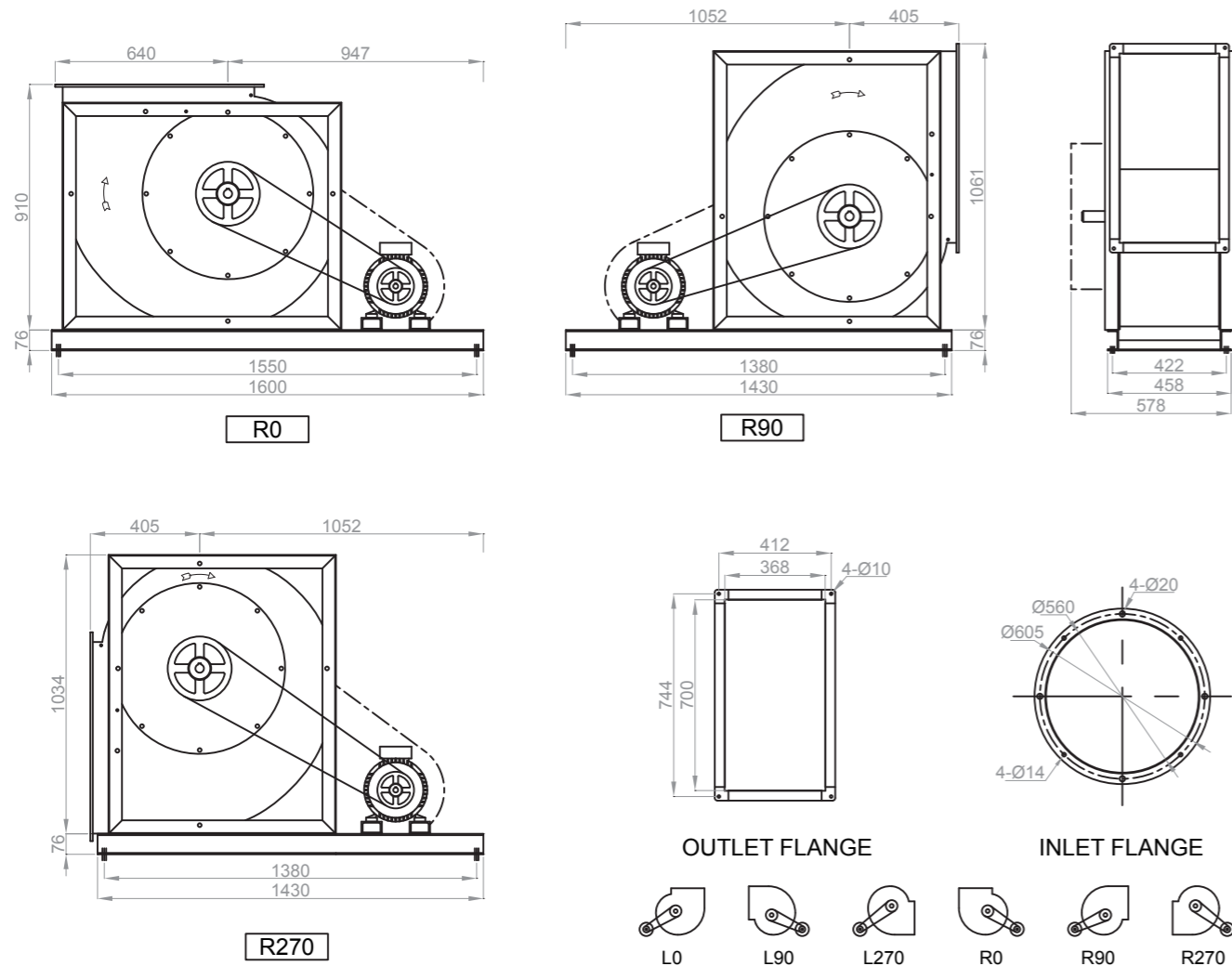

*Refer to page 69 for dimensions and weight of WBS 560 Overhung Type.

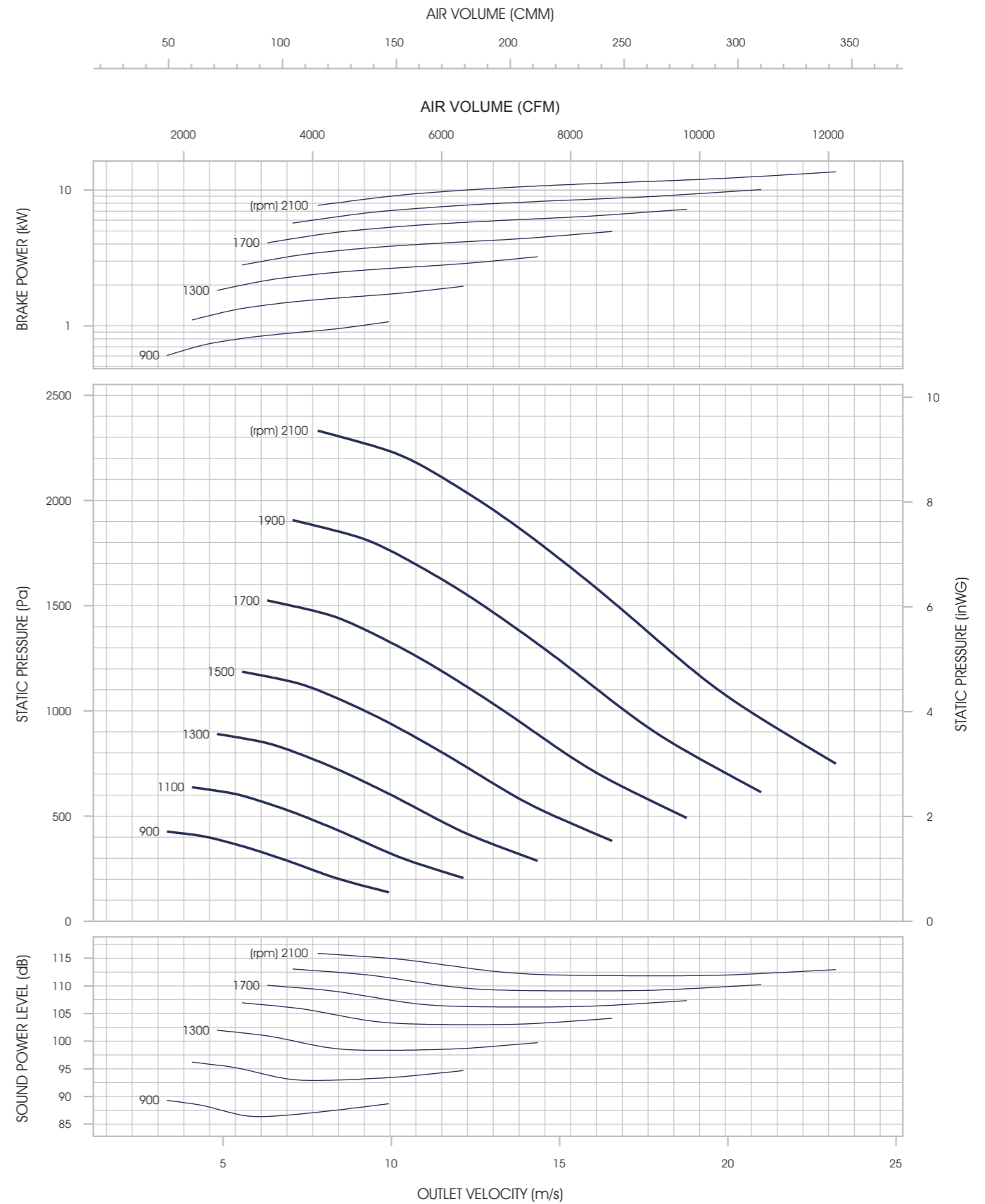

- 1) Power rating (B.kW) does not include transmission loss.
- 2) Performance ratings do not include the effects of appurtenances (accessories).
- 3) Performance certified is for installation type B - Free inlet, Ducted outlet.
- 4) The sound power level ratings shown are in decibels, referred to 10⁻¹² watts, calculated per AMCA International Standard 301.
- 5) Values shown are for inlet LWi sound power levels for Installation Type B: free inlet, ducted outlet.

WBS 630

Backward Curved Single Inlet SWSI

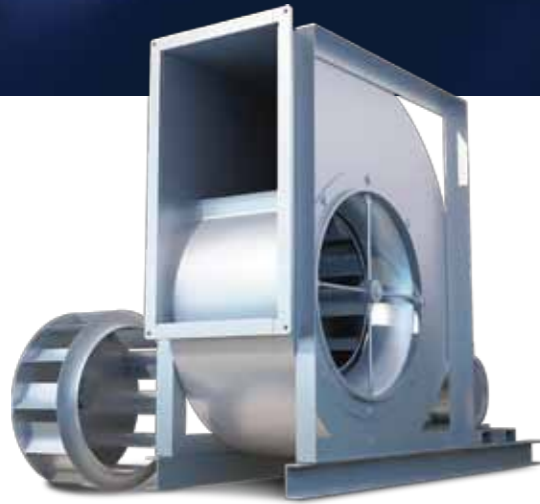

Wheel Diameter 630 mm.
Outlet Area 0.3262 m²
Material Casing: Galvanised Steel
 Impeller: Aluminum
 Inlet Cone: Polyamide FRP
Rotation Backward

Motor (kW)	0.37	0.75	1.5	2.2	3.7	5.5	7.5	11	15	18.5	22
Motor Weight (kg)	8.5	11	20	24	40	49	54	100	125	160	180
Fan Weight (kg)	-	-	134	134	134	134	134	134	-	-	-
Total Weight (kg)	-	-	154	158	174	183	188	234	-	-	-

Unit : mm

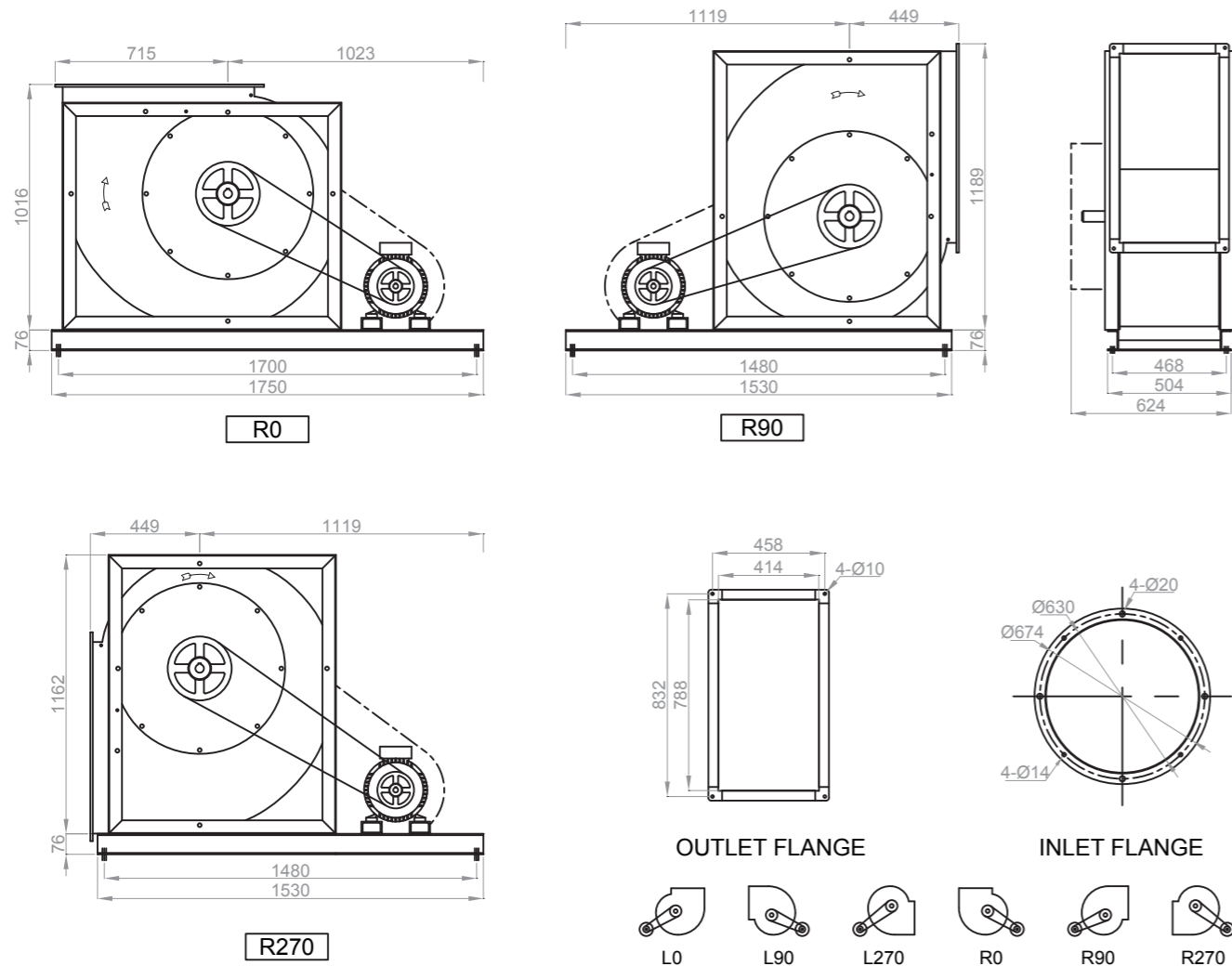

*Refer to page 69 for dimensions and weight of WBS 630 Overhung Type.

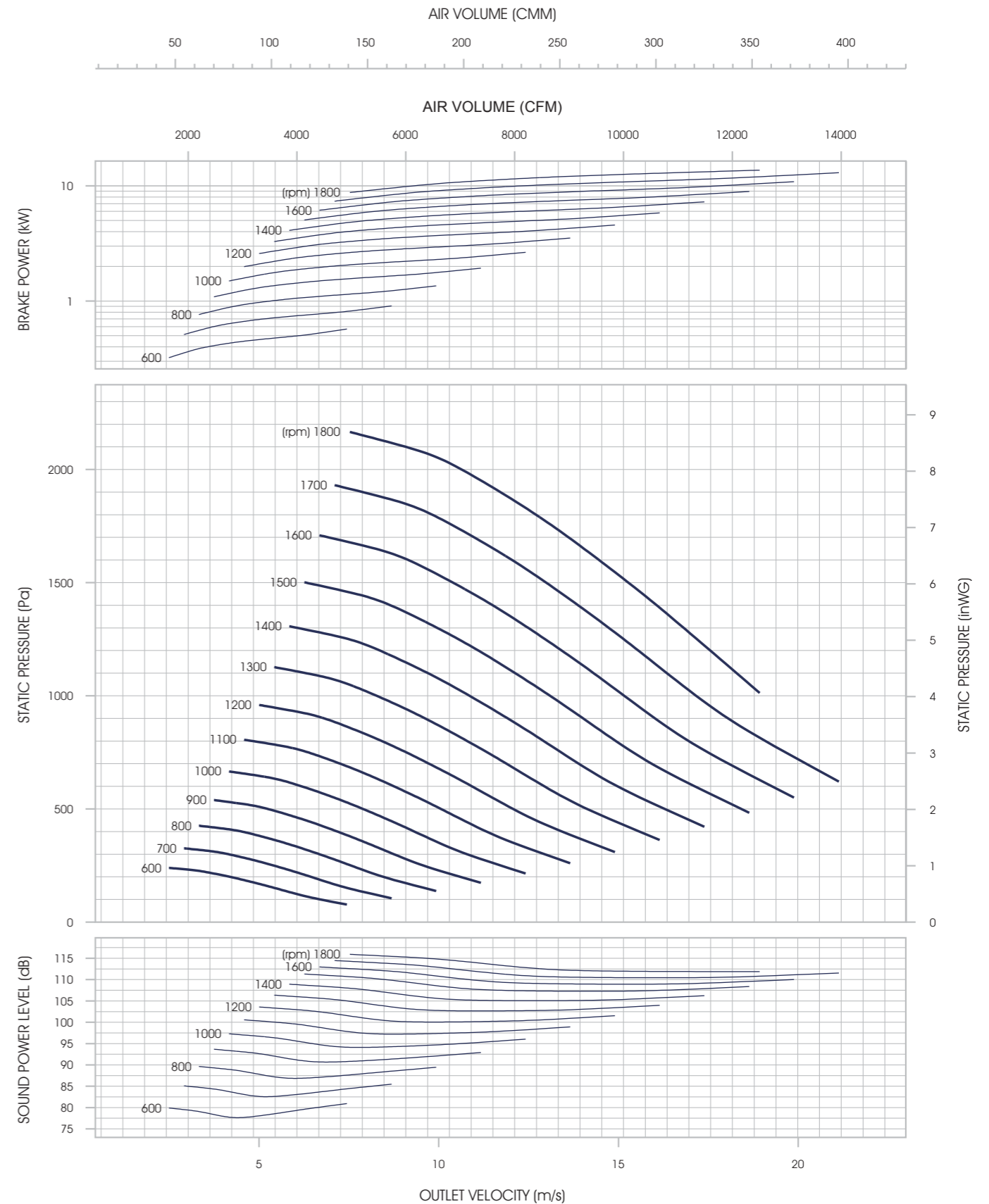

- 1) Power rating (B.kW) does not include transmission loss.
- 2) Performance ratings do not include the effects of appurtenances (accessories).
- 3) Performance certified is for installation type B - Free inlet, Ducted outlet.
- 4) The sound power level ratings shown are in decibels, referred to 10⁻¹² watts, calculated per AMCA International Standard 301.
- 5) Values shown are for inlet LWi sound power levels for Installation Type B: free inlet, ducted outlet.

WBS 710

Backward Curved Single Inlet SWSI



Wheel Diameter 710 mm.
Outlet Area 0.4192 m²
Material Casing: Galvanised Steel
 Impeller: Aluminum
 Inlet Cone: Polyamide FRP
Rotation Backward

Motor (kW)	0.37	0.75	1.5	2.2	3.7	5.5	7.5	11	15	18.5	22
Motor Weight (kg)	8.5	11	20	24	40	49	54	100	125	160	180
Fan Weight (kg)	-	-	232	232	232	232	232	232	232	-	-
Total Weight (kg)	-	-	252	256	272	281	286	332	357	-	-

Unit : mm

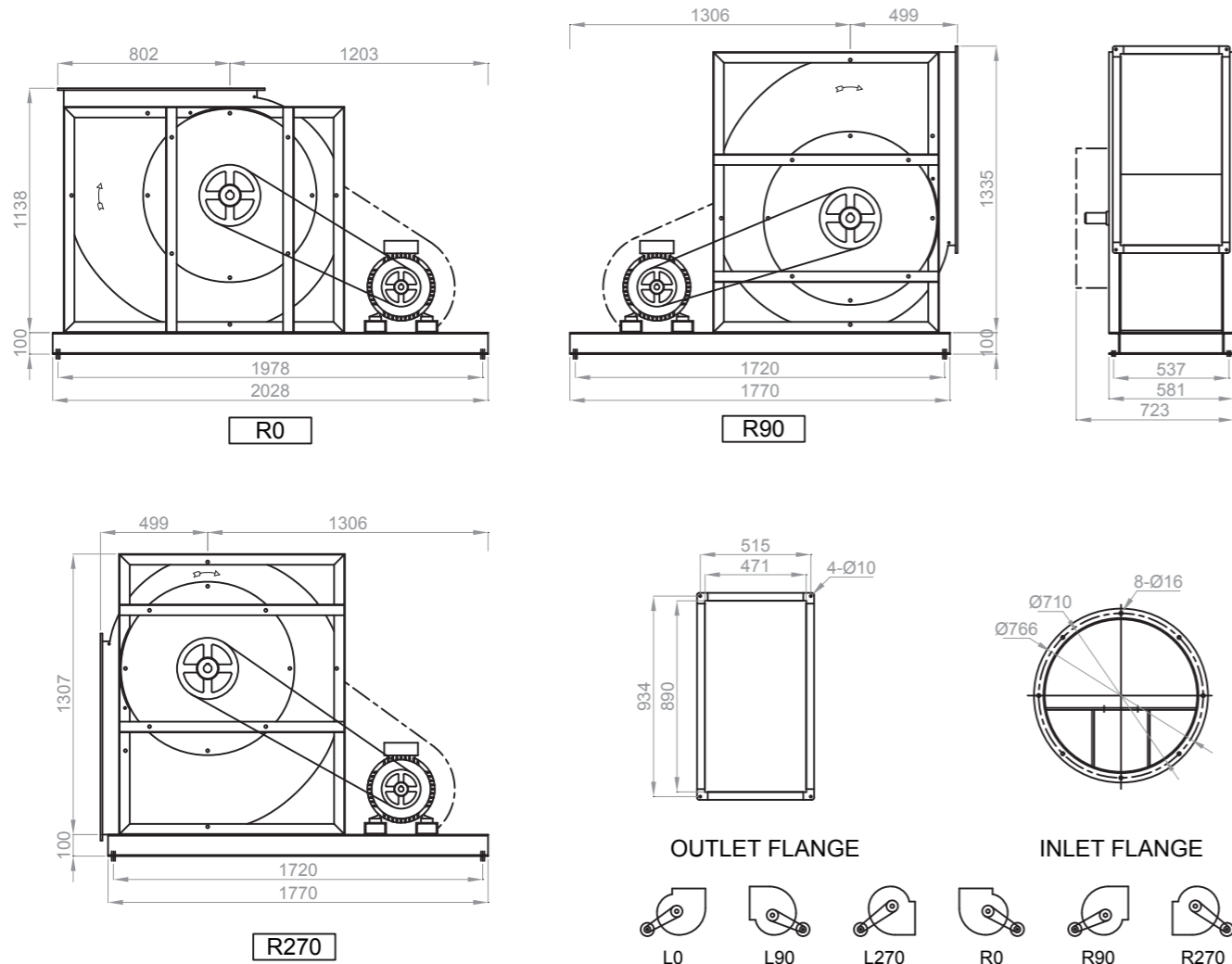

*Refer to page 70 for dimensions and weight of WBS 710 Overhung Type.

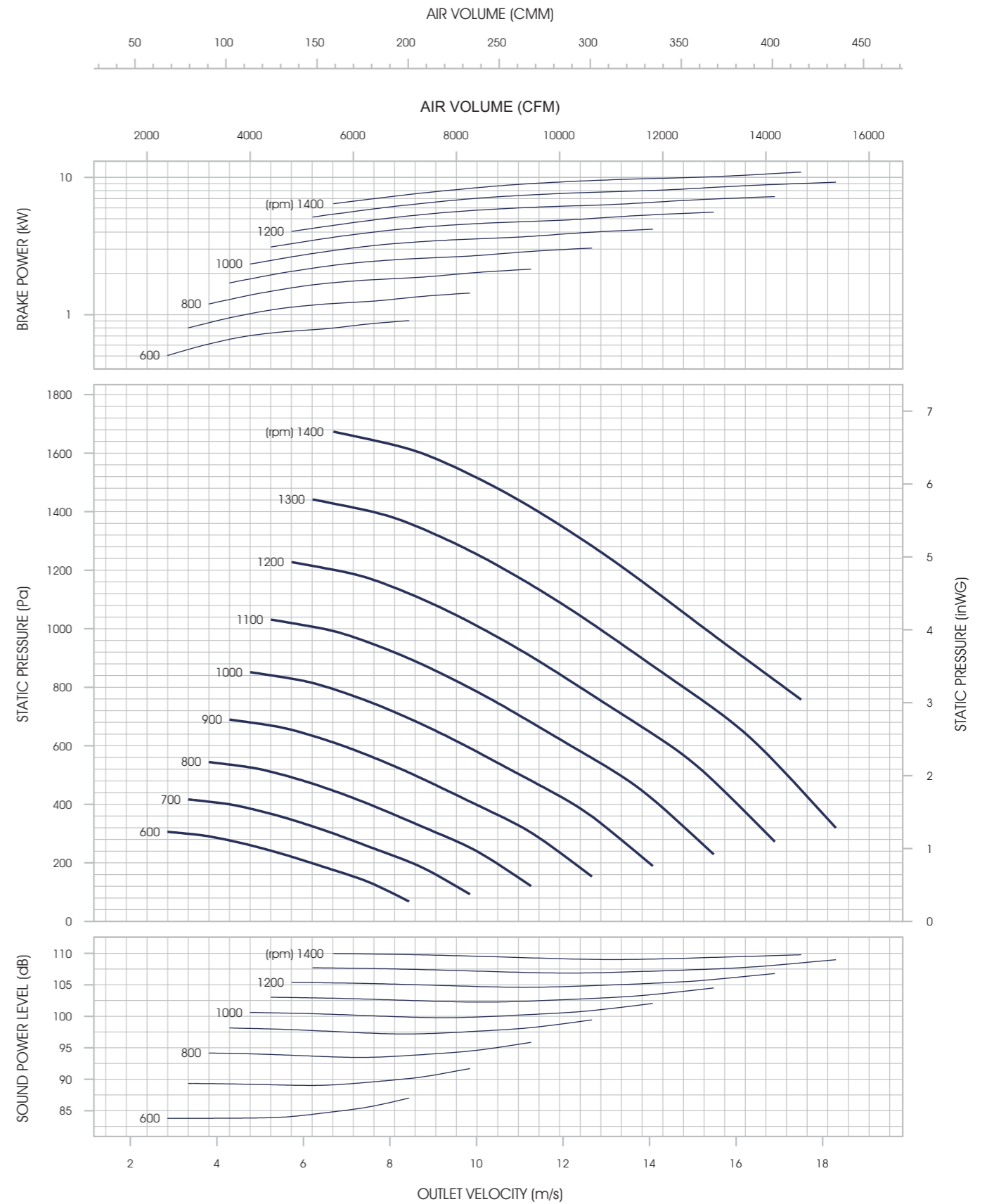

- 1) Power rating (B.KW) does not include transmission loss.
- 2) Performance ratings do not include the effects of appurtenances (accessories).
- 3) Performance certified is for installation type B - Free inlet, Ducted outlet.
- 4) The sound power level ratings shown are in decibels, referred to 10⁻¹² watts, calculated per AMCA International Standard 301.
- 5) Values shown are for inlet LWi sound power levels for Installation Type B: free inlet, ducted outlet.

WBS 800

Backward Curved Single Inlet SWSI



Wheel Diameter 800 mm.
Outlet Area 0.529 m²
Material Casing: Galvanised Steel
 Impeller: Aluminum
 Inlet Cone: Polyamide FRP
Rotation Backward

Motor (kW)	0.37	0.75	1.5	2.2	3.7	5.5	7.5	11	15	18.5	22
Motor Weight (kg)	8.5	11	20	24	40	49	54	100	125	160	180
Fan Weight (kg)	-	-	245	245	245	245	245	245	245	-	-
Total Weight (kg)	-	-	265	269	285	294	299	345	370	-	-

Unit : mm

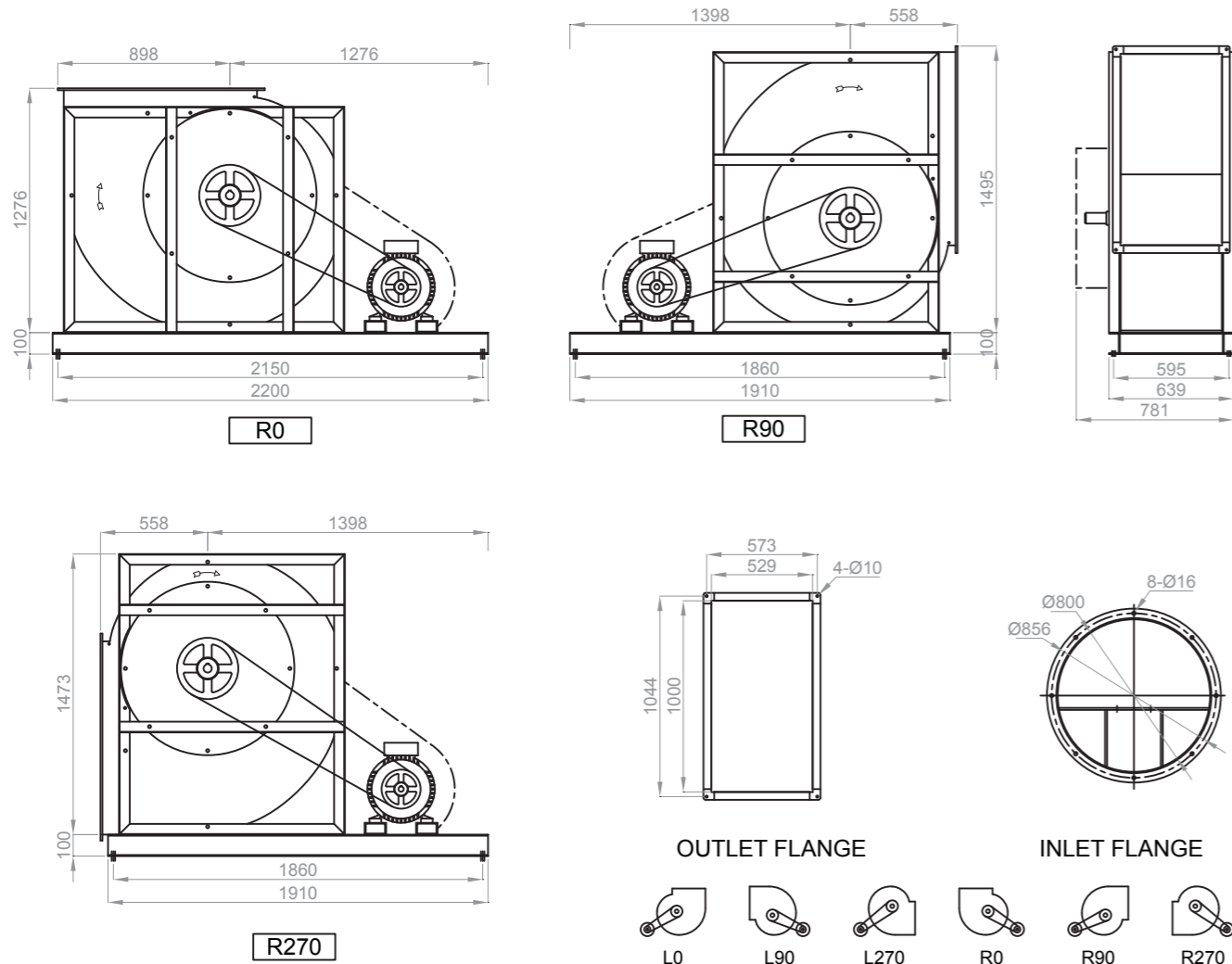

*Refer to page 70 for dimensions and weight of WBS 800 Overhung Type.

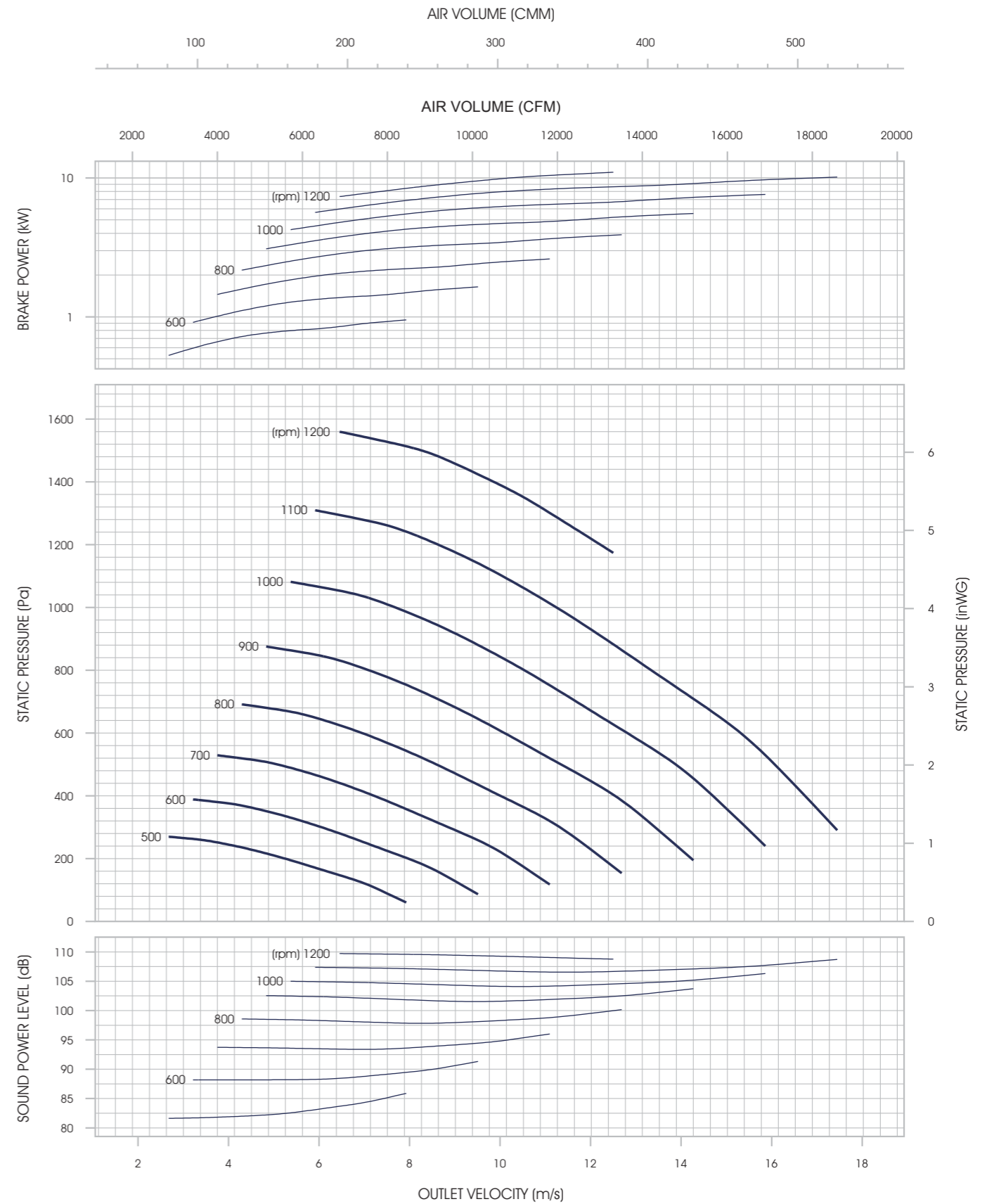

- 1) Power rating (B.KW) does not include transmission loss.
- 2) Performance ratings do not include the effects of appurtenances (accessories).
- 3) Performance certified is for installation type B - Free inlet, Ducted outlet.
- 4) The sound power level ratings shown are in decibels, referred to 10⁻¹² watts, calculated per AMCA International Standard 301.
- 5) Values shown are for inlet LWI sound power levels for Installation Type B: free inlet, ducted outlet.

WBS 900

Backward Curved Single Inlet SWSI



Wheel Diameter 900 mm.
Outlet Area 0.669 m²
Material Casing: Galvanised Steel
 Impeller: Aluminum
 Inlet Cone: Polyamide FRP
Rotation Backward

Motor (kW)	0.37	0.75	1.5	2.2	3.7	5.5	7.5	11	15	18.5	22
Motor Weight (kg)	8.5	11	20	24	40	49	54	100	125	160	180
Fan Weight (kg)	-	-	-	336	336	336	336	336	336	336	-
Total Weight (kg)	-	-	-	360	376	385	390	436	461	496	-

Unit : mm

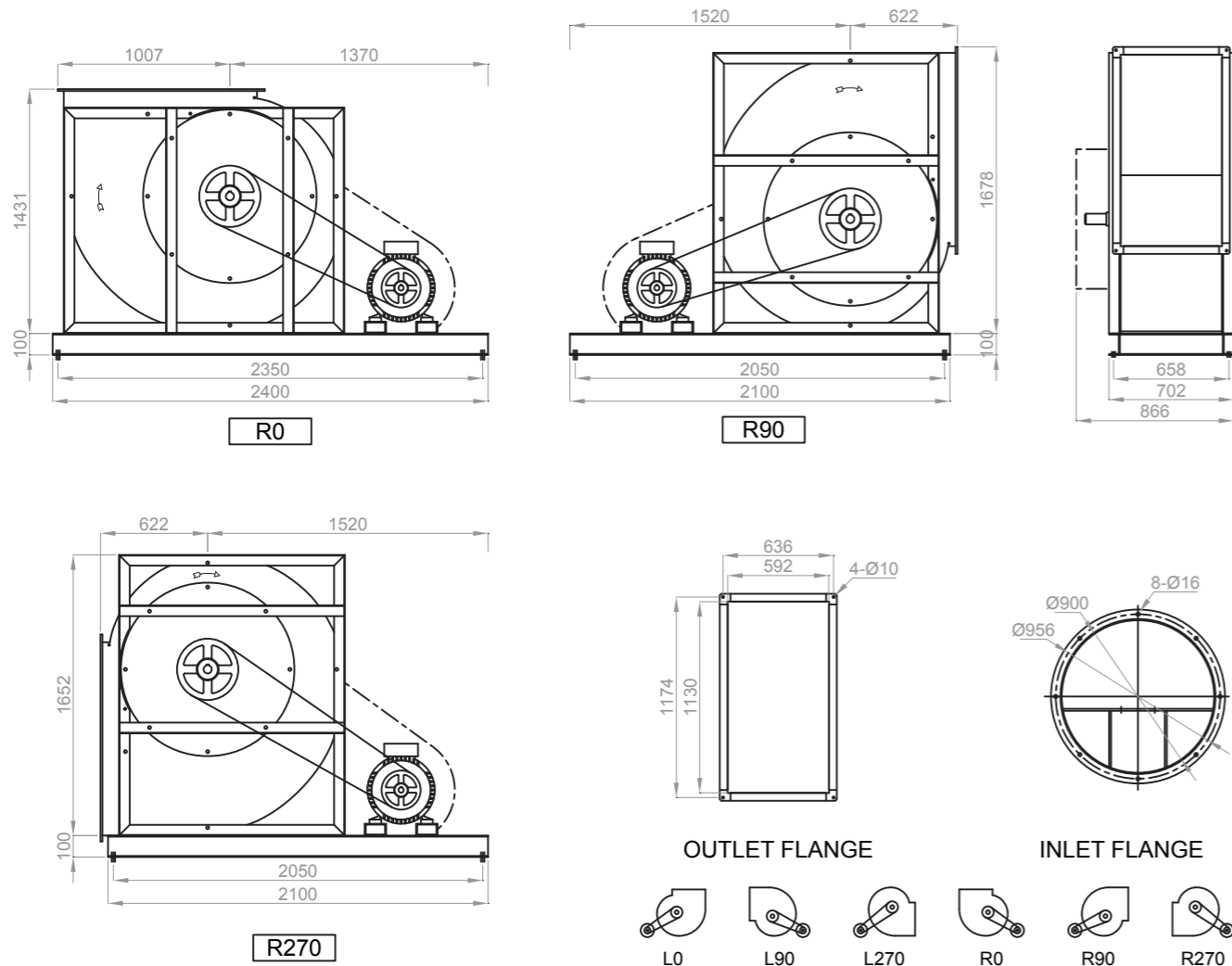

*Refer to page 70 for dimensions and weight of WBS 900 Overhung Type.

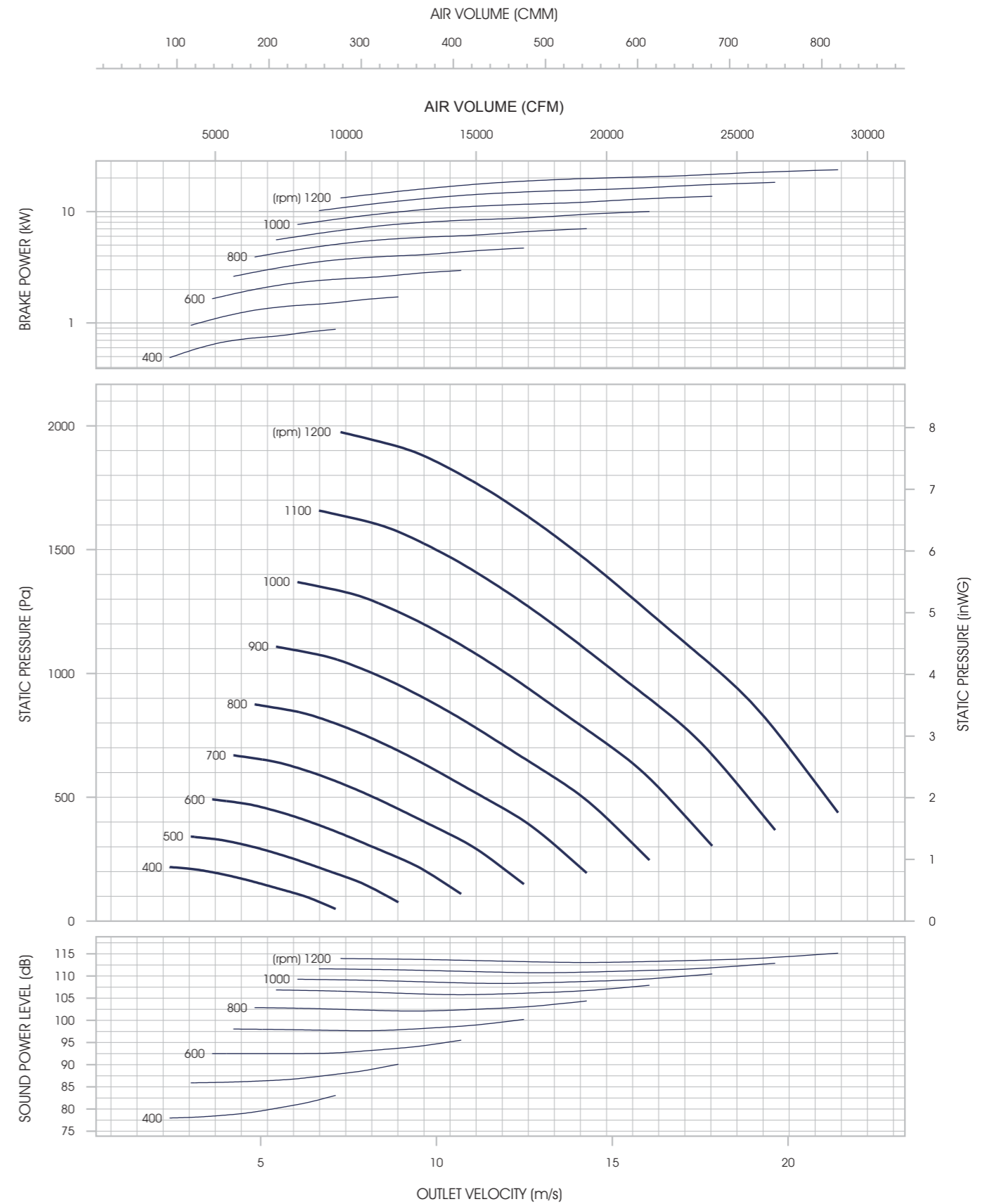

- 1) Power rating (B.kW) does not include transmission loss.
- 2) Performance ratings do not include the effects of appurtenances (accessories).
- 3) Performance certified is for installation type B - Free inlet, Ducted outlet.
- 4) The sound power level ratings shown are in decibels, referred to 10⁻¹² watts, calculated per AMCA International Standard 301.
- 5) Values shown are for inlet LWi sound power levels for Installation Type B: free inlet, ducted outlet.

WBS 1000

Backward Curved Single Inlet SWSI



Wheel Diameter 1000 mm.
Outlet Area 0.8186 m²
Material Casing: Galvanised Steel
 Impeller: Aluminum
 Inlet Cone: Polyamide FRP
Rotation Backward

Motor (kW)	0.37	0.75	1.5	2.2	3.7	5.5	7.5	11	15	18.5	22
Motor Weight (kg)	8.5	11	20	24	40	49	54	100	125	160	180
Fan Weight (kg)	-	-	-	389	389	389	389	389	389	389	389
Total Weight (kg)	-	-	-	413	429	438	443	489	514	549	569

Unit : mm

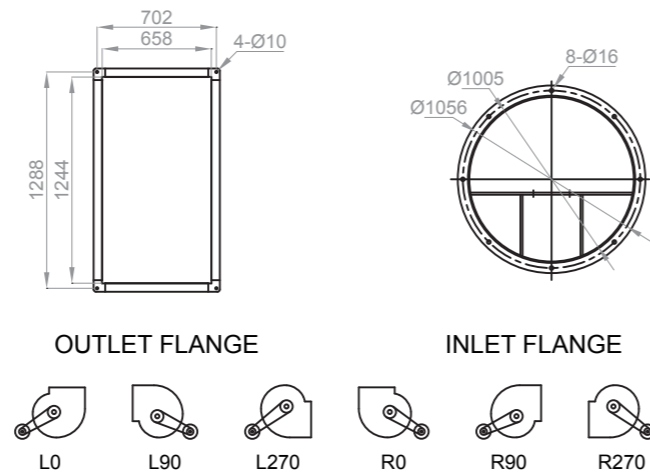
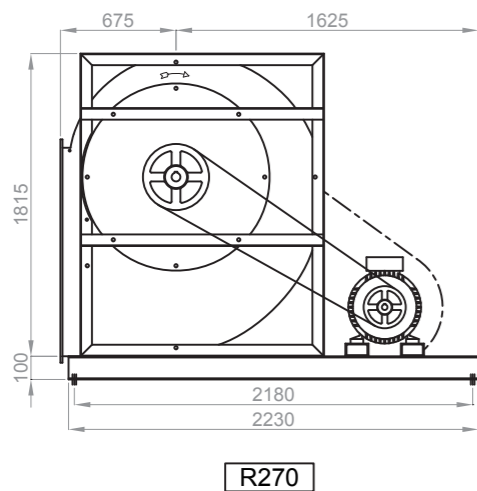
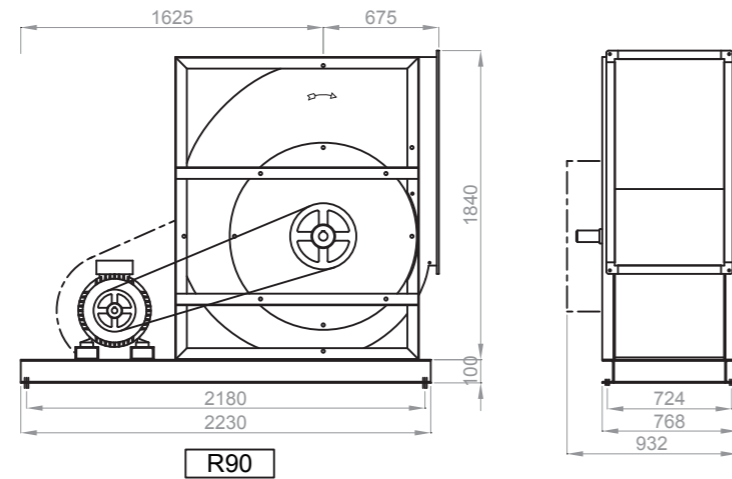
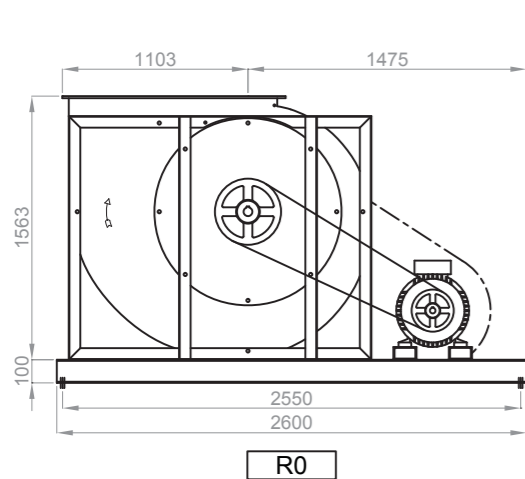

*Refer to page 70 for dimensions and weight of WBS 1000 Overhung Type.

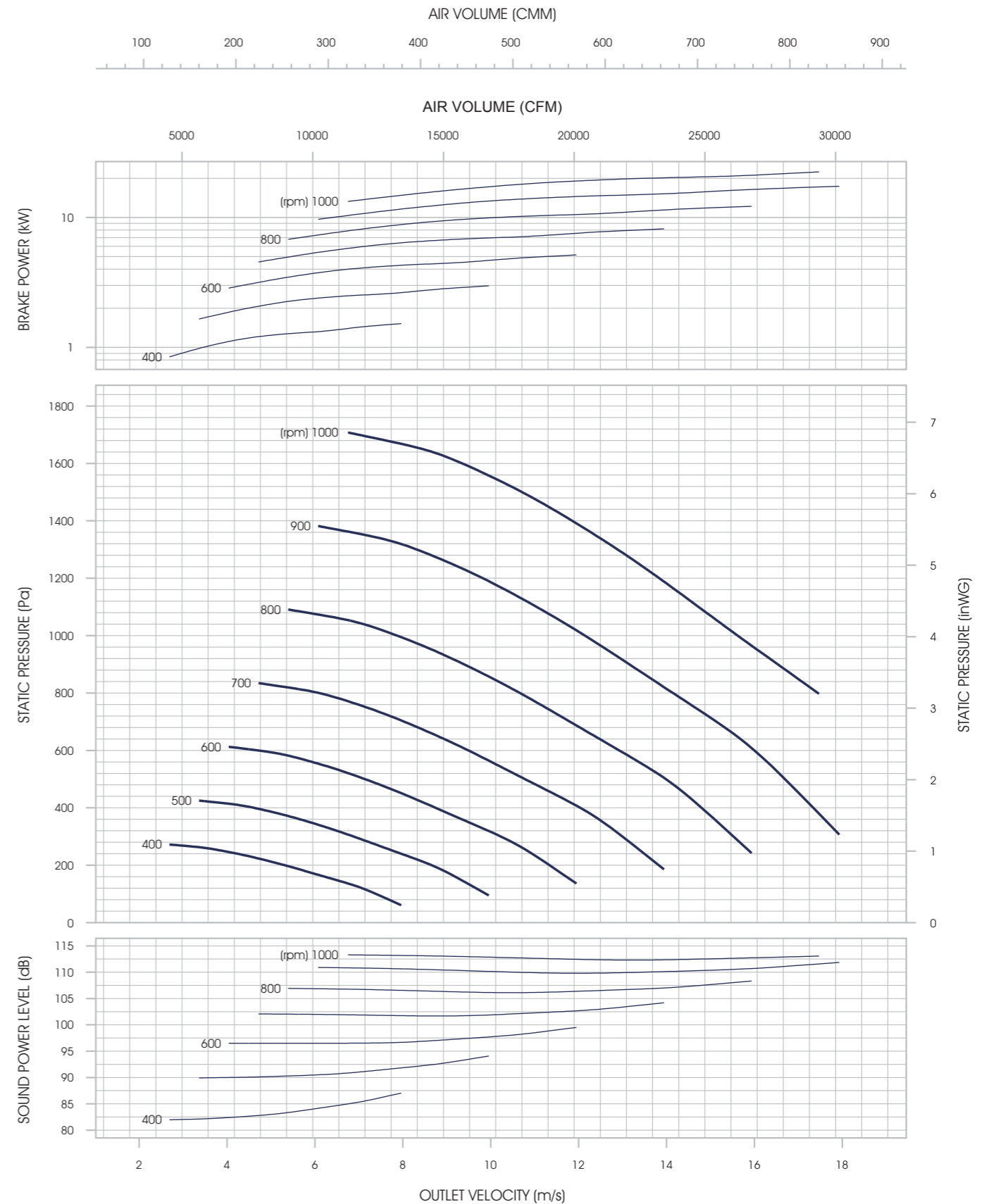

- 1) Power rating (B.kW) does not include transmission loss.
- 2) Performance ratings do not include the effects of appurtenances (accessories).
- 3) Performance certified is for installation type B - Free inlet, Ducted outlet.
- 4) The sound power level ratings shown are in decibels, referred to 10⁻¹² watts, calculated per AMCA International Standard 301.
- 5) Values shown are for inlet LWi sound power levels for Installation Type B: free inlet, ducted outlet.

DIMENSIONS & WEIGHT

Backward Curved Single Inlet SWSI - Overhung Type

Model No.	A1	A2	B1	B2	C1	C2	ØD1	ØD2	n-ØD3	n-ØD4	n-ØD5
WBS 280-O	690	620	197	230	457	500	280	320	3-16	3-10	4-10
WBS 315-O	740	670	218	250	498	541	315	356	3-16	3-10	4-10
WBS 355-O	810	740	246	290	566	619	355	395	4-16	4-10	4-10
WBS 400-O	850	780	272	300	602	655	400	438	4-16	4-10	4-10

Model No.	E1	E2	F1	F2	G	H1	H2	H3	I1	I2	J
WBS 280-O	184	228	350	394	110	397	469	477	347	225	515
WBS 315-O	205	249	394	438	130	430	512	520	377	247	550
WBS 355-O	233	277	444	488	130	490	585	593	420	272	597
WBS 400-O	259	303	500	544	130	559	665	674	468	302	615

Model No.	MOTOR (kW)	0.37	0.75	1.5	2.2	3.7	5.5	7.5	11	15	18.5	22
	WEIGHT (kg)	8.5	11	20	24	40	49	54	100	125	160	180
WBS 280-O	23	31.5	34	43	47	-	-	-	-	-	-	-
WBS 315-O	31	39.5	42	51	55	-	-	-	-	-	-	-
WBS 355-O	35	43.5	46	55	59	75	-	-	-	-	-	-
WBS 400-O	48	56.5	59	68	72	88	-	-	-	-	-	-

Unit : mm

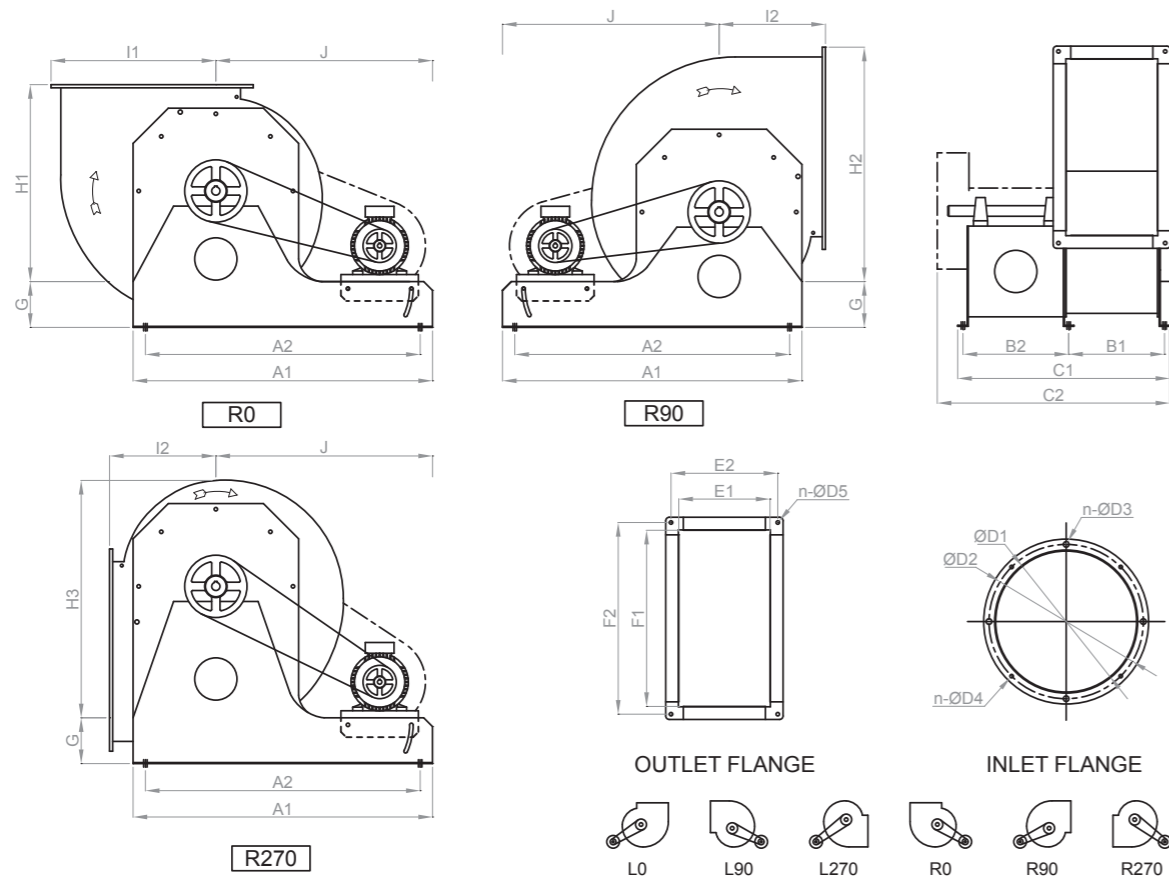

Model No.	A1	A2	B1	B2	C1	C2	ØD1	ØD2	n-ØD3	n-ØD4	n-ØD5
WBS 450-O	980	910	306	350	686	749	450	487	4-16	4-10	4-10
WBS 500-O	1050	980	339	375	744	807	500	541	4-16	4-10	4-10
WBS 560-O	1150	1070	382	440	862	936	560	605	4-20	4-14	4-10
WBS 630-O	1250	1170	428	440	908	982	630	674	4-20	4-14	4-10

Model No.	E1	E2	F1	F2	G	H1	H2	H3	I1	I2	J
WBS 450-O	293	337	560	604	190	575	697	705	522	333	720
WBS 500-O	326	370	626	670	193	648	786	794	575	363	760
WBS 560-O	368	412	700	744	204	733	885	893	640	405	820
WBS 630-O	414	458	788	832	204	839	1012	1020	715	449	885

Model No.	MOTOR (kW)	0.37	0.75	1.5	2.2	3.7	5.5	7.5	11	15	18.5	22
	WEIGHT (kg)	8.5	11	20	24	40	49	54	100	125	160	180
WBS 450-O	61	-	72	81	85	101	110	-	-	-	-	-
WBS 500-O	129	-	140	149	153	169	178	-	-	-	-	-
WBS 560-O	172	-	183	192	196	212	221	226	-	-	-	-
WBS 630-O	196	-	-	216	220	236	245	250	-	-	-	-

Unit : mm

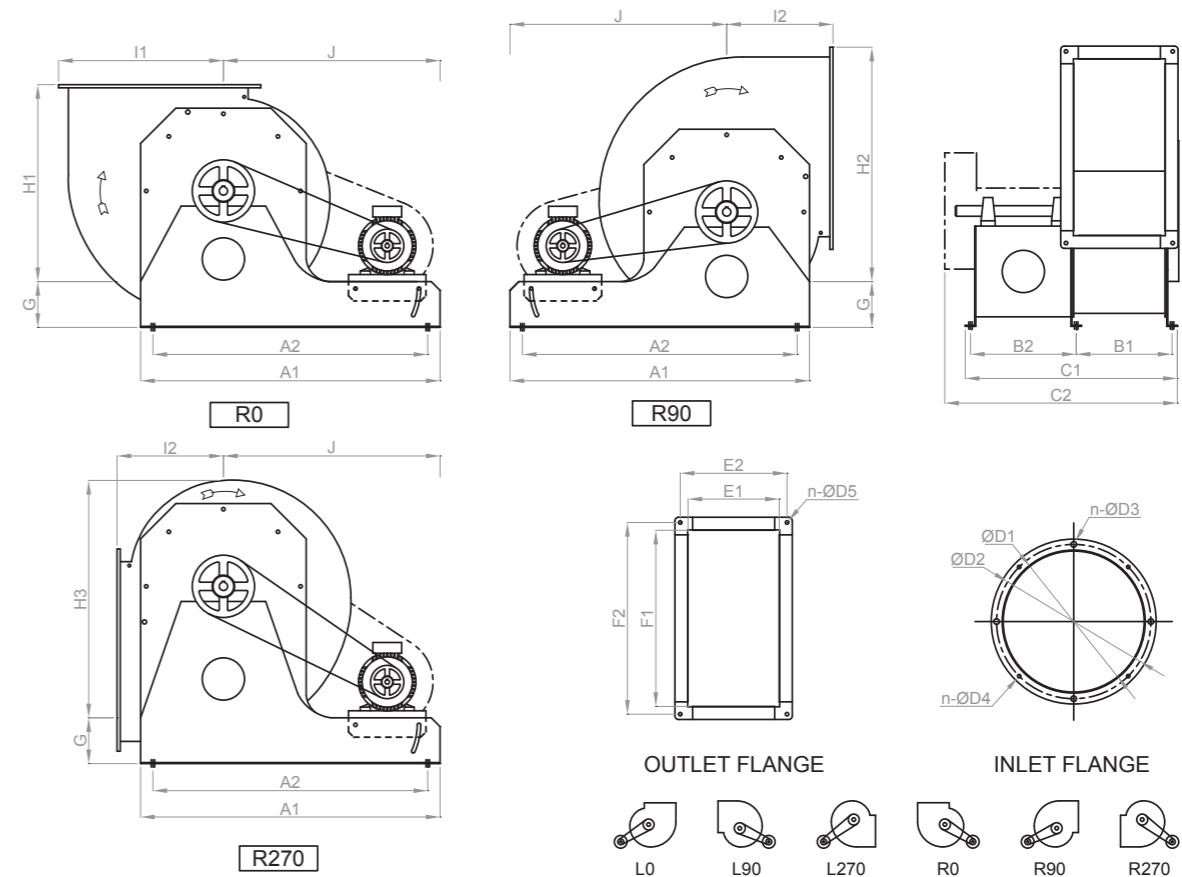

DIMENSIONS & WEIGHT

Backward Curved Single Inlet SWSI - Overhung Type

Model No.	A1	A2	A3	A4	B1	B2	C1	C2	ØD1	ØD2	n-ØD3	n-ØD4
WBS 710-O	1940	1890	1700	1650	537	405	986	1116	710	766	8-16	4-10
WBS 800-O	2100	2050	1800	1750	595	445	1084	1211	800	856	8-16	4-10
WBS 900-O	2300	2250	1960	1910	658	530	1232	1371	900	956	8-16	4-10
WBS 1000-O	2500	2450	2130	2080	724	620	1388	1524	1005	1056	8-16	4-10

Model No.	E1	E2	F1	F2	G	H1	H2	H3	I1	I2	J1	J2
WBS 710-O	471	515	890	934	100	1138	1335	1307	802	499	1116	1237
WBS 800-O	529	573	1000	1044	100	1276	1495	1473	898	558	1174	1295
WBS 900-O	592	636	1130	1174	100	1431	1678	1652	1007	622	1269	1400
WBS 1000-O	658	702	1244	1288	100	1563	1840	1815	1103	675	1372	1522

Model No.	MOTOR (kW)	0.37	0.75	1.5	2.2	3.7	5.5	7.5	11	15	18.5	22
	WEIGHT (kg)	8.5	11	20	24	40	49	54	100	125	160	180
WBS 710-O	327	-	-	347	351	367	376	381	427	452	-	-
WBS 800-O	396	-	-	416	420	436	445	450	496	521	-	-
WBS 900-O	520	-	-	-	544	560	569	574	620	645	680	-
WBS 1000-O	610	-	-	-	634	650	659	664	710	735	770	790

Unit : mm

