

Volume Control Damper

5" Deep · 6" Airfoil Blade · Aluminum Construction

AAA/AAB

STANDARD MATERIALS AND CONSTRUCTION

- FRAME:** 5" x .081" extruded aluminum, hat shaped
- BLADES:** 6" x .081" extruded aluminum, single unit airfoil design, with the pin-lock an integral section within the blade core
- AXLES:** ½" dia. extruded aluminum, pin-lock design interlocking into blade section
- BEARINGS:** Celcon
- LINKAGE:** Aluminum crank-arm permanently locked to have the blade shaft by 2 stainless steel fasteners; Crank-arm contains a ½" dia. cadmium plated and chromate treated machined steel trunnion riding in a cecon bearing; A plated steel ¼-20 set screw with locking patch, ties the pivot to the 5/16" dia. aluminum linkage rod; The linkage of each damper is individually adjusted
- SEALS:** Extruded silicone rubber seal
- FINISH:** Mill
- ACTUATOR:** 6" extended shaft; dampers more than one panel wide or high and operated with one actuator must be jackshafed; Factory supplied actuators are shipped loose to be mounted external as standard

OPTIONS

- Hand Quadrants
- 120V, 24V, or Pneumatic Actuators
- Jackshafing
- Auxillary Switch
- Explosion Proof Housing

NOTES

1. "A" width and "B" height are opening dimensions. Dampers are provided approximately ¼" undersize.
2. Dampers with multiple panels in both width and height may require structural support. It is recommended that large openings be designed with structural members so that dampers will span either width or height with a single panel. Cesco Products does not supply structural support with standard dampers.
3. Not recommended for blades installed vertically.
4. Approximate damper weight is 5.5 lbs./sq.ft.

DAMPER SIZE

Panels	Minimum Panel	Maximum Panel
AAA	12"W x 12"H	60"W x 72"H
AAB	12"W x 14⅝"H	60"W x 72"H

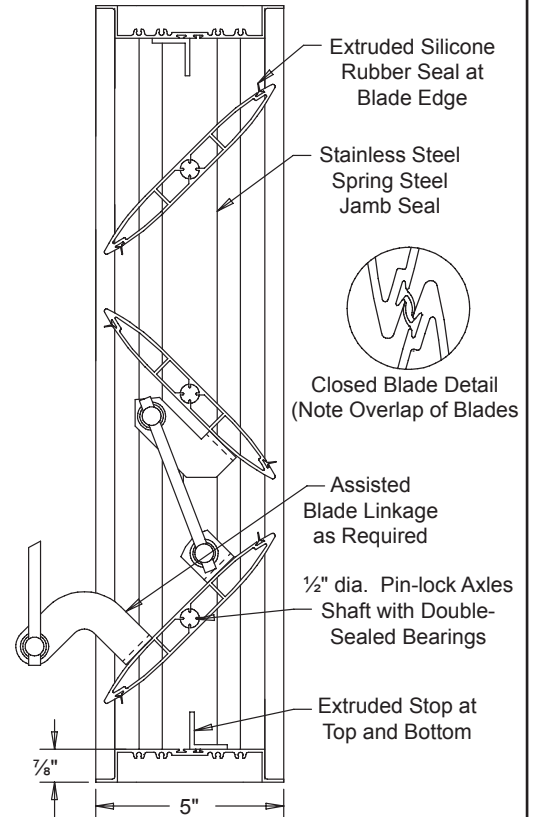
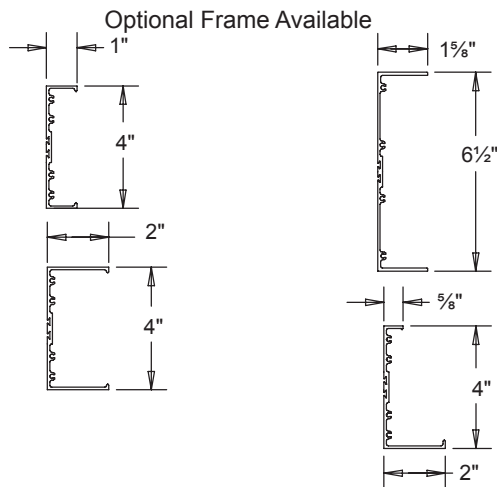

AAB (Opposed Blade)

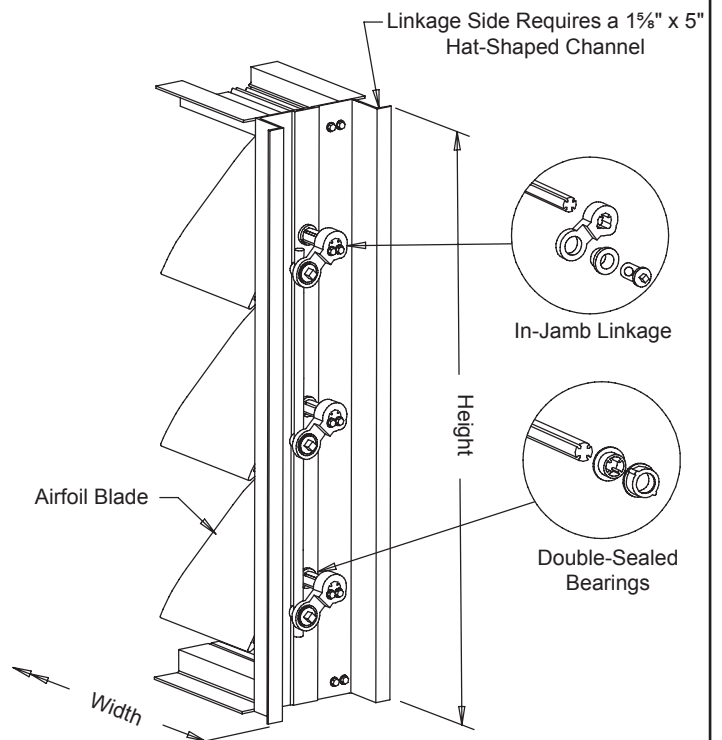

AAA (Parallel Blade)



P.O. Box 606 · Florence, KY 41042
 Phone: 859-538-3450 · Fax: 859-647-7810
 www.cescoproducts.com

SD-AAA-AAB-09.08

Volume Control Damper

5" Deep · 6" Airfoil Blade · Aluminum Construction

AAA/AAB

Pressure Drop:

Pressure Drop Ratings are based on AMCA Standard 500 using test set-up Fig. 5.3 for damper installed with duct upstream and downstream. Static pressures are corrected to .075 lb./cu.ft. air density.

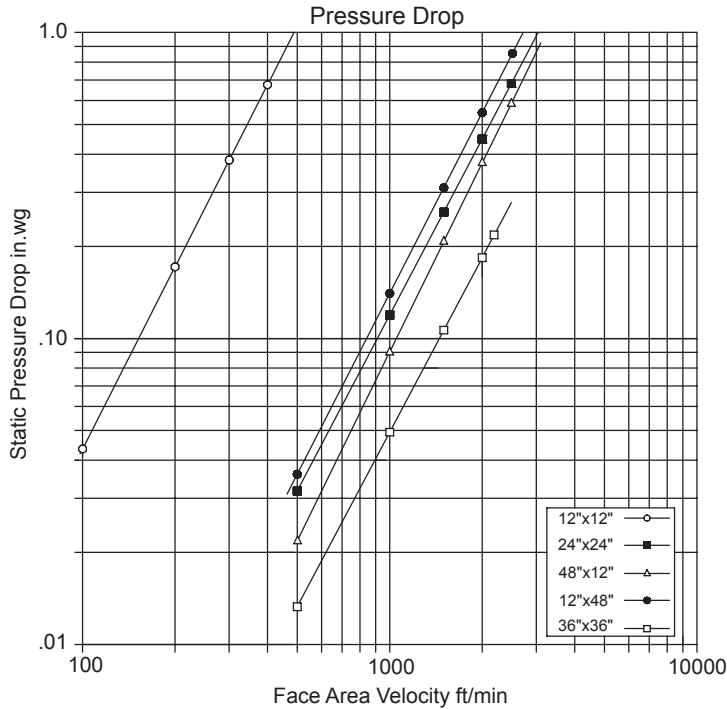

12"W x 12"H		24"W x 24"H	
Face Area Velocity ft/min	Pressure Drop in.wg	Face Area Velocity ft/min	Pressure Drop in.wg
100	0.04	500	0.03
200	0.16	1000	0.12
300	0.38	1500	0.25
400	0.69	2000	0.45
500	1.00	2500	0.68

12"W x 48"H		48"W x 12"H	
Face Area Velocity ft/min	Pressure Drop in.wg	Face Area Velocity ft/min	Pressure Drop in.wg
500	0.04	500	.02
1000	0.14	1000	.09
1500	0.31	1500	.20
2000	0.56	2000	.38
2500	0.85	2500	.58

36"W x 36"H	
Face Area Velocity ft/min	Pressure Drop in.wg
500	0.01
1000	0.05
1500	0.10
2000	0.18
2500	0.21

Leakage

Air Leakage requirements meet international energy conservation code (IECC) by leaking less than 3 cfm/sq.ft. at 1 in.wg and is AMCA licensed as a Class 1A Damper

Damper Size	1 in.wg Class	4 in.wg Class
12"W x 12"H	1A	1
24"W x 24"H	1A	1
36"W x 36"H	1A	1
12"W x 48"H	1A	1
48"W x 12"H	1A	1
60"W x 36"H	1A	1

Leakage Ratings are based on AMCA Standard 500 using test set-up Fig. 5.5 at an operation temperature range between 50°F & 104°F. Data is based on a seating torque of 40 lb/in for dampers less than 4 sq.ft in size. Dampers above 4 sq.ft., 5 lb/in/sq.ft is applied to hold the damper in the closed position.

Damper Air Leakage Classification

		Leakage cfm/ft²	
		Required Rating	
Class	Pressure	1 in.wg	4 in.wg
		1A	3
1		4	8
2		10	20
3		40	80



Cesco Products certifies that the model AAA/AAB damper shown herein is licensed to bear the AMCA Seal. The ratings shown are based on tests and procedures performed in accordance with AMCA Publication 511 and comply with the requirements of the AMCA Certified Ratings program. The AMCA Certified Rating Seal applies to Air Performance/Air Leakage only.



Volume Control Damper

5" Deep · 6" Airfoil Blade · Aluminum Construction

AAA/AAB

Linear Air Flow Characteristics

Cesco Products has tested a variety of airfoil blade widths 4", 5", and 6" in various arrangements from all parallel, all opposed, and combinations of parallel and opposed blades in a common frame for a single damper installed in a duct.

Test units were installed in ductwork with duct upstream and downstream per AMCA test set-up Fig. 5.3. Using most common approach velocities and fan static.

The results of the tests show that fan static pressure does have an effect on the linear air flow characteristics of a damper. Graphs below will identify the simulated system conditions used for the single damper in duct system application

Curves shown in the graphs below show that model AAB all opposed "as standardly built" is a very effective control damper for use in a variety of velocities and pressures.

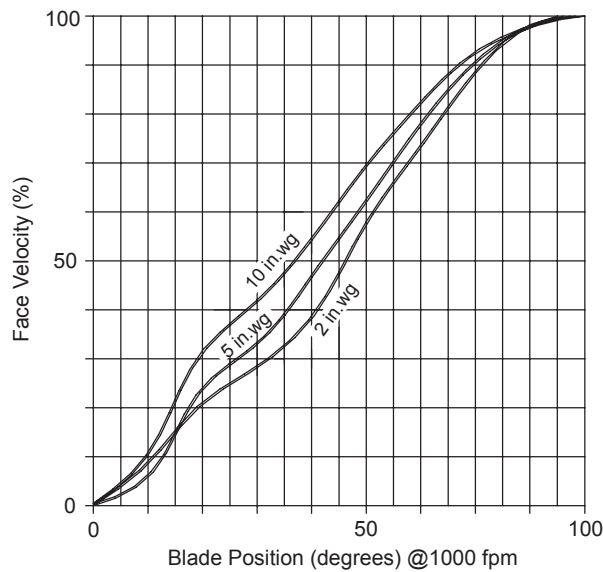
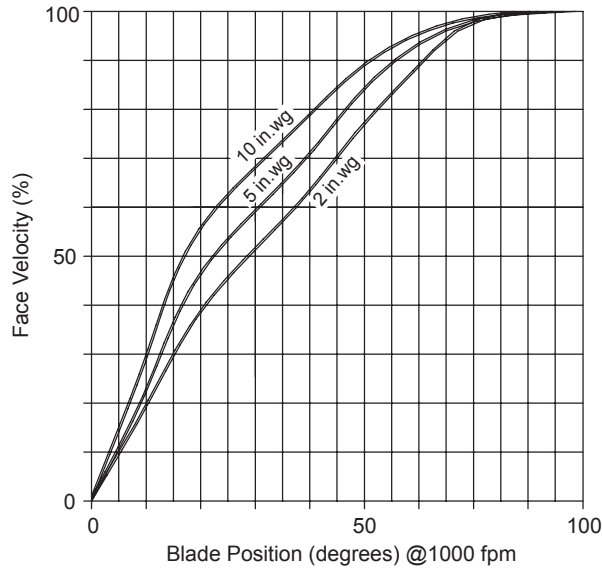

P.O. Box 606 · Florence, KY 41042
Phone: 859-538-3450 · Fax: 859-647-7810

www.cescoproducts.com

SD-AAA-AAB-09.08

Volume Control Damper
5" Deep · 6" Airfoil Blade · Aluminum Construction

AAA/AAB

This page intentionally left blank.

