

## ELC6375DXD DRAINABLE COMBINATION LOUVER

MIAMI-DADE APPROVED

MIAMI-DADE COUNTY, FLORIDA NOTICE OF ACCEPTANCE NUMBER: 14-0211.15 (2/11/19)  
FLORIDA PRODUCT APPROVAL #FL12232.1

### STANDARD CONSTRUCTION

#### FRAME

6" (152) deep, 6063T6 extruded aluminum with .125" (3.2) nominal wall thickness. Downspouts and caulking surfaces provided.

#### BLADES

Front stationary drainable blades – 6063T6 extruded aluminum with .081" (2.1) nominal wall thickness, positioned at 37<sup>1</sup>/<sub>2</sub>° angle and spaced approximately 6<sup>1</sup>/<sub>8</sub>" (156) on center. Rear adjustable airfoil blades – 6063T5 extruded aluminum, .140" (3.6) nominal wall thickness.

#### SCREEN

5/8" x .040" (16 x 1) expanded, flattened aluminum bird screen in removable frame. Screen adds approximately 1/2" (13) to louver depth.

#### SEALS

Extruded vinyl blade edge seals on rear adjustable blades and flexible, compressible aluminum jamb seals.

#### LINKAGE

Concealed in frame.

#### BEARINGS

Stainless steel sleeve pressed into frame.

#### AXLES

1/2" (13) plated steel hex.

#### ACTUATOR

Locking louver quadrant.

#### FINISH

Mill.

#### MINIMUM SIZE

12"w x 12"h (305 x 305).

#### APPROXIMATE SHIPPING WEIGHT

8 lbs. per sq. ft. (39.1 kg per m<sup>2</sup>).

#### MAXIMUM SIZE

55"w x 120"h (1397 x 3048) factory assembly, unlimited width x 120"h field assembly. Louvers larger than the maximum factory assembly size will require field assembly of smaller sections.

#### INSTALLATION

The ELC6375DXD must be installed per the appropriate installation detail. Reference the appropriate separate installation instruction sheet.

#### MULLION SUPPORTS

Factory installed mullion supports are provided at rear of hidden mullions. Mullion depth = 1" (25) for louvers 75<sup>3</sup>/<sub>4</sub>" (1924) tall and under. Depth = 5<sup>1</sup>/<sub>8</sub>" (130) for louvers over 75<sup>3</sup>/<sub>4</sub>" (1924) tall.

Dimensions in inches, parenthesis ( ) indicate millimeters.

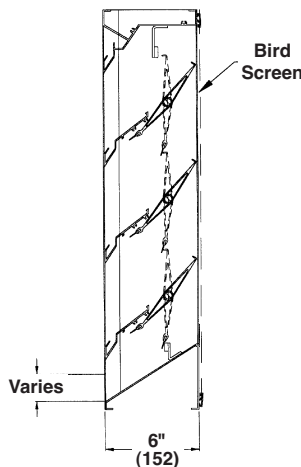
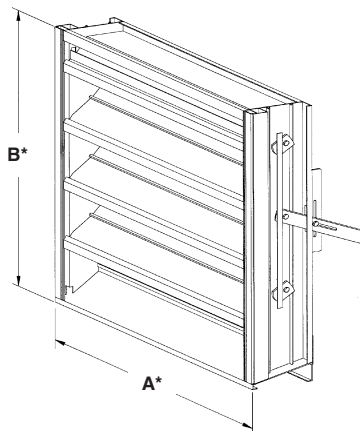

### FEATURES

- Approved for use in open structures with provisions to manage weather infiltration (wet rooms).
- Maximum windload ±110 PSF (5.27 kPa).
- 44% free area in 48" x 48" (1.2 x 1.2) size.
- Published performance ratings based on testing in accordance with AMCA Publication 511.
- Adjustable rear blades provide shut off when desired.
- Concealed blade linkage is protected from weather exposure and reduces required installation depth.
- Blade and jamb seals provide tight closure.
- High performance drainable frame and blade system collects and removes water providing excellent water penetration performance.

### VARIATIONS

Variations to the basic design of the louver are available at additional cost. They include:

- Extended sill.
- Front or rear security bars.
- Filter racks.
- A variety of bird and insect screens.
- A selection of manual, electric, and pneumatic actuators.
- Selection of finishes: prime coat, 50% PVDF (modified fluoropolymer), epoxy, Pearledize, 70% PVDF, clear and color anodize. (Some variation in anodize color consistency is possible).

Consult Ruskin for other special requirements.

ELC6375DXD meets the requirements for the following:

- Miami Dade NOA Certification 12.0913.13
- Florida Product Approved FL-12232.1
- AMCA 500-L Tested

Please reference our website  
[www.ruskin.com](http://www.ruskin.com) for up to date  
LEED information

TAG	QTY.	SIZE		FRAME	VARIATIONS
		A*-WIDE	B*-HIGH		
PROJECT ARCH./ENGR. REPRESENTATIVE				LOCATION CONTRACTOR DATE	

# QUICK SPEC

Furnish and install at locations shown on the plans or as described in schedules combination drainable stationary louver and low leak damper meeting the performance criteria established by the Florida Building Code and Miami-Dade County. Combination louvers shall be certified to FBC standards TAS 201 (Large Missile Impact), TAS 202 (Uniform Static Air Pressure) and TAS 203 (Cyclic Wind Loading). Combination louvers shall be manufactured in an ISO 9001 certified factory.

Combination louvers shall be furnished with bird and/or insect screens, electric, pneumatic, or manual actuators, supports and finishes as specified and as required for a complete installation. Combination louvers shall incorporate drainable stationary blade and separate adjustable airfoil damper blade in a single frame. All blades and frames shall be constructed of 6063-T5 aluminum alloy.

Louvers shall be Ruskin Model ELC6375DXD extruded 6063T6 aluminum alloy construction as follows:

**MATERIAL**

- Frame: .125" (3.2) wall thickness, caulking surfaces provided.
- Blades: Stationary blades shall be .081" (2.1) and adjustable airfoil damper blades shall be .140" (3.6) nominal wall thickness.
- Extended Sill: .081" (2.1) wall thickness with upturned side panels to prevent water leakage.
- Screen: 5/8" x .040" (16 x 1) expanded, flattened aluminum bird screen in removable frame.
- Finish: Select finish specification from Ruskin Finishes Brochure.

**STRUCTURAL DESIGN**

Integral structural supports shall be designed and furnished by the louver manufacturer to carry a wind load of not less than 110 psf (5.27 kPa).

**TAS 203-94 CYCLIC WIND PRESSURE TEST**

CYCLES	LOAD IN PSF (kPa)	LOAD DURATION CYCLE	LOUVER RECOVERY
600	+55.0 (+2.6)	1 to 3 seconds	100%
600	-55.0 (-2.6)	1 to 3 seconds	100%
70	+66.0 (+3.2)	1 to 3 seconds	100%
70	-66.0 (-3.2)	1 to 3 seconds	100%
1	+143.0 (+6.8)	1 to 3 seconds	100%
1	-143.0 (-6.8)	1 to 3 seconds	100%

**WATER PENETRATION**

Test size 48" wide x 48" high (1219 x 1219)

Beginning point of water penetration at .01 oz./sq. ft. is above 1250 fpm (381 m/min).

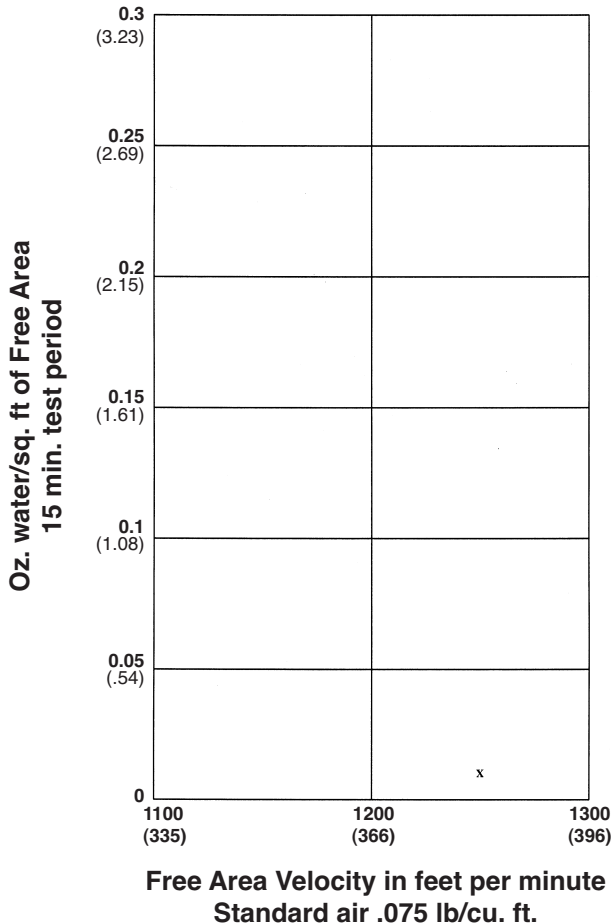

Ruskin Manufacturing Company certifies that the ELC6375DXD louvers shown herein are licensed to bear the AMCA Seal. The ratings shown are based on tests and procedures performed in accordance with AMCA Publication 511 and comply with the requirements of the AMCA Certified Ratings Program. The AMCA Certified Ratings Seal applies to air performance rating and water penetration ratings only.

## FREE AREA GUIDE

Free Area Guide shows free area in ft<sup>2</sup> and m<sup>2</sup> for various sizes of ELC6375DXD.  
Width – Inches (Meters)

	12	18	24	30	36	42	48	55
	0.30	0.46	0.61	0.76	0.91	1.07	1.22	1.40
<b>12</b>	<b>0.25</b>	<b>0.40</b>	<b>0.54</b>	<b>0.62</b>	<b>0.77</b>	<b>0.92</b>	<b>1.07</b>	<b>1.24</b>
0.30	0.02	0.04	0.05	0.06	0.07	0.09	0.10	0.12
<b>18</b>	<b>0.48</b>	<b>0.77</b>	<b>1.06</b>	<b>1.20</b>	<b>1.49</b>	<b>1.78</b>	<b>2.07</b>	<b>2.41</b>
0.46	0.04	0.07	0.10	0.11	0.14	0.17	0.19	0.22
<b>24</b>	<b>0.69</b>	<b>1.11</b>	<b>1.52</b>	<b>1.73</b>	<b>2.14</b>	<b>2.56</b>	<b>2.97</b>	<b>3.46</b>
0.61	0.06	0.10	0.14	0.16	0.20	0.24	0.28	0.32
<b>30</b>	<b>0.93</b>	<b>1.48</b>	<b>2.04</b>	<b>2.31</b>	<b>2.87</b>	<b>3.42</b>	<b>3.98</b>	<b>4.63</b>
0.76	0.09	0.14	0.19	0.22	0.27	0.32	0.37	0.43
<b>36</b>	<b>1.16</b>	<b>1.85</b>	<b>2.55</b>	<b>2.90</b>	<b>3.59</b>	<b>4.29</b>	<b>4.98</b>	<b>5.79</b>
0.91	0.11	0.17	0.24	0.27	0.33	0.40	0.46	0.54
<b>42</b>	<b>1.39</b>	<b>2.23</b>	<b>3.06</b>	<b>3.48</b>	<b>4.32</b>	<b>5.15</b>	<b>5.99</b>	<b>6.96</b>
1.07	0.13	0.21	0.29	0.32	0.40	0.48	0.56	0.65
<b>48</b>	<b>1.63</b>	<b>2.60</b>	<b>3.58</b>	<b>4.06</b>	<b>5.04</b>	<b>6.01</b>	<b>6.99</b>	<b>8.13</b>
1.22	0.15	0.24	0.33	0.38	0.47	0.56	0.65	0.76
<b>54</b>	<b>1.86</b>	<b>2.97</b>	<b>4.09</b>	<b>4.65</b>	<b>5.76</b>	<b>6.88</b>	<b>7.99</b>	<b>9.30</b>
1.37	0.17	0.28	0.38	0.43	0.54	0.64	0.74	0.86
<b>60</b>	<b>2.09</b>	<b>3.35</b>	<b>4.60</b>	<b>5.23</b>	<b>6.49</b>	<b>7.74</b>	<b>9.00</b>	<b>10.46</b>
1.52	0.19	0.31	0.43	0.49	0.60	0.72	0.84	0.97
<b>66</b>	<b>2.33</b>	<b>3.72</b>	<b>5.12</b>	<b>5.81</b>	<b>7.21</b>	<b>8.61</b>	<b>10.00</b>	<b>11.63</b>
1.68	0.22	0.35	0.48	0.54	0.67	0.80	0.93	1.08
<b>72</b>	<b>2.56</b>	<b>4.09</b>	<b>5.63</b>	<b>6.40</b>	<b>7.93</b>	<b>9.47</b>	<b>11.01</b>	<b>12.80</b>
1.83	0.24	0.38	0.52	0.60	0.74	0.88	1.02	1.19
<b>78</b>	<b>2.79</b>	<b>4.47</b>	<b>6.14</b>	<b>6.98</b>	<b>8.66</b>	<b>10.33</b>	<b>12.01</b>	<b>13.96</b>
1.98	0.26	0.42	0.57	0.65	0.81	0.96	1.12	1.30
<b>84</b>	<b>3.03</b>	<b>4.84</b>	<b>6.66</b>	<b>7.57</b>	<b>9.38</b>	<b>11.20</b>	<b>13.01</b>	<b>15.13</b>
2.13	0.28	0.45	0.62	0.70	0.87	1.04	1.21	1.41
<b>90</b>	<b>3.26</b>	<b>5.22</b>	<b>7.17</b>	<b>8.15</b>	<b>10.11</b>	<b>12.06</b>	<b>14.02</b>	<b>16.30</b>
2.29	0.30	0.49	0.67	0.76	0.94	1.12	1.30	1.52
<b>96</b>	<b>3.49</b>	<b>5.59</b>	<b>7.68</b>	<b>8.73</b>	<b>10.83</b>	<b>12.92</b>	<b>15.02</b>	<b>17.47</b>
2.44	0.32	0.52	0.71	0.81	1.01	1.20	1.40	1.62
<b>102</b>	<b>3.73</b>	<b>5.96</b>	<b>8.20</b>	<b>9.32</b>	<b>11.55</b>	<b>13.79</b>	<b>16.02</b>	<b>18.63</b>
2.59	0.35	0.55	0.76	0.87	1.07	1.28	1.49	1.73
<b>108</b>	<b>3.96</b>	<b>6.34</b>	<b>8.71</b>	<b>9.95</b>	<b>12.33</b>	<b>14.72</b>	<b>17.11</b>	<b>19.89</b>
2.74	0.37	0.59	0.81	0.92	1.15	1.37	1.59	1.85
<b>114</b>	<b>4.19</b>	<b>6.71</b>	<b>9.23</b>	<b>10.53</b>	<b>13.06</b>	<b>15.58</b>	<b>18.11</b>	<b>21.06</b>
2.90	0.39	0.62	0.86	0.98	1.21	1.45	1.68	1.96
<b>120</b>	<b>4.43</b>	<b>7.08</b>	<b>9.74</b>	<b>11.07</b>	<b>13.72</b>	<b>16.38</b>	<b>19.04</b>	<b>22.13</b>
3.05	0.41	0.66	0.91	1.03	1.28	1.52	1.77	2.06

Ratings do not include the effect of a bird screen.

### AIR LEAKAGE

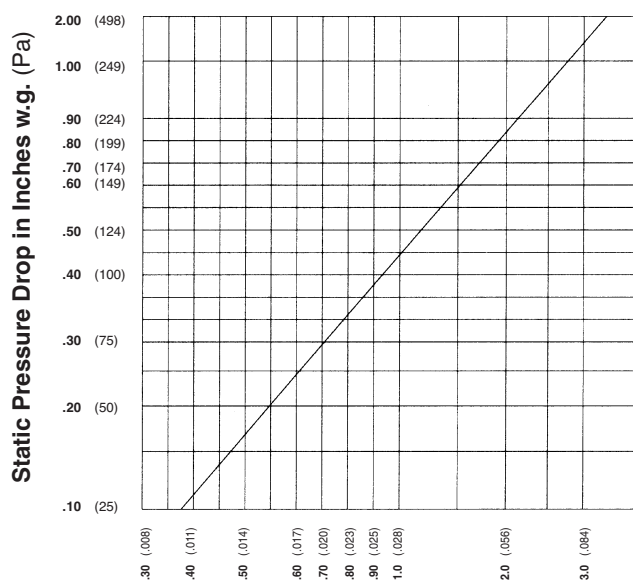

CFM (m<sup>3</sup>min.) Leakage per ft.<sup>2</sup> (m<sup>2</sup>) of Free Area

### PRESSURE DROP

Test size 48" wide x 48" high (1219 x 1219)

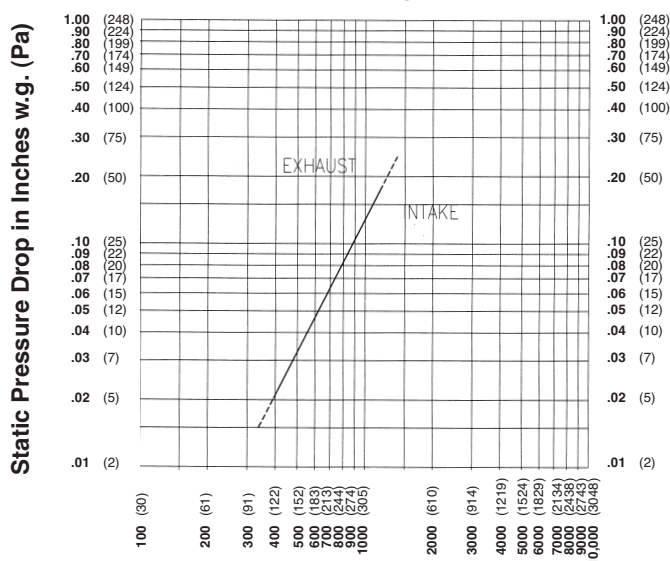

Air Velocity in feet and (meters) per minute through Free Area  
(Data corrected to standard air density and AMCA figure or figures tested to 5.5)

# FRAME CONSTRUCTION

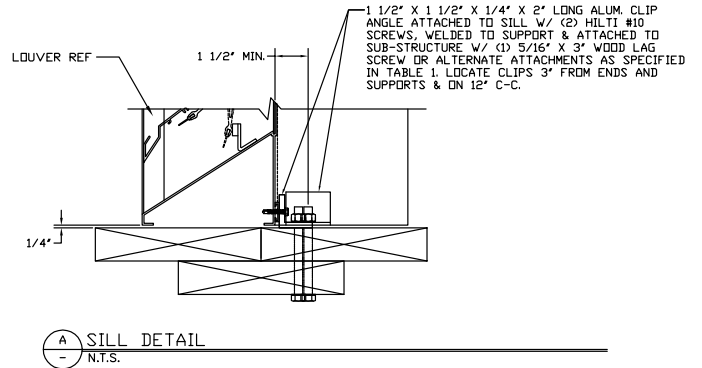
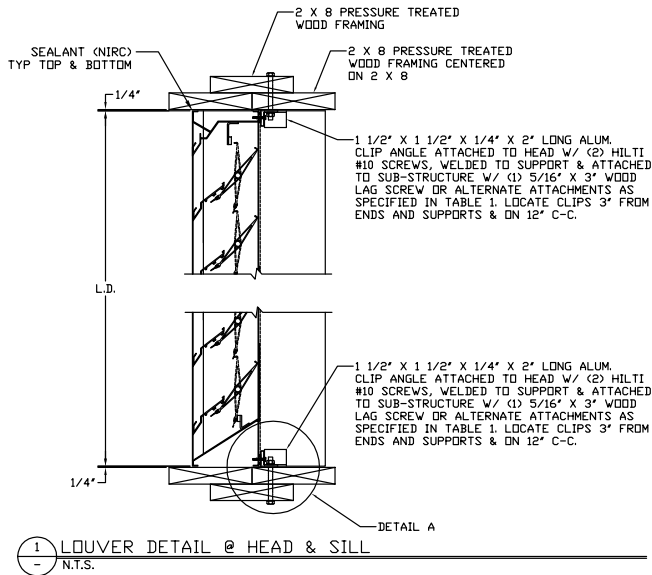
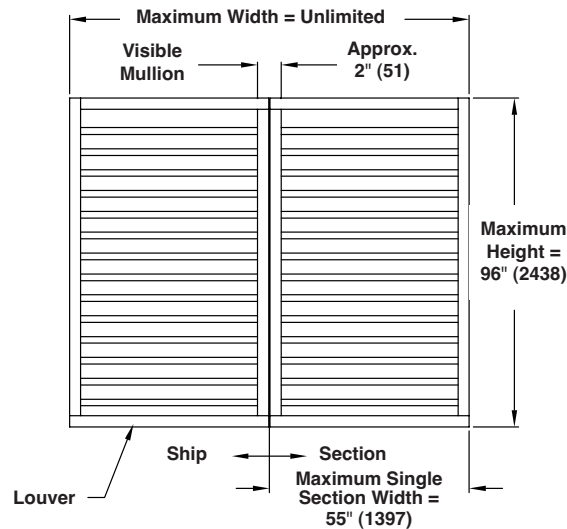

TABLE #1: ALTERNATE APPROVED ATTACHMENTS

STRUCTURAL MATERIAL	FASTENER SPECIFICATION
TIMBER	3/8" DIAMETER, 2" LONG LAG SCREW SCREW, 2" MIN EDGE DISTANCE
STEEL	3/8" SELF TAPPING SCREW OR BOLT. MINIMUM METAL THICKNESS IS 16 GA.
CONCRETE	3/8" DIA. HILTI HLC SLEEVE ANCHORS, 3" MIN. EDGE DISTANCE, 1 1/4" MIN EMBEDMENT, 2000psi MIN. CONCRETE.

NOTE: ALL FASTENERS MUST BE INSTALLED PER THE MANUFACTURER'S FLORIDA/DADE COUNTY APPROVED INSTALLATION INSTRUCTIONS



## General Notes:

- Reference separate Installation Instruction sheets (with and without optional damper) for installation details. The installation methods indicated must be complied with for Miami-Dade Approval. It is the responsibility of the installing contractor to properly install the louvers per the appropriate detail.
- On special orders, Ruskin may provide submittal and/or shop drawings. Reference these drawings for additional installation information.
- Louvers wider than the maximum single section width will be shipped in multiple sections and will require field assembly. Field assembly is not by Ruskin.
- Installation angles are shipped loose.