

AMP015 AIR MEASURING PROBE ASSEMBLY

Ruskin's AMP015 Probe assembly is designed to provide accurate flow monitoring at all times. The anodized aluminum step sensor is fastened to a 20 gauge galvanized steel mounting plate. Brass fittings are used to connect the high and low pressure chambers of the step sensor to a high performance glass on silicone pressure

transducer through 1/4" (6) O.D. polyethylene tubing. All performance data is based on three duct areas tested to AMCA 610-93 (figures one and two), providing the most comprehensive testing in the industry (refer to page 2).

STANDARD CONSTRUCTION

MOUNTING PLATE

20 ga. G60 galvanized steel.

STEP SENSOR EXTRUSION

6063T6 Extruded aluminum, clear anodized finish.

SENSOR PORT FITTINGS

1/4 Brass barbed union.

PRESSURE TUBING

Plenum Rated Polyethylene.

PRESSURE TRANSDUCER:

RU-274-R2-VDC, 0-5 or 0-10 VDC output (field selectable).
Output signal is Velocity Pressure in w.c.

POWER REQUIREMENTS

12-40 VDC or 12-35 VAC.

MINIMUM SIZE

6" w x 6" h (152 x 152) Duct.

MAXIMUM SIZE

60" w x 42" h (1524 x 1067) Duct.

VELOCITY REQUIREMENTS

Product Range - 400 to 5000 FPM.
Operating Range - 400 to 2,000 FPM.
Standard units with RU274-R2-VDC.
Operating Range - 400 to 5,000 FPM.
Units with high pressure transducer.

OPERATING TEMPERATURE

-22° F to +140° F standard.

ACCURACY

±5% measurement accuracy.



AMP015 Three Probe Assembly Shown

DUCT HEIGHT	PROBES REQUIRED
6" (152) through 12" (305)	1
13" (330) through 24" (610)	2
25" (635) through 42" (1067)	3

Ruskin Company certifies that the AMP015 Air Measuring Probe shown herein is licensed to bear the AMCA Seal - Airflow measurement station performance. The ratings shown are based on tests and procedures performed in accordance with AMCA Publication 611 and comply with requirements of the AMCA Certified Ratings Program.

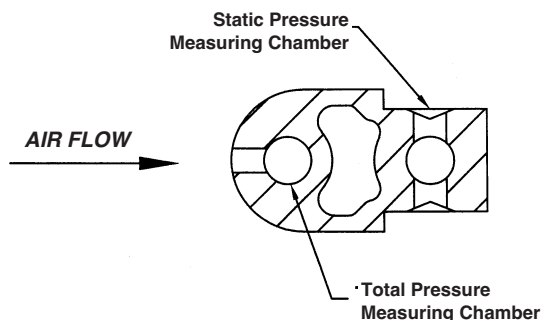
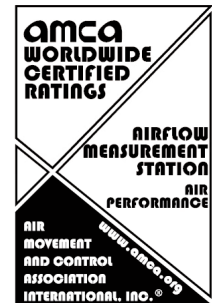

STEP SENSOR CROSS-SECTION

VARIATIONS

AMP series kits are available with an optional transducer to fit your specific application.

AMS810 Transducer with LCD Pressure Display
(field selectable 0-10 VDC or 4-20mA output)

Also use for high pressure systems over 2,000 FPM

For more information, reference the AMS810 catalog specification sheet

DPT-IQ Transmitter with 2-line Air Flow CFM Display and pressure outputs

NOTES:

1. Dimensions shown in parenthesis () indicate millimeters.
2. Refer to installation details for additional information.
3. Probe is furnished 1/4" (6) smaller than given "A" dimension.

AIR PERFORMANCE ± 5% MEASUREMENT ACCURACY

Ruskin test data is based on multiple sizes and AMCA test setup configurations. Compare data to other manufacturers that claim lower accuracy and you will find that their data is based on one size in the most favorable test configuration. Some manufacturers do

not even test to AMCA standards. You can trust Ruskin to have the most comprehensive test data in the industry so you can use our products with confidence.

AMCA TEST SETUP FIGURE 1 (Straight Duct)								AMCA TEST SETUP FIGURE 2 (After Elbow)							
TEST SIZE	TEST POINT	PAMS	REFERENCE VOLUME CFM	REFERENCE VELOCITY FPM	INDICATED VOLUME CFM	INDICATED VELOCITY FPM	% ACCURACY to REFERENCE AIRFLOW	TEST SIZE	TEST POINT	PAMS	REFERENCE VOLUME CFM	REFERENCE VELOCITY FPM	INDICATED VOLUME CFM	INDICATED VELOCITY FPM	% ACCURACY to REFERENCE AIRFLOW
12"x12" (305 x 305)	1	0.010	251	251	276	276	10.05%	12"x12" (305 x 305)	1	0.005	167	167	189	189	12.90%
	2	0.020	427	427	405	405	-5.22%		2	0.020	406	406	405	405	-0.32%
	3	0.225	1592	1592	1536	1536	-3.53%		3	0.220	1582	1582	1517	1517	-4.12%
	4	0.530	2509	2509	2462	2462	-1.86%		4	0.520	2506	2506	2437	2437	-2.77%
	5	0.875	3171	3171	3246	3246	2.36%		5	0.840	3187	3187	3174	3174	-0.42%
	6	1.390	4059	4059	4189	4189	3.19%		6	1.370	4060	4060	4155	4155	2.35%
24"x24" (610 x 610)	1	0.010	1179	295	1140	285	-3.31%	24"x24" (610 x 610)	1	0.005	894	224	806	202	-9.83%
	2	0.030	2005	501	1975	494	-1.52%		2	0.010	1103	276	1140	285	3.35%
	3	0.120	4071	1018	3949	987	-2.99%		3	0.035	2003	501	2133	533	6.48%
	4	0.450	7282	1821	7647	1912	5.02%		4	0.870	10052	2513	10633	2658	5.78%
	5	0.790	9970	2493	10133	2533	1.63%		5	1.315	13149	3287	13073	3268	-0.58%
	6	1.250	13188	3297	12746	3186	-3.35%		6	2.070	16454	4114	16402	4100	-0.32%
36"x36" (914 x 914)	1	0.005	2094	233	2135	237	1.96%	36"x36" (914 x 914)	1	0.005	2128	236	2135	237	0.33%
	2	0.050	6136	682	6375	708	3.90%		2	0.010	3110	346	2968	330	-4.58%
	3	0.090	8062	896	8429	937	4.55%		3	0.045	6109	679	6064	674	-0.74%
	4	0.480	17895	1988	18671	2075	4.34%		4	0.085	8038	893	8203	911	2.05%
	5	1.100	27799	3089	27687	3076	-0.40%		5	0.445	17709	1968	18011	2001	1.71%
	6	1.760	36618	4069	34614	3846	-5.47%		6	0.990	27880	3098	26335	2926	-5.54%

Dimensions shown in parenthesis () indicate millimeters.

AIRFLOW RESISTANCE

AMCA TEST FIGURE 1			AMCA TEST FIGURE 2		
TEST SIZE	VELOCITY	Δ PD	TEST SIZE	VELOCITY	Δ PD
12" x 12" (305 x 305)	429	0.005	12" x 12" (305 x 305)	409	0.000
	1051	0.008		1053	0.001
	1589	0.010		1579	0.004
	2506	0.012		2502	0.007
	3168	0.014		3183	0.011
	4058	0.022		4057	0.014
24" x 24" (610 x 610)	394	0.001	24" x 24" (610 x 610)	396	0.001
	620	0.002		617	0.001
	1012	0.004		991	0.003
	1995	0.011		1978	0.009
	2476	0.013		2474	0.011
	4012	0.044		4003	0.039
36" x 36" (915 x 915)	359	0.000	36" x 36" (915 x 915)	346	0.000
	682	0.005		680	0.005
	897	0.008		895	0.008
	1989	0.010		1979	0.009
	3088	0.013		3112	0.011
	4063	0.016		4300	0.017

CALCULATIONS

CFM = (K) (PAMS) ^m		
SIZE	K	M
12 x 12 (305 x 305)	3493.6	0.551
24 x 24 (610 x 610)	11400	0.500
36 x 36 (914 x 914)	26460.9	0.4751

PAMS = Velocity Pressure Across Measurement Station

Test Criteria

Model: AMP015

Method: Differential Pressure

Duct Sizes Tested: 12" x 12", 24" x 24" & 36" x 36"

Rated Duct Sized: Rectangular duct with cross-sectional areas between 0.5 and 18 square feet.

Test Setup: AMCA Standard 610, Figures 1 and 2

Ruskin Company certifies that the AMP015 Air Measuring Probe shown herein is licensed to bear the AMCA Seal - Airflow measurement station performance. The ratings shown are based on tests and procedures performed in accordance with AMCA Publication 611 and comply with requirements of the AMCA Certified Ratings Program.



AIR QUALITY SOLUTIONS

Model: AMP015

Air Measuring Probe Assembly with Pressure Transducer

PRIMARY APPLICATION

The AMP015 probe assembly is a differential pressure air measuring device that is designed to measure flow in filtered duct applications. It is intended for retrofit projects and may be installed in straight duct or in proximity to an elbow. The probes are tested in both applications and are licensed to bear the AMCA Certified ratings seal. The standard kit comes with a pressure transducer for measuring flows between 400 and 2,000 feet per minute. An optional field adjustable transducer (AMS810) is also available. The AMS810, if included, allows field selection of pressure ranges and three output options (0-5 VDC, 0-10VDC and 4-20mA). The optional AMS810 features an LCD display that shows differential pressure.

KEY FEATURES

- AMCA Certified Ratings
- Anodized Aluminum sensing probes
- Brass Barbed fittings
- Plenum Rated tubing
- RU274R2VDC Transducer

CONSTRUCTION DETAILS

Refer to Ruskin AMP015 Series Measuring Probe Assembly catalog specification sheet (Spec AMP015)

INSTALLATION

1. Remove contents from package and check to insure all parts are included.
2. Cut a 2" insertion slot in the duct.
3. On the opposite side of the insertion slot, drill 1/4" (6) holes to pass break-over tabs through.
4. Next, insert the small end of the probe assembly into the 2 (51) insertion slot. The tab on the small end of the probe should extend through the 1/4" (6) holes on the opposite side of the duct. After making sure the probe is installed correctly (reference the airflow arrow) bend the tabs over using a hammer. Fill the 1/4" (6) holes with silicone or aluminum tape.
5. Using the self-drilling mounting screws from the parts bag, secure mounting plate to the duct.
6. Bring 24 volt power supply to the transducer. Wire in accordance with the appropriate transducer installation instructions.
7. Once power is brought to the transducer and the fans are operational, use the calculations below to determine flow.

All transducers ship with a factory set range of 0-1" W.C. and an output signal set to 0-10 VDC. The output signal may be field changed to 0-5 VDC with a dip switch setting on the standard transducer (model RU274R2VDC). It can not be changed from a voltage output to a milliamp output. The optional AMS810 allows more flexibility. By changing dip switch settings, you can field select from different pressure ranges and three output options (0-10 VDC, 0-5 VDC or 4-20 mA). Refer to the transducer catalog data sheets for further information.

CALCULATIONS

The following K factors may be used in any of the formulas below.

Single Probe Applications: K=3493 M=0.551

Two Probe Applications: K=2850 M=0.500

Three Probe Applications: K=2940 M=0.4751

FORMULAS FOR RU274R2VDC TRANSDUCERS

The following equations can be used to calculate the velocity from each of the pressure transducer output signals (output scaled .01 - 1" w.c.):

$$0-10 \text{ VDC: } CFM = (Area \times K) \times (VDC \times .1)^M$$

$$0-5 \text{ VDC: } CFM = (Area \times K) \times (VDC \times .2)^M$$

$$4-20 \text{ mA: } CFM = (Area \times K) \times (mA \times .0625 \text{ } -.25)^M$$

FORMULAS FOR AMS810 TRANSDUCERS

To calculate CFM using the LCD display of the AMS810 pressure transducer, read the differential pressure (DP) from the LCD display and enter the DP into the following equation:

$$CFM = (K \times Area) DP^M$$

Where:

K = Proprietary constant value based on test data

Area = Duct width times duct height over 144

DP = Differential Pressure

M = Proprietary power based on test data

Or

The following equations can be used to calculate the velocity from each of the pressure transducer output signals (output scaled .01 - 1" w.c.):

$$0-10 \text{ VDC: } CFM = (Area \times K) \times (VDC \times .1)^M$$

$$0-5 \text{ VDC: } CFM = (Area \times K) \times (VDC \times .2)^M$$

$$4-20 \text{ mA: } CFM = (Area \times K) \times (mA \times .0625 \text{ } -.25)^M$$

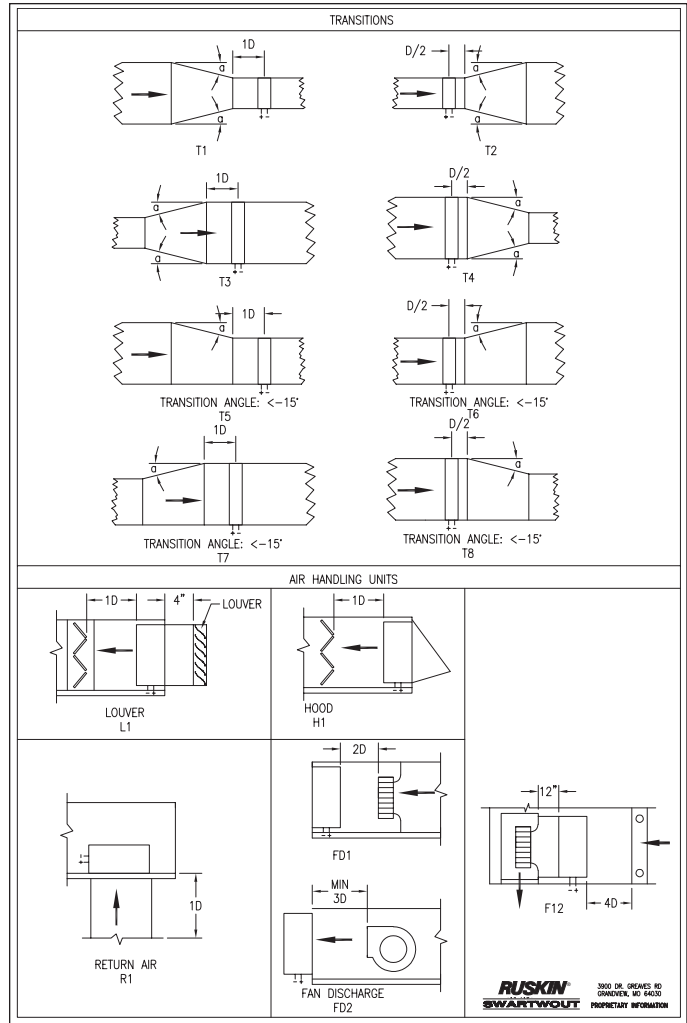
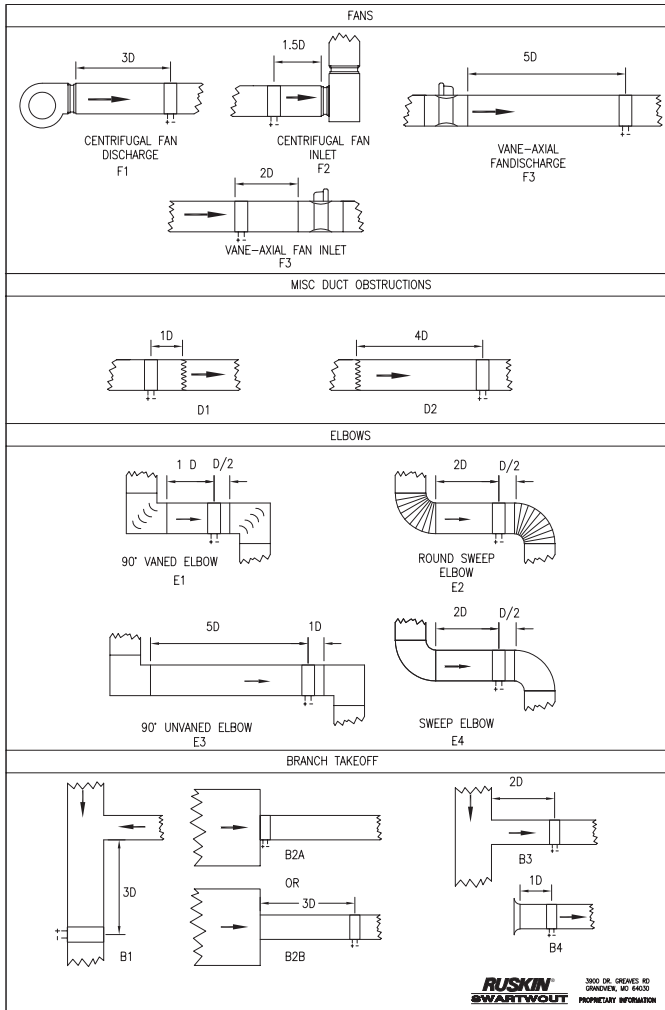

		1D EQUIVALENT CHART																												
		DUCT WIDTH																												
DUCT HEIGHT		6	8	10	12	14	16	18	20	22	24	26	28	30	32	34	36	38	40	42	44	46	48	50	52	54	56	58	60	
	6		6.8	7.8	8.7	9.6	10	11	12	12	13	14	14	15	15	16	16	17	17	18	18	19	19	20	20	20	20	21	21	21
8		7.8	9	10	11	12	13	14	14	15	16	16	17	17	18	19	19	20	20	21	21	22	22	23	23	24	24	24	25	25
10		8.7	10	11	12	13	14	15	16	17	17	18	19	20	20	21	22	23	24	24	25	26	27	27	28	28	29	29	29	28
12		9.6	11	12	14	15	16	17	17	18	19	20	21	21	22	23	24	25	25	26	27	27	28	28	29	29	30	30	30	30
14		10	12	13	15	16	17	18	19	20	21	22	22	23	24	25	25	26	27	27	28	29	29	30	30	31	32	32	33	33
16		11	13	14	16	17	18	19	20	21	22	23	24	25	26	26	27	28	29	29	30	31	31	32	33	33	34	34	35	35
18		12	14	15	17	18	19	20	21	22	23	24	25	26	27	28	29	30	30	31	32	32	33	34	35	35	36	36	37	37
20		12	14	16	17	19	20	21	23	24	25	26	27	28	29	29	30	31	32	33	33	34	35	36	36	37	38	38	39	39
22		13	15	17	18	20	21	22	24	25	26	27	28	29	30	31	32	33	33	34	35	36	37	37	38	39	40	40	41	41
24		14	16	17	19	21	22	23	25	26	27	28	29	30	31	32	33	34	35	36	37	37	38	39	40	41	41	42	43	43
26		14	16	18	20	22	23	24	26	27	28	29	30	32	33	34	35	35	36	37	38	39	40	41	41	42	43	44	44	45
28		15	17	19	21	22	24	25	27	28	29	30	32	33	34	35	36	37	38	39	40	40	41	42	43	44	45	45	46	46
30		15	17	20	21	23	25	26	28	29	30	32	33	34	35	36	37	38	39	40	41	42	43	44	45	45	46	47	48	48
32		16	18	20	22	24	26	27	29	30	31	33	34	35	36	37	38	39	40	41	42	43	44	45	46	47	48	49	49	49
34		16	19	21	23	25	26	28	29	31	32	34	35	36	37	38	39	41	42	43	44	45	46	47	48	49	50	51	51	51
36		17	19	21	23	25	27	29	30	32	33	35	36	37	38	39	41	42	43	44	45	46	47	48	49	50	51	52	52	52
38		17	20	22	24	26	28	30	31	33	34	35	37	38	39	41	42	43	44	45	46	47	48	49	50	51	52	53	54	54
40		17	20	23	25	27	29	30	32	33	35	36	38	39	40	42	43	44	45	46	47	48	49	50	51	52	53	54	55	55
42		18	21	23	25	27	29	31	33	34	36	37	39	40	41	43	44	45	46	47	49	50	51	52	53	54	55	56	57	57
44		18	21	24	26	28	30	32	33	35	37	38	40	41	42	44	45	46	47	49	50	51	52	53	54	55	56	57	58	58
46		19	22	24	27	29	31	32	34	36	37	39	40	41	42	44	45	46	47	48	50	51	52	53	54	55	56	57	58	59
48		19	22	25	27	29	31	33	35	37	38	40	41	43	44	46	47	48	49	51	52	53	54	55	56	57	59	60	61	61
50		20	23	25	28	30	32	34	36	37	39	41	42	44	45	47	48	49	50	52	53	54	55	56	58	59	60	61	62	62
52		20	23	26	28	30	33	35	36	38	40	41	43	45	46	47	49	50	51	53	54	55	56	58	59	60	61	62	63	63
54		20	23	26	29	31	33	35	37	39	41	42	44	45	47	48	50	51	52	54	55	56	57	59	60	61	62	63	64	64
56		21	24	27	29	32	34	36	38	40	41	43	45	46	48	49	51	52	53	55	56	57	59	60	61	62	63	64	65	65
58		21	24	27	30	32	34	36	38	40	42	44	45	47	49	50	52	53	54	56	57	58	60	61	62	63	64	65	67	67
60		21	25	28	30	33	35	37	39	41	43	45	46	48	49	51	52	54	55	57	58	59	61	62	63	64	65	67	68	68

To determine the placement of an air measuring probe that is located down stream of a 90° vaned elbow (as shown in the detail E1 above); follow the duct width down to the duct height. The number at this intersection represents distance in inches (1D).

Example 1
The 1D Equivalent of a 20" x 10" duct = 16"

Example 2
The same 20" x 10" duct installed as shown in detail E3 would be 16" x 5 (5D)

- Notes:**
- All numbers are expressed in inches.
 - 2D = 1D x 2, 3D = 1D x 3, etc.

INSTALLATION DETAILS

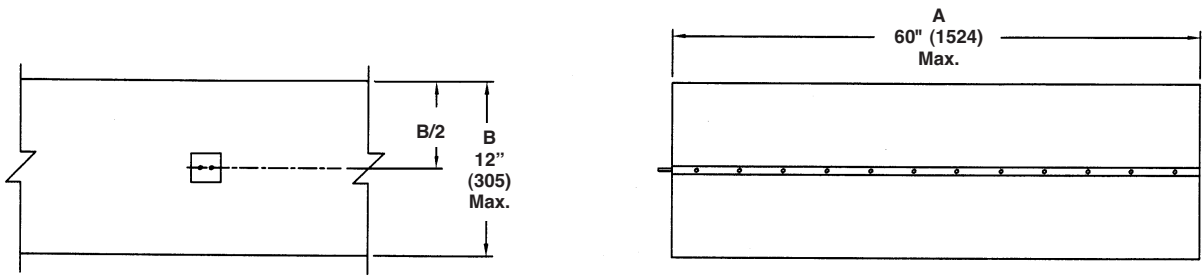

AMP015 Single Probe Applications from 6" to 60" A-Width x 6" to 12" B-Height

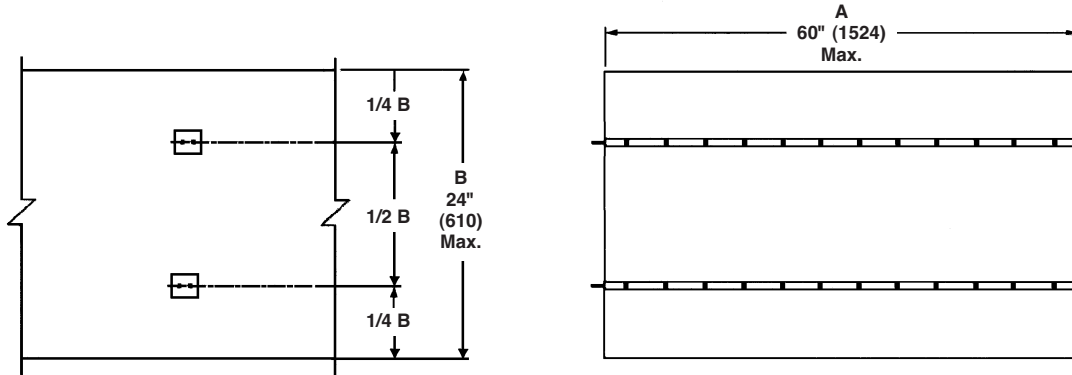

AMP015 Two Probe Applications from 6" to 60" A-Width x 12" to 24" B-Height

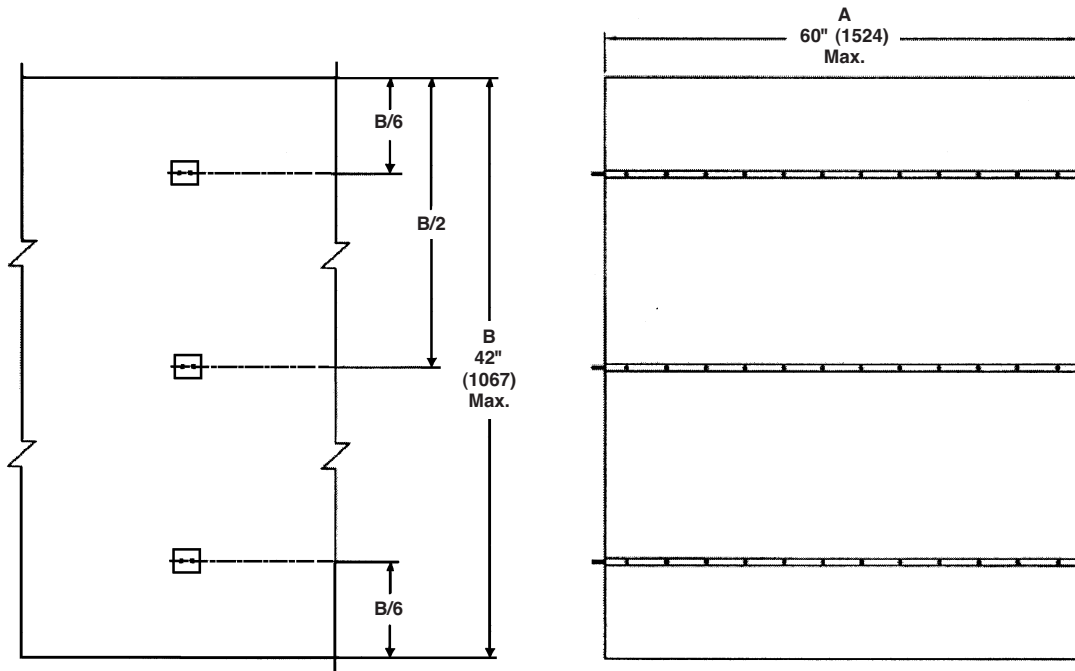

AMP015 Three Probe Applications from 6" to 60" A-Width x 24" to 42" B-Height

ORDERING INFORMATION

Model	Description
AMP015	Probe Assembly

Ordering Instructions:

1. Specify quantity, model, "A" duct/probe width* and "B" duct/probe height*
2. Refer to Installation Details for probe placement.

AMP015 Probe Assembly Contents

Step Sensor Probe(s)
Brass "T" Fittings
Rubber Brass Fitting Caps
High & Low Pressure Tubing
RU-274-R2-VDC Pressure Transducer (factory piped and mounted)
Installation Instructions

SPECIFICATION

Furnish and install, at locations shown on plans or as in accordance with schedules, an air measuring probe system piped to a high performance pressure transducer. Assembly shall be AMCA tested and licensed to bear the airflow measurement station air performance seal and be capable of measuring a range from 400 to 5,000 feet per minute. The Air measuring assembly shall measure to $\pm 5\%$ average and consist of 6063T6 extruded aluminum step sensing blade(s) with anodized finish, plenum rated polyethylene pressure tubing, brass barbed pressure fittings, mounting hard-

ware and a glass-on-silicone GL-Si capacitance sensor pressure transducer capable of measuring up to six field selectable pressure ranges up to 1" water column. The transducer shall be accurate to $\pm 1\%$ of full scale and be contained in a NEMA 4 (IP-65) painted steel enclosure. Transducer shall be factory mounted and piped to high and low brass pressure fittings from the sensor averaging ports. All sensor tubing shall terminate in solid brass barbed fittings. Air Measuring Probe Assembly shall be, in all respects, equivalent to Ruskin Model AMP015.

RUSKIN[®]

3900 Dr. Greaves Rd.
Kansas City, MO 64030
(816) 761-7476
FAX (816) 765-8955
www.ruskin.com