

<sup>®</sup>  
**Dayton**



## **Belt-Drive Utility Exhaust Blowers**

**Models 1WBW8, 1WBW9, 1WBX1, 1WBX2,  
5ZPJ8, 5ZPJ9, 5ZPK0, 5ZPK1, 20CK87,  
20CK88**

®  
**Dayton**

**PLEASE READ AND SAVE  
THESE INSTRUCTIONS.**

**READ CAREFULLY  
BEFORE ATTEMPTING  
TO ASSEMBLE, INSTALL,  
OPERATE OR MAINTAIN THE  
PRODUCT DESCRIBED.**

**PROTECT YOURSELF AND  
OTHERS BY OBSERVING ALL  
SAFETY INFORMATION. FAILURE  
TO COMPLY WITH INSTRUCTIONS  
COULD RESULT IN PERSONAL  
INJURY AND/OR PROPERTY  
DAMAGE! RETAIN INSTRUCTIONS  
FOR FUTURE REFERENCE.**

**PLEASE REFER TO BACK COVER  
FOR INFORMATION REGARDING  
DAYTON'S WARRANTY AND OTHER  
IMPORTANT INFORMATION.**

**Model #:** \_\_\_\_\_

**Serial #:** \_\_\_\_\_

**Purch. Date:** \_\_\_\_\_

*Form 5S6729 / Printed in USA  
04632 Version 1 04/2014*

**© 2006 - 2014 Dayton Electric Manufacturing Co.  
All Rights Reserved**

## BEFORE YOU BEGIN

### **⚠ WARNING**

**Installation, troubleshooting and parts replacement are to be performed only by qualified personnel.**



### **Electrical Requirements:**

- The motor voltage and ampere rating must be checked for compatibility with the electrical supply prior to final electrical connection. Supply wiring to the fan must be properly fused, and conform to local and national electrical codes.



### **Tools Needed:**

- Drill
- Level
- Multimeter
- Tape Measure
- Lock-Out Tag-Out
- Hex Keys/Wrench

## UNPACKING



### **Contents:**

- Dayton® Utility Exhaust Belt-Drive Blower (1)
- Operating Instructions and Parts Manual (1)



### **Inspect:**

- After unpacking unit, inspect carefully for any damage that may have occurred during transit. Check for loose, missing, or damaged parts. Shipping damage claim must be filed with carrier.
- Check all bolts, screws, set-screws, etc. for looseness that may have occurred during transit. Retighten as required. Rotate blower wheel by hand to be sure it turns freely.
- **See General Safety Instructions on page 2, and Cautions and Warnings as shown.**



## GENERAL SAFETY INSTRUCTIONS

Utility Exhaust Blowers are designed for commercial kitchen exhaust or industrial spark resistant applications requiring high volumes of air at high static pressures. Units are suitable for ducted exhaust, supply and return-air applications. All blowers are UL/cUL Listed Subject 762 (YZHW) and comply with all requirements set forth in NFPA 96 Standard for Ventilation Control and Fire Protection Commercial Cooking Operations. Hazardous Location Motors are offered for many single and three phase blower combinations.

**NOTE:** Blower is only permissible for UL 762 when mounted outside of the building, scroll must remain in upblast position for proper grease draining.

**⚠ DANGER** *Do not depend on any switch as the sole means of disconnecting power when installing or servicing the blower. Always disconnect, lock and tag power source before installing or servicing. Failure to disconnect power source can result in fire, shock or serious injury. Motor will restart without warning after thermal protector trips. Do not touch operating motor, it may be hot enough to cause injury.*

**⚠ DANGER** *Do not place any body parts or objects in blower, motor openings or drives while motor is connected to power source.*

**⚠ WARNING** *Do not use this equipment in explosive atmospheres.*

1. Read and follow all instructions and cautionary markings. Make sure electrical power source conforms to requirements of equipment and local codes.
2. Blowers should be assembled, installed and serviced by a qualified technician. Have all electrical work performed by a qualified electrician.
3. Follow all local electrical and safety codes in the United States, as well as the National Electrical Code (NEC) and National Fire Protection Agency (NFPA) where applicable. Follow the Canadian Electric Code (CEC) in Canada.
4. The rotation of the wheel is critical. It must be free to rotate without striking or rubbing any stationary objects.
5. Unit must be securely and adequately grounded.
6. Do not spin blower wheel faster than max cataloged fan RPM. Adjustments to fan speed significantly affects motor load. If the blower RPM is changed, the motor current should be checked to make sure it is not exceeding the motor nameplate amps.
7. Do not kink power cable or allow it to come in contact with sharp objects, oil, grease, hot surfaces or chemicals. Replace damaged cords immediately.
8. Make certain that the power source conforms to the requirements for the equipment.
9. Never open access door to a duct with the ventilator running.

## SPECIFICATIONS

### 1WBW8, 1WBW9, 1WBX1, 1WBX2, 5ZPJ8, 5ZPJ9, 5ZPK0, 5ZPK1, 20CK87, 20CK88

Max. Inlet Temp.	300°F
Mounting Location	Outdoor (UL 762), Indoor (UL 705)
Recommended NEMA 1 Disconnect Switch	1H400 (2 pole, 115/230V, 2 HP max)
	1H401 (3 pole, 230V, 7-1/2 HP max)
	1H401 (3 pole, 460V, 10 HP max)
Recommended NEMA 4 Disconnect Switch	1H408 (2 pole, 115/230V, 2 HP max)
	1H409 (3 pole, 230V, 7-1/2 HP max)
	1H409 (3 pole, 460V, 10 HP max)
Agency Compliance	UL/cUL 762, AMCA Air

### Dimensions (inches)

	20CK87 20CK88	5ZPJ8	1WBW8	5ZPJ9	1WBW9	5ZPK0	1WBX1	5ZPK1	1WBX2
A	11	13	14	15-5/8	17-1/2	19-1/4	21-1/8	23	25-7/8
B	9-3/4	9-5/8	10-5/8	11-5/8	12-3/4	14-1/8	15-3/8	17	19
C	15-1/2	15-1/2	16-3/4	18-1/2	19-1/2	22	23-3/4	24	25
E	22-1/4	22 1/4	24-3/4	27-1/2	30	33-1/4	36-1/8	41-1/2	45-3/4
F	21-7/8	21-3/8	22-1/2	24-1/8	28-1/4	32-1/4	35	34-1/8	36
G	11-1/4	13	14-1/4	15-3/4	17-1/2	19-3/8	21-5/8	23-1/2	26
H	11-1/2	13-1/4	14-5/8	16-1/4	17-3/4	19-5/8	21-1/2	23-3/4	26-1/4
J	20-1/8	23-3/16	25-1/2	28-3/8	31	34-1/4	37-5/8	41-7/16	45-7/8
K	8-5/8	9-3/4	10-5/8	11-5/8	12-1/2	13-3/4	14-7/8	16-1/4	17-3/4
M	15-1/8	15-1/8	16-5/8	18-1/2	20-3/8	22-3/8	24-1/2	28-3/4	31-1/2
N	16	16	17-5/8	20	21-3/8	23-3/8	25-5/8	28-1/4	31-1/8
Wheel Dia.	11-1/8	12-1/4	13-1/2	15	16-1/2	18-1/4	20	22-1/4	24-1/2
Shaft Dia.	3/4	1	1	1-1/4	1-1/4	1-1/4	1-1/4	1-1/2	1-1/2

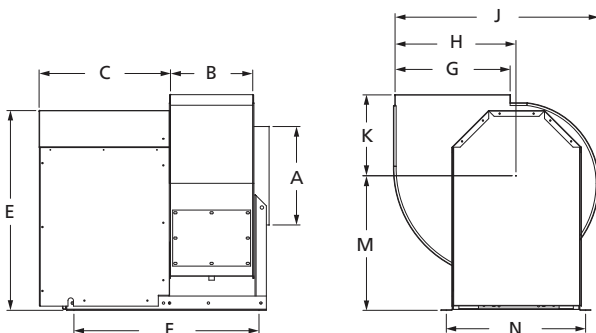

Figure 1



E53236  
MH12596 – For Exterior use only in  
UL 762 installations



Dayton Electric Mfg. Co. certifies that the blowers shown herein are licensed to bear the AMCA seal. The ratings shown are based on tests and procedures performed in accordance with AMCA Publication 211 and comply with the requirements of the AMCA Certified Ratings Program.

**PERFORMANCE**

Model	HP	RPM	Max BHP	CFM Air Delivery @ RPM Shown					
				0.25"	0.50"	0.75"	1.00"	2.00"	3.00"
20CK87	1/4	2048	0.25	893	836	771	696	—	—
	1/3	2246	0.33	989	938	882	819	494	—
	1/2	2581	0.50	1151	1106	1061	1011	769	—
	3/4	2949	0.75	1326	1288	1249	1209	1018	778
	1	3245	1.00	1467	1432	1397	1361	1199	1005
20CK88	1/4	1400	0.15	1015	893	737	—	—	—
	1/4	1670	0.25	1246	1158	1047	922	—	—
	1/3	1833	0.33	1383	1307	1251	1109	—	—
	1/2	2103	0.5	1608	1542	1472	1389	788	—
	3/4	2408	0.75	1861	1802	1744	1681	1359	—
	1	2650	1.00	2060	2005	1953	1900	1629	1237
	1-1/2	3033	1.50	2373	2323	2277	2232	2024	1764
	2	3346	2.00	2628	2582	2539	2498	2322	2100
	5ZPJ8	1/4	1501	0.25	1444	1324	1176	968	—
1/3		1643	0.33	1597	1495	1376	1226	—	—
1/2		1889	0.50	1862	1783	1683	1578	—	—
3/4		2159	0.75	2151	2081	2004	1917	1448	—
1		2373	1.00	2379	2311	2253	2172	1806	1024
1-1/2		2716	1.50	2741	2681	2626	2574	2293	1928
2		2991	1.98	3030	2976	2921	2875	2635	2335
1WBW8	1/4	1261	0.25	1671	1509	1309	—	—	—
	1/3	1384	0.33	1862	1720	1559	1351	—	—
	1/2	1589	0.50	2176	2056	1926	1783	—	—
	3/4	1819	0.75	2522	2419	2311	2196	1395	—
	1	2002	1.00	2795	2703	2607	2507	2011	—
	1-1/2	2292	1.50	3224	3145	3062	2979	2607	2015
	2	2522	2.00	3562	3491	3418	3342	3018	2618
	3	2892	3.00	4105	4042	3980	3915	3645	3347
5ZPJ9	1/4	1060	0.25	1902	1681	1373	—	—	—
	1/3	1161	0.33	2119	1926	1694	1268	—	—
	1/2	1333	0.5	2483	2322	2144	1933	—	—
	3/4	1526	0.75	2885	2748	2602	2443	—	—
	1	1680	1	3201	3078	2950	2814	2007	—
	1-1/2	1923	1.5	3696	3591	3482	3368	2847	—
	2	2116	2	4087	3993	3894	3794	3352	2730
	3	2423	3	4706	4623	4540	4453	4091	3670

Performance certified is for installation type B: Free inlet, Ducted outlet. Power rating (BHP) does not include transmission losses. Performance ratings do not include the effects of appurtenances (accessories). The AMCA Certified ratings Seal applies to air performance ratings only.

Model	HP	RPM	Max BHP	CFM Air Delivery @ RPM Shown					
				0.25"	0.50"	0.75"	1.00"	2.00"	3.00"
1WBW9	1/2	1125	0.5	2808	2600	2354	1988	—	—
	3/4	1288	0.75	3270	3093	2899	2677	—	—
	1	1418	1.00	3633	3473	3312	3125	—	—
	1-1/2	1624	1.5	4203	4066	3925	3782	2973	—
	2	1785	2.00	4645	4521	4393	4268	3647	—
	3	1900	2.42	4959	4844	4724	4604	4061	3201
	3	2041	3.00	5344	5237	5127	5014	4538	3893
	5	2378	4.7	6259	6168	6075	5981	5604	5148
5ZPK0	1/4	754	0.25	2400	1952	—	—	—	—
	1/3	828	0.33	2696	2341	1668	—	—	—
	1/2	950	0.50	3176	2894	2540	1864	—	—
	3/4	1087	0.75	3706	3479	3206	2880	—	—
	1	1197	1.00	4125	3916	3690	3437	—	—
	1-1/2	1370	1.50	4777	4595	4415	4208	2904	—
	2	1508	2.00	5292	5128	4962	4799	3904	—
	3	1725	3.00	6097	5956	5811	5666	5008	3976
	5	2046	4.99	7280	7161	7041	6919	6418	5822
1WBX1	3/4	935	0.75	4164	3863	3506	3005	—	—
	1	1027	1.00	4629	4362	4057	3703	—	—
	1-1/2	1176	1.50	5372	5138	4904	4627	—	—
	2	1295	2.00	5960	5749	5537	5309	3996	—
	3	1482	3.00	6876	6695	6508	6324	5435	3335
	5	1756	5.00	8208	8057	7903	7745	7079	6257
	7-1/2	1950	6.78	9146	9010	8874	8733	8173	7500
5ZPK1	1/4	573	0.25	3057	2063	—	—	—	—
	1/3	621	0.33	3409	2707	—	—	—	—
	1/2	715	0.50	4059	3584	2730	—	—	—
	3/4	816	0.75	4746	4365	3862	3005	—	—
	1	897	1.00	5285	4958	4563	4039	—	—
	1-1/2	1028	1.50	6147	5857	5557	5206	—	—
	2	1131	2.00	6819	6558	6296	6002	3894	—
	3	1294	3.00	7866	7642	7415	7188	5956	—
5	1535	5.00	9402	9224	9030	8841	7998	6788	
1WBX2	1	751	1.00	6075	5610	5051	4330	—	—
	1-1/2	859	1.50	7059	6674	6238	5738	—	—
	2	944	2.00	7824	7485	7120	6692	—	—
	3	1081	3.00	9045	8768	8452	8128	6420	—
	5	1281	5.00	10,813	10,580	10,339	10,072	8870	7188
	7-1/2	1468	7.50	12,461	12,252	12,048	11,834	10,868	9708
10	1588	9.42	13,516	13,318	13,129	12,941	12,089	11,074	

## INSTALLATION INSTRUCTIONS

**⚠ WARNING** *Installation, troubleshooting and parts replacement are to be performed only by qualified personnel. Consult and follow NFPA 96 recommendations. NFPA 96 instructions supersede this document.*

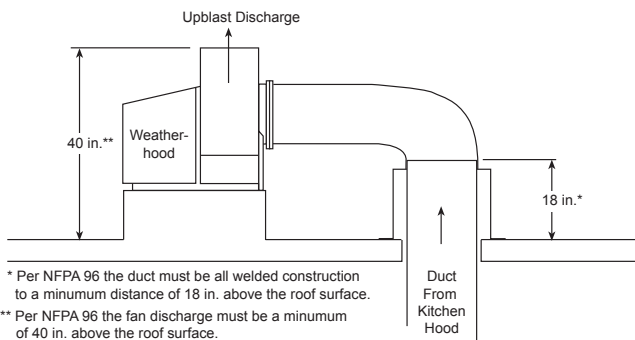

\* Per NFPA 96 the duct must be all welded construction to a minimum distance of 18 in. above the roof surface.

\*\* Per NFPA 96 the fan discharge must be a minimum of 40 in. above the roof surface.

**Figure 2**

- This Dayton blower is assembled and shipped in the upblast position. If another position is desired refer to Figure 3 (viewed from drive side) for optional discharge positions.

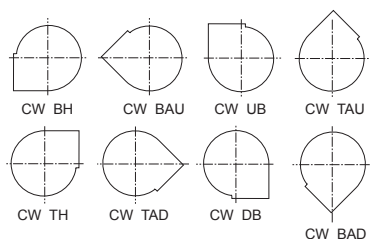

**Figure 3**

**NOTE:** For Top Angular Down, Downblast and Bottom Angular Down discharge positions, a portion of the frame angle must be removed.

**NOTE:** Changing the discharge position will relocate the access door and drain connection. NFPA 96 requires the drain connection be placed at the lowest point of the scroll to discard water and grease. Additionally, UL does not permit these blowers to be used in the downblast positions for kitchen or grease applications.

- To rotate the scroll you will have to remove a total of sixteen fasteners. Eight fasteners are located on the intake side and the other eight are located on the tall vertical support behind the weather hood.
  - Position the scroll in the desired position. Line up holes and refasten with the same bolts you previously removed.
- Locate and prepare roof area for blower. Blower should be securely fastened to the roof deck, roof joist, or equipment supports through the mounting holes provided in the base angles. If equipment supports are being used they should be fastened to the roof as well.



3. Restricted or unstable flow at the fan inlet can cause pre-rotation of incoming air or uneven loading of the fan wheel, yielding large system losses, increase sound levels and structural failure of the blower wheel. Free discharge or turbulent flow in the discharge ductwork will also result in system effect losses. The examples in Figure 4 show the system layout and inlet and discharge configurations which can affect blower performance.

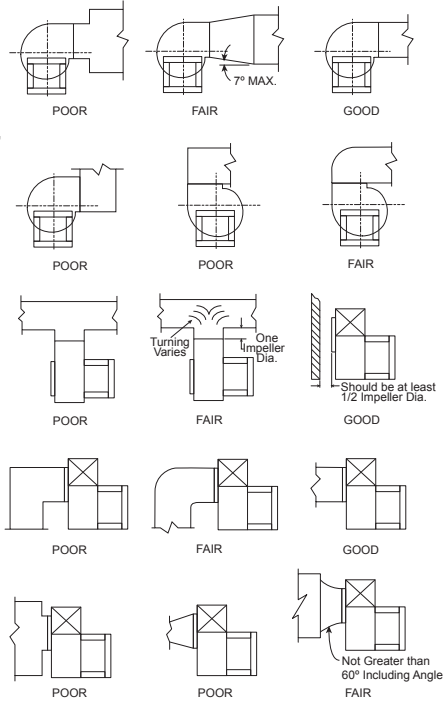

**NOTE:** Inlet duct should be straight for a minimum of 2-1/2" wheel diameters prior to connecting to the blower.

**Figure 4**

4. Attach inlet duct to the inlet collar of the blower. NFPA 96 requires the inlet duct connection and duct to be fully welded in kitchen exhaust applications. Refer back to Figure 2 for minimum duct and blower discharge heights.
5. Replace access door using same bolts that were removed previously.
 

**NOTE:** The drain connection will no longer operate if housing is rotated to another position. In this case, leave the plug installed to minimize air loss.
6. Rotate the wheel by hand to ensure that it does not rub and rotates freely. Refer to Figures 5 and chart for proper overlap and radial gap dimensions.
  - a. Centering can be accomplished by loosening the inlet cone bolts to move the inlet cone or by loosening the bearings in order to move the shaft.
  - b. Wheel and inlet cone overlap can be adjusted by loosening the wheel hub set screws and moving the wheel to the desired position. Tighten all fasteners and set screws securely.

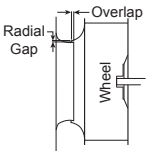

**Figure 5**

	Wheel Diameter	
	11-1/8 thru 16-1/2	18-1/4 thru 24-1/2
Overlap (inches)	1/4	5/32
Radial Gap (inches)	3/8	5/32



## MOTOR AND PULLEY MOUNTING

**⚠ CAUTION** *Never adjust pitch of wheel blades in field. Blade pitch should only be changed by manufacturer.*

**NOTE:** For UL/cUL Listed units, the motor used with this fan must be designated as such by Dayton®.

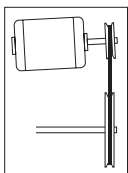

Wrong

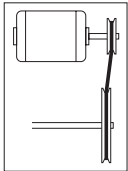

Wrong

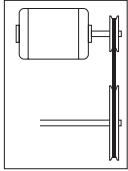

Right

**Figure 6**

- Secure motor to plate (hardware by others). Holes will align when the motor frame (shaft end) is flush with the edge of the motor plate. Refer to UL/cUL motor label attached to unit.
- Mount pulleys on shafts and secure with set screw. Check pulleys for proper alignment, see Figure 6. Misaligned pulleys lead to excessive belt wear, vibration and noise.
- Install the belt and adjust the tension to allow for 1/64" of deflection per inch of span when moderate thumb pressure is applied to the belt. Adjust belt using the motor plate adjusting brackets as shown in Figure 7. Too much tension will cause excess bearing wear and noise. Too little tension will cause slippage at startup and uneven wear.

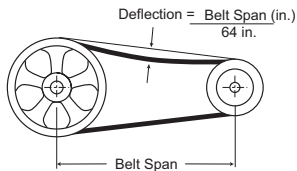

**Figure 7**

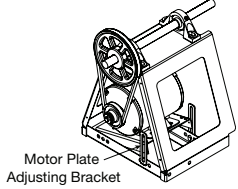

**Figure 8**

- Adjust RPM to desired level using a variable pitch pulley. After adjustment, motor amperage should be checked to avoid overloading of the motor.

## Electrical connection

**NOTE:** Refer to motor nameplate for wiring procedures. Refer to switch manufacturer for installation and wiring procedures.

**To reduce the risk of electrical shock - do not connect to a circuit operating at more than 150V to ground.**

**⚠ WARNING**

- Motor and fan must be securely grounded (bare metal) to a suitable electric ground, such as a grounded water pipe or ground wire system.
- Wire motor for desired voltage per wiring diagram on motor or refer to Figure 9 for connection wiring diagram.

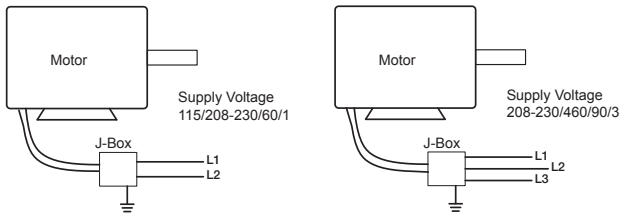

**Figure 9**

## OPERATION

1. Before starting up or operating your new Dayton® blower, check all fasteners for tightness. In particular, check bearing set screws in wheel (and sheaves, if applicable). While in the OFF position, or before connecting the blower to power, turn the blower wheel by hand to be sure it is not striking the orifice or any obstacle.
2. Start the blower up and shut it off immediately to check rotation of the wheel with directional arrow in the motor compartment.
  - a. Rotation of the wheel is critical and incorrect rotation will result in reduced air performance, increased motor loading and possible motor burnout.
  - b. Remove access door.
  - c. Check wheel rotation by momentarily energizing the unit and note if rotation is in the same direction as the airflow at the outlet and conforms to the rotation decal affixed to the blower or refer to Figure 10.

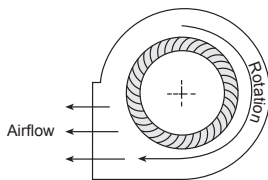

**Figure 10**

4. When the blower is started, observe the operation and check for any unusual noises.
5. With the system in full operation measure current input to the motor and compare with the nameplate rating to determine if the BHP is operating under safe load conditions.
6. Adjust RPM to desired level using a variable pitch pulley. After adjustment, motor amperage should be checked to avoid overloading of the motor.

**IMPORTANT:** Adjust (tighten) belt tension after the first 24 hours of operation.

7. Keep inlets and approaches to blower clean and free from obstruction.

## TROUBLESHOOTING GUIDE

Symptom	Possible Cause(s)	Corrective Action
Blower inoperative	1. Electrical Supply	1. Check fuses/circuit breakers. Check for switches off. Check for correct supply voltage.
	2. Drive	2. Check for broken belts. Tighten loose pulleys.
	3. Motor	3. Assure motor is correct horsepower and not tripping overload protector.
Excessive noise or vibration	1. Wheel Rubbing Inlet	1. Adjust wheel and/or inlet cone. Tighten wheel hub or bearing collars on shaft.
	2. V-Belt Drive	2. Tighten sheaves on motor/fan shaft. Adjust belt tension. Align sheaves properly (see page 8). Replace worn belts or sheaves.
	3. Bearings	3. Replace defective bearing(s). Lubricate bearings. Tighten collars and fasteners.
	4. Wheel Unbalance	4. Clean all dirt off wheel. Check wheel balance, rebalance in place if necessary.
Insufficient airflow	1. Blower	1. Check wheel for correct rotation. Increase fan speed.*
	2. Duct System	2. See page 7, Figure 4.
Too much airflow	1. Blower	1. Re-size ductwork. Access door, filters, grills not installed.
	2. Duct System	2. Change obstructions in system. Use correction factor to adjust for temperature/altitude. Re-size ductwork. Clean filters/coils. Adjust fan speed.*
Static pressure incorrect	Duct system has more or less restriction than anticipated	Check rotation of wheel. Adjust fan speed.
Overheated bearings	1. Lubrication	1. Check for excessive or insufficient grease in the bearing.
	2. Mechanical	2. Replace damaged bearing. Relieve excessive belt tension. Align bearings. Check for bent shaft.
Motor overloads or overheats	1. Blower	1. Check rotation of wheel. Reduce fan speed.
	2. Duct System	2. Re-size ductwork. Check proper operation of face and bypass dampers. Check filters and access doors.

\* Always check motor amps and compare to nameplate rating. Excessive fan speed may overload the motor and result in burnout.

## MAINTENANCE

### **▲ WARNING**

**Disconnect and lockout power source before servicing.**

### **▲ CAUTION**

**Uneven cleaning of the wheel will produce an out of balance condition that will cause vibration in the fan.**

1. Depending on the usage and severity of the contaminated air, a regularly scheduled inspection for cleaning the blower wheel, housing and surrounding areas should be established.
2. Check for unusual noises when blower is running.
3. Periodically inspect and tighten set-screws.
4. Periodically check belts for wear and tightness.

**NOTE:** When replacing belts use the same type as supplied with the unit.

**NOTE:** For belt replacement, loosen the motor mounting hardware to allow removal of the belt by hand.

### **▲ CAUTION**

**Do not force belts on or off. This may cause cords to break, leading to premature belt failure.**

5. All blower bearings are pre-lubricated. Keep bearings clean and well lubricated.

**NOTE:** Sealed pillow block bearings require no further lubrication.

### **Recommended Relubrication Frequency in Months**

Blower RPM	Bearing Bore (inches)		Blower RPM	Bearing Bore (inches)	
	1/2 to 1	3/4 to 1-1/2		1/2 to 1	3/4 to 1-1/2
To 250	12	12	1500	12	5
500	12	12	2000	12	3
750	12	9	2500	12	2
1000	12	7	3000	12	2
1250	12	6	3500	12	1
Number of Shots	4	8	Number of Shots	4	8

- a. Lubricant should be added with the shaft rotating and until clean grease is seen purging from the bearing. The lubrication interval may be modified based on the condition of the purged grease.
  - b. For conditions including high temperatures, moisture, dirt or excessive vibration, consult the factory for a specific lubrication interval for your application.
  - c. Lubricant should be a high quality lithium complex grease conforming to NLGI Grade 2. Factory recommends Mobilux EP-2.
  - d. The use of synthetic lubricants will increase lubrication intervals by approximately 3 times.
6. Follow motor manufacturer's instructions for motor lubrication.
  7. For critical applications, a spare motor and belts should be available.

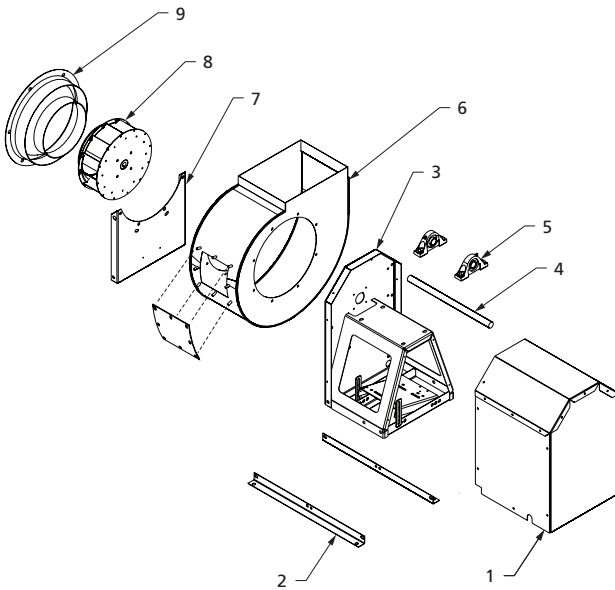
**REPAIR PARTS ILLUSTRATION FOR UTILITY EXHAUST BLOWERS**

**For Repair Parts, call 1-800-Grainger  
24 hours a day – 365 days a year**

*Please provide following information:*

- Model number
- Serial number (if any)
- Part description and number as shown in parts list

## REPAIR PARTS LIST FOR UTILITY EXHAUST BLOWERS

Ref. No.	Description	Part Number for Models:				Quantity
		20CK88	1WBW8	1WBW9	1WBX2	
1	Weatherhood	21DR24	21DR25	21DR26	21DR27	1
2	Base Angle	31TW80	21DP96	21DP97	21DP98	2
3	Drive Frame Assembly/Motor Plate	21DR01	21DR02	21DR03	21DR04	1
4	Shaft	31TW81	21DR22	21DT17	21DR23	1
5	Bearings	21DW56	21DT70	21DW58	21DW57	2
6	Scroll	31TW82	21DR18	21DR19	21DR20	1
7	Inlet Support Panel	21DR12	21DR13	21DR14	21DR15	1
8	Wheel	31TW83	21DR30	21DR31	21DR32	1
9	Inlet Cone and Ring	21DR07	21DR08	21DR09	21DR10	1
(*)	(†) Hardware Kit	21DR06	21DR06	21DR06	21DR06	1

Ref. No.	Description	Part Number for Models:				Quantity
		20CK87	5ZPJ8	5ZPJ9	5ZPK1	
1	Weatherhood	21DR24	21DR24	21DR24	21DR24	1
2	Base Angle	31TW80	31TW80	31TW80	31TW80	2
3	Drive Frame Assembly/Motor Plate	21DR01	21DR01	21DR01	21DR01	1
4	Shaft	21DT16	21DT16	21DT16	21DT16	1
5	Bearings	21DW56	21DW56	21DW56	21DW56	2
6	Scroll	31TW82	31TW82	31TW82	31TW82	1
7	Inlet Support Panel	21DR12	21DR12	21DR12	21DR12	1
8	Wheel	31TW84	31TW84	31TW84	31TW84	1
9	Inlet Cone and Ring	21DR07	21DR07	21DR07	21DR07	1
(*)	(†) Hardware Kit	21DR06	21DR06	21DR06	21DR06	1

(\*) Not Shown.

(†) Hardware Kit includes (4) 3/8-16 Spin-lock Nut, (4) 3/8-16 x 1-1/2 Spin-lock Bolt, (4) 3/8-16 x 1-1/2 Spin-lock Nut, and (4) 5/16-18 x 3/4 Spin-lock Bolt



## **DAYTON ONE-YEAR LIMITED WARRANTY**

**DAYTON ONE-YEAR LIMITED WARRANTY.** All Dayton® product models covered in this manual are warranted by Dayton Electric Mfg. Co. ("Dayton") to the original user against defects in workmanship or materials under normal use for one year after date of purchase. If the Dayton product is part of a set, only the portion that is defective is subject to this warranty. Any product or part which is determined to be defective in material or workmanship and returned to an authorized service location, as Dayton or Dayton's designee designates, shipping costs prepaid, will be, as the exclusive remedy, repaired or replaced with a new or reconditioned product or part of equal utility or a full refund given, at Dayton's or Dayton's designee's option, at no charge. For limited warranty claim procedures, see "Warranty Service" below. This warranty is void if there is evidence of misuse, mis-repair, mis-installation, abuse or alteration. This warranty does not cover normal wear and tear of Dayton products or portions of them, or products or portions of them which are consumable in normal use. This limited warranty gives purchasers specific legal rights, and you may also have other rights which vary from jurisdiction to jurisdiction.

### **WARRANTY DISCLAIMERS AND LIMITATIONS OF LIABILITY RELATING TO ALL CUSTOMERS FOR ALL PRODUCTS**

**LIMITATION OF LIABILITY.** TO THE EXTENT ALLOWABLE UNDER APPLICABLE LAW, DAYTON'S LIABILITY FOR CONSEQUENTIAL AND INCIDENTAL DAMAGES IS EXPRESSLY DISCLAIMED. DAYTON'S LIABILITY IN ALL EVENTS IS LIMITED TO AND SHALL NOT EXCEED THE PURCHASE PRICE PAID.

**WARRANTY DISCLAIMER.** A DILIGENT EFFORT HAS BEEN MADE TO PROVIDE PRODUCT INFORMATION AND ILLUSTRATE THE PRODUCTS IN THIS LITERATURE ACCURATELY; HOWEVER, SUCH INFORMATION AND ILLUSTRATIONS ARE FOR THE SOLE PURPOSE OF IDENTIFICATION, AND DO NOT EXPRESS OR IMPLY A WARRANTY THAT THE PRODUCTS ARE MERCHANTABLE, OR FIT FOR A PARTICULAR PURPOSE, OR THAT THE PRODUCTS WILL NECESSARILY CONFORM TO THE ILLUSTRATIONS OR DESCRIPTIONS. EXCEPT AS PROVIDED BELOW, NO WARRANTY OR AFFIRMATION OF FACT, EXPRESSED OR IMPLIED, OTHER THAN AS STATED IN THE "LIMITED WARRANTY" ABOVE IS MADE OR AUTHORIZED BY DAYTON.

**PRODUCT SUITABILITY.** MANY JURISDICTIONS HAVE CODES AND REGULATIONS GOVERNING SALES, CONSTRUCTION, INSTALLATION, AND/OR USE OF PRODUCTS FOR CERTAIN PURPOSES, WHICH MAY VARY FROM THOSE IN NEIGHBORING AREAS. WHILE ATTEMPTS ARE MADE TO ASSURE THAT DAYTON PRODUCTS COMPLY WITH SUCH CODES, DAYTON CANNOT GUARANTEE COMPLIANCE, AND CANNOT BE RESPONSIBLE FOR HOW THE PRODUCT IS INSTALLED OR USED. BEFORE PURCHASE AND USE OF A PRODUCT, REVIEW THE SAFETY/SPECIFICATIONS, AND ALL APPLICABLE NATIONAL AND LOCAL CODES AND REGULATIONS, AND BE SURE THAT THE PRODUCT, INSTALLATION, AND USE WILL COMPLY WITH THEM.

**CONSUMERS ONLY.** CERTAIN ASPECTS OF DISCLAIMERS ARE NOT APPLICABLE TO CONSUMER PRODUCTS SOLD TO CONSUMERS; (A) SOME JURISDICTIONS DO NOT ALLOW THE EXCLUSION OR LIMITATION OF INCIDENTAL OR CONSEQUENTIAL DAMAGES, SO THE ABOVE LIMITATION OR EXCLUSION MAY NOT APPLY TO YOU; (B) ALSO, SOME JURISDICTIONS DO NOT ALLOW A LIMITATION ON HOW LONG AN IMPLIED WARRANTY LASTS, SO THE ABOVE LIMITATION MAY NOT APPLY TO YOU; AND (C) BY LAW, DURING THE PERIOD OF THIS LIMITED WARRANTY, ANY IMPLIED WARRANTIES OF MERCHANTABILITY OR FITNESS FOR A PARTICULAR PURPOSE APPLICABLE TO CONSUMER PRODUCTS PURCHASED BY CONSUMERS, MAY NOT BE EXCLUDED OR OTHERWISE DISCLAIMED.

THIS LIMITED WARRANTY ONLY APPLIES TO UNITED STATES PURCHASERS FOR DELIVERY IN THE UNITED STATES.

### **WARRANTY SERVICE**

To obtain warranty service if you purchased the covered product directly from W.W. Grainger, Inc. ("Grainger"), (i) write or call or visit the local Grainger branch from which the product was purchased or another Grainger branch near you (see [www.grainger.com](http://www.grainger.com) for a listing of Grainger branches); or (ii) contact Grainger by going to [www.grainger.com](http://www.grainger.com) and clicking on the "Contact Us" link at the top of the page, then clicking on the "Email us" link; or (iii) call Customer Care (toll free) at 1-888-361-8649. To obtain warranty service if you purchased the covered product from another distributor or retailer, (i) go to [www.grainger.com](http://www.grainger.com) for Warranty Service; (ii) write or call or visit a Grainger branch near you; or (iii) call Customer Care (toll free) at 1-888-361-8649. In any case, you will need to provide, to the extent available, the purchase date, the original invoice number, the stock number, a description of the defect, and anything else specified in this Dayton One-Year Limited Warranty. You may be required to send the product in for inspection at your cost. You can follow up on the progress of inspections and corrections in the same ways. Title and risk of loss pass to buyer on delivery to common carrier, so if product was damaged in transit to you, file claim with carrier, not retailer, Grainger or Dayton. For warranty information for purchasers and/or delivery outside the United States, please use the following applicable contact information:

**Dayton Electric Mfg. Co.,  
100 Grainger Parkway, Lake Forest, IL 60045 U.S.A.  
or call +1-888-361-8649**