

Tag: _____ **Engineer:** _____
Project: _____ **Contractor:** _____
Location: _____ **Architect:** _____
Date: _____ **Submitted By:** _____



MODEL XAL-6 Extruded Stationary Louver

Non-Drainable Blade, AMCA Licensed

Standard Construction

FRAME: 6" (152) x .081 (2.1) extruded aluminum, 6063-T6

BLADES: .081 (2.1) extruded aluminum, 6063-T6
Non-Drainable Blades fixed at 37.5° angle,
Spaced approximately 4-3/4" (121)

SCREEN: Bird screen - 3/4" (19) x .050" (1.3) expanded,
flattened aluminum with a removable frame on the
interior of the louver. Screen adds approximately
1/2" (12.7) to depth of louver.

FINISH: Mill

MINIMUM SIZE: 6"w (152) x 12"h (305)
MAXIMUM

ASSEMBLY SIZE: Single Sections will not exceed 120"w (3048) x
90"h (2286) or 90"w (2286) x 120"h (3048). Larger
sizes will require field assembly of smaller sections.

DESIGN LOAD: 20 psf (97.6 kg/m²) Consult for higher pressures.

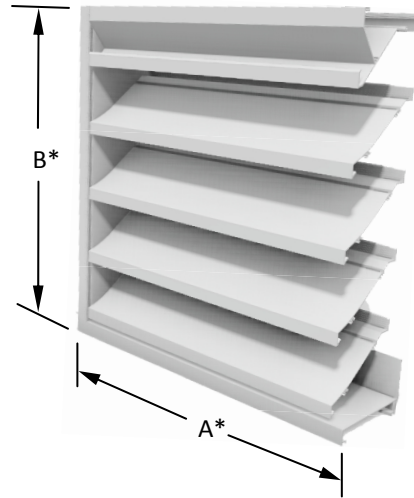

All dimensions shown in inches, parenthesis () indicate millimeters.

LEED Material Information

VOC Content (g/L) - 0

Manufacturing Location (MR 5.1)

- Marion, NC 28752

Recycled Content (MR 4.1 & 4.2)

- 10% Post-Consumer
- 80% Pre-Consumer

* Width [A dimension] and Height [B dimension] are approximately 1/4" (6) under listed size, unless otherwise specified.

Optional Construction

- .125" (3.2) extruded aluminum frame
- Sill Extension
- Flange Frame [1 1/2" (38)]
- Sub-Frame
- Hinged Sub-Frame
- Welded Construction
- Filter Racks
- Security Bars:
 - Front
 - Rear
- Optional Bird and Insect Screens
- Optional Finishes: Consult Finishes Chart
- Blank Off Panel:
 - Aluminum, Non-Insulated
 - Aluminum, Insulated
- Optional Shapes: Consult Special Shapes

Frame Options

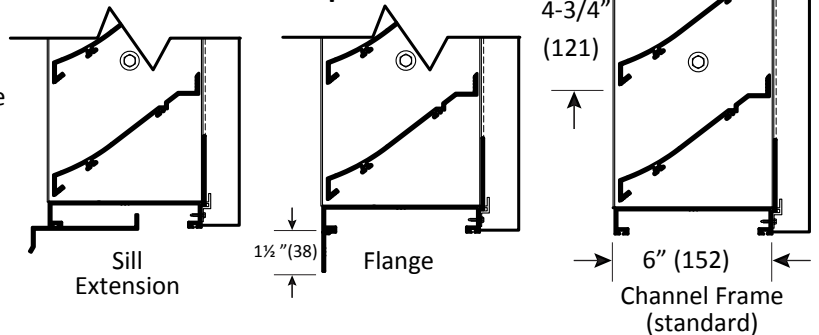

Note: Blade supports may be added as necessary. Blade supports will increase overall depth of louver; exact amount is dependent upon louver size, assembly configuration or windload requirements.

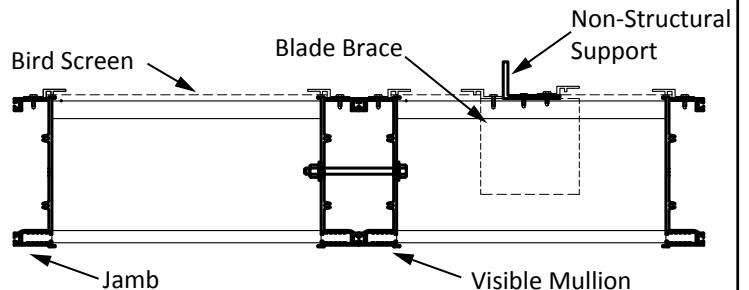

Consult NCA for Other Special Requirements

All Stated Specifications Are Subject to Change Without notice or Obligation.

XAL-6 - 0613 / Replaces XAL-6-0905



PERFORMANCE DATA

FREE AREA GUIDE FOR XAL-6 (Free area in ft² and m²)

		Width in Inches (Meters)																		
		12	18	24	30	36	42	48	54	60	66	72	78	84	90	96	102	108	114	120
Height in Inches (Meters)	12	0.22	0.35	0.48	0.61	0.74	0.87	1.00	1.14	1.27	1.40	1.53	1.66	1.79	1.93	2.06	2.19	2.32	2.45	2.58
	18	0.51	0.82	1.12	1.43	1.74	2.05	2.36	2.67	2.98	3.29	3.60	3.91	4.22	4.53	4.83	5.14	5.45	5.76	6.07
	24	0.87	1.40	1.94	2.47	3.00	3.54	4.07	4.60	5.13	5.67	6.20	6.73	7.26	7.80	8.33	8.86	9.40	9.93	10.46
	30	1.16	1.87	2.58	3.29	4.00	4.71	5.43	6.14	6.85	7.56	8.27	8.98	9.69	10.40	11.11	11.82	12.53	13.24	13.95
	36	1.45	2.34	3.23	4.12	5.01	5.89	6.78	7.67	8.56	9.45	10.33	11.22	12.11	13.00	13.89	14.77	15.66	16.55	17.44
	42	1.74	2.81	3.88	4.94	6.01	7.07	8.14	9.20	10.27	11.34	12.40	13.47	14.53	15.60	16.66	17.73	18.80	19.86	20.93
	48	2.11	3.40	4.69	5.98	7.27	8.56	9.85	11.14	12.42	13.71	15.00	16.29	17.58	18.87	20.16	21.45	22.74	24.03	25.32
	54	2.40	3.87	5.33	6.80	8.27	9.74	11.20	12.67	14.14	15.60	17.07	18.54	20.00	21.47	22.94	24.40	25.87	27.34	28.81
	60	2.69	4.34	5.98	7.63	9.27	10.91	12.56	14.20	15.85	17.49	19.14	20.78	22.43	24.07	25.72	27.36	29.01	30.65	32.29
	66	3.06	4.93	6.79	8.66	10.53	12.40	14.27	16.13	18.00	19.87	21.74	23.61	25.48	27.34	29.21	31.08	32.95	34.82	36.68
	72	3.35	5.39	7.44	9.49	11.53	13.58	15.62	17.67	19.71	21.76	23.81	25.85	27.90	29.94	31.99	34.04	36.08	38.13	40.17
	78	3.64	5.86	8.09	10.31	12.53	14.76	16.98	19.20	21.43	23.65	25.87	28.10	30.32	32.54	34.77	36.99	39.21	41.44	43.66
	84	3.93	6.33	8.73	11.13	13.53	15.94	18.34	20.74	23.14	25.54	27.94	30.34	32.74	35.14	37.55	39.95	42.35	44.75	47.15
	90	4.30	6.92	9.55	12.17	14.79	17.42	20.04	22.67	25.29	27.92	30.54	33.17	35.79	38.42	41.04	43.67	46.29	48.92	51.54
	96	4.59	7.39	10.19	12.99	15.80	18.60	21.40	24.20	27.01	29.81	32.61	35.41	38.21	41.02	43.82	46.62	49.42	52.23	55.03
		120	0.30	0.46	0.61	0.76	0.91	1.07	1.22	1.37	1.52	1.68	1.83	1.98	2.13	2.29	2.44	2.59	2.74	2.90

PRESSURE DROP

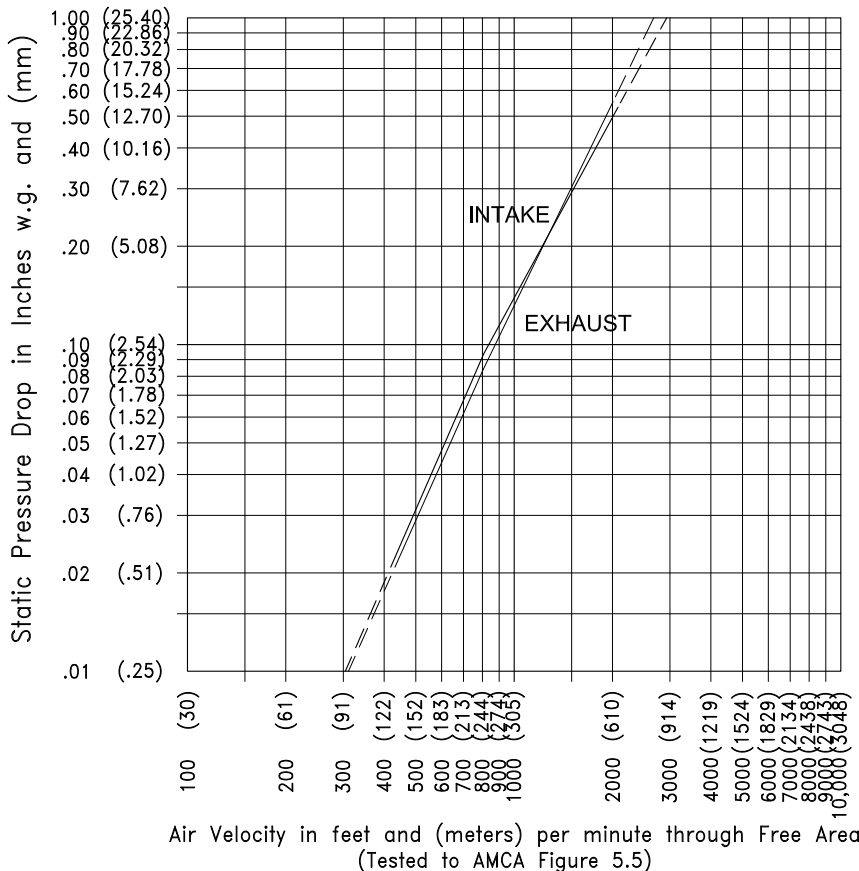

NCA Manufacturing Inc. certifies that the Model XAL-6 louver shown herein is certified to bear the AMCA seal. The ratings shown are based on tests and procedures performed in accordance with AMCA Publication 511 and comply with the requirements of the AMCA Certified Ratings Program.

The AMCA Certified Ratings Seal applies to air performance ratings and water penetration ratings only.

Beginning Point of Water Penetration at .01oz./ft² is **911 FPM (244 m/min)** Free Area Velocity.

Notes:

- Pressure Drop and Water Penetration Data applies to test unit size 48" w x 48" h (1219 x 1219) only.
- Performance data does not include the effects of bird screen.
- All Performance shown is at standard air density of 0.075 lb/ft³ (1.2 kg/m³).
- Water Penetration data is for 15 minute test duration