

MODEL D-HFA-4

HIGH PERFORMANCE 4" FIXED LOUVER

STANDARD CONSTRUCTION:

Frame: .081 Extruded Aluminum, 4.21" Deep

Blade: .060 Extruded Aluminum positioned on a 50° angle on approximately 3.75" centers

Birdscreen: 0.75" x .051" Flattened Aluminum in removable frame. Screen is mounted as standard on inside (rear) as looking from exterior of building.

Finish: Mill Aluminum (Std.)

Minimum Size: 12 x12

Maximum Single Section: 120"w x 84"h or 84"w x 120"h

Note: 10' max width

OPTIONS:

- Flanged Frame (1.50" std.), (1" std for shapes R_)
- Custom Flange (1", 2" , or 3"), (1.5", 2", or 3" for shapes R_)
- Glazing Adapter (0.50" or 0.75")
- Extended Sill
- 0.125" Blades
- Insect Screen (Other Screens Available, See Screen Page)
- Filter Racks (no screen)
- Security Bars
- Hinged Sub Frame
- Welded Construction (Wind Load +/- 50 psf)
- Blank-off, Alum., non-insulated, no screen, non-removeable
- Blank-off, Alum., non-insulated, with bird screen or insect screen
- Blank-off, Alum., insulated double wall, with bird screen, removable
- Blank-off, Alum., insulated double wall, no screen, non-removeable

AVAILABLE FINISHES:

- Powder Polyester TGIC** (2 coats) baked on at 410°F, 2.5 to 3.5 mils Meets AAMA-2603 Standards
- Powder Super durable polyester** (2 coats) baked on at 410°F, 2.5 to 3.5 mils Meets AAMA-2604-05 Standards
- Acrylic baked enamel** (ACRA-BOND® ULTRA) by AkzoNobel baked on at 350°F, 0.8 to 1.2 mils dry Meets AAMA-2603 Standards
- Kynar 500®** or HYLAR® 5000 70% TRINAR® (2 coats) by AkzoNobel baked on at 450°F, 1.2 to 1.6 mils dry, Meets AAMA-2605-05 Standards
- Kynar 500®** or HYLAR® 5000 (70% Tri-Escent II) (2 coats) by AkzoNobel, a superior finish to other metallic or anodized finishes. A blend of mica, ceramic, and inorganic pigments creates subtle yet dazzling design that goes beyond metallic color without the requirement of a clear coat. 14 standard colors - custom colors available. Baked on at 415°F, 1.4 to 1.8 mils dry, meets AAMA 2605-05.
- Clear Anodize** 204 R-1 Class II (AA-C22A31)(0.4 to 0.7 mil)
- Clear Anodize** 215 R-1 Class I (AA-C22A41)(>0.7 mil)
- Integral Color Anodize** (AA-C22A42)(>0.7 mil)
 - Clear coat available for all above finishes.
 - Hylar® 5000 is a registered trademark of Solvay Solexis, Inc.
 - Kynar® 500 is a registered trademark of Arkema.
 - TRINAR® is a registered trademarks of AkzoNobel
 - ACRA-BOND® ULTRA is a registered trademark of AkzoNobel

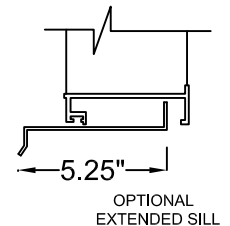
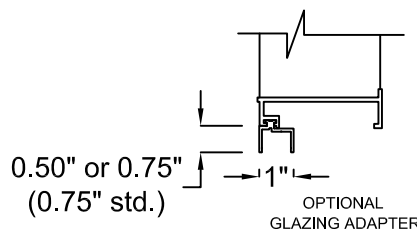
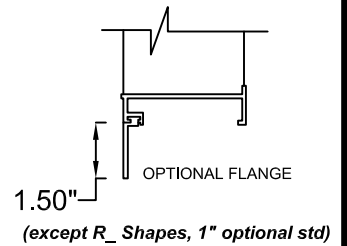
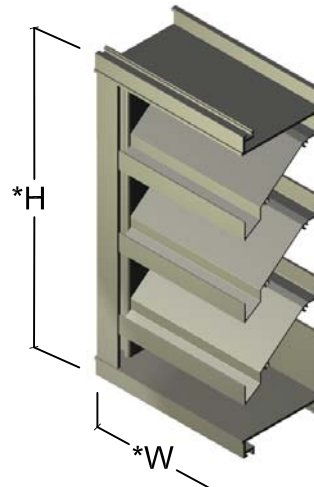
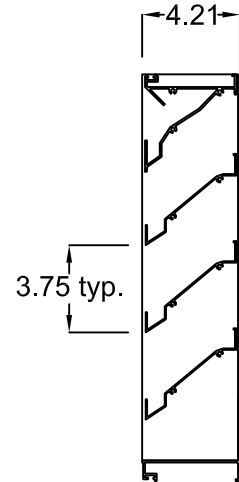

*Width and Height dimensions are approximately 1/4" under listed size.

Due to continuing research, United Enertech reserves the right to change specifications without notice.



3005 South Hickory Street
Chattanooga, Tennessee 37407
Tel: (423) 698-7715
Fax: (423) 698-6629
www.unitedenertech.com

MODEL D-HFA-4 (Drainable Blade w/ Jamb Gutters and Downspouts)

DRAWN BY: CLJ	DATE: June 2019	REV. DATE:	REV. NO.:	DWG. NO.: A-3b
------------------	--------------------	------------	-----------	--------------------------

SUGGESTED SPECIFICATION

Furnish and install louvers as hereinafter specified where shown on plans or as described in schedules. Louvers shall be stationary drainable type with drain gutters in each blade and downspouts in jambs and mullions. Stationary drainable blades shall be contained within a 4.13" frame. Louver components (heads, jambs, sills, blades, and mullions) shall be factory assembled by the louver manufacturer. Louver sizes too large for shipping shall be built up by the contractor from factory assembled louver sections to provide overall sizes required. Louver design shall incorporate structural supports required to withstand a wind load of 30 lbs. Per sq. ft. (equivalent of a 110 mph wind), United Enertech Model D-HFA-4.



United Enertech certifies that the D-HFA-4 shown herein is licensed to bear the AMCA Seal. The ratings shown are based on tests and procedures performed in accordance with AMCA Publication 511 and comply with the requirements of the AMCA Certified Ratings Program. The AMCA certified rating seal applies to air performance ratings and water penetration ratings.

*50 PSF Rating available.

PERFORMANCE DATA

Beginning point of WATER PENETRATION

is

901 fpm

free area velocity at .01 oz. of water penetration

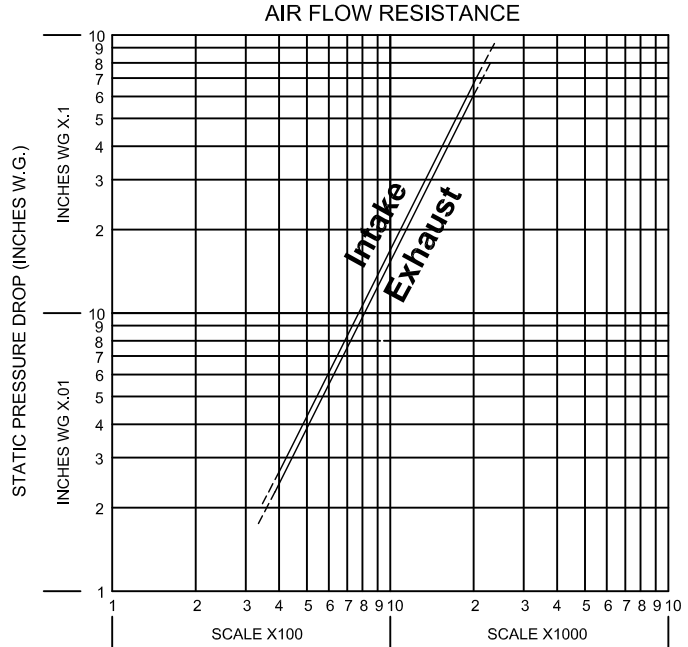
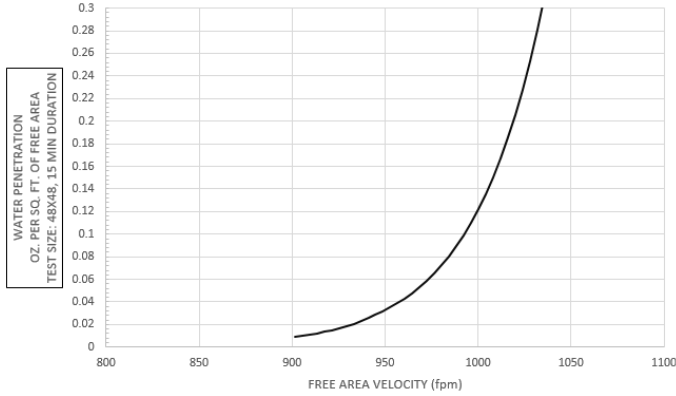

Based on STANDARD AIR- .075 lb. per cubic foot.

Ratings do not include the effects of screen.

Device Setup Fig. 5.5

Test size 48" x 48"

Louver Height Inches	D-HFA-4 FREE AREA IN SQ. FT.																			Louver Height Inches
	Width - Inches																			
	12	18	24	30	36	42	48	54	60	66	72	78	84	90	96	102	108	114	120	
12	0.34	0.55	0.75	0.96	1.17	1.38	1.59	1.79	2.00	2.21	2.42	2.62	2.83	3.04	3.25	3.46	3.66	3.87	4.08	12
18	0.61	0.98	1.35	1.72	2.10	2.47	2.84	3.21	3.59	3.96	4.33	4.70	5.08	5.45	5.82	6.19	6.57	6.94	7.31	18
24	0.83	1.35	1.86	2.37	2.88	3.40	3.91	4.42	4.93	5.45	5.96	6.47	6.98	7.50	8.01	8.52	9.03	9.55	10.06	24
30	1.15	1.86	2.56	3.27	3.98	4.69	5.39	6.10	6.81	7.52	8.22	8.93	9.64	10.35	11.05	11.76	12.47	13.18	13.88	30
36	1.38	2.22	3.07	3.92	4.77	5.61	6.46	7.31	8.16	9.00	9.85	10.70	11.55	12.39	13.24	14.09	14.94	15.78	16.63	36
42	1.62	2.61	3.60	4.60	5.59	6.59	7.58	8.57	9.57	10.56	11.56	12.55	13.55	14.54	15.53	16.53	17.52	18.52	19.51	42
48	1.92	3.10	4.28	5.46	6.64	7.82	9.00	10.18	11.37	12.55	13.73	14.91	16.09	17.27	18.45	19.63	20.81	21.99	23.17	48
54	2.15	3.47	4.79	6.12	7.44	8.76	10.08	11.41	12.73	14.05	15.37	16.70	18.02	19.34	20.66	21.99	23.31	24.63	25.95	54
60	2.47	3.98	5.50	7.02	8.54	10.05	11.57	13.09	14.61	16.12	17.64	19.16	20.68	22.19	23.71	25.23	26.75	28.26	29.78	60
66	2.69	4.35	6.01	7.67	9.32	10.98	12.64	14.30	15.95	17.61	19.27	20.93	22.58	24.24	25.90	27.56	29.21	30.87	32.53	66
72	2.93	4.74	6.54	8.34	10.15	11.95	13.76	15.56	17.37	19.17	20.97	22.78	24.58	26.39	28.19	29.99	31.80	33.60	35.41	72
78	3.24	5.23	7.22	9.22	11.21	13.20	15.19	17.19	19.18	21.17	23.16	25.16	27.15	29.14	31.13	33.13	35.12	37.11	39.10	78
84	3.47	5.60	7.73	9.86	12.00	14.13	16.26	18.39	20.53	22.66	24.79	26.92	29.06	31.19	33.32	35.45	37.59	39.72	41.85	84
90	3.78	6.11	8.44	10.76	13.09	15.42	17.75	20.07	22.40	24.73	27.06	29.38	31.71							90
96	4.01	6.48	8.94	11.41	13.88	16.35	18.81	21.28	23.75	26.22	28.68	31.15	33.62							96
102	4.25	6.86	9.48	12.09	14.70	17.32	19.93	22.55	25.16	27.78	30.39	33.00	35.62							102
108	4.55	7.36	10.16	12.96	15.76	18.57	21.37	24.17	26.97	29.78	32.58	35.38	38.18							108
114	4.78	7.72	10.67	13.61	16.55	19.49	22.44	25.38	28.32	31.26	34.21	37.15	40.09							114
120	5.10	8.24	11.37	14.51	17.65	20.79	23.92	27.06	30.20	33.34	36.47	39.61	42.75							120