

## Miami-Dade Approved Wind-Driven Rain Louver

### Application and Design

EHV-550D is a High Velocity Wind Driven Rain louver designed to protect intake and exhaust openings in building exterior walls. EHV-550D is tested in accordance with AMCA 500-L Air Performance, Water Penetration and Wind Driven Rain. EHV-550D is tested in accordance with AMCA 540 Test Method for Louvers Impacted by Wind Borne Debris (Basic Protection - Missile Level D, and Enhanced Protection - Missile Level E). EHV-550D is tested in accordance with AMCA 550 Test Method for High Velocity Wind Driven Rain Resistant Louvers. **EHV-550D is licensed to bear the AMCA seal allowing design professionals to select and apply with confidence.** EHV-550D is tested and qualified per the following Florida test protocols: TAS 201 (Large Missile Impact, Enhanced Protection - Missile Level E), TAS 202 (Uniform Static Air Pressure) and TAS 203 (Cyclic Wind Loading). Per Miami-Dade D.R.E.R, the EHV-550D may be installed in locations where the room behind the louver is NOT designed to drain water penetrating into the room or the room will house non-water resistant or water proof equipment, components or supplies.

### Standard Construction

- Frame** . . . . . Heavy gauge extruded 6005-T5 aluminum (jamb), heavy gauge extruded 6005-T5 aluminum (head & sill), 5.5 in. x 0.081 in. nominal wall thickness
- Blades (Front)** . . . J style, heavy gauge extruded 6005-T5 aluminum, 0.081 in. nominal wall thickness, positioned on approximately 1.9 in. blade spacing
- Blades (Rear)** . . . Vertical rain resistant style, heavy gauge extruded 6005-T5 aluminum, 0.050 in. nominal wall thickness, positioned on approximately 0.88 in. blade spacing
- Construction** . . . Mechanically fastened
- Birdscreen** . . . . . 3/4 in. x 0.051 in. flattened expanded aluminum in removable frame, inside mount (rear)
- Finish** . . . . . Mill
- Minimum Size** . . . 12 in. W x 12 in. H
- Maximum Single Section Size** . . . 60 in. W x 96 in. H

### Options (at additional cost)

- A variety of bird and insect screens
- Blank-off panel
- Extended sill
- Filter rack
- Flanged frame
- Security bars
- A variety of architectural finishes including:
  - Clear anodize
  - Integral color anodize
  - Baked enamel
  - Kynar

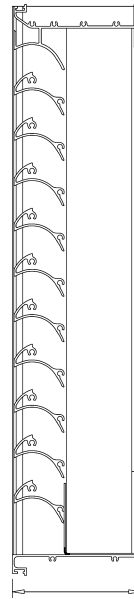

5.5" [140mm] NOM.



This label does not signify AMCA airflow performance certification.

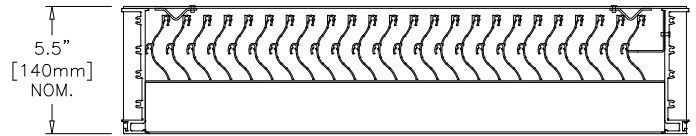

5.5" [140mm] NOM.

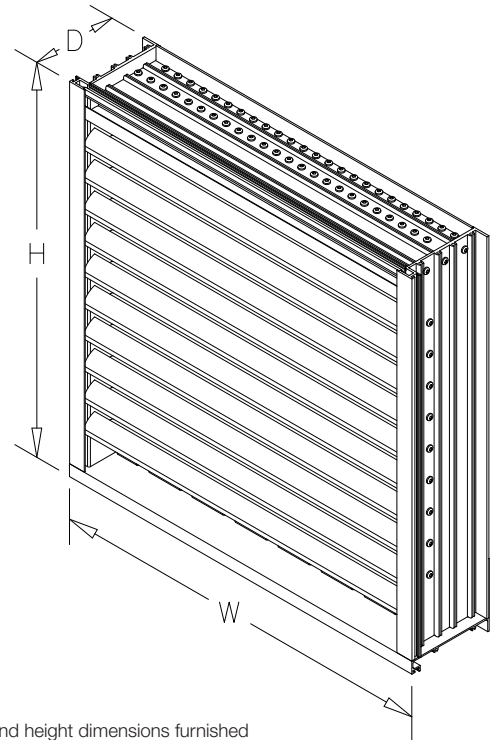

\*Width and height dimensions furnished approximately 0.50 inch under size.

# PERFORMANCE DATA

# EHV-550D

Florida Product Approval No.: FL30297  
 Miami-Dade, FL NOA No.: 19-0430.03 EXP. 08/15/2024  
 AMCA 540 and 550 Listed  
 Maximum Wind-load: 100 PSF

## Wind-Driven Rain Performance

Ventilation Air Core Velocity m/s (fpm)	Free Area Velocity m/s (fpm)	75mm/h (3 in/hr) Rainfall & 13 m/s (29 mph) Wind Velocity		200mm/h (8 in/hr) Rainfall & 22 m/s (50 mph) Wind Velocity		Water Penetration Effectiveness %	Water Penetration Classification
		Water Penetration Effectiveness %	Water Penetration Classification	Ventilation Air Core Velocity m/s (fpm)	Free Area Velocity m/s (fpm)		
0.0 (0)	0.0 (0)		A	0.0 (0)	0.0 (0)		A
0.5 (98)	0.9 (177)		A	0.5 (98)	0.9 (177)		A
1.0 (197)	1.8 (356)		A	1.0 (197)	1.8 (356)		A
1.5 (295)	2.7 (533)		A	1.5 (295)	2.7 (533)		A
2.0 (394)	3.6 (712)		A	2.0 (394)	3.6 (712)		A
2.5 (492)	4.5 (889)		A	2.5 (492)	4.5 (889)		A
3.0 (591)	5.4 (1068)		A	3.0 (591)	5.4 (1068)		A
3.5 (689)	6.3 (1245)		A	3.5 (689)	6.3 (1245)		A
4.0 (787)	7.2 (1422)		A	4.0 (782)	7.2 (1413)	99.7	A
4.5 (886)	8.1 (1600)		A	4.5 (883)	8.1 (1595)	99.6	A
5.0 (980)	9.0 (1770)	100.0	A	5.0 (980)	9.0 (1770)	99.5	A

Discharge Loss Coefficient Class (Intake) = 3

Weather louvers shall be classified by their ability to reject simulated rain. The table shows different classifications based on the maximum simulated rain penetration per square meter (square feet) of louver. Water penetration rating at a given louver face velocity is determined by the water penetration while the louver is subjected to a selected simulated rainfall rate and wind velocity.



Greenheck Fan Corporation certifies that the EHV-550D louvers shown herein are licensed to bear the AMCA Seal. The ratings shown are based on tests and procedures performed in accordance with AMCA Publication 511 and comply with the requirements of the AMCA Certified Ratings Program. The AMCA Certified Ratings Seal applies to air performance, water penetration, and wind-driven rain ratings.



HIGH VELOCITY RAIN RESISTANT WITH BLADES  
 FULLY OPEN AND IMPACT RESISTANT LOUVER  
 Enhanced Protection Level E  
See www.AMCA.org for all certified or listed products

This label does not signify AMCA airflow performance certification.

Greenheck Fan Corporation certifies that the EHV-550D louvers shown herein are approved to bear the AMCA Listing Label. The Ratings shown are based on tests and procedures performed in accordance with AMCA Publications and comply with the requirements of the AMCA Listing Label Program. The AMCA Listing Label applies to Wind Borne Debris Impact Resistant and High Velocity Wind-Driven Rain Resistant Louvers.

Discharge Loss Coefficient Classifications	
Class	Discharge Loss Coefficient
1	0.4 and Above
2	0.3 to 0.399
3	0.2 to 0.299
4	0.199 and Below

Wind-driven Rain Penetration Classes	
Class	Effectiveness
A	1 to 0.99
B	0.989 to 0.95
C	0.949 to 0.80
D	Below 0.80

## Airflow Resistance (Standard Air - .075 lb/ft<sup>3</sup>)

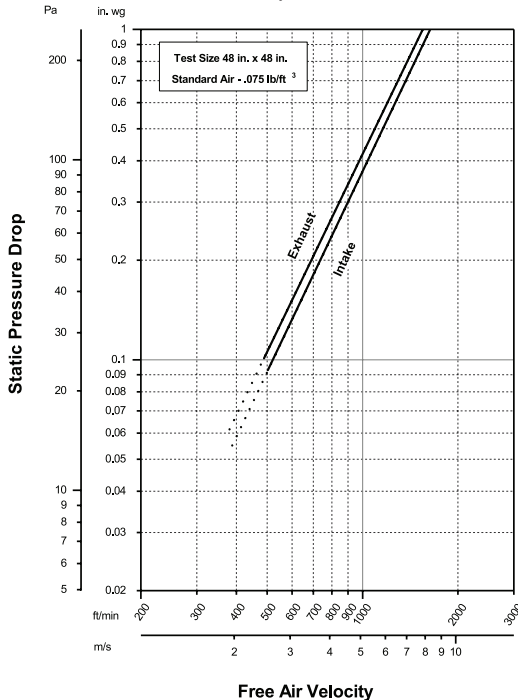

Model EHV-550D resistance to airflow (pressure drop) varies depending on louver application (air intake or air exhaust). Free area velocities (shown) are higher than average velocity through the overall louver size. See louver selection information. (Test Figure 5.5-6.5)

## Water Penetration

Test Size 48 in. x 48 in. Test Duration of 15 min

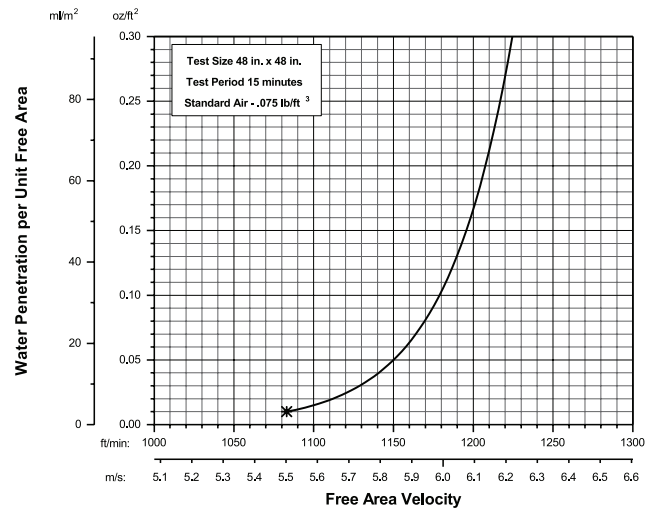

The AMCA Water Penetration Test provides a method for comparing various louver models and designs as to their efficiency in resisting the penetration of rainfall under specific laboratory test conditions. The beginning point of water penetration is defined as that velocity where the water penetration curve projects through 0.01 oz. of water (penetration) per sq. ft. of louver free area. **\*The beginning point of water penetration for Model EHV-550D is 1083 fpm free area velocity.** These performance ratings do not guarantee a louver to be weather-proof or stormproof and should be used in combination with other factors including good engineering judgement in selecting louvers.



# PERFORMANCE DATA

# EHV-550D

Florida Product Approval No.: FL30297  
 Miami-Dade, FL NOA No.: 19-0430.03 EXP. 08/15/2024  
 AMCA 540 and 550 Listed  
 Maximum Wind-load: 100 PSF

## Free Area Chart (sq. ft.)

Louver Height Inches	Louver Width in Inches								
	12	18	24	30	36	42	<b>48</b>	54	60
12	0.23	0.38	0.52	0.66	0.81	0.95	1.09	1.24	1.38
18	0.47	0.75	1.04	1.33	1.61	1.90	2.19	2.47	2.76
24	0.72	1.16	1.60	2.04	2.48	2.92	3.36	3.80	4.24
30	0.97	1.56	2.16	2.75	3.35	3.94	4.54	5.13	5.73
36	1.22	1.97	2.72	3.47	4.22	4.97	5.72	6.47	7.22
42	1.47	2.38	3.28	4.19	5.10	6.00	6.91	7.81	8.72
<b>48</b>	1.71	2.76	3.81	4.86	5.92	6.97	<b>8.02</b>	9.07	10.12
54	1.94	3.14	4.33	5.53	6.72	7.92	9.11	10.31	11.50
60	2.18	3.52	4.86	6.20	7.54	8.88	10.22	11.56	12.90
66	2.43	3.93	5.42	6.92	8.41	9.91	11.40	12.90	14.39
72	2.68	4.33	5.98	7.63	9.29	10.94	12.59	14.24	15.89
78	2.93	4.74	6.55	8.35	10.16	11.97	13.77	15.58	17.38
84	3.19	5.15	7.11	9.07	11.03	12.99	14.95	16.91	18.87
90	3.42	5.52	7.63	9.73	11.83	13.94	16.04	18.14	20.25
96	3.65	5.90	8.14	10.39	12.64	14.89	17.13	19.38	21.63

## Core Area Chart (sq. ft.)

Louver Height Inches	Louver Width in Inches								
	12	18	24	30	36	42	<b>48</b>	54	60
12	0.62	1.01	1.39	1.78	2.16	2.55	2.93	3.32	3.70
18	1.03	1.67	2.30	2.93	3.57	4.20	4.84	5.47	6.11
24	1.44	2.32	3.21	4.09	4.97	5.86	6.74	7.63	8.51
30	1.84	2.98	4.11	5.25	6.38	7.52	8.65	9.78	10.92
36	2.25	3.63	5.02	6.40	7.79	9.17	10.56	11.94	13.32
42	2.66	4.29	5.92	7.56	9.19	10.83	12.46	14.10	15.73
<b>48</b>	3.06	4.95	6.83	8.72	10.60	12.48	<b>14.37</b>	16.25	18.14
54	3.47	5.60	7.74	9.87	12.01	14.14	16.27	18.41	20.54
60	3.87	6.26	8.64	11.03	13.41	15.80	18.18	20.57	22.95
66	4.28	6.92	9.55	12.18	14.82	17.45	20.09	22.72	25.36
72	4.69	7.57	10.46	13.34	16.22	19.11	21.99	24.88	27.76
78	5.09	8.23	11.36	14.50	17.63	20.77	23.90	27.03	30.17
84	5.50	8.88	12.27	15.65	19.04	22.42	25.81	29.19	32.57
90	5.91	9.54	13.17	16.81	20.44	24.08	27.71	31.35	34.98
96	6.31	10.20	14.08	17.97	21.85	25.73	29.62	33.50	37.39

# INSTALLATION DETAILS

# EHV-550D

Florida Product Approval No.: FL30297

Miami-Dade, FL NOA No.: 19-0430.03 EXP. 08/15/2024

AMCA 540 and 550 Listed

Maximum Wind-load: 100 PSF

## Maximum Size and Installation Information

Model EHV-550D is a Miami-Dade Approved and Florida Product Approved louver and must be installed in accordance with the installation instructions shown in the Miami-Dade NOA. Model EHV-550D is qualified for installation within concrete/masonry, steel, aluminum and wood substrate. Model EHV-550D is tested and qualified to withstand positive and negative wind pressure loads up to 100 PSF. The maximum single section width is 60 inches. The maximum single section height is 96 inches. Multi-wide assemblies are permitted without any additional reinforcing. Multi-high assemblies are permitted provided suitable load bearing structure is provided (by others) at each louver section(s) head and sill condition so the louver section(s) may be installed in accordance with the Miami-Dade NOA. Structural reinforcing members along with any associated installation hardware or anchors is not provided by Greenheck unless indicated otherwise by Greenheck. Options and are not subject to structural analysis unless indicated otherwise by Greenheck.

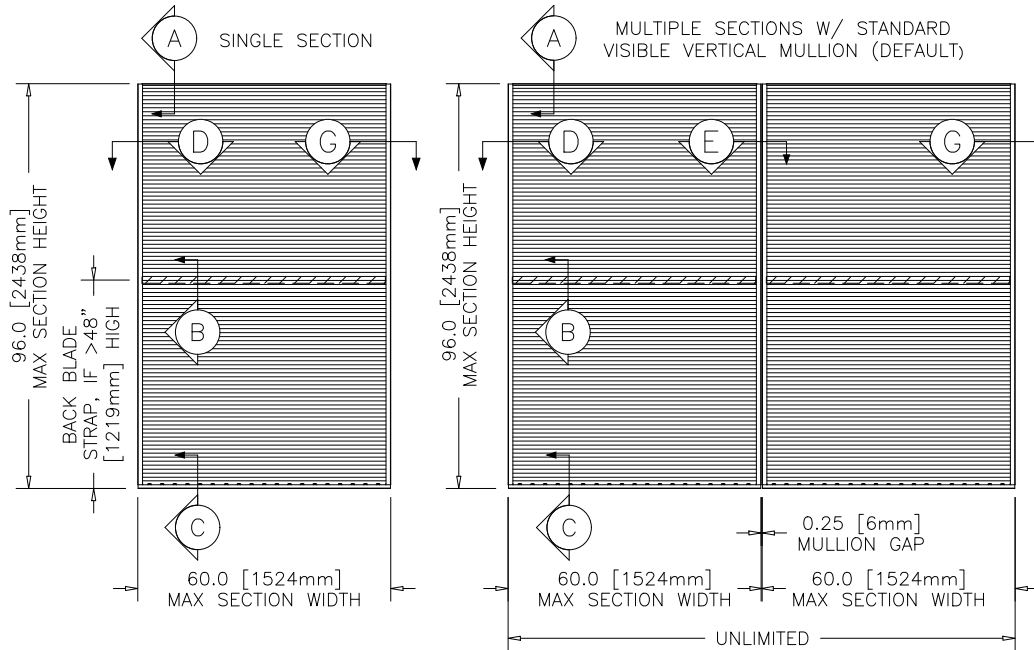

### Minimum Single Section Size

12 in. W x 12 in. H

### Maximum Single Section Size

60 in. W x 96 in. H

# PRODUCT DETAILS

# EHV-550D

Florida Product Approval No.: FL30297  
 Miami-Dade, FL NOA No.: 19-0430.03 EXP. 08/15/2024  
 AMCA 540 and 550 Listed  
 Maximum Wind-load: 100 PSF

NOTE: SEALANT, BACKER ROD, NON-COMPRESSIBLE DEAD-LOAD SHIMS, SEPARATION OF DISSIMILAR MATERIALS AND SUBSTRATE ARE NOT BY LOUVER MANUFACTURER (TYPICAL ALL DETAILS). SHIM AS NEEDED, PERIMETER SEALANT REQUIRED TO PASS ANSI/AMCA 550 HIGH VELOCITY WIND DRIVEN RAIN.

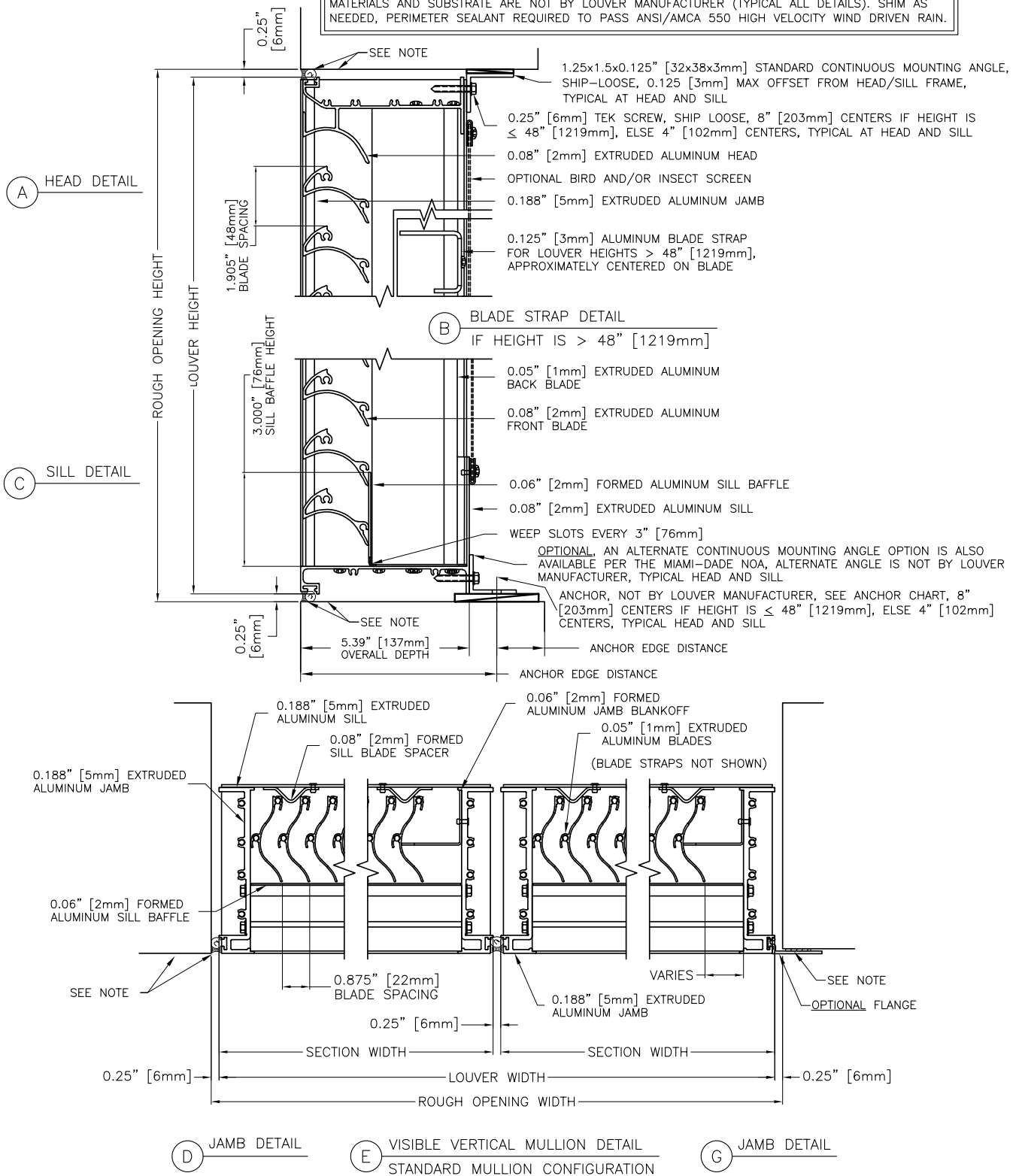

## OPTIONAL INVERTED CONTINUOUS MOUNTING ANGLE: SETUPS, CAUTIONS, & NOTES

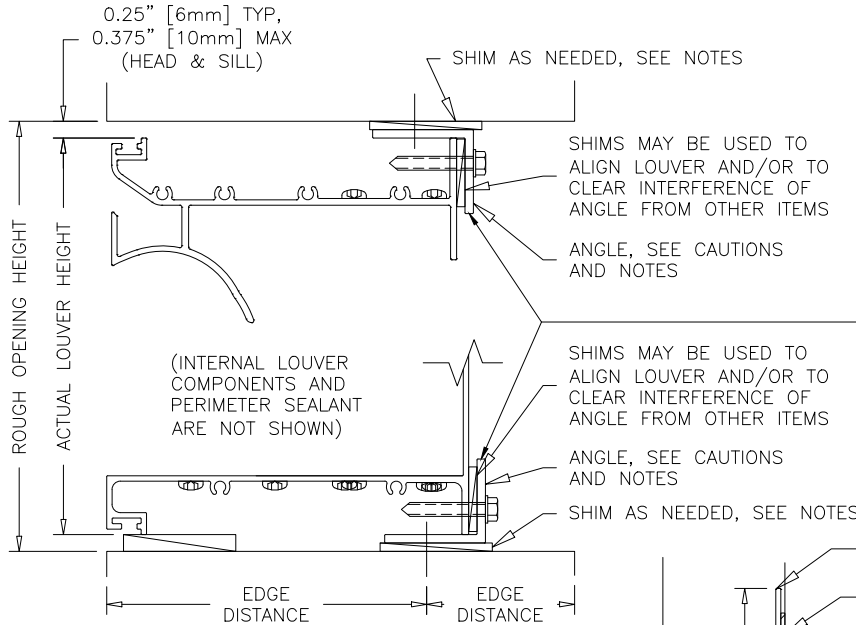

NOTES: INVERTED ANGLE OPTION SHOWN UTILIZING THE THE MANUFACTURER PROVIDED STANDARD CONTINUOUS MOUNTING ANGEL AT THE HEAD/SILL. THE STANDARD ANGEL SHALL NOT EXTEND MORE THAN 0.125" [3mm] PAST THE TOP OF THE HEAD/SILL.

THE STANDARD CONTINUOUS MOUNTING ANGLE CANNOT BE USED IN THE INVERTED POSITION AT BOTH THE HEAD AND SILL LOCATIONS. SEE CAUTION NOTES.

AN ALTERNATE CONTINUOUS MOUNTING ANGLE MAY BE USED FOR OTHER NEEDED SETUPS. AN ALTERNATE ANGLE CAN EXTEND MORE THAN 0.125" [3mm] PAST THE TOP OF THE HEAD/SILL. REFER TO THE LOUVER'S MIAMI-DADE NOA "ALTERNATE CONTINUOUS MOUNTING ANGLE ALLOWABLE SETUPS" TABLE FOR ALLOWABLE DESIGNS OF THE ALTERNATE ANGLE.

**CAUTION!** THE MANUFACTURER PROVIDED STANDARD CONTINUOUS MOUNTING ANGLES CAN ONLY BE USED IN THE INVERTED POSITION IF ONLY ONE OF THE STANDARD ANGLES IS INVERTED. EITHER AT THE HEAD OR AT THE SILL, NOT BOTH.

**WHY:** DUE TO REQUIRED OFFSETS, USE OF THE FACTORY PUNCHED HOLES IN THE STANDARD CONTINUOUS MOUNTING ANGLE WILL POSITION THE HORIZONTAL LEG OF THE STANDARD ANGLE UP AGAINST THE HEAD/ SILL FRAME MEMBER (AS SHOWN ON THIS PAGE). THEREFORE, IT IS IMPOSSIBLE TO PRE-MOUNT BOTH STANDARD ANGLES TO THE SUBSTRATE IN THE INVERTED POSITION AND STILL HAVE CLEARANCE FOR THE LOUVER HEAD AND/OR SILL FRAME TO SLIDE OVER AND PAST THE ANCHOR HEADS ON THE INVERTED ANGLES.

**SOLUTION:** TO OVERCOME THE ABOVE ISSUE, AN ALTERNATE CONTINUOUS MOUNTING ANGLE (NOT BY MANUFACTURER) MUST BE USED AT EITHER THE HEAD AND/OR SILL. THE ALTERNATE ANGLE CAN SPAN A LARGER GAP BETWEEN THE LOUVER FRAME AND THE SUBSTRATE, WHICH ALLOWS FOR MORE CLEARANCE BETWEEN THE LOUVER FRAME AND THE ANCHOR. REFER TO THE "ALTERNATE CONTINUOUS MOUNTING ANGLE ALLOWABLE SETUPS" TABLE FOR DESIGN INFORMATION. NOTE THAT THE STANDARD CONTINUOUS MOUNTING ANGLE CAN HAVE ITS FRAME FASTENER HOLES DRILLED IN A NEW LOCATION OF UP TO 0.75" [19mm] AWAY FROM THE OUTSIDE CORNER OF THE STANDARD ANGLE (SEE NOTES 1 & 2 ON THE LOUVER'S MIAMI-DADE NOA "ALTERNATE CONTINUOUS MOUNTING ANGLE ALLOWABLE SETUPS" TABLE).

**CAUTION!** NO MATTER WHAT TYPE OF CONTINUOUS MOUNTING ANGLE IS USED IN AN INVERTED SETUP, A LARGER THAN TYPICAL HEAD/SILL SUBSTRATE GAP CLEARANCE SHOULD BE CONSIDERED WHEN SIZING THE LOUVER IN ORDER TO MAKE SURE THE HEAD/SILL FRAME CAN SLIDE OVER AND PAST THE ANCHOR HEADS ON THE INVERTED MOUNTING ANGLE(S).

**ANGLE PROVIDER:** THE MANUFACTURER PROVIDES STANDARD CONTINUOUS MOUNTING ANGLES ONLY. ANY NEEDED ALTERNATE CONTINUOUS MOUNTING ANGLE IS BY OTHERS.

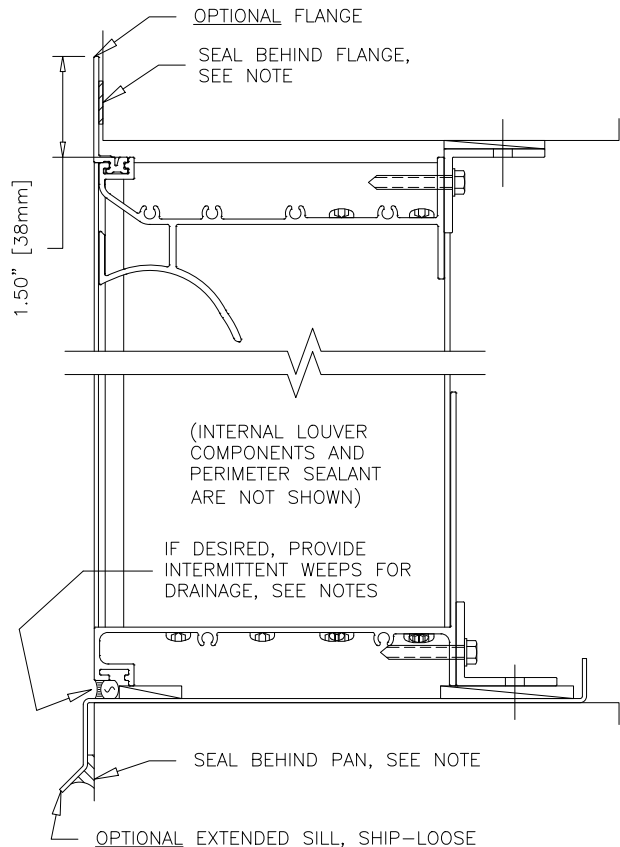

NOTE: SEALANT, BACKER ROD, NON-COMPRESSIBLE DEAD-LOA SHIMS, SEPARATION OF DISSIMILAR MATERIALS AND SUBSTRATE ARE NOT BY LOUVER MANUFACTURER, SHIM AS NEEDED, PERIMETER SEALANT REQUIRED TO PASS ANSI/AMCA 550 HIGH-VELOCITY WIND DRIVEN RAIN.

# FASTENER CHART

# EHV-550D

Florida Product Approval No.: FL30297  
 Miami-Dade, FL NOA No.: 19-0430.03 EXP. 08/15/2024  
 AMCA 540 and 550 Listed  
 Maximum Wind-load: 100 PSF

SUBSTRATE ANCHOR SPACING		
ACTUAL HEIGHT	< 48 IN.	> 48 IN.
ANCHOR SPACING	8 IN.	4 IN.

		SUBSTRATE MINIMUMS		ANCHOR MINIMUMS				
SUBSTRATE	THICKNESS	PROPERTY	ANCHOR TYPE	OVERALL	THREADED	EMBEDMENT	EDGE	Fy, Fu
TYPE	(IN.)			LENGTH (IN.)	LENGTH (IN.)	(IN.)	(IN.)	(KSI)
WOOD	3	SG 0.42	1/4 IN. LAG SCREW, COATED STEEL	3	2 1/2	2 1/2	1 1/2	70, 105
			1/4 IN. LAG SCREW, 300 SERIES STAINLESS (1)					65, 100
			1/4 IN. SPAX POWERLAG, HEX OR T-STAR WASHER HEAD, COATED STEEL					-
			6 MM SPAX TIMBER SCREW, WASHER HEAD, 300 SERIES STAINLESS	80 MM	61 MM	-	-	
STEEL	16 GA	Fy 33 KSI	1/4-14 SCREW, COATED STEEL (6)	VARIES (2)	VARIES (2)	FULL	1/2	65, -
			1/4-14 SCREW, 300 SERIES STAINLESS (1)					
			1/4-20 BOLT, 300 SERIES STAINLESS (1)			BOLTED		
ALUMINUM	1/8	Fy 25 KSI	1/4-20 SCREW, COATED STEEL (6)	VARIES (2)	VARIES (2)	FULL	1/2	65, -
			1/4-20 SCREW OR THRU BOLT, 300 SERIES STAINLESS (1)			FULL/BOLTED		
CONCRETE (3)	3	Fc 2.5 KSI	1/4 IN. DEWALT SCREW-BOLT+, COATED STEEL	VARIES (2)	VARIES (2)	2 1/2 NOM.	2	-
	4		3/8 IN. HILTI KWIK BOLT TZ EXPANSION, 304 OR 316 STAINLESS (5)			2 5/16 NOM.	3	
CRACKED CONCRETE (3)	4	Fc 2.5 KSI	3/8 IN. HILTI KWIK BOLT TZ EXPANSION, 304 OR 316 STAINLESS (5)	VARIES (2)	VARIES (2)	2 5/16 NOM.	3	-
GROUT FILLED CMU (4)	4x4x16	Fm 1.5 KSI	3/8 IN. DEWALT SCREW-BOLT+, COATED STEEL (5)	VARIES (2)	VARIES (2)	3 1/4 NOM.	1 1/2	-
			1/2 IN. THREADED ROD W/ HIT-HY 270 ADHESIVE, 300 SERIES STAINLESS (5)			4 1/2 EFF.	1 3/4	65, -

- 1) ANCHOR MANUFACTURING PROCESS IS COLD-WORKED.
- 2) AS NEEDED TO COMPLY WITH THE EMBEDMENT WHILE ACCOUNTING FOR THE THICKNESS OF THE MOUNTING ANGLE, SHIM(S), ETC.
- 3) NORMAL WEIGHT CONCRETE, INCLUDING PRE-CAST.
- 4) LIGHT/MEDIUM/NORMAL-WEIGHT CMU CONFORMING TO ASTM C90, TYPE II, GROUT FILLED CONFORMING TO C476.
- 5) THE 1/4 IN. DIA. ANCHOR CLEARANCE HOLES IN THE MANUFACTURER PROVIDED STANDARD CONTINUOUS MOUNTING ANGLE WILL NEED TO BE FIELD ENLARGED TO ACCEPT THE ANCHOR.
- 6) SCREWS WITH THREADS AS NOTED MAY BE EITHER ELCO'S DRIL-FLEX WITH STALGARD, OR BRYNOLF'S GR-5 WITH PROCORR.

# OPTION DRAWINGS

# EHV-550D

Florida Product Approval No.: FL30297  
 Miami-Dade, FL NOA No.: 19-0430.03 EXP. 08/15/2024  
 AMCA 540 and 550 Listed  
 Maximum Wind-load: 100 PSF

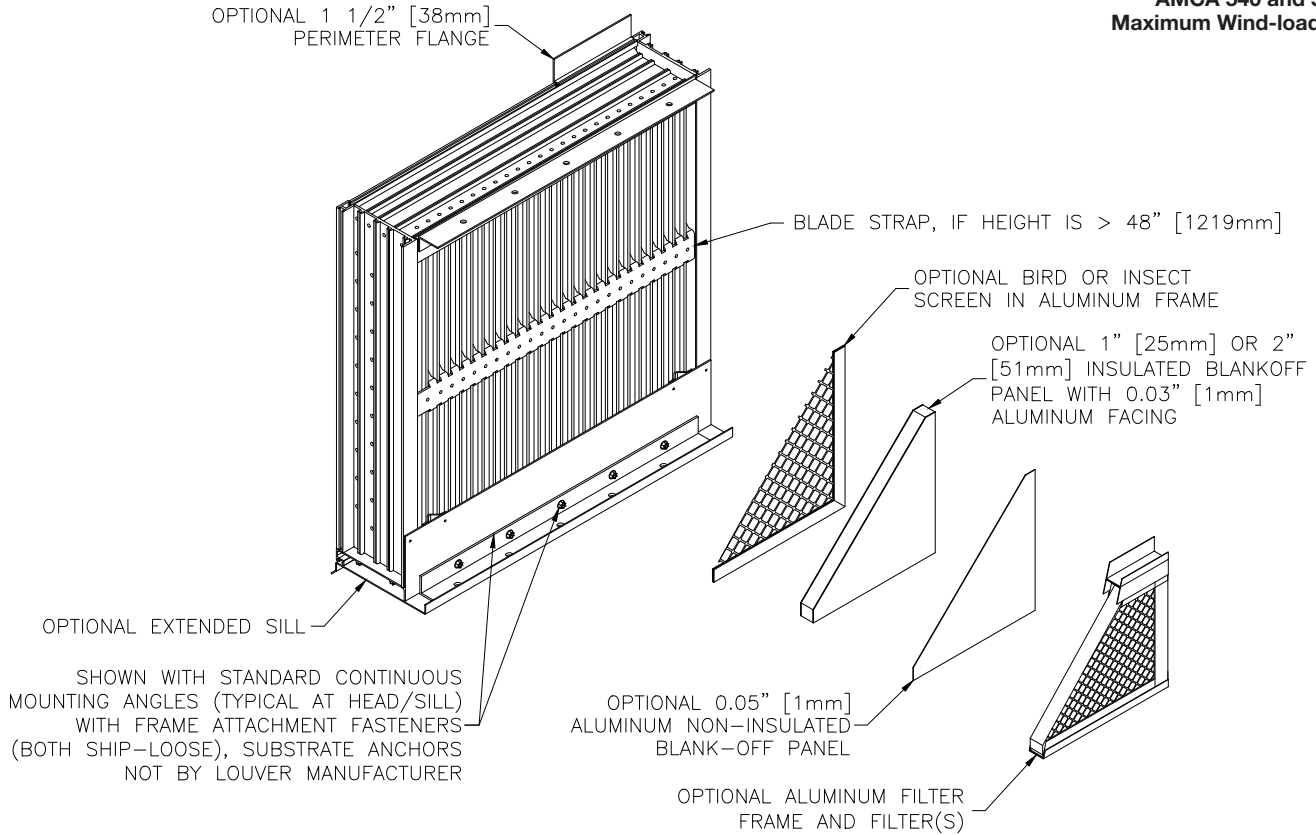

## FINISHES

Finish Type	Description/Application	Color Selection	Standard Warranty (Aluminum)
<b>AAMA 2605</b> 100% Fluoropolymer (FEVE) 2-Coat 70% Kynar® (PVDF) 3-Coat 70% Kynar® (PVDF) 4-Coat 70% Kynar® (PVDF)	<b>"Best."</b> The premier finish for extruded aluminum. Tough, long-lasting coating has superior color retention and abrasive properties. Resists chalking, fading, chemical abrasion and weathering.	<b>Standard Colors:</b> Any of the 27 standard colors shown can be furnished in 70% or 50% Kynar®, 100% Fluoropolymer or Baked Enamel.	10 Years (20 Years Optional)
<b>AAMA 2604</b> 50% Kynar® / Acroflur®	<b>"Better."</b> Tough, long-lasting coating has excellent color retention and abrasive properties. Resists chalking, fading, chemical abrasion and weathering.	<b>Mica Colors:</b> Greenheck offers 6 standard Mica colors for 70% Kynar® or 100% Fluoropolymer.	5 Years
<b>AAMA 2603</b> Baked Enamel	<b>"Good."</b> Provides good adhesion and resistance to weathering, corrosion and chemical stain.	<b>Custom Colors:</b> Custom color matching is available. Consult your Greenheck representative for cost and/or lead-time implications if a custom color is required.	1 Year
<b>AA-M10C22A2</b> Integral Color Anodize	"Two-step" anodizing is produced by following the normal anodizing step with a second, colorfast process.	Light, Medium, Dark or Extra Dark Bronze; Champagne; Black	5 years
<b>AA-M10C22A41</b> Clear Anodize 215 R-1	Clear, colorless and hard oxide aluminum coating that resists weathering and chemical attack.	Clear	5 years
<b>AA-M10C22A31</b> Clear Anodize 204	Clear, colorless and hard oxide aluminum coating that resists weathering and chemical attack.	Clear	1 Year
<b>Prime Coat</b>	Louvers or architectural products shall be cleaned, pre-treated and receive a prime coat finish suitable for field painting. Greenheck does not recommend prime coat or field painting of materials.		n/a
<b>Mill</b>	Materials may be supplied in natural aluminum or galvanized steel finish when normal weathering is acceptable and there is no concern for color or color change.		n/a

Finishes meet or exceed AAMA 2605, AAMA 2604, and AAMA 2603 requirements. Please consult [www.greenheck.com](http://www.greenheck.com) for complete information on standard and extended paint warranties. Paint finish warranties are not applicable to steel products.



EHV-550D  
 February 2020

Copyright © 2020 Greenheck Fan Corporation

Greenheck Fan Corporation reserves the right to make product changes without notice.