



# LOUVER TYPE SCH501X

Florida Product Approval No.: FL7708.3, 15720.3  
UL Classified: R25376

## FLORIDA BUILDING CODE APPROVED STORM CLASS™ LOUVER

<b>Visible Mullion Louver Type</b> .....	SCH501X
<b>Material</b> .....	Extruded Aluminum (Alloy 6063-T5)
<b>Stationary Blade</b> .....	0.081 in. (2.06 mm)
<b>Frame</b> .....	0.081 in. (2.06 mm)
<b>Louver Depth</b> .....	5 in. (127.0 mm)
<b>Free Area – 4 ft. x 4 ft. Unit</b> .....	6.80 sq. ft. (0.632 m <sup>2</sup> )
<b>Percent Free Area</b> .....	42.5%
<b>Free Area Velocity at Beginning Point of Water Penetration – 0.01 oz H<sub>2</sub>O/sq. ft. Free Area</b> ...	above 1,250 fpm (6.35 m/s)
<b>Air Volume Flow Rate at Beginning Point of Water Penetration – 4 ft. x 4 ft. Unit</b> .....	8,500 cfm (4.01 m <sup>3</sup> /s)
<b>Pressure Drop at Beginning Point of Water Penetration</b> .....	0.18 in. H <sub>2</sub> O (0.045 kPa)
<b>Wind-Driven Rain Water Penetration Data</b>	
Exterior Wind Velocity .....	29 mph (13 m/s)
Rainfall Rate .....	3 in. (75 mm)/hour
Effectiveness .....	99.1%
Core Ventilation Rate .....	787 fpm (4.0 m/s)
Exterior Wind Velocity .....	50 mph (22 m/s)
Rainfall Rate .....	8 in. (200 mm)/hour
Effectiveness .....	99.2%
Core Ventilation Rate .....	689 fpm (3.5 m/s)
<b>Maximum Qualified Wind Design Load*</b> .....	+/- 200 PSF (9.6 kPa)



IMPACT RESISTANT LOUVER  
Basic Protection Level D

See www.AMCA.org for all certified or listed products

This label does not signify AMCA airflow performance certification.



Florida Building Code approved for use in the High Velocity Hurricane Zone (HVHZ)

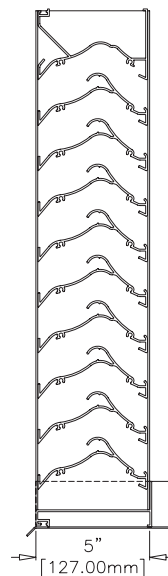

## RECOMMENDED SPECIFICATION

### GENERAL

Furnish and install where indicated on plans or described in schedules Storm Class™ Louver Type SCH501X as designed and manufactured by The Airolite Company LLC, Schofield, Wisconsin. Louvers shall be Florida Building Code approved for use in the High Velocity Hurricane Zone (HVHZ). Furnish louvers with bird screen, insect screen, sill pans, supports, installation hardware and finishes as specified and as required for a complete installation.

### SUBMITTALS

Manufacturer shall submit shop drawings incorporating key plans, elevations, sections and details showing profiles, angles and spacing of louver blades and frames; unit dimensions related to wall openings and construction; and, anchorage details and locations. For each type of product specified, submit free area, air performance, water penetration and wind driven rain water penetration ratings determined in accordance with AMCA Standard 500-L and licensed under the AMCA Certified Ratings Program, as well as tested in accordance with AMCA 540 Test Method for Louvers Impacted by Wind Borne Debris. Include Florida Building Code Approval for use in the High Velocity Hurricane Zone (HVHZ) as means to demonstrate compliance with applicable codes. Provide samples of manufacturer's finish and color charts showing the full range of colors available.

### PRODUCTS

Louvers shall be Storm Class™ Louver Type SCH501X with visible mullions and shall be Florida Building Code Approved. Louvers shall be 5-inches (127 mm) deep and assembled entirely from extruded aluminum components. Blades and frames shall be 0.081-inch (2 mm) thick aluminum, alloy 6063-T5. Blades shall be horizontal, inverted-V-type

with a center hook and spaced 2-inches (50.8 mm) on center.

### STRUCTURAL DESIGN CRITERIA

Louver Type SCH501X is tested and qualified per the following Florida test protocols: TAS 201 (Large Missile Impact), TAS 202 (Uniform Static Air Pressure) and TAS 203 (Cyclic Wind Loading). In addition, louvers shall be tested to wind forces up to 200 psf. Louvers must be secured to a structural substrate in accordance with Florida Building Code approved drawings. In addition, the structural substrate must be designed to accommodate the point loads transferred by the louvers when subject to the design wind loads. Structural reinforcing members along with any associated installation hardware is not provided by Airolite unless indicated otherwise by Airolite. Options and accessories are not subject to structural analysis unless indicated otherwise by Airolite.

### PERFORMANCE RATINGS

FREE AREA:	6.80 Square Feet ( 0.632 m <sup>2</sup> )
MINIMUM FREE AREA VELOCITY at Beginning Point of Water Penetration:	1,250 fpm (6.35 m/s)
MINIMUM AIR VOLUME FLOW RATE at Beginning Point of Water Penetration:	8,500 cfm (4.01 m <sup>3</sup> /s)
MAXIMUM STATIC PRESSURE at Beginning Point of Water Penetration:	0.18 in. H <sub>2</sub> O (0.045 kPa)

See page 5 for Wind-driven Rain Performance  
See page 6 for complete finish options

\*UL Classified as a Wind Restrictive Building Component in accordance with ASTM E330-02, Standard Test Method for Structural Performance of Exterior Windows, Doors, Skylights, and Curtain Walls by Uniform Static Air Pressure Difference (Florida Building Code TAS-202-94).

# LOUVER TYPE SCH501X PRODUCT DESCRIPTION & DETAILS

**AIROLITE LOUVER TYPE SCH501X** is a 5-inch (127 mm) deep, sightproof, horizontal blade Storm Class™ Louver that is Florida Building Code approved for use in the Wind-Borne Debris Zone and the High Velocity Hurricane Zone (HVHZ). Louver Type SCH501X is tested and qualified per the Florida test protocols: TAS 201 (Large Missile Impact), TAS 202 (Uniform Static Air Pressure) and TAS 203 (Cyclic Wind Loading). In addition, Louver Type SCH501X is rated 99.3% effective against water penetration at a core ventilation rate of 876 fpm (4.5 m/s) when tested at a 29 mph (13 m/s) wind velocity and 3 inch (75 mm) rainfall rate. Louver Type SCH501X is a highly effective louver with AMCA Licensed air performance, water penetration and wind-drive rain water penetration ratings, as well as tested in accordance with AMCA 540 Test Method for Louvers Impacted by Wind Borne Debris that enable designers to select and specify this product with confidence. Please contact your local Airolite representative or the factory for assistance with the layout and design of support systems when required.

## QUALIFIED SHAPES

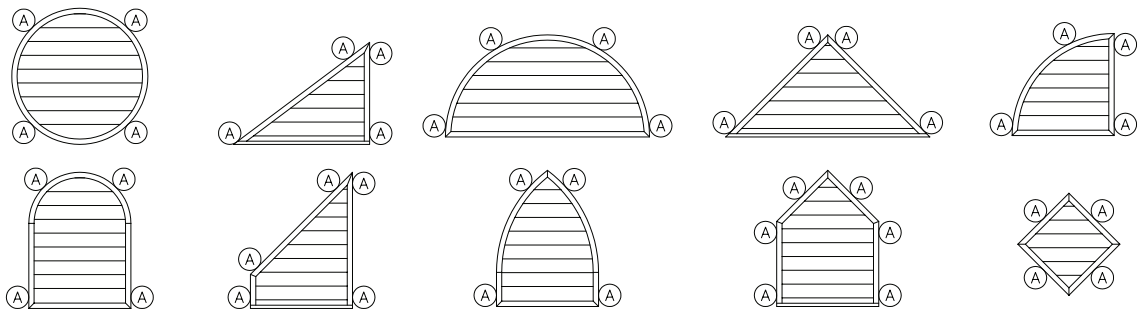
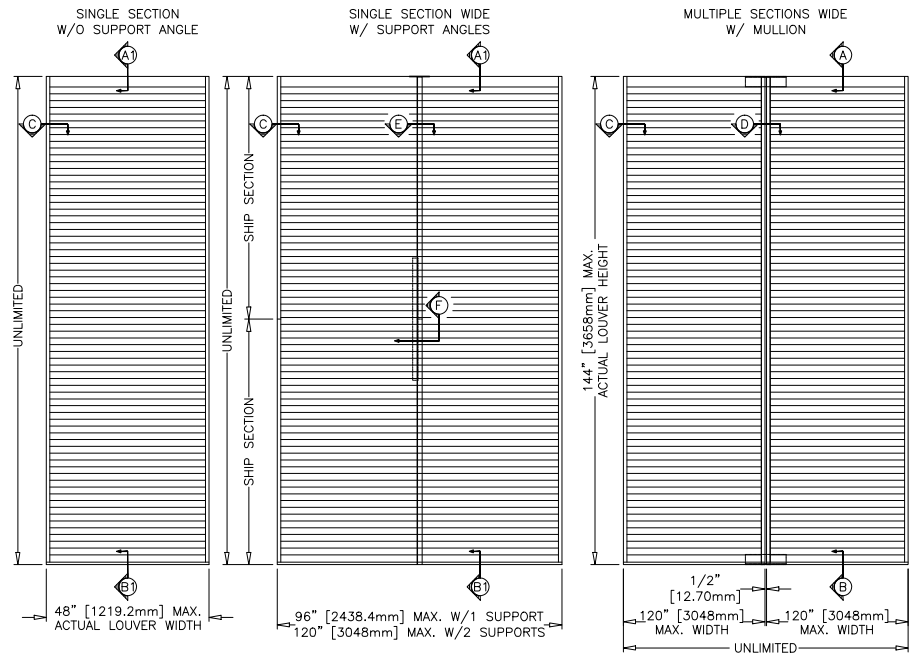

(A) Anchor points

# LOUVER TYPE SCH501X SECTION DETAILS

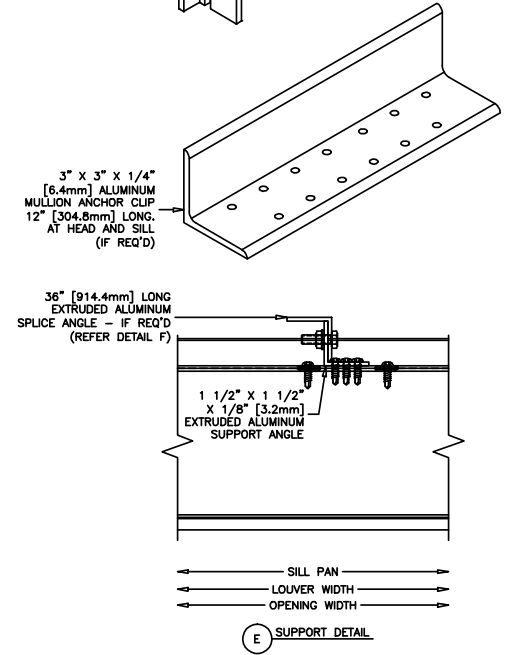
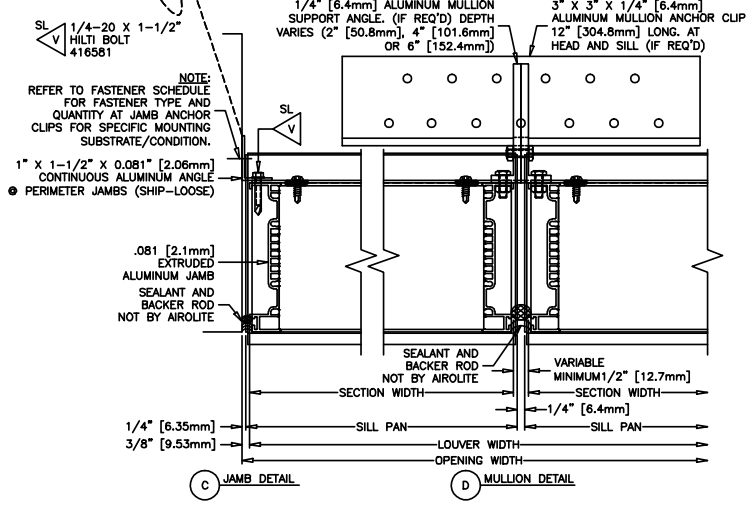
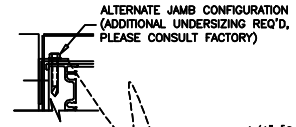
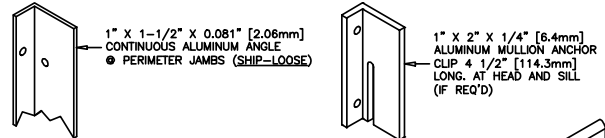
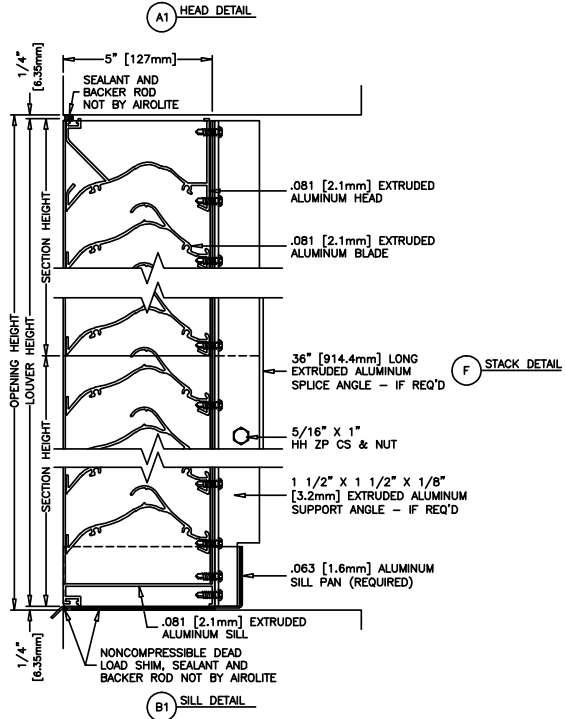
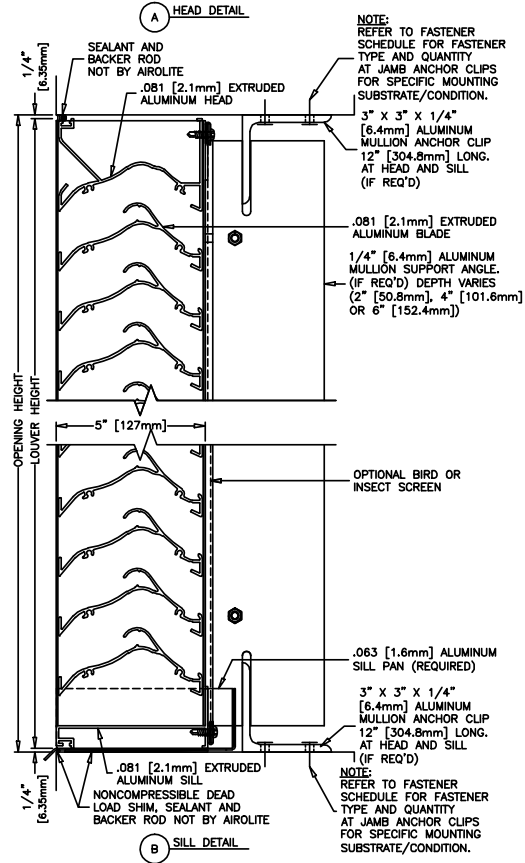

**Minimum Section Size:**  
12 in. (30 cm) W x 9 in. (23 cm) H

**Maximum Section Size:**  
120 in. (305 cm) W or 144 in. (366 cm) H  
(limited to 70 sq. ft.)

# LOUVER TYPE SCH501X INSTALLATION DETAILS

## WOOD OPENING

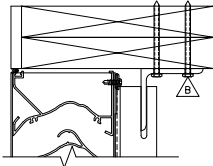

Ⓐ HEAD DETAIL AT MULLION

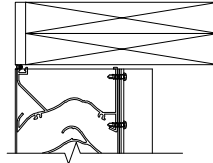

Ⓐ HEAD DETAIL AT BLADE SUPPORT

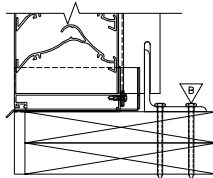

Ⓑ SILL DETAIL AT MULLION

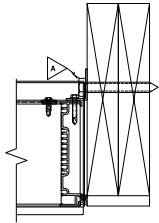

Ⓒ JAMB DETAIL

## MASONRY OPENING

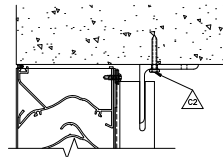

Ⓐ HEAD DETAIL AT MULLION

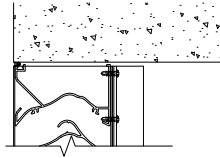

Ⓐ HEAD DETAIL AT BLADE SUPPORT

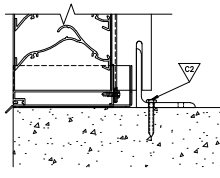

Ⓑ SILL DETAIL AT MULLION

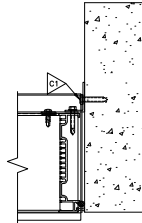

Ⓒ JAMB DETAIL

## STEEL STUD OPENING

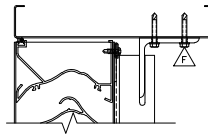

Ⓐ HEAD DETAIL AT MULLION

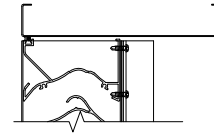

Ⓐ HEAD DETAIL AT BLADE SUPPORT

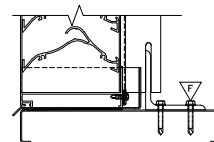

Ⓑ SILL DETAIL AT MULLION

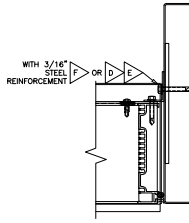

Ⓒ JAMB DETAIL

## STRUCTURAL STEEL OPENING

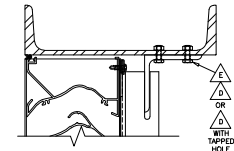

Ⓐ HEAD DETAIL AT MULLION

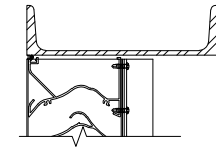

Ⓐ HEAD DETAIL AT BLADE SUPPORT

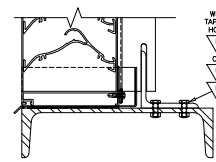

Ⓑ SILL DETAIL AT MULLION

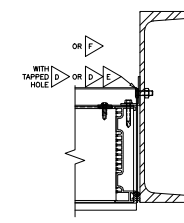

Ⓒ JAMB DETAIL

### FASTENER SCHEDULE (FIELD INSTALLED - NOT BY AIROLITE)

MOUNTING SUBSTRATE	FASTENER TYPE	DESCRIPTION	ANCHOR CLIP LOCATION	QUANTITY	MIN. EMBED.	MIN. EDGE DIST.	SPACING
WOOD	A	1/2" DIA. LAG SCREW	JAMB	VARIES	3"	2 1/2"	6.5"
WOOD	B	1/4" DIA. LAG SCREW	VERT. MULLION (HEAD/SILL)	12 PER CLIP	3"	1/2"	2"
CONCRETE	C1	1/4" DIA. TAPCON ANCH.	JAMB	VARIES	1.25"	1"	3.25"
CONCRETE	C2	1/4" DIA. TAPCON ANCH.	VERT. MULLION (HEAD/SILL)	7 PER CLIP	1.75"	2.5"	2"
MASONRY BLOCK	C1	1/4" DIA. TAPCON ANCH.	JAMB	VARIES	1.25"	1"	3.25"
MASONRY BLOCK	C2	1/4" DIA. TAPCON ANCH.	VERT. MULLION (HEAD/SILL)	7 PER CLIP	1.75"	2.5"	2"
STEEL STUD	D & E	1/4" DIA. BOLT & NUT	JAMB	VARIES	THRU BOLT	1/2"	6.5"
STEEL STUD (3/16" STEEL REINFORCED)	F	1/4" DIA. DRILL FLEX	JAMB	VARIES	FULL	1/2"	6.5"
STEEL STUD	G	1/4" DIA. DRILL FLEX	VERT. MULLION (HEAD/SILL)	12 PER CLIP	FULL	1/2"	2"
STRUCTURAL STEEL	D & E	1/4" DIA. BOLT & NUT	JAMB	VARIES	THRU BOLT	1/2"	6.5"
STRUCTURAL STEEL	D	1/4" DIA. BOLT	JAMB (FIELD DRILL & TAP HOLE)	VARIES	FULL	1/2"	6.5"
STRUCTURAL STEEL	F	1/4" DIA. DRILL FLEX	JAMB	VARIES	FULL	1/2"	6.5"
STRUCTURAL STEEL	D & E	1/4" DIA. BOLT & NUT	VERT. MULLION (HEAD/SILL)	4 PER CLIP	THRU BOLT	1/2"	6.5"
STRUCTURAL STEEL	D	1/4" DIA. BOLT	VERT. MULLION (HEAD/SILL) FIELD DRILL & TAP HOLE	4 PER CLIP	FULL	1/2"	6.5"
STRUCTURAL STEEL	F	1/4" DIA. DRILL FLEX	JAMB	VARIES	FULL	1/2"	6.5"

#### GENERAL NOTES:

- IT SHALL BE THE RESPONSIBILITY OF THE PERMIT HOLDER TO VERIFY THE STRUCTURAL INTEGRITY OF THE EXISTING STRUCTURE TO SUPPORT THE LOADS SUPERIMPOSED BY THE LOUVERS.
- INSTALLER TO PROVIDE SEPARATION OF DISSIMILAR MATERIALS AS REQUIRED.
- WOOD SUBSTRATE TO BE MINIMUM G = 0.42 DENSITY.
- CONCRETE SUBSTRATE TO BE MINIMUM 3,192 PSI CONCRETE OR 3,192 PSI GROUT FILLED ASTM C-90 HOLLOW BLOCK AT HEAD/SILL MULLION ANCHORS.
- CONCRETE SUBSTRATE TO BE MINIMUM 3,192 PSI CONCRETE OR ASTM C-90 HOLLOW BLOCK AT JAMB ANCHORS.
- STEEL STUD OPENINGS (16 GA. MINIMUM THICKNESS) TO BE MINIMUM Fy = 33 ksi.
- STRUCTURAL STEEL OPENINGS (1/4" MINIMUM THICKNESS) TO BE MINIMUM Fy = 36 ksi.

# LOUVER TYPE SCH501X PERFORMANCE RATINGS

## FREE AREA CHART - in square feet

Louver Height Inches	Louver Width in Inches																		
	12	18	24	30	36	42	48	54	60	66	72	78	84	90	96	102	108	114	120
7	0.06	0.11	0.15	0.19	0.23	0.27	0.31	0.34	0.38	0.42	0.46	0.50	0.54	0.58	0.62	0.65	0.69	0.73	0.77
12	0.20	0.33	0.45	0.58	0.71	0.83	0.96	1.05	1.18	1.30	1.43	1.56	1.68	1.81	1.93	2.03	2.16	2.28	2.41
18	0.41	0.66	0.91	1.17	1.42	1.68	1.93	2.12	2.38	2.63	2.89	3.14	3.39	3.65	3.90	4.09	4.35	4.60	4.86
24	0.61	0.99	1.38	1.76	2.14	2.52	2.91	3.19	3.58	3.96	4.34	4.72	5.11	5.49	5.87	6.16	6.54	6.92	7.31
30	0.81	1.33	1.84	2.35	2.86	3.37	3.88	4.26	4.77	5.29	5.80	6.31	6.82	7.33	7.84	8.22	8.73	9.25	9.76
36	1.02	1.66	2.30	2.94	3.58	4.22	4.85	5.33	5.97	6.61	7.25	7.89	8.53	9.17	9.81	10.29	10.93	11.57	12.21
42	1.22	1.99	2.76	3.53	4.29	5.06	5.83	6.40	7.17	7.94	8.71	9.47	10.24	11.01	11.78	12.35	13.12	13.89	14.66
48	1.43	2.32	3.22	4.12	5.01	5.91	6.80	7.47	8.37	9.27	10.16	11.06	11.95	12.85	13.75	14.42	15.31	16.21	17.10
54	1.63	2.66	3.68	4.70	5.73	6.75	7.78	8.54	9.57	10.59	11.62	12.64	13.67	14.69	15.71	16.48	17.51	18.53	19.55
60	1.84	2.99	4.14	5.29	6.45	7.60	8.75	9.62	10.77	11.92	13.07	14.22	15.38	16.53	17.68	18.55	19.70	20.85	22.00
66	2.04	3.32	4.60	5.88	7.16	8.44	9.73	10.69	11.97	13.25	14.53	15.81	17.09	18.37	19.65	20.61	21.89	23.17	24.45
72	2.25	3.65	5.06	6.47	7.88	9.29	10.70	11.76	13.17	14.57	15.98	17.39	18.80	20.21	21.62	22.68	24.08	25.49	26.90
78	2.45	3.99	5.52	7.06	8.60	10.14	11.67	12.83	14.36	15.90	17.44	18.98	20.51	22.05	23.59	24.74	26.28	27.81	29.35
84	2.65	4.32	5.99	7.65	9.32	10.98	12.65	13.90	15.56	17.23	18.89	20.56	22.22	23.89	25.56	26.80	28.47	30.14	31.80



The Aiolite Company, LLC certifies that Louver Type SCH501X shown herein is licensed to bear the AMCA seal. The ratings shown are based on tests and procedures performed in accordance with AMCA Publication 511 and comply with the requirements of the AMCA Certified Ratings Program. The AMCA Certified Ratings Seal applies to Water Penetration, Air Performance and Wind-driven Rain.



IMPACT RESISTANT LOUVER  
Basic Protection Level D

See www.AMCA.org for all certified or listed products

This label does not signify AMCA airflow performance certification.

The Aiolite Company, LLC certifies that Louver Type SCH501X shown herein is approved to bear the AMCA Listing Label. The ratings shown are based on tests and procedures performed in accordance with AMCA Publications and comply with the requirements of the AMCA Listing Label Program. The AMCA

Listing Label applies to Wind Borne Debris Impact Resistant Louvers.

## WATER PENETRATION

(Standard Air - .075 lb./ft.<sup>3</sup>; Test Size - 48 in. x 48 in.; Test Duration - 15 min.)

The AMCA Water Penetration Test provides a method for comparing various louver models and designs as to their efficiency in resisting the penetration of rainfall under specific laboratory test conditions. The beginning point of water penetration is defined as that velocity where the water penetration curve projects through 0.01 oz. of water (penetration) per sq. ft. of louver free area. These performance ratings do not guarantee a louver to be weather-proof or stormproof and should be used in combination with other factors including good engineering judgement in selecting louvers. **\*The beginning point of water penetration for Model SCH501X is above 1250 fpm (6.35 m/s) free area velocity.**

## WIND-DRIVEN RAIN PERFORMANCE

Free Area Ventilation Rate fpm (m/s)	Ventilation Air Core Velocity fpm (m/s)	76 mm/h (3 in/hr) Rainfall & 13 m/s (29 mph) Wind Velocity		202.4 mm/h (8 in/hr) Rainfall & 22 m/s (50 mph) Wind Velocity	
		Water Penetration Effectiveness %	Water Penetration Classification	Water Penetration Effectiveness %	Water Penetration Classification
0 (0)	0 (0)		A		A
198 (1.0)	98 (0.5)		A		A
397 (2.0)	197 (1.0)		A		A
595 (3.0)	295 (1.5)		A		A
795 (4.0)	394 (2.0)		A		A
992 (5.0)	492 (2.5)		A	99.1	A
1,192 (6.1)	591 (3.0)	99.7	A	99.2	A
1,390 (7.1)	689 (3.5)	99.4	A	99.2	A
1,587 (8.1)	787 (4.0)	99.1	A	98.9	B
1,787 (9.1)	886 (4.5)	98.7	B	98.7	B
1,985 (10.1)	984 (5.0)	97.9	B	94.4	C

Discharge Loss Coefficient Class (Intake) = 3

Weather louvers shall be classified by their ability to reject simulated rain. The table to the left shows different classifications based on the maximum simulated rain penetration per square meter (square feet) of louver. Water penetration rating at a given louver face velocity is determined by the water penetration while the louver is subjected to a selected simulated rainfall rate and wind velocity.

## AIRFLOW RESISTANCE

(Standard Air - .075 lb./ft.<sup>3</sup>)

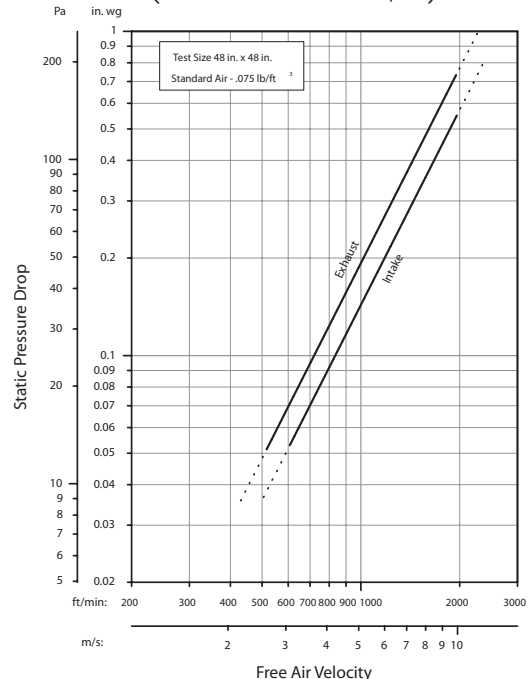

Louver Type SCH501X resistance to airflow varies depending on louver application (air intake or air exhaust). Free area velocities (shown) are higher than the average velocity through the overall louver size. (Test Figure: 5.5-6.5)

Discharge Loss Coefficient Classifications	
Class	Discharge Loss Coefficient
1	0.4 and Above
2	0.3 to 0.399
3	0.2 to 0.299
4	0.199 and Below

Wind-driven Rain Penetration Classes	
Class	Effectiveness
A	1 to 0.99
B	0.989 to 0.95
C	0.949 to 0.80
D	Below 0.80

# LOUVER TYPE SCH501X METHOD OF INSTALLATION & ACCESSORY OPTIONS

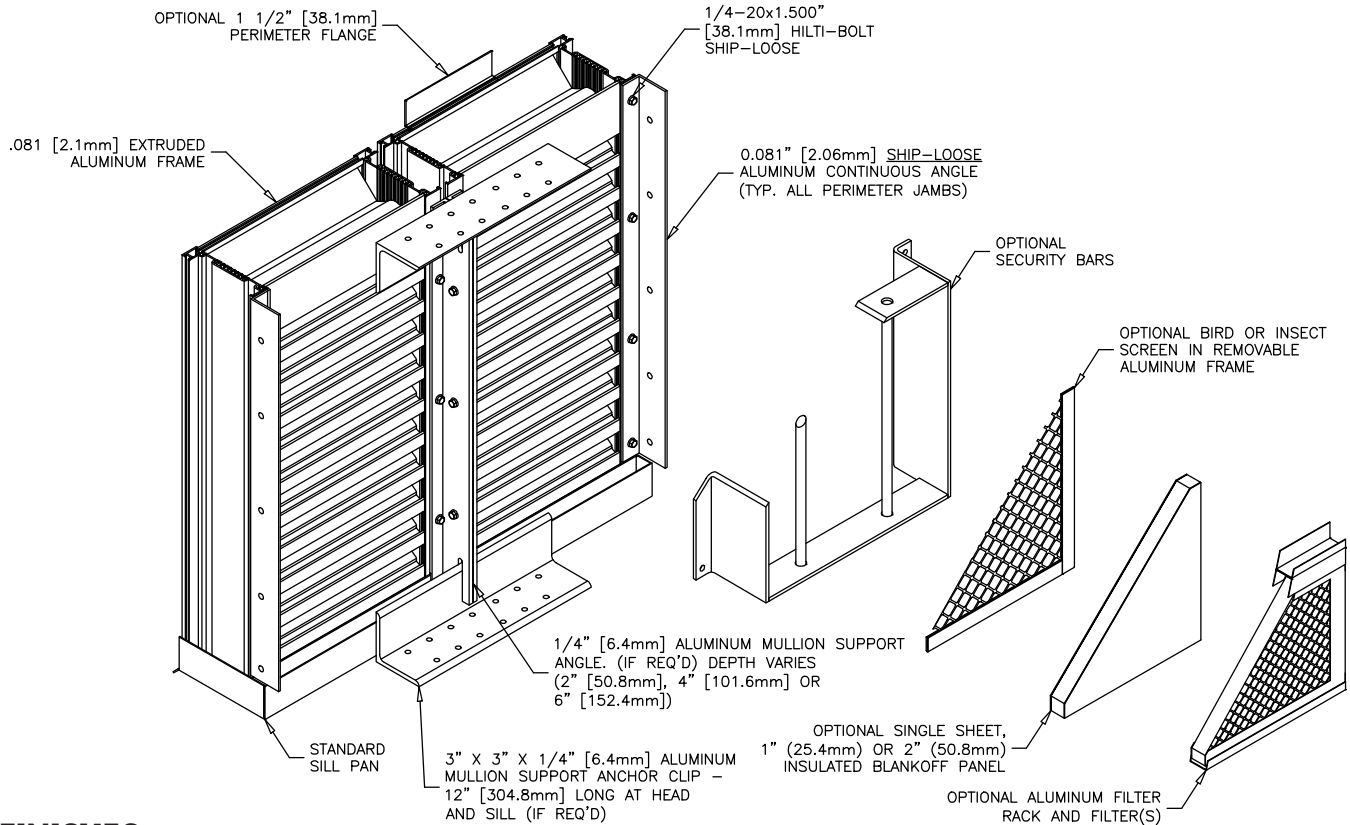

## FINISHES

Finish Type	Description/Application	Color Selection	Standard Warranty (Aluminum)
<b>AAMA 2605</b> 100% Fluoropolymer (FEVE) 2-Coat 70% Kynar® (PVDF) 3-Coat 70% Kynar® (PVDF) 4-Coat 70% Kynar® (PVDF)	"Best." The premier finish for extruded aluminum. Tough, long-lasting coating has superior color retention and abrasive properties. Resists chalking, fading, chemical abrasion and weathering.	<b>Standard Colors:</b> Any of the 27 standard colors shown can be furnished in 70% or 50% Kynar®, 100% Fluoropolymer or Baked Enamel. <b>Mica Colors:</b> Airlite offers 6 standard Mica colors for 70% Kynar® or 100% Fluoropolymer. <b>Custom Colors:</b> Custom color matching is available. Consult your Airlite representative for cost and/or lead-time implications if a custom color is required.	10 Years (20 Years Optional)
<b>AAMA 2603</b> Baked Enamel	"Good." Provides good adhesion and resistance to weathering, corrosion and chemical stain.		1 Year
<b>AA-M10C22A42</b> Integral Color Anodize	"Two-step" anodizing is produced by following the normal anodizing step with a second, colorfast process.	Light, Medium, Dark or Extra Dark Bronze; Champagne; Black	5 years
<b>AA-M10C22A41</b> Clear Anodize 215 R-1	Clear, colorless and hard oxide aluminum coating that resists weathering and chemical attack.	Clear	5 years
<b>AA-M10C22A31</b> Clear Anodize 204	Clear, colorless and hard oxide aluminum coating that resists weathering and chemical attack.	Clear	1 Year
<b>Prime Coat</b>	Louvers or architectural products shall be cleaned, pre-treated and receive a prime coat finish suitable for field painting. Airlite does not recommend prime coat or field painting of materials.		n/a
<b>Mill</b>	Materials may be supplied in natural aluminum or galvanized steel finish when normal weathering is acceptable and there is no concern for color or color change.		n/a

Finishes meet or exceed AAMA 2605, AAMA 2604, and AAMA 2603 requirements. Please consult [www.airlite.com](http://www.airlite.com) for complete information on standard and extended paint warranties. Paint finish warranties are not applicable to steel products.



P.O. Box 410, 525 Western Road, Schofield, WI 54476-0410 USA  
 715.841.8757 • fax 715.841.8773 • [www.airlite.com](http://www.airlite.com)

Submittal SCH501X June 2020  
 Copyright ©2020 The Airlite Company, LLC

The Airlite Company, LLC reserves the right to make product changes.