



BNC

PLENUM FAN

with Backward Curved Wheels



BNC Series

PLENUM FAN with Backward Curved Wheels



Kruger Ventilation (Taiwan) Co.,Ltd certifies that the **BNC Series** shown herein is licensed to bear the AMCA Seal. The ratings shown are based on tests and procedures performed in accordance with AMCA Publication 211 and AMCA Publication 311 and comply with the requirements of the AMCA Certified Ratings Program.



BNC Series

Plenum Fans – Backward curved wheels

Kruger Plenum Fans are designed for air handling application where the fan wheel operates without housing, inside a plenum. This results in saving of space normally occupied by the fan housing, transition and diffusers. The fan wheel pressurizes the entire plenum in which the fan is installed. This allows air ducts to be directly connected from any direction to the plenum. The compact size of the plenum fan makes it an excellent selection for retrofit and replacement application and for variable air volume systems.

There are three types of BNC Series, i.e. BNC-R (regular type), BNC-P (high pressure ratio type), BNC-Q (high volume ratio type).

NOMENCLATURE

MODEL: **BNC-R 450 / D I**

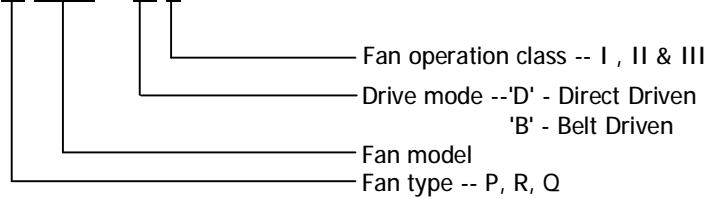

TYPE / OPERATING LIMIT

Each fan type has its maximum operating speed and power due to its mechanical design.

The operating limit of BNC series is set according to the requirement of class I, II and III limit as defined in AMCA standard 99.

The BNC series is available in Direct Driven and Belt Driven, Type D, B as follow:

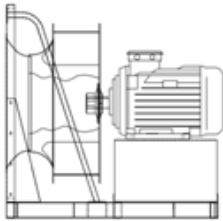

Direct Driven 'D'

This type is supplied with no belts nor pulley and therefore minimal maintenance is required. It is a compact, space saving design with motor directly connected to wheel. This construction is mainly for cleanroom, with or without VFD, since there is an absence of belt residue which may contaminate the airstreams.

Fan Size : 315 to 1,800
 Volume : 3,000 to 300,000 m³/h
 Total Pressure : up to 4,500 Pa

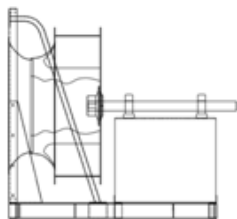

Belt Driven 'B'

No bearings in the fan inlet to affect performance. Separate base for motor mounting is required.

Fan Size : 315 to 1,800
 Volume : 3,000 to 300,000 m³/h
 Total Pressure : up to 4,500 Pa

Drawings and dimension data of belt driven are available upon request.

TECHNICAL SPECIFICATION

Wheel

The wheels of BNC series have backward curved blades manufactured in mild steel with polyester powder coating finish.

Shaft

Shafts are manufactured from C45 carbon steel using an automatic process for positioning and cutting of the keyways. All dimensional tolerances of the shaft are fully checked to ensure a precision fit. All shafts are then coated with an anti-corrosion varnish after assembly.



Bearing

Bearings used are either deep groove ball bearings with an adapter sleeve, or spherical roller bearings sealed at both sides for different duty application.

The bearings are lubricated for life and maintenance-free. If re-lubrication is necessary, it is recommended to use lithium base grease suitable for all temperatures within the operational limits.

Balancing Quality

All wheels are statically and dynamically balanced to ISO1940 and AMCA 204 – G2.5 standard.

All fans after assembly are trim-balanced to ISO1940 and AMCA 204 - G2.5 standard.

Other standard rather than G2.5 is available upon request.

ACCESSORIES

Inlet Guard

Inlet guards may be a requirement in some industrial safety regulations. These are available upon request.

Motor Selection

The power curves shown on each performance graph represents the absorbed power at the shaft of the fan measured in kW.

To determine the power of the motor to be installed, a correction factor should be applied to compensate for the transmission loss.

For conversion to horsepower (HP), use multiplying factor 1.34.

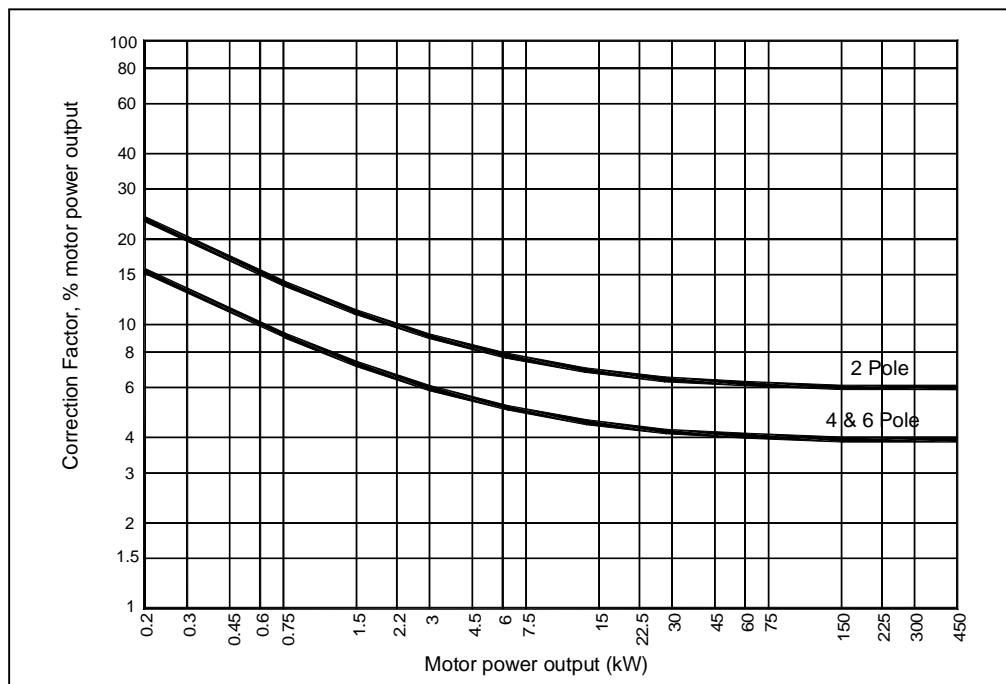

PERFORMANCE

The performance data shown on each diagram is derived from tests conducted in accordance with AMCA Standard 210 Fig 15 Installation type A (free inlet and free outlet condition).

Ratings refer to standard air density with the total pressure as a function of the air volume, using logarithmic scale.

It is essential that, the same installation type and test standards are used at all times, when comparing fan performance.

According to ISO 12759/AMCA 205, BNC series can be classify as FEG 80 based on fan peak efficiency. The following is the explanation of FEG classification:

1. Fan size is the impeller diameter in mm.
2. The fan peak efficiency shall be calculated from the fan (total) pressure.
3. If this method is used for a direct driven fan, the fan efficiency is the impeller efficiency.
4. The FEG label for a given fan size is assigned when the fan peak efficiency is equal or lower than the efficiency at the grade upper limit and higher than efficiency at the grade upper limit of the next lower grade for the fan size.
5. For any fan sizes larger than 1016 mm, the values of the grade upper limits are the same as for a size of 1016 mm.
6. No labels are considered for the fans with the fan peak total efficiency below FEG50.
7. The values of efficiencies are calculated for fan sizes in the preferred R40 Series.
8. Not all fan sizes in preferred numbers shown.

Fan Efficiency Grades (FEG) for Fans without Drives (SI) – ISO 12759/AMCA 205

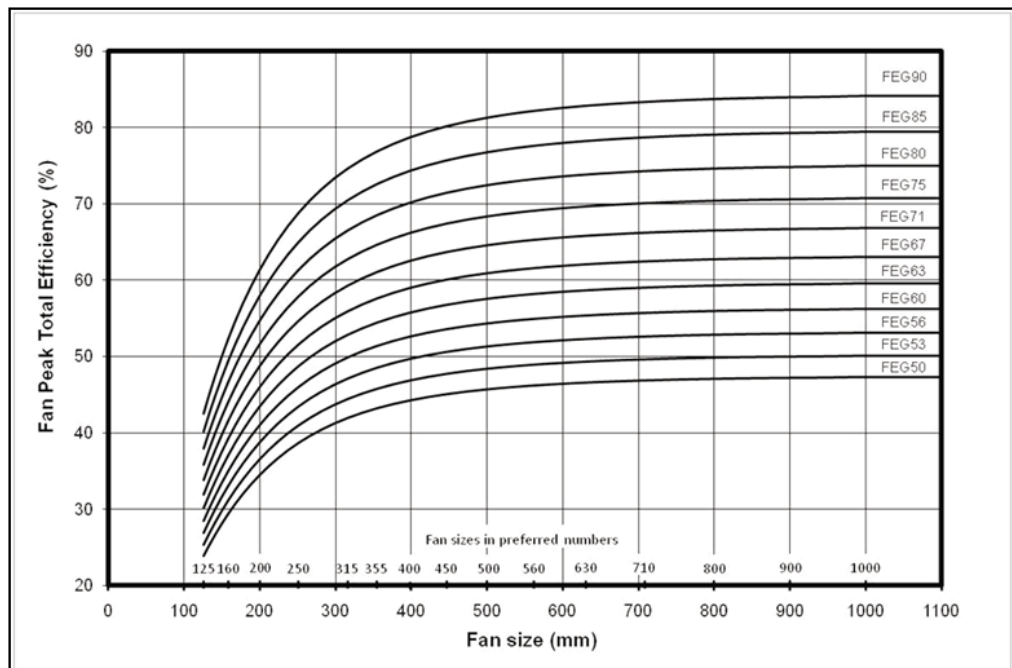

NOISE

The noise levels shown on each diagram refer to the sound power, "A-weighted" values and the data are obtained at the outlet side from tests conducted in accordance to AMCA Standard 300. The noise levels are determined as follow:

- n Sound power level - ("A" scale): L_w (A) as catalogue
- n Octave band spectrum: $L_w = L_w(A) + L_w \text{ rel. dB}$ [refer to Kruger for more details]
- n Sound pressure level:
 - a) free field
 $L_p(A) = L_w(A) - (20\log_{10}d) - 11$
 - b) room conditions
 $L_p(A) = L_w(A) - (20\log_{10}d) - 7$where d = distance of fan (m)

Example of Selection

Air Volume $Q=5000\text{m}^3/\text{h}$

Outlet Velocity $V=8.8\text{m/s}$

Dynamic Pressure $P_d=48\text{Pa}$

Total Pressure $P_t=900\text{Pa}$

Fan Speed $N=2200\text{rpm}$

Absorbed Power $W=1.7\text{kW}$

Total Efficiency $\eta=72\%$

Sound Power Level $L_w(A)=92.5\text{dB(A)}$

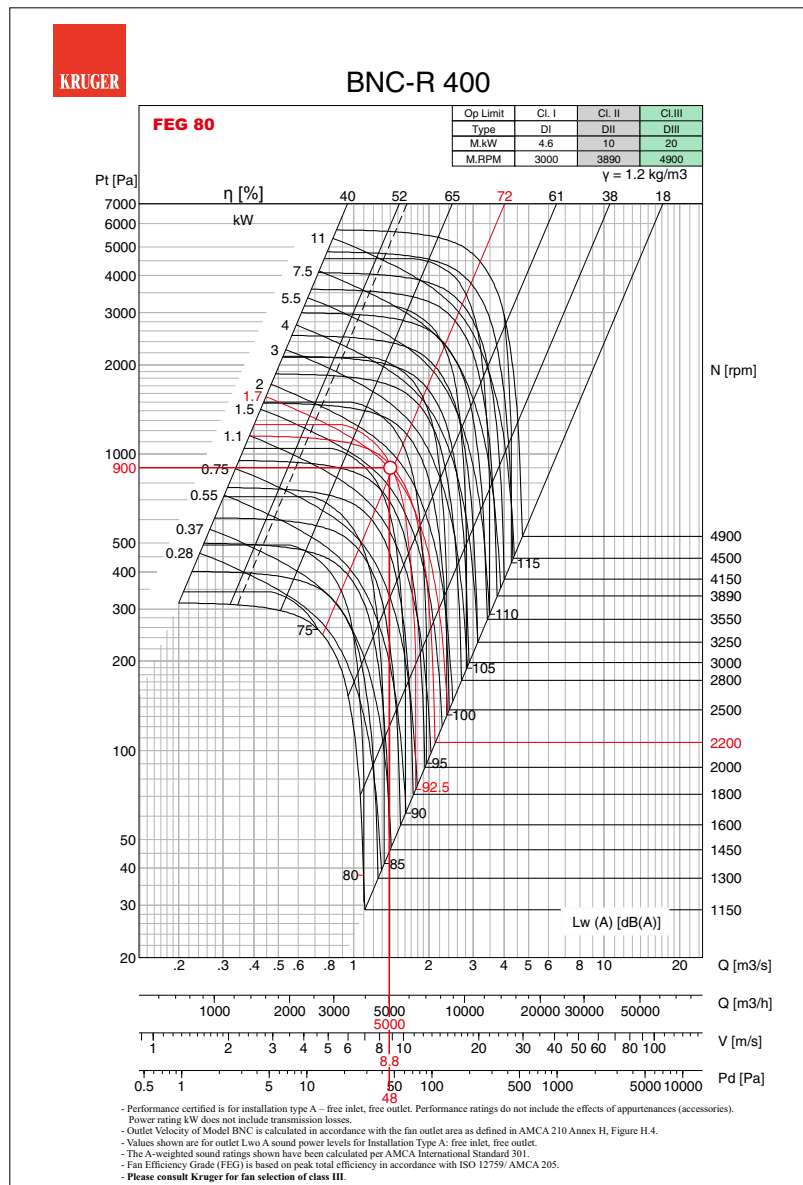



BNC-P 315

FEG 80

Op Limit	Cl. I	Cl. II	Cl. III
Type	DI	DII	DIII
M.kW	2.2	5	9.7
M.RPM	3500	4600	5800

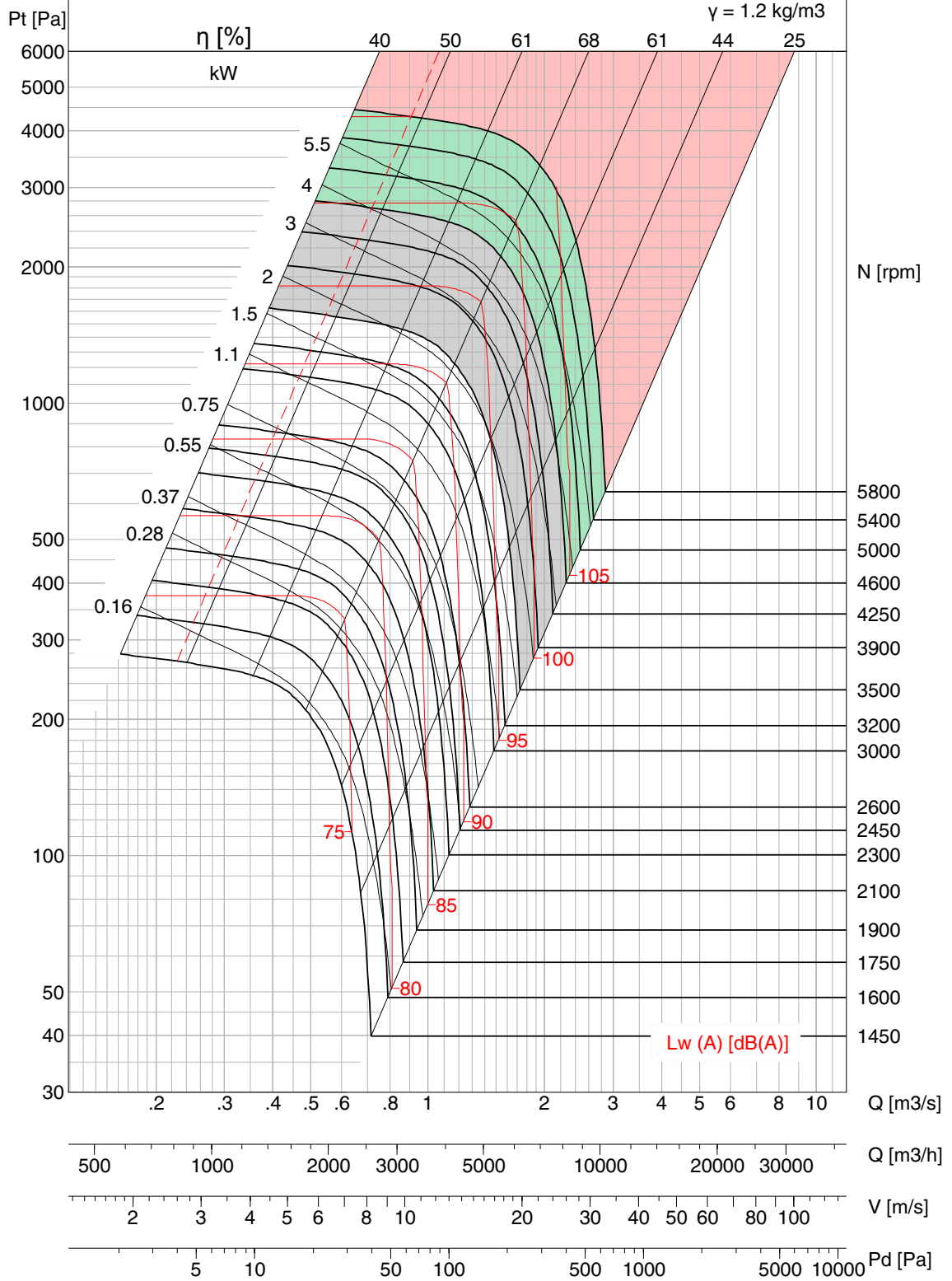

- Performance certified is for installation type A – free inlet, free outlet. Performance ratings do not include the effects of appurtenances (accessories). Power rating kW does not include transmission losses.
- Outlet Velocity of Model BNC is calculated in accordance with the fan outlet area as defined in AMCA 210 Annex H, Figure H.4.
- Values shown are for outlet Lwo A sound power levels for Installation Type A: free inlet, free outlet.
- The A-weighted sound ratings shown have been calculated per AMCA International Standard 301.
- Fan Efficiency Grade (FEG) is based on peak total efficiency in accordance with ISO 12759/ AMCA 205.
- Please consult Kruger for fan selection of class III.



BNC-R 315

FEG 80

Op Limit	Cl. I	Cl. II	Cl. III
Type	DI	DII	DIII
M.kW	2.4	5.2	10.4
M.RPM	3550	4600	5800

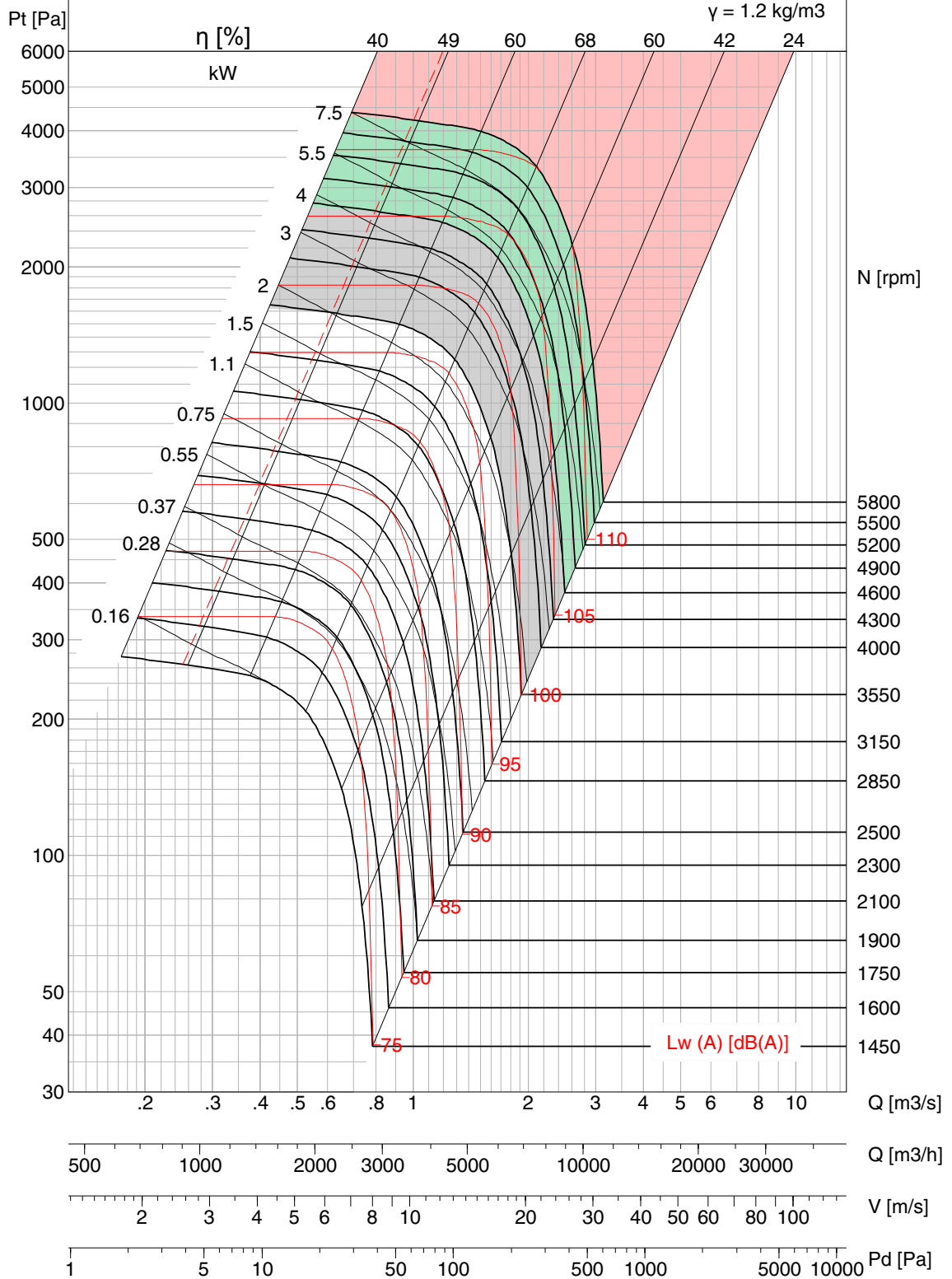

- Performance certified is for installation type A – free inlet, free outlet. Performance ratings do not include the effects of appurtenances (accessories).
- Power rating kW does not include transmission losses.
- Outlet Velocity of Model BNC is calculated in accordance with the fan outlet area as defined in AMCA 210 Annex H, Figure H.4.
- Values shown are for outlet Lwo A sound power levels for Installation Type A: free inlet, free outlet.
- The A-weighted sound ratings shown have been calculated per AMCA International Standard 301.
- Fan Efficiency Grade (FEG) is based on peak total efficiency in accordance with ISO 12759/ AMCA 205.
- Please consult Kruger for fan selection of class III.



BNC-Q 315

FEG 80

Op Limit	Cl. I	Cl. II	Cl. III
Type	DI	DII	DIII
M.kW	3	6.5	13
M.RPM	3700	4800	6100

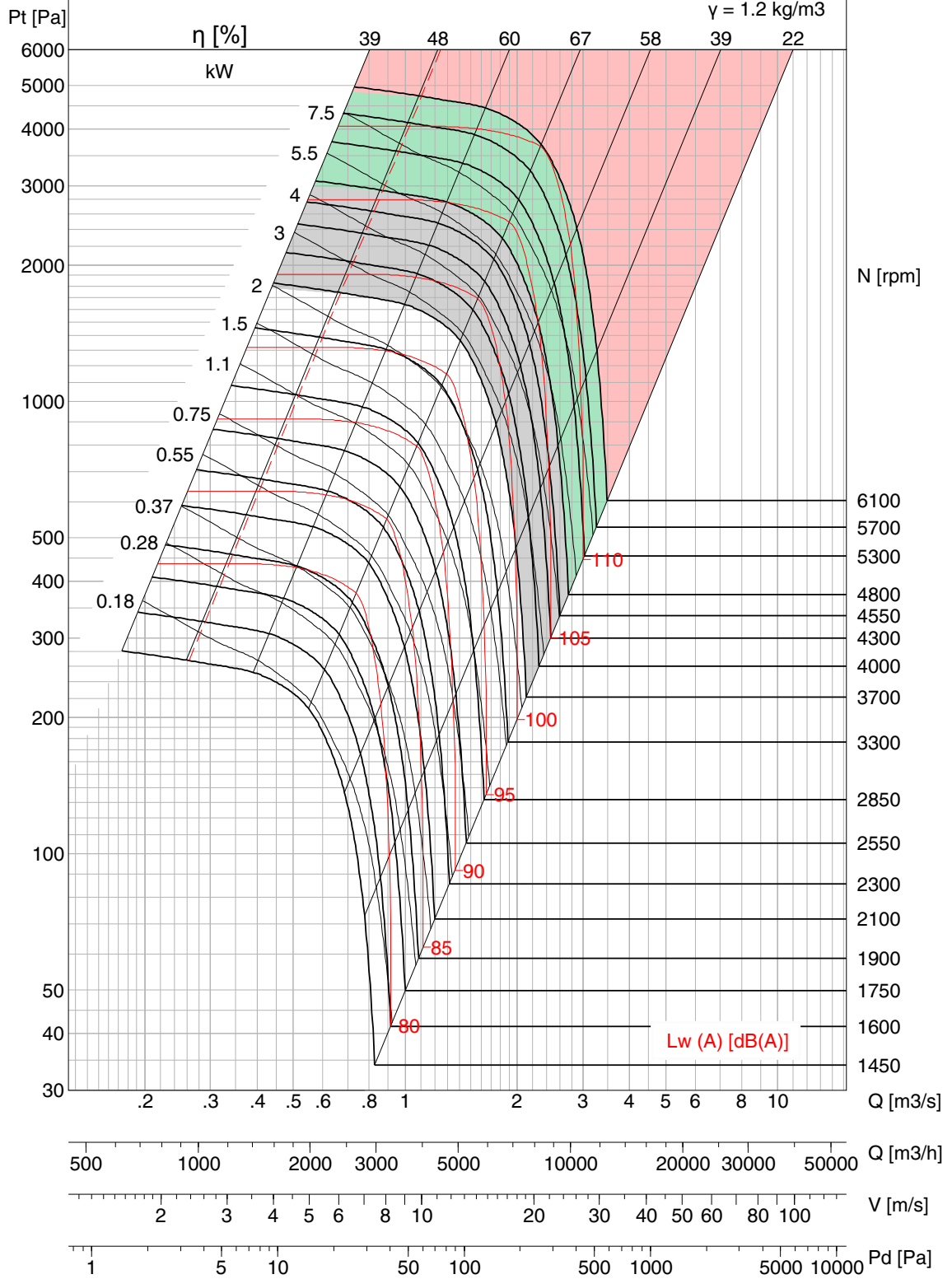

- Performance certified is for installation type A – free inlet, free outlet. Performance ratings do not include the effects of appurtenances (accessories).
- Power rating kW does not include transmission losses.
- Outlet Velocity of Model BNC is calculated in accordance with the fan outlet area as defined in AMCA 210 Annex H, Figure H.4.
- Values shown are for outlet Lwo A sound power levels for Installation Type A: free inlet, free outlet.
- The A-weighted sound ratings shown have been calculated per AMCA International Standard 301.
- Fan Efficiency Grade (FEG) is based on peak total efficiency in accordance with ISO 12759/ AMCA 205.
- Please consult Kruger for fan selection of class III.



BNC-P 355

FEG 80

Op Limit	Cl. I	Cl. II	Cl. III
Type	DI	DII	DIII
M.kW	3	6	11.5
M.RPM	3100	4000	5000

$\gamma = 1.2 \text{ kg/m}^3$

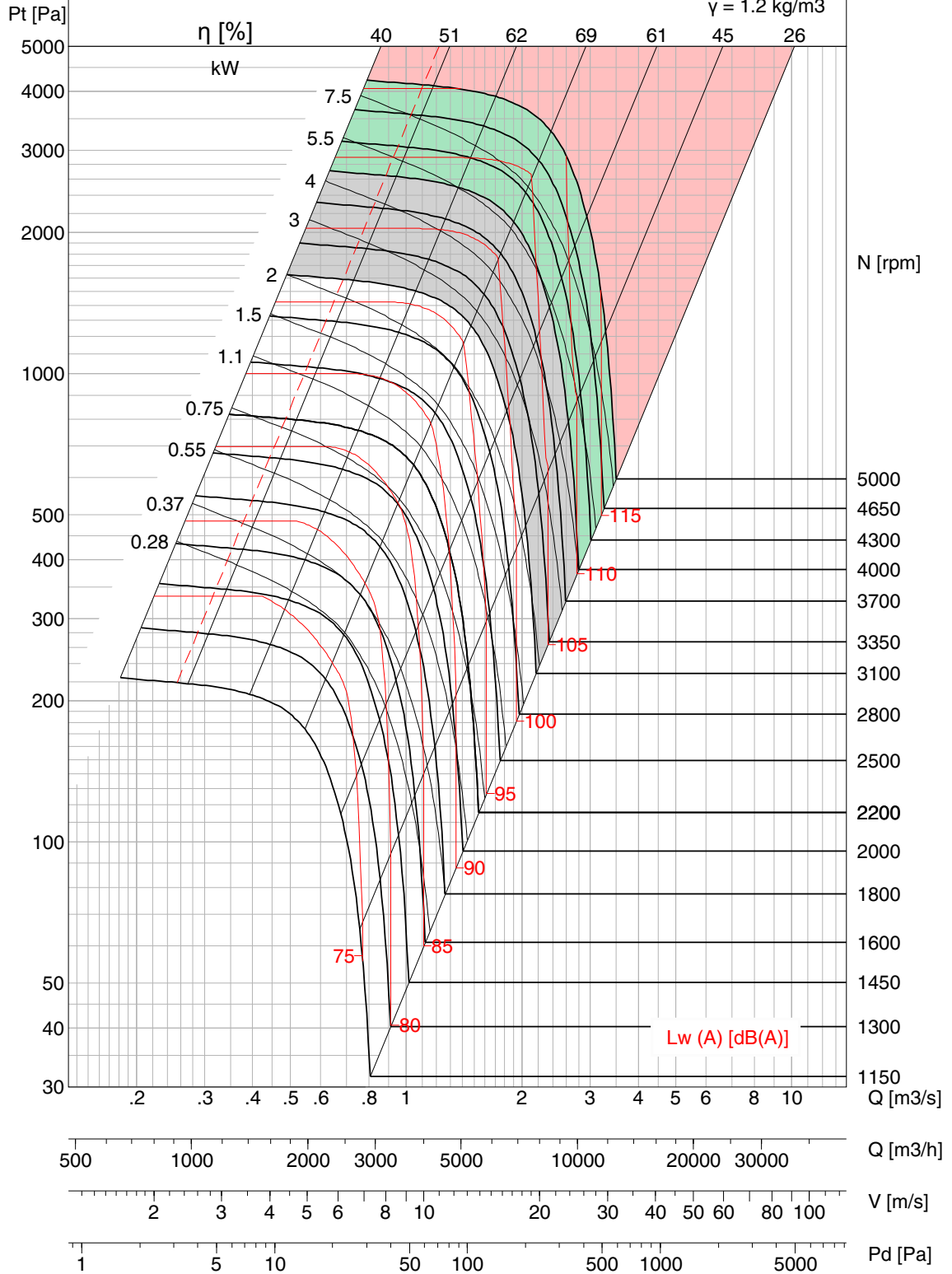

- Performance certified is for installation type A – free inlet, free outlet. Performance ratings do not include the effects of appurtenances (accessories). Power rating kW does not include transmission losses.
- Outlet Velocity of Model BNC is calculated in accordance with the fan outlet area as defined in AMCA 210 Annex H, Figure H.4.
- Values shown are for outlet Lwo A sound power levels for Installation Type A: free inlet, free outlet.
- The A-weighted sound ratings shown have been calculated per AMCA International Standard 301.
- Fan Efficiency Grade (FEG) is based on peak total efficiency in accordance with ISO 12759/ AMCA 205.
- Please consult Kruger for fan selection of class III.



BNC-R 355

FEG 80

Op Limit	Cl. I	Cl. II	Cl. III
Type	DI	DII	DIII
M.kW	3	6.8	13.3
M.RPM	3180	4150	5200

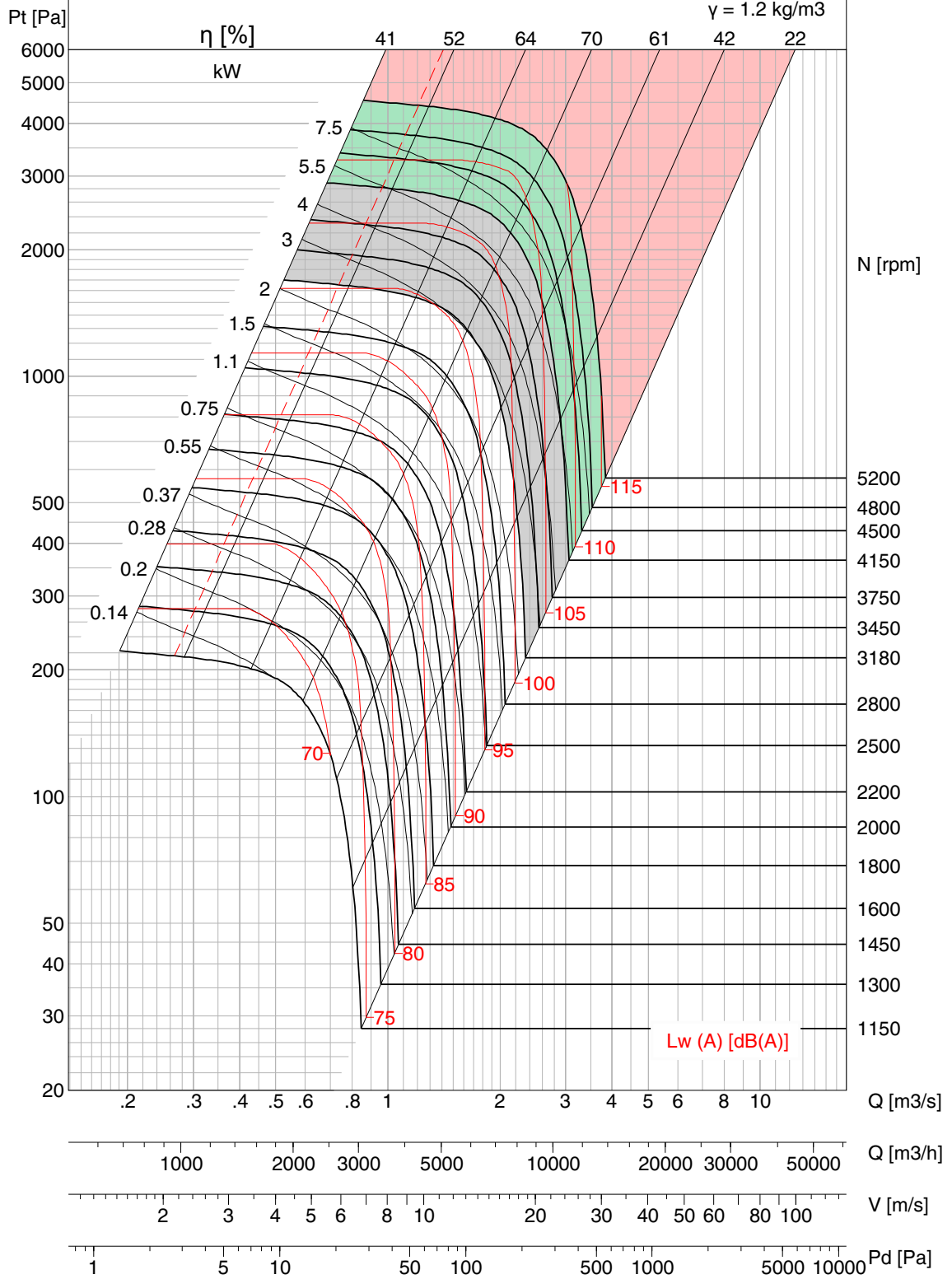

- Performance certified is for installation type A – free inlet, free outlet. Performance ratings do not include the effects of appurtenances (accessories).
- Power rating kW does not include transmission losses.
- Outlet Velocity of Model BNC is calculated in accordance with the fan outlet area as defined in AMCA 210 Annex H, Figure H.4.
- Values shown are for outlet Lwo A sound power levels for Installation Type A: free inlet, free outlet.
- The A-weighted sound ratings shown have been calculated per AMCA International Standard 301.
- Fan Efficiency Grade (FEG) is based on peak total efficiency in accordance with ISO 12759/ AMCA 205.
- Please consult Kruger for fan selection of class III.



BNC-Q 355

FEG 80

Op Limit	Cl. I	Cl. II	Cl. III
Type	DI	DII	DIII
M.kW	4	8.6	17
M.RPM	3370	4370	5500

$\gamma = 1.2 \text{ kg/m}^3$

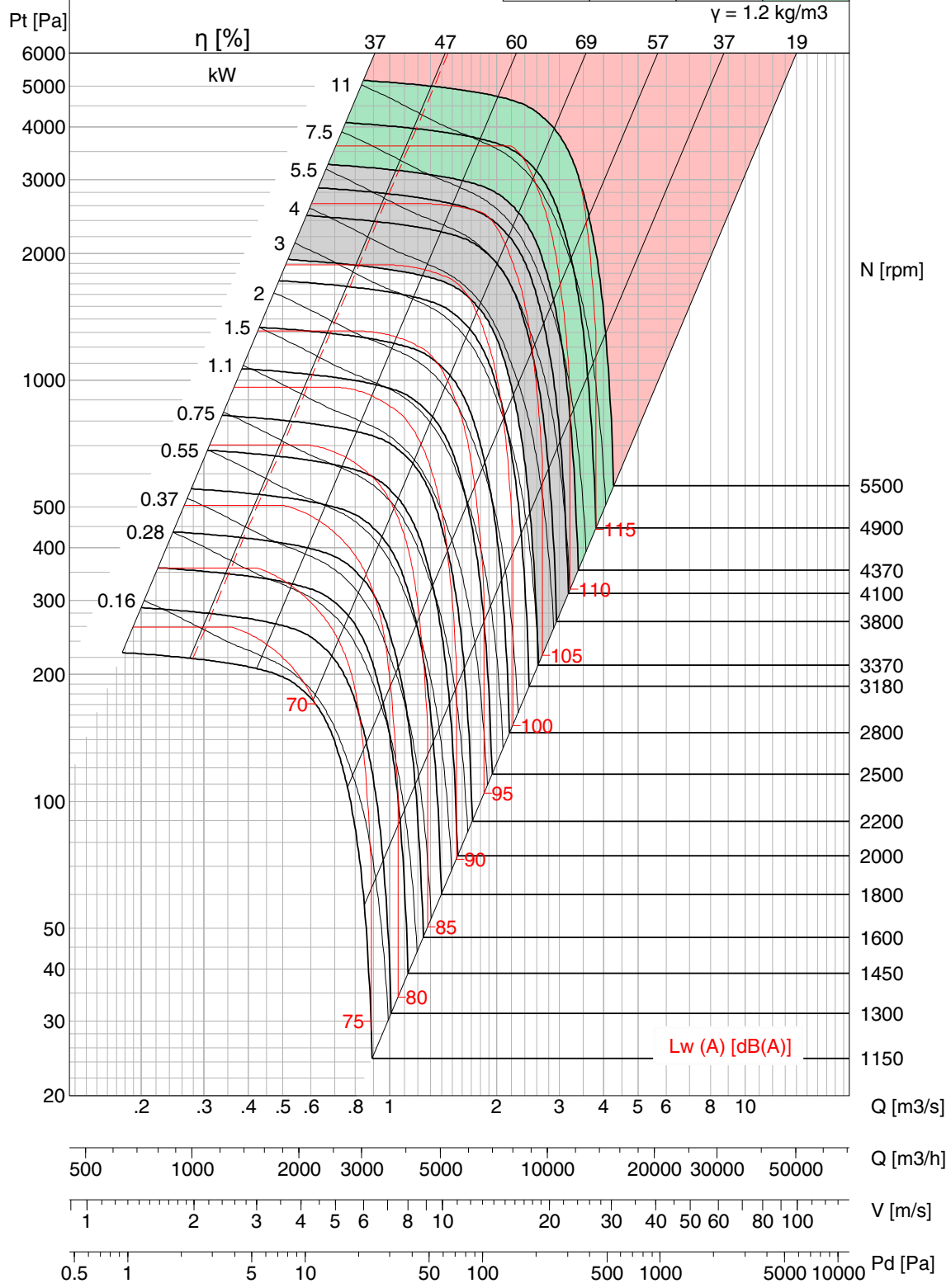

- Performance certified is for installation type A – free inlet, free outlet. Performance ratings do not include the effects of appurtenances (accessories). Power rating kW does not include transmission losses.
- Outlet Velocity of Model BNC is calculated in accordance with the fan outlet area as defined in AMCA 210 Annex H, Figure H.4.
- Values shown are for outlet Lwo A sound power levels for Installation Type A: free inlet, free outlet.
- The A-weighted sound ratings shown have been calculated per AMCA International Standard 301.
- Fan Efficiency Grade (FEG) is based on peak total efficiency in accordance with ISO 12759/ AMCA 205.
- Please consult Kruger for fan selection of class III.



BNC-P 400

FEG 80

Op Limit	Cl. I	Cl. II	Cl. III
Type	DI	DII	DIII
M.kW	3.3	7.2	14
M.RPM	2750	3550	4450

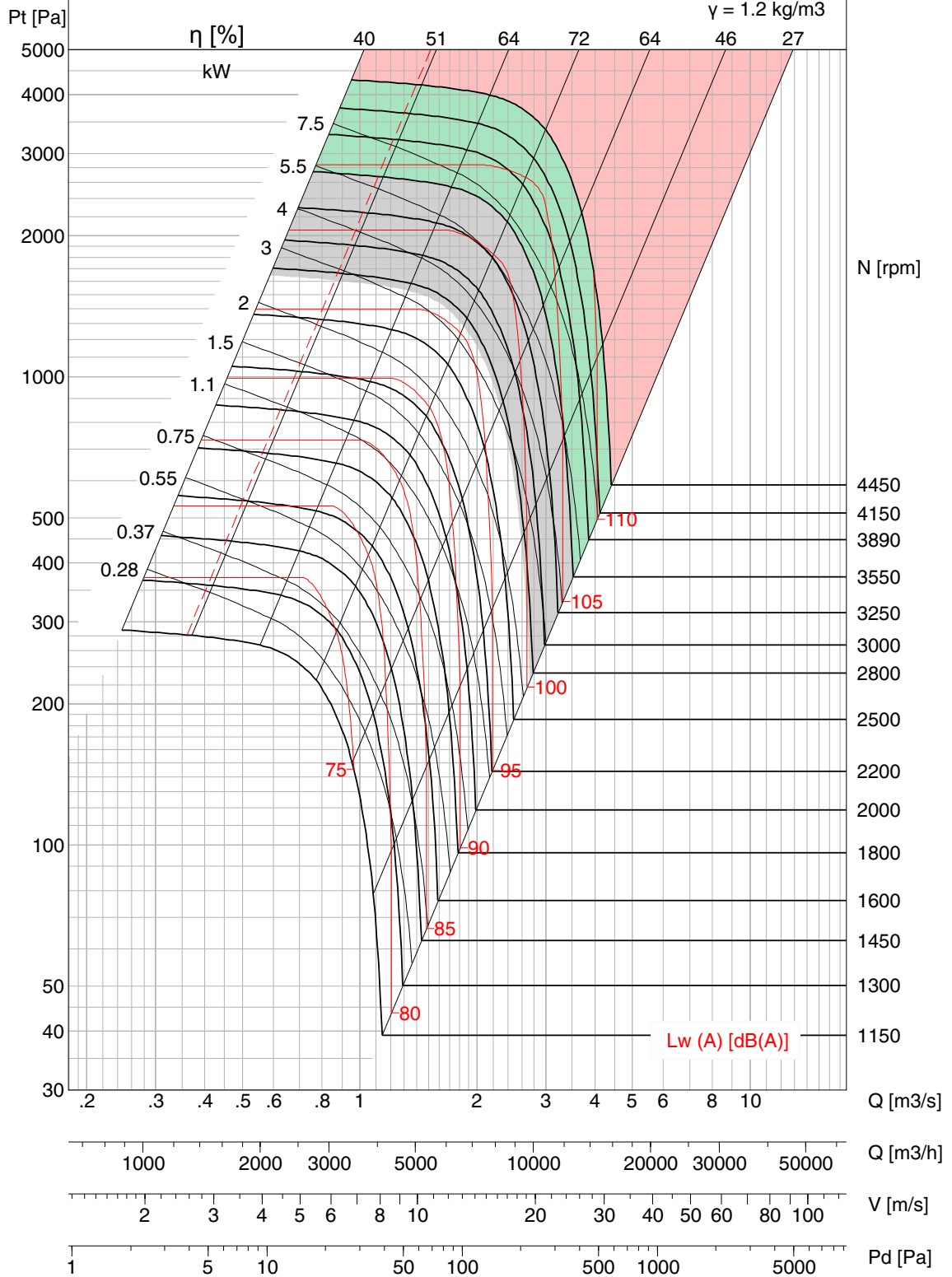

- Performance certified is for installation type A – free inlet, free outlet. Performance ratings do not include the effects of appurtenances (accessories). Power rating kW does not include transmission losses.
- Outlet Velocity of Model BNC is calculated in accordance with the fan outlet area as defined in AMCA 210 Annex H, Figure H.4.
- Values shown are for outlet Lwo A sound power levels for Installation Type A: free inlet, free outlet.
- The A-weighted sound ratings shown have been calculated per AMCA International Standard 301.
- Fan Efficiency Grade (FEG) is based on peak total efficiency in accordance with ISO 12759/ AMCA 205.
- Please consult Kruger for fan selection of class III.



BNC-R 400

FEG 80

Op Limit	Cl. I	Cl. II	Cl. III
Type	DI	DII	DIII
M.kW	4.6	10	20
M.RPM	3000	3890	4900

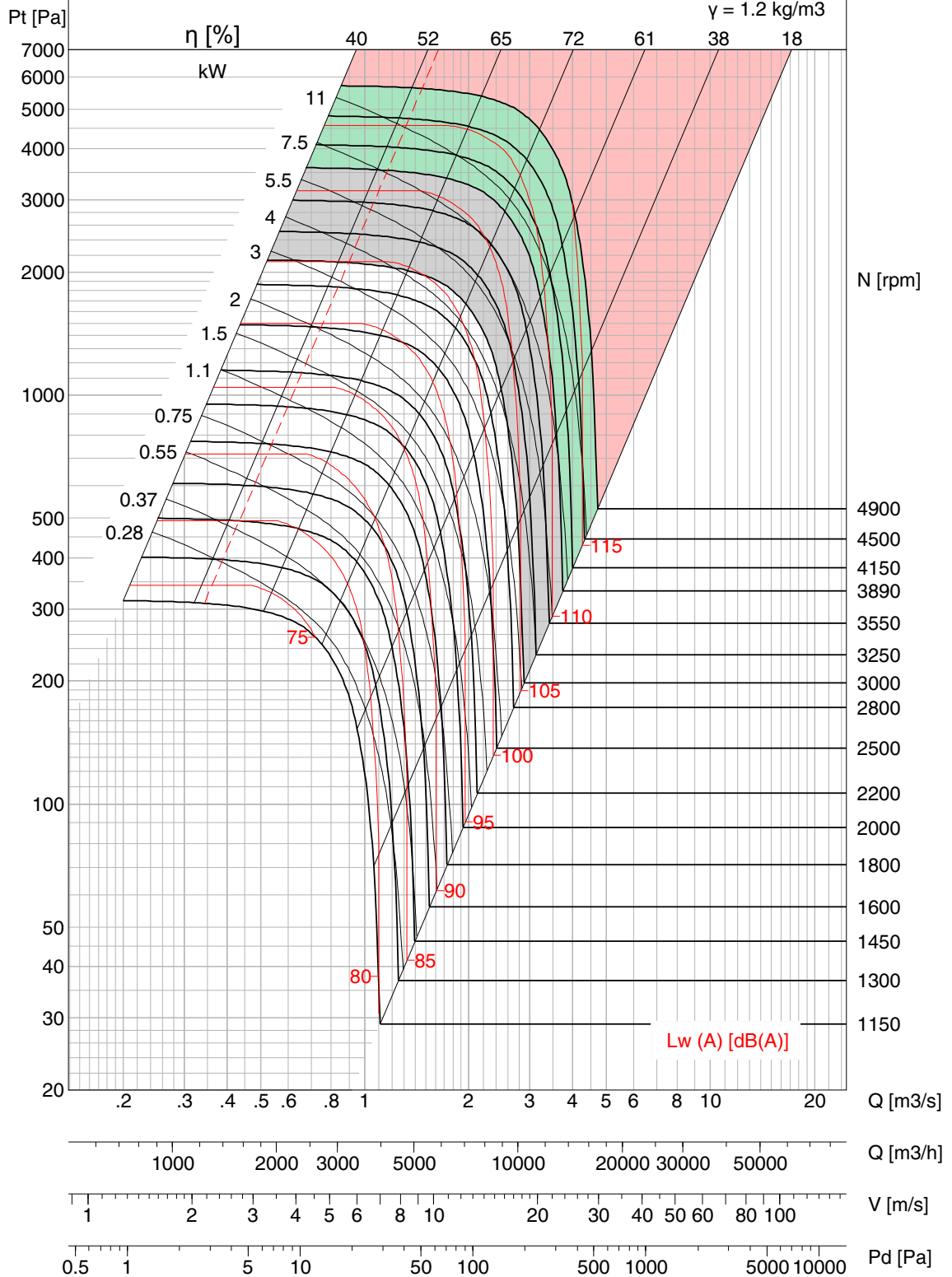

- Performance certified is for installation type A – free inlet, free outlet. Performance ratings do not include the effects of appurtenances (accessories). Power rating kW does not include transmission losses.
- Outlet Velocity of Model BNC is calculated in accordance with the fan outlet area as defined in AMCA 210 Annex H, Figure H.4.
- Values shown are for outlet Lwo A sound power levels for Installation Type A: free inlet, free outlet.
- The A-weighted sound ratings shown have been calculated per AMCA International Standard 301.
- Fan Efficiency Grade (FEG) is based on peak total efficiency in accordance with ISO 12759/ AMCA 205.
- Please consult Kruger for fan selection of class III.



BNC-Q 400

FEG 80

Op Limit	Cl. I	Cl. II	Cl. III
Type	DI	DII	DIII
M.kW	5	11	22
M.RPM	2900	3750	4750

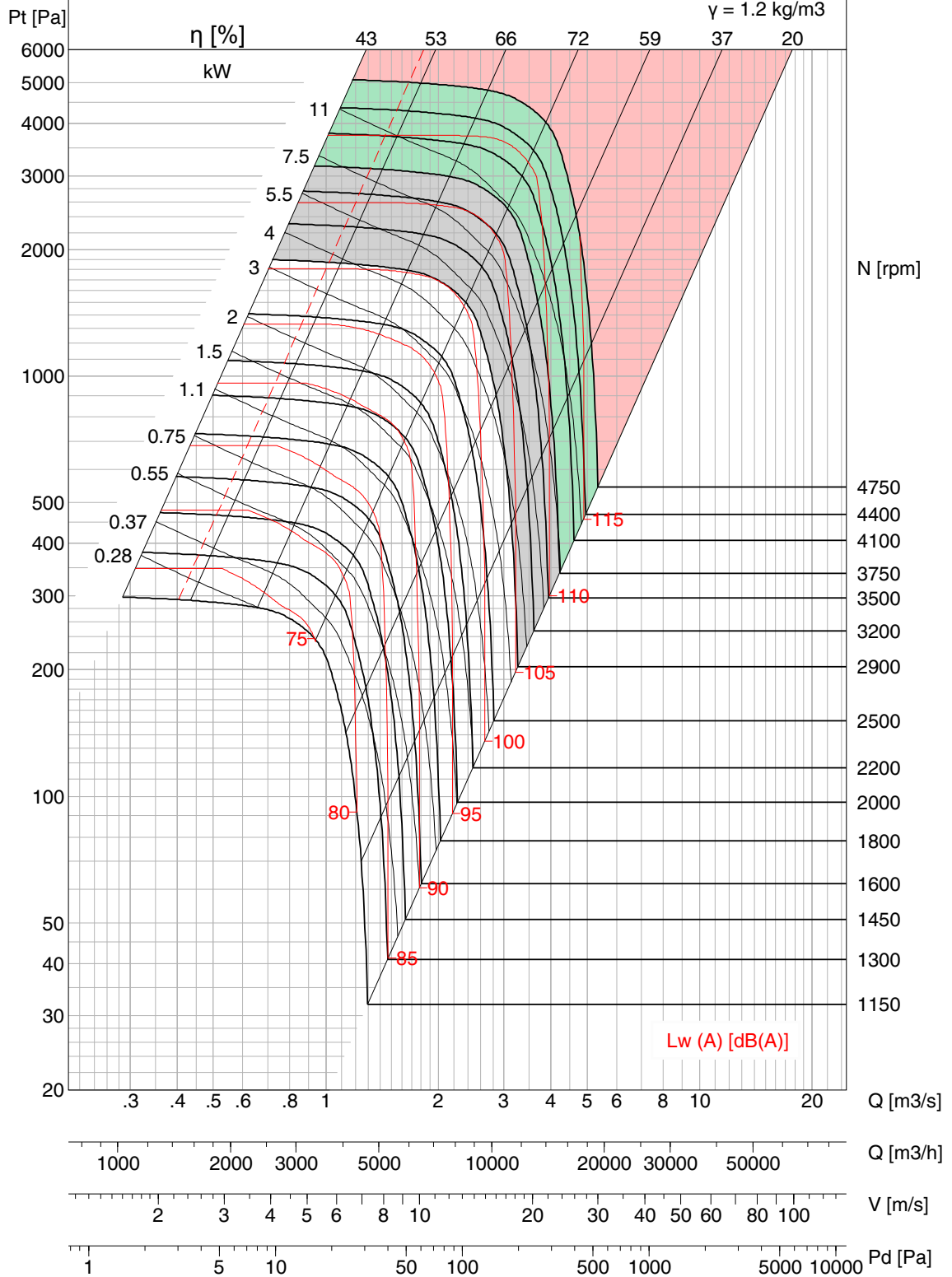

- Performance certified is for installation type A – free inlet, free outlet. Performance ratings do not include the effects of appurtenances (accessories).
- Power rating kW does not include transmission losses.
- Outlet Velocity of Model BNC is calculated in accordance with the fan outlet area as defined in AMCA 210 Annex H, Figure H.4.
- Values shown are for outlet Lwo A sound power levels for Installation Type A: free inlet, free outlet.
- The A-weighted sound ratings shown have been calculated per AMCA International Standard 301.
- Fan Efficiency Grade (FEG) is based on peak total efficiency in accordance with ISO 12759/ AMCA 205.
- Please consult Kruger for fan selection of class III.



BNC-P 450

FEG 80

Op Limit	Cl. I	Cl. II	Cl. III
Type	DI	DII	DIII
M.kW	4.3	9.5	19
M.RPM	2450	3170	4000

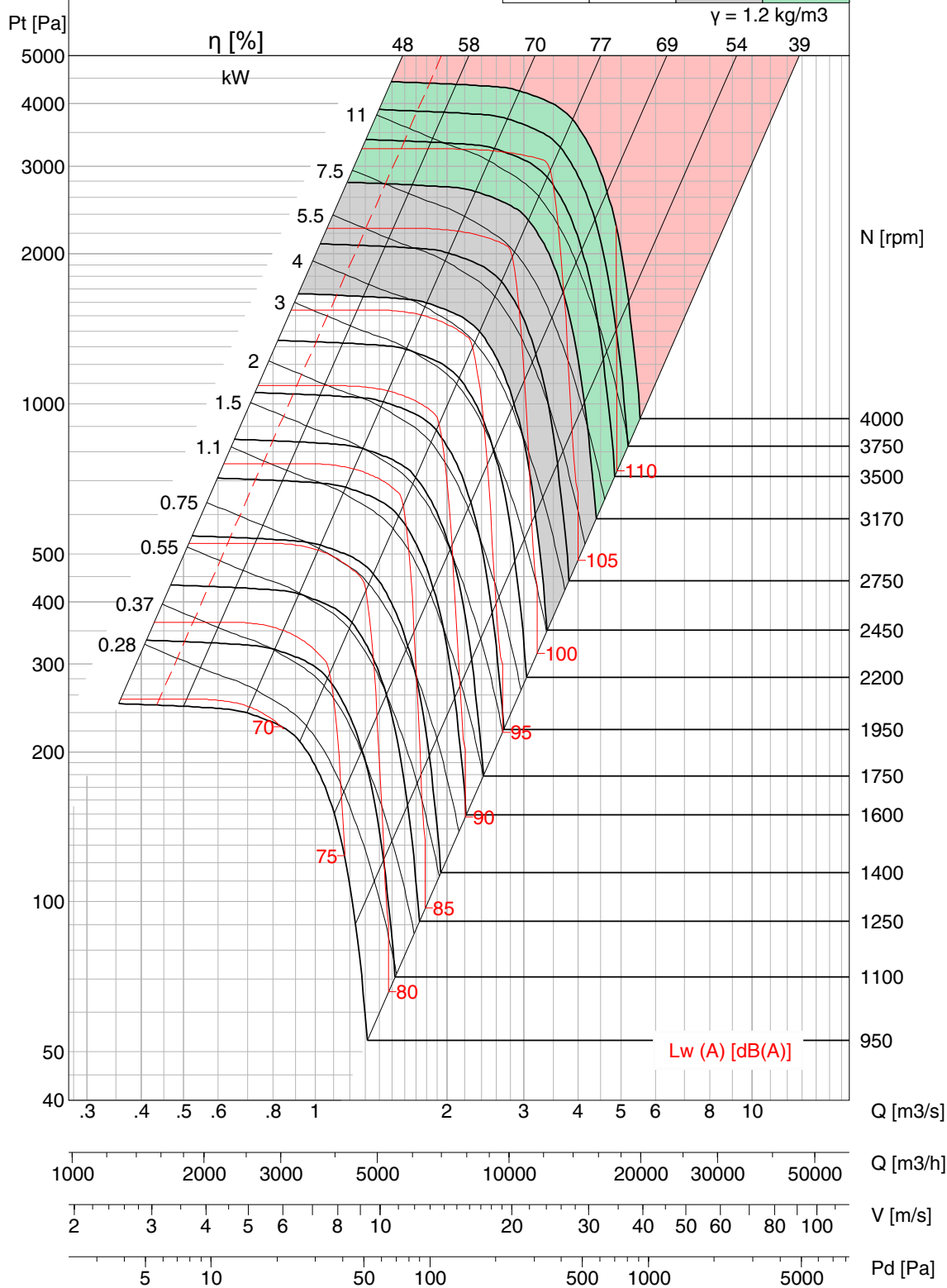

- Performance certified is for installation type A – free inlet, free outlet. Performance ratings do not include the effects of appurtenances (accessories).
- Power rating kW does not include transmission losses.
- Outlet Velocity of Model BNC is calculated in accordance with the fan outlet area as defined in AMCA 210 Annex H, Figure H.4.
- Values shown are for outlet Lwo A sound power levels for Installation Type A: free inlet, free outlet.
- The A-weighted sound ratings shown have been calculated per AMCA International Standard 301.
- Fan Efficiency Grade (FEG) is based on peak total efficiency in accordance with ISO 12759/ AMCA 205.
- Please consult Kruger for fan selection of class III.



BNC-R 450

FEG 80

Op Limit	Cl. I	Cl. II	Cl. III
Type	DI	DII	DIII
M.kW	4.6	10.6	21.5
M.RPM	2470	3200	4050

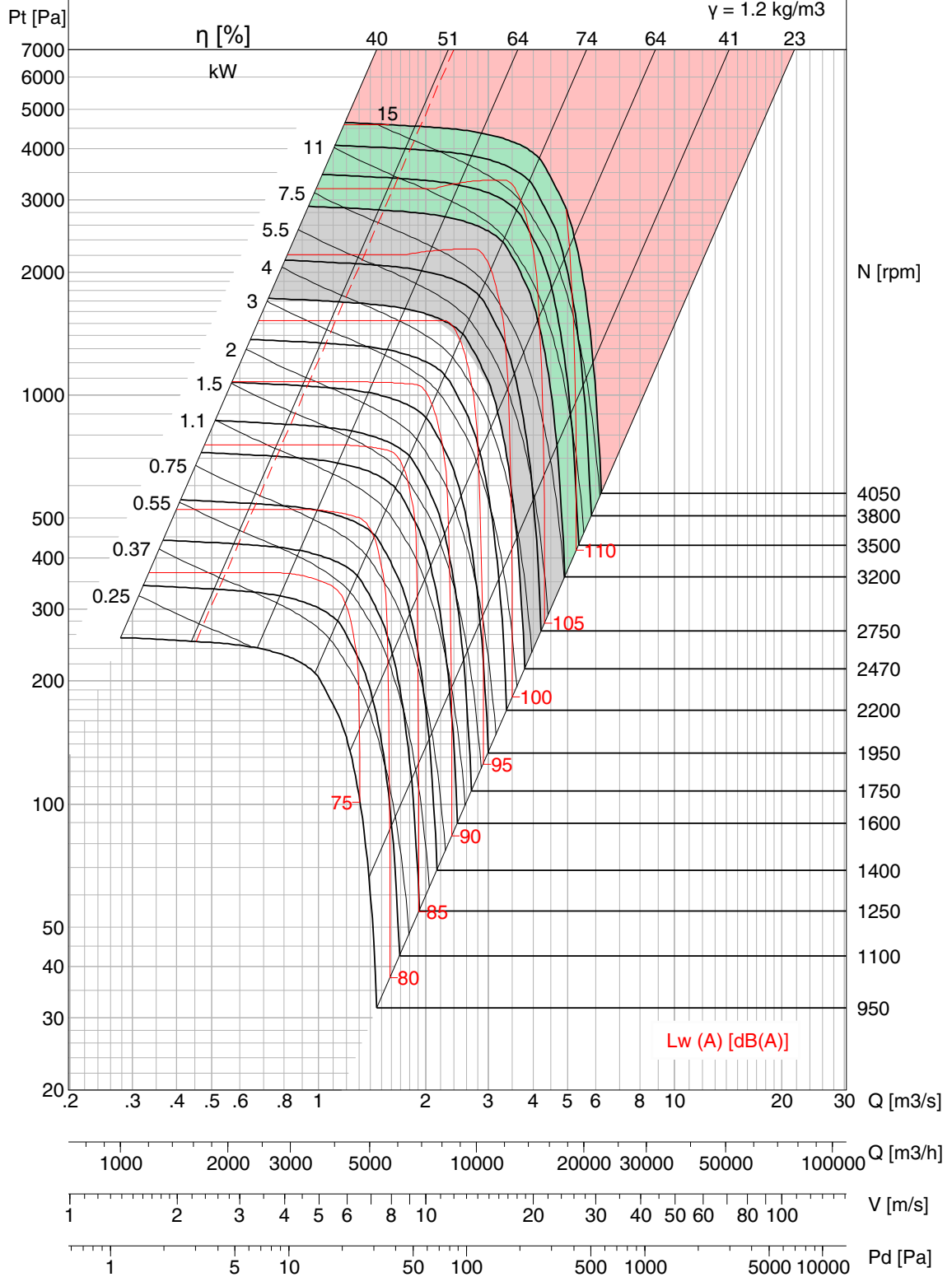

- Performance certified is for installation type A – free inlet, free outlet. Performance ratings do not include the effects of appurtenances (accessories). Power rating kW does not include transmission losses.
- Outlet Velocity of Model BNC is calculated in accordance with the fan outlet area as defined in AMCA 210 Annex H, Figure H.4.
- Values shown are for outlet Lwo A sound power levels for Installation Type A: free inlet, free outlet.
- The A-weighted sound ratings shown have been calculated per AMCA International Standard 301.
- Fan Efficiency Grade (FEG) is based on peak total efficiency in accordance with ISO 12759/ AMCA 205.
- Please consult Kruger for fan selection of class III.



BNC-Q 450

FEG 80

Op Limit	Cl. I	Cl. II	Cl. III
Type	DI	DII	DIII
M.kW	6.1	13.6	27.5
M.RPM	2600	3400	4300

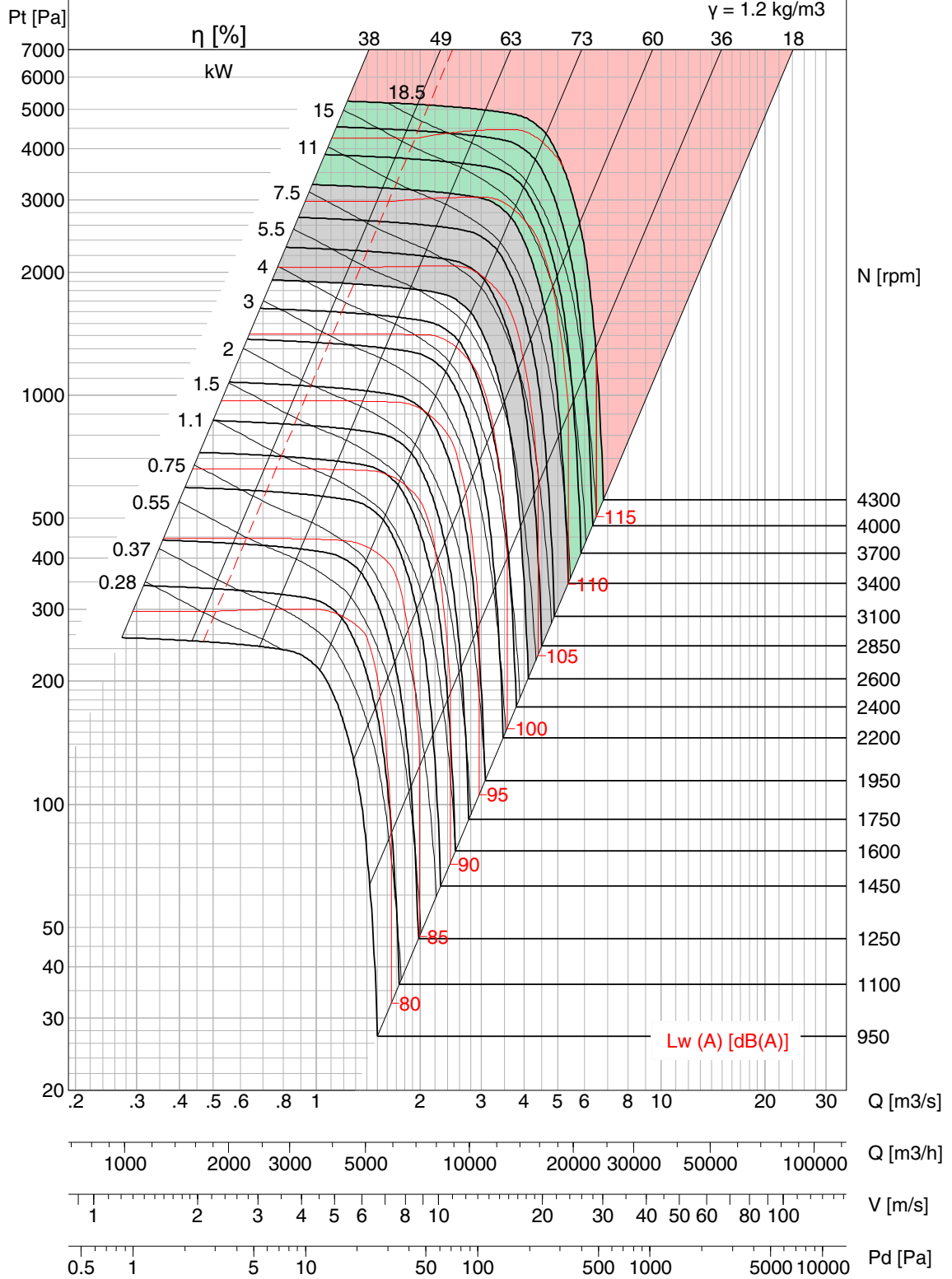

- Performance certified is for installation type A – free inlet, free outlet. Performance ratings do not include the effects of appurtenances (accessories). Power rating kW does not include transmission losses.
- Outlet Velocity of Model BNC is calculated in accordance with the fan outlet area as defined in AMCA 210 Annex H, Figure H.4.
- Values shown are for outlet Lwo A sound power levels for Installation Type A: free inlet, free outlet.
- The A-weighted sound ratings shown have been calculated per AMCA International Standard 301.
- Fan Efficiency Grade (FEG) is based on peak total efficiency in accordance with ISO 12759/ AMCA 205.
- Please consult Kruger for fan selection of class III.



BNC-P 500

FEG 80

Op Limit	Cl. I	Cl. II	Cl. III
Type	DI	DII	DIII
M.kW	5.3	11.5	23.2
M.RPM	2200	2850	3600

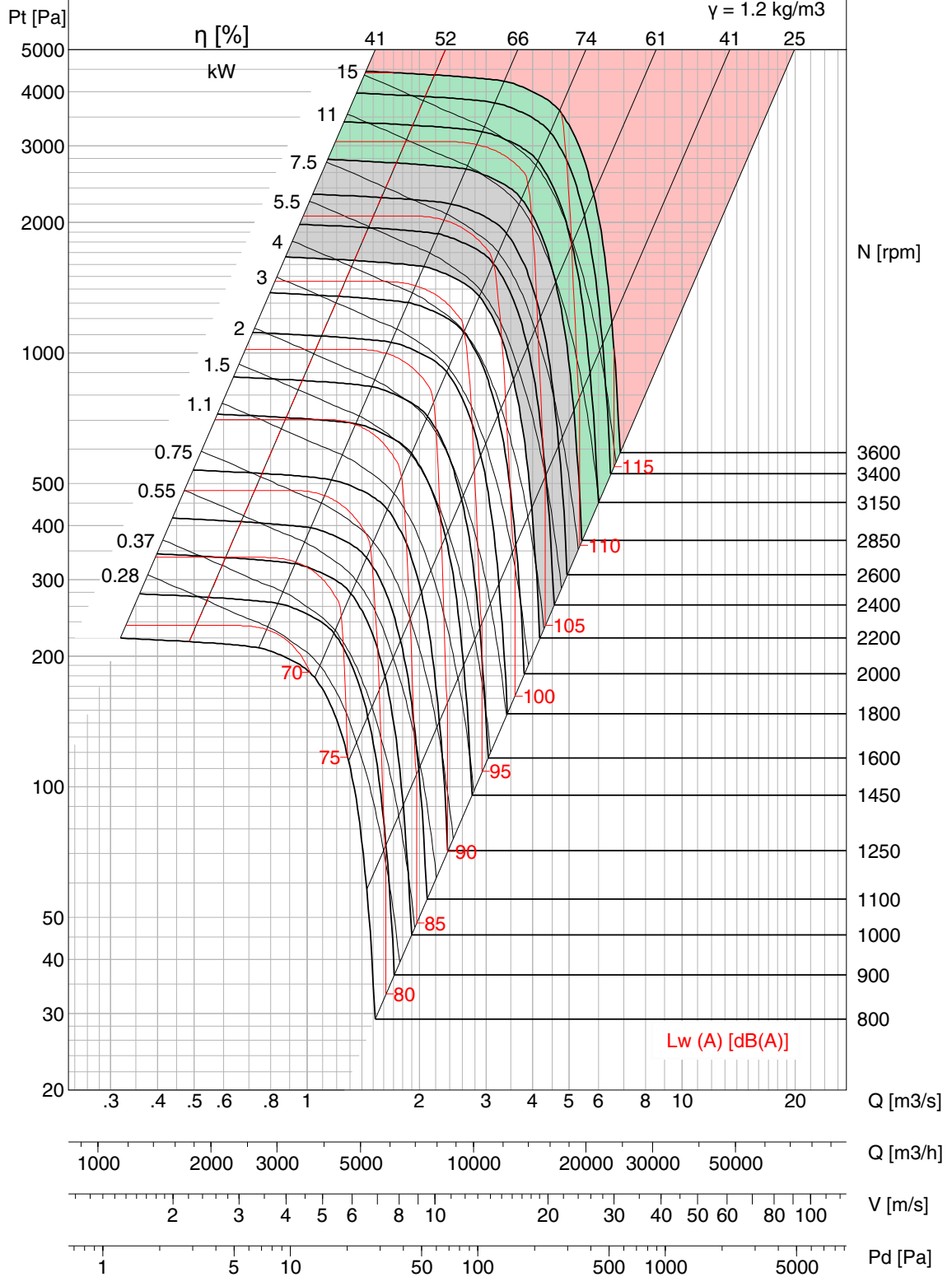

- Performance certified is for installation type A – free inlet, free outlet. Performance ratings do not include the effects of appurtenances (accessories). Power rating kW does not include transmission losses.
- Outlet Velocity of Model BNC is calculated in accordance with the fan outlet area as defined in AMCA 210 Annex H, Figure H.4.
- Values shown are for outlet Lwo A sound power levels for Installation Type A: free inlet, free outlet.
- The A-weighted sound ratings shown have been calculated per AMCA International Standard 301.
- Fan Efficiency Grade (FEG) is based on peak total efficiency in accordance with ISO 12759/ AMCA 205.
- Please consult Kruger for fan selection of class III.



BNC-R 500

FEG 80

Op Limit	Cl. I	Cl. II	Cl. III
Type	DI	DII	DIII
M.kW	6	13	27
M.RPM	2220	2880	3650

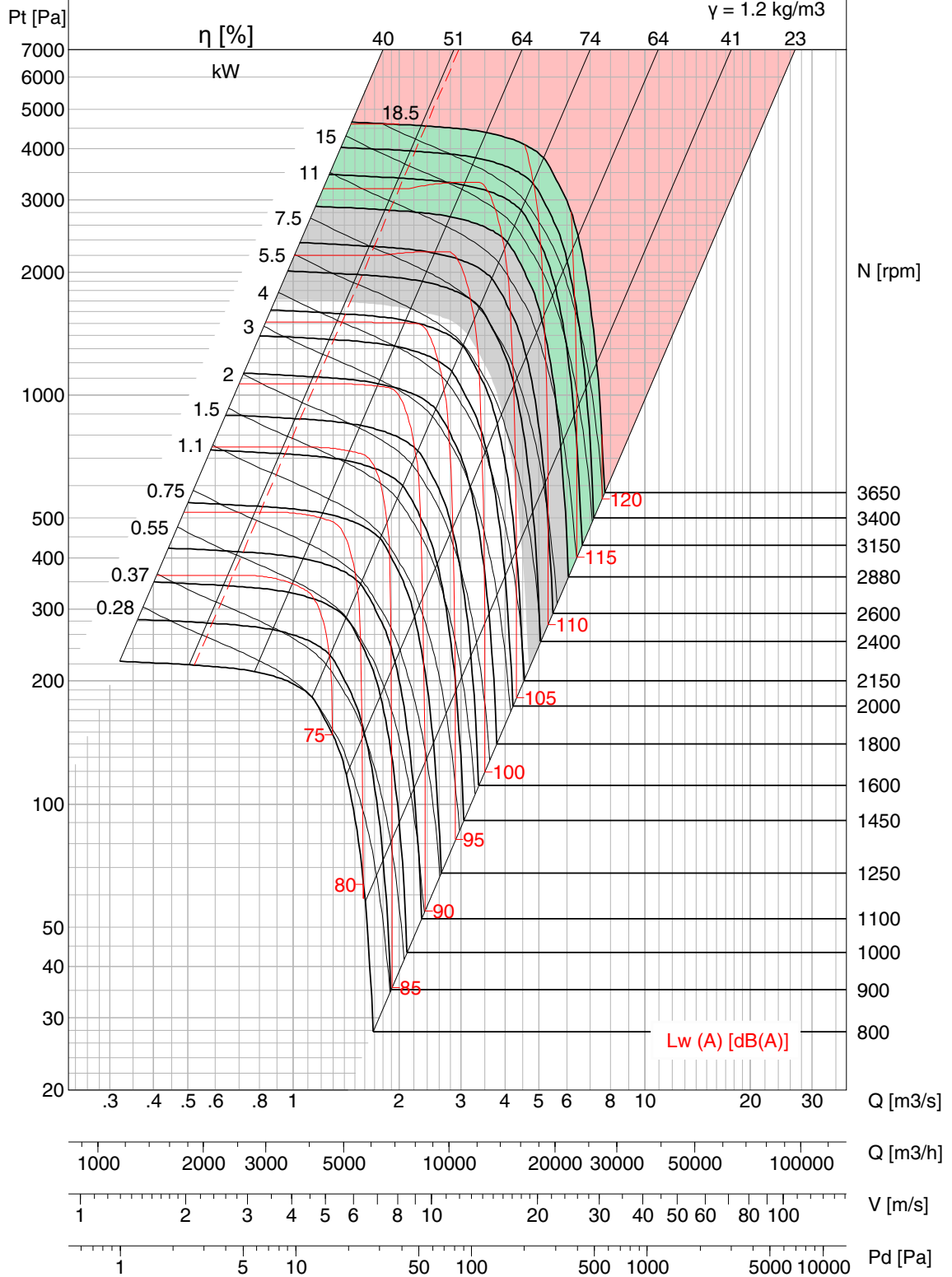

- Performance certified is for installation type A – free inlet, free outlet. Performance ratings do not include the effects of appurtenances (accessories). Power rating kW does not include transmission losses.
- Outlet Velocity of Model BNC is calculated in accordance with the fan outlet area as defined in AMCA 210 Annex H, Figure H.4.
- Values shown are for outlet Lwo A sound power levels for Installation Type A: free inlet, free outlet.
- The A-weighted sound ratings shown have been calculated per AMCA International Standard 301.
- Fan Efficiency Grade (FEG) is based on peak total efficiency in accordance with ISO 12759/ AMCA 205.
- Please consult Kruger for fan selection of class III.



BNC-Q 500

FEG 80

Op Limit	Cl. I	Cl. II	Cl. III
Type	DI	DII	DIII
M.kW	7.6	16.7	33.5
M.RPM	2350	3050	3850

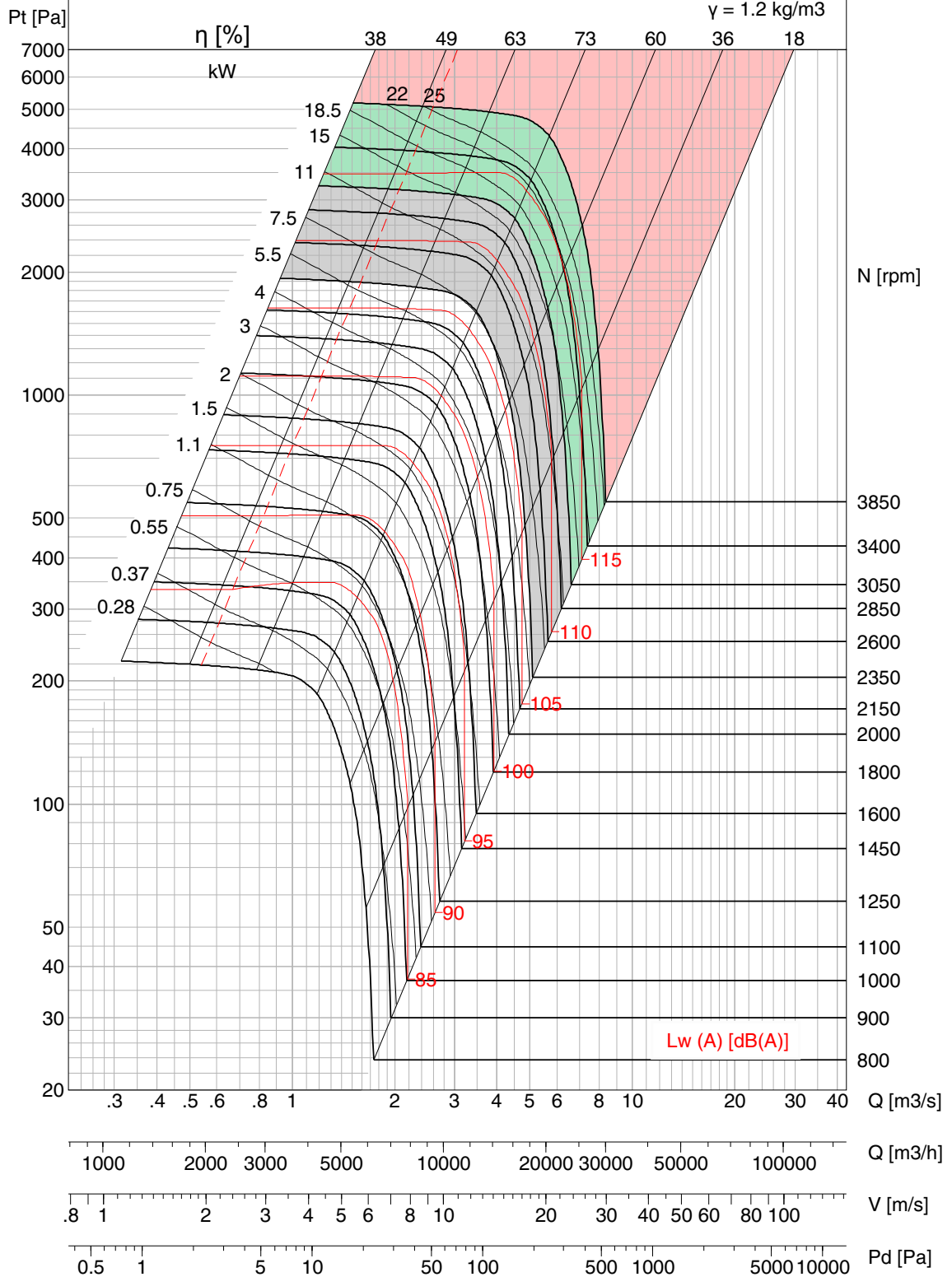

- Performance certified is for installation type A – free inlet, free outlet. Performance ratings do not include the effects of appurtenances (accessories). Power rating kW does not include transmission losses.
- Outlet Velocity of Model BNC is calculated in accordance with the fan outlet area as defined in AMCA 210 Annex H, Figure H.4.
- Values shown are for outlet Lwo A sound power levels for Installation Type A: free inlet, free outlet.
- The A-weighted sound ratings shown have been calculated per AMCA International Standard 301.
- Fan Efficiency Grade (FEG) is based on peak total efficiency in accordance with ISO 12759/ AMCA 205.
- Please consult Kruger for fan selection of class III.



BNC-P 560

FEG 80

Op Limit	Cl. I	Cl. II	Cl. III
Type	DI	DII	DIII
M.kW	6.4	13.4	26.7
M.RPM	1950	2500	3150

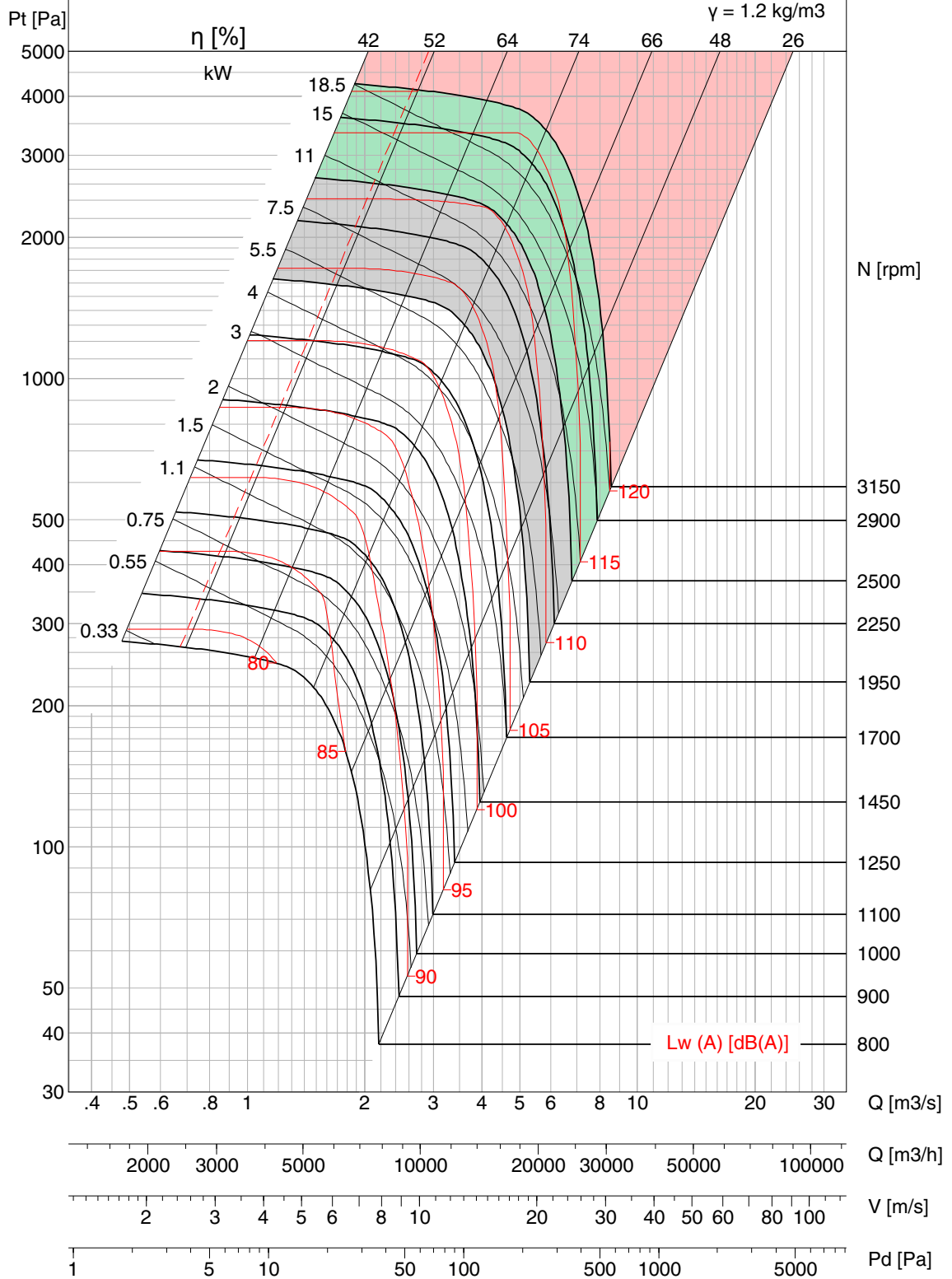

- Performance certified is for installation type A – free inlet, free outlet. Performance ratings do not include the effects of appurtenances (accessories). Power rating kW does not include transmission losses.
- Outlet Velocity of Model BNC is calculated in accordance with the fan outlet area as defined in AMCA 210 Annex H, Figure H.4.
- Values shown are for outlet Lwo A sound power levels for Installation Type A: free inlet, free outlet.
- The A-weighted sound ratings shown have been calculated per AMCA International Standard 301.
- Fan Efficiency Grade (FEG) is based on peak total efficiency in accordance with ISO 12759/ AMCA 205.
- Please consult Kruger for fan selection of class III.



BNC-R 560

FEG 80

Op Limit	Cl. I	Cl. II	Cl. III
Type	DI	DII	DIII
M.kW	7.1	15.6	31.5
M.RPM	1950	2540	3200

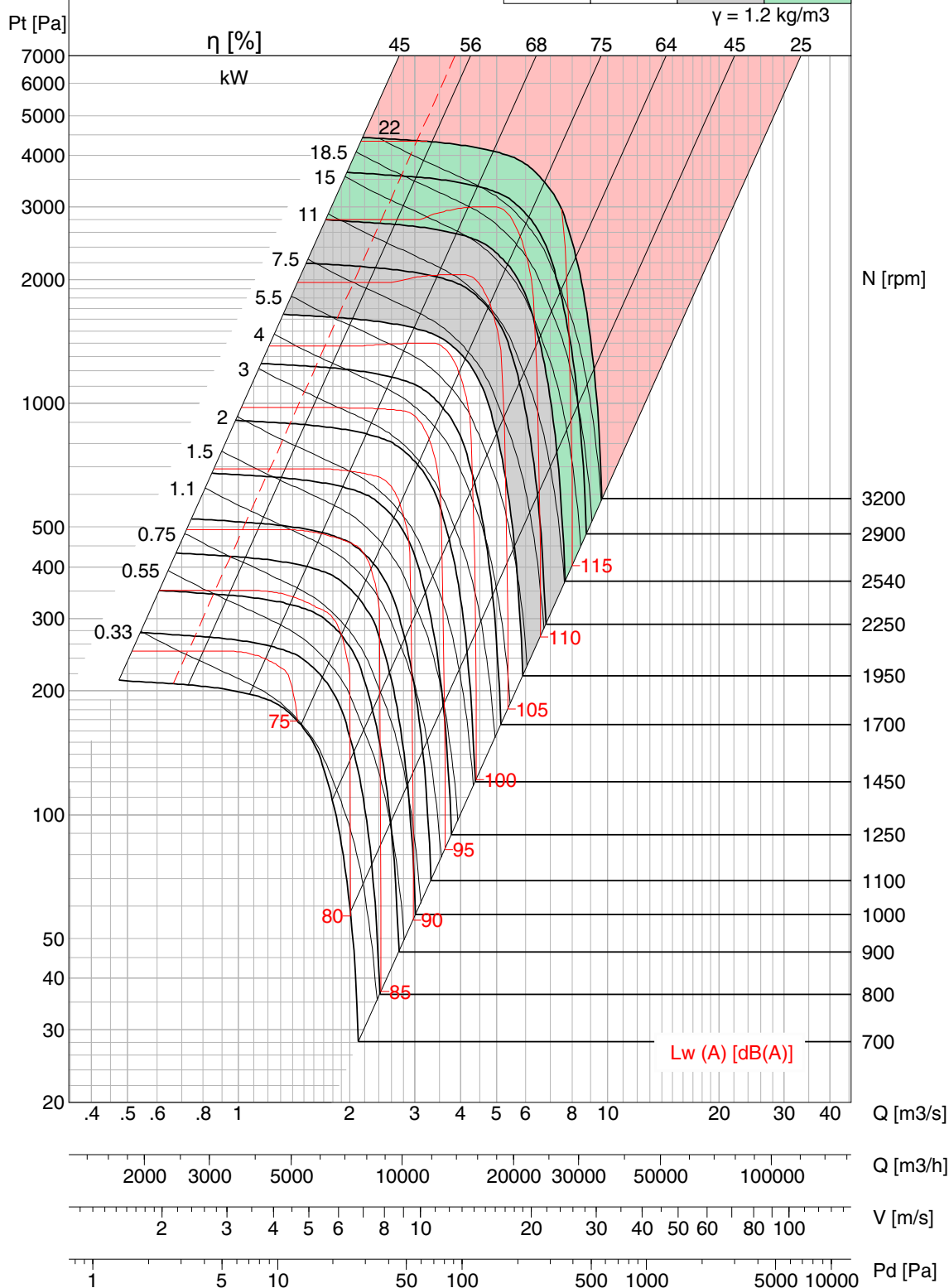

- Performance certified is for installation type A – free inlet, free outlet. Performance ratings do not include the effects of appurtenances (accessories). Power rating kW does not include transmission losses.
- Outlet Velocity of Model BNC is calculated in accordance with the fan outlet area as defined in AMCA 210 Annex H, Figure H.4.
- Values shown are for outlet Lwo A sound power levels for Installation Type A: free inlet, free outlet.
- The A-weighted sound ratings shown have been calculated per AMCA International Standard 301.
- Fan Efficiency Grade (FEG) is based on peak total efficiency in accordance with ISO 12759/ AMCA 205.
- Please consult Kruger for fan selection of class III.



BNC-Q 560

FEG 80

Op Limit	Cl. I	Cl. II	Cl. III
Type	DI	DII	DIII
M.kW	9	20.5	40.8
M.RPM	2050	2700	3400

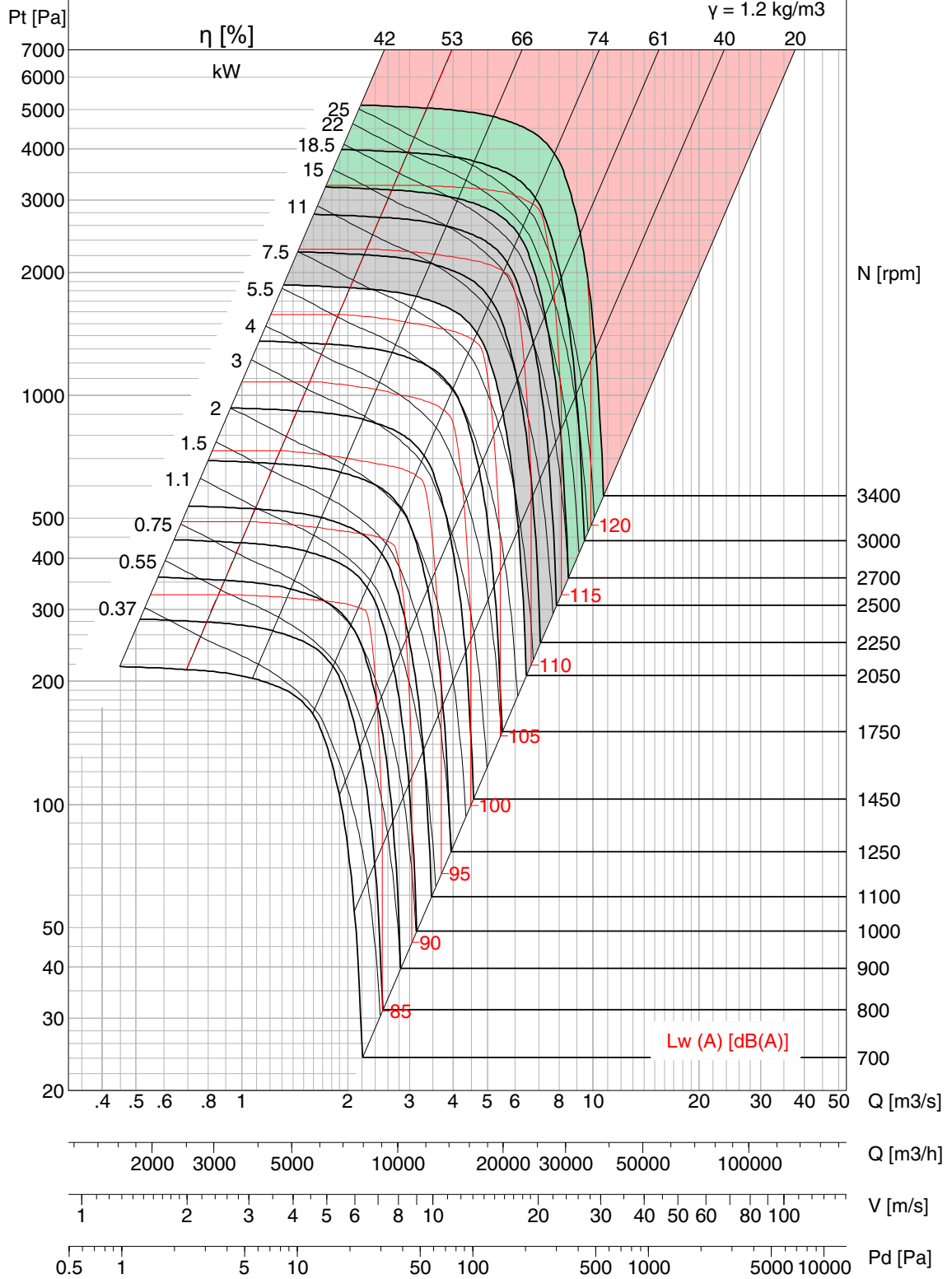

- Performance certified is for installation type A – free inlet, free outlet. Performance ratings do not include the effects of appurtenances (accessories).
- Power rating kW does not include transmission losses.
- Outlet Velocity of Model BNC is calculated in accordance with the fan outlet area as defined in AMCA 210 Annex H, Figure H.4.
- Values shown are for outlet Lwo A sound power levels for Installation Type A: free inlet, free outlet.
- The A-weighted sound ratings shown have been calculated per AMCA International Standard 301.
- Fan Efficiency Grade (FEG) is based on peak total efficiency in accordance with ISO 12759/ AMCA 205.
- Please consult Kruger for fan selection of class III.



BNC-P 630

FEG 80

Op Limit	Cl. I	Cl. II	Cl. III
Type	DI	DII	DIII
M.kW	7.4	16	33
M.RPM	1700	2200	2800

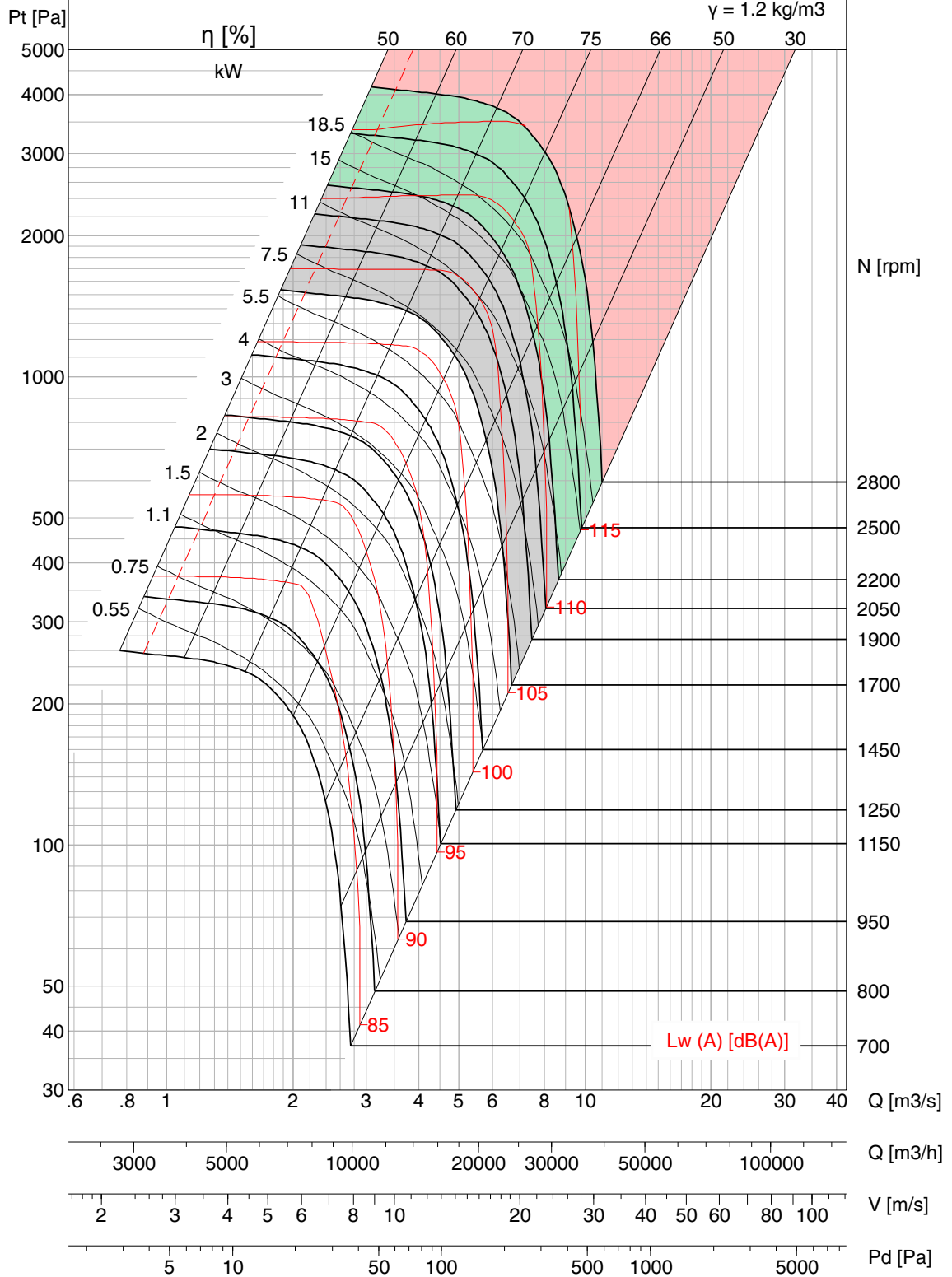

- Performance certified is for installation type A – free inlet, free outlet. Performance ratings do not include the effects of appurtenances (accessories). Power rating kW does not include transmission losses.
- Outlet Velocity of Model BNC is calculated in accordance with the fan outlet area as defined in AMCA 210 Annex H, Figure H.4.
- Values shown are for outlet Lwo A sound power levels for Installation Type A: free inlet, free outlet.
- The A-weighted sound ratings shown have been calculated per AMCA International Standard 301.
- Fan Efficiency Grade (FEG) is based on peak total efficiency in accordance with ISO 12759/ AMCA 205.
- Please consult Kruger for fan selection of class III.



BNC-R 630

FEG 80

Op Limit	Cl. I	Cl. II	Cl. III
Type	DI	DII	DIII
M.kW	9	19	38
M.RPM	1720	2230	2800

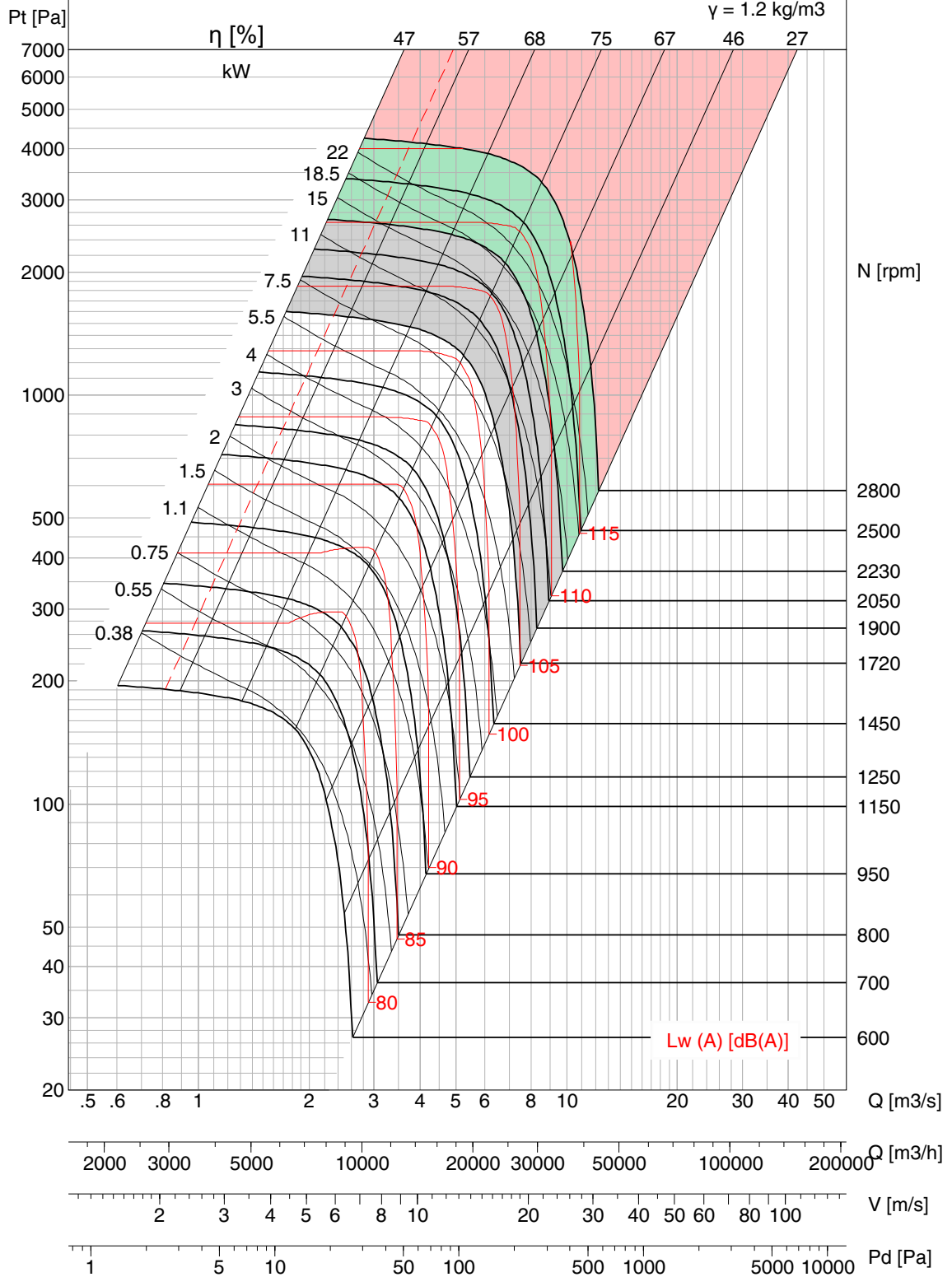

- Performance certified is for installation type A – free inlet, free outlet. Performance ratings do not include the effects of appurtenances (accessories).
- Power rating kW does not include transmission losses.
- Outlet Velocity of Model BNC is calculated in accordance with the fan outlet area as defined in AMCA 210 Annex H, Figure H.4.
- Values shown are for outlet Lwo A sound power levels for Installation Type A: free inlet, free outlet.
- The A-weighted sound ratings shown have been calculated per AMCA International Standard 301.
- Fan Efficiency Grade (FEG) is based on peak total efficiency in accordance with ISO 12759/ AMCA 205.
- Please consult Kruger for fan selection of class III.



BNC-Q 630

FEG 80

Op Limit	Cl. I	Cl. II	Cl. III
Type	DI	DII	DIII
M.kW	11	24	50
M.RPM	1800	2350	3000

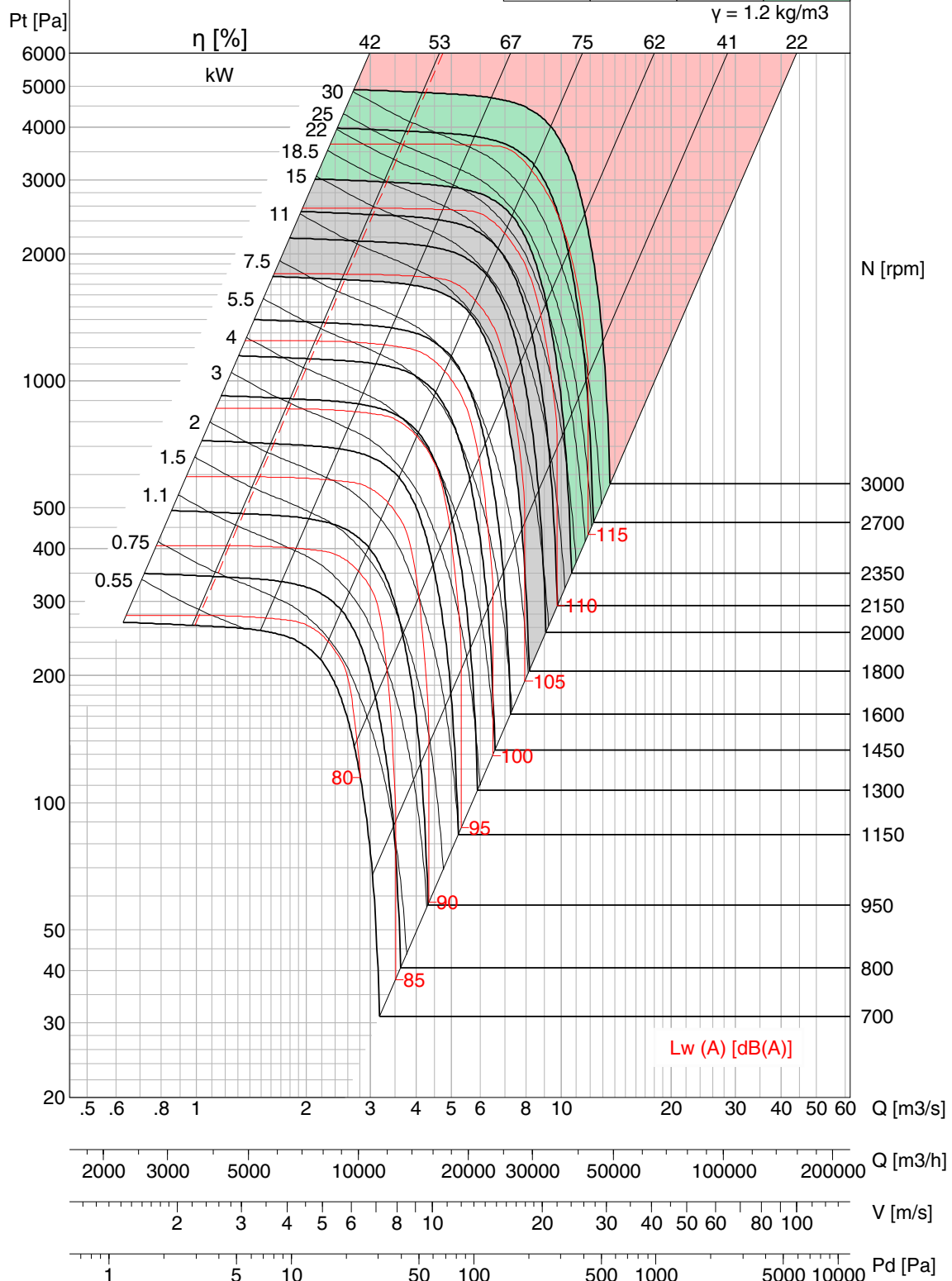

- Performance certified is for installation type A – free inlet, free outlet. Performance ratings do not include the effects of appurtenances (accessories).
- Power rating kW does not include transmission losses.
- Outlet Velocity of Model BNC is calculated in accordance with the fan outlet area as defined in AMCA 210 Annex H, Figure H.4.
- Values shown are for outlet Lwo A sound power levels for Installation Type A: free inlet, free outlet.
- The A-weighted sound ratings shown have been calculated per AMCA International Standard 301.
- Fan Efficiency Grade (FEG) is based on peak total efficiency in accordance with ISO 12759/ AMCA 205.
- Please consult Kruger for fan selection of class III.



BNC-P 710

FEG 80

Op Limit	Cl. I	Cl. II	Cl. III
Type	DI	DII	DIII
M.kW	9.7	21.3	42.3
M.RPM	1520	1980	2490

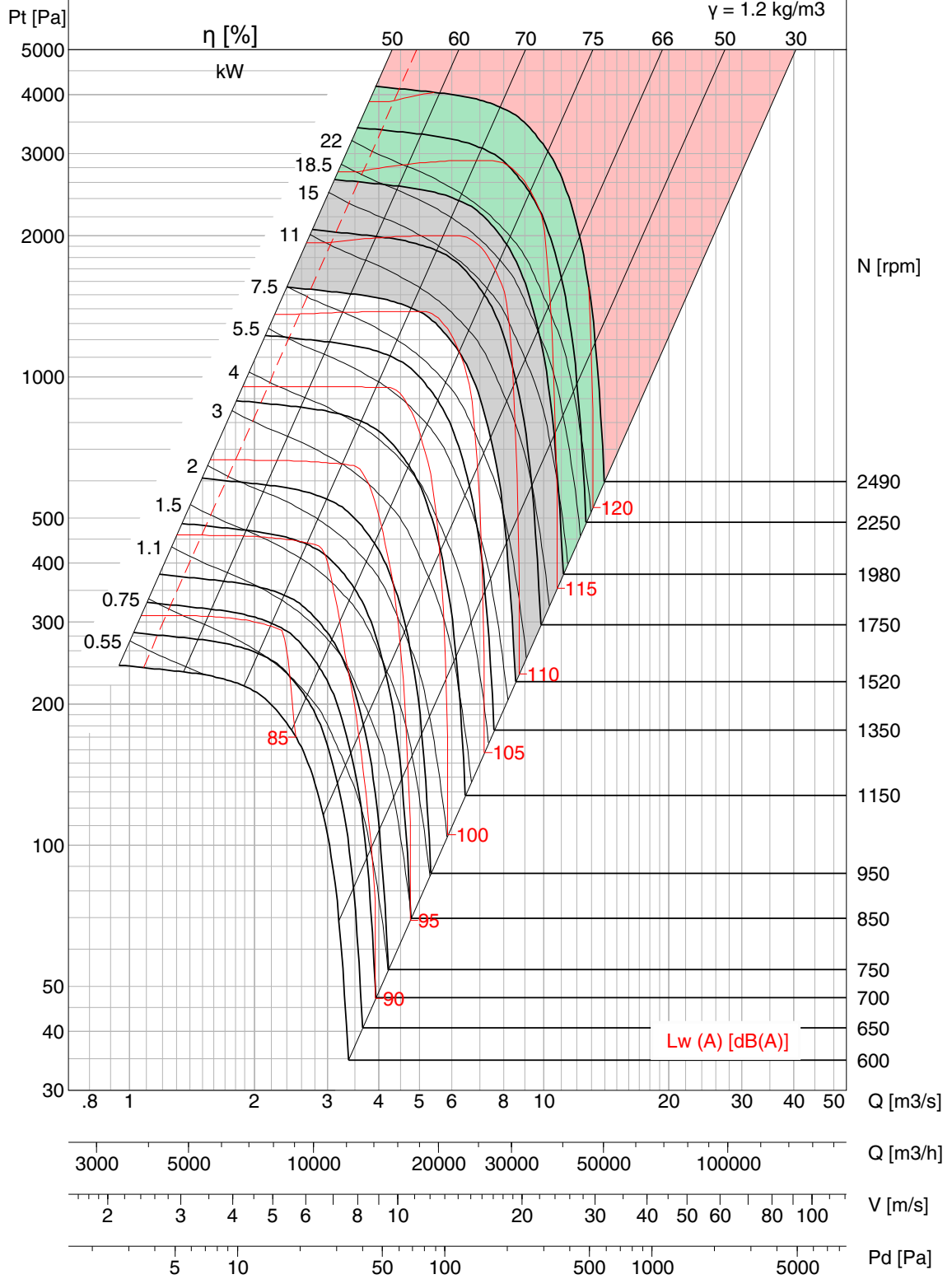

- Performance certified is for installation type A – free inlet, free outlet. Performance ratings do not include the effects of appurtenances (accessories). Power rating kW does not include transmission losses.
- Outlet Velocity of Model BNC is calculated in accordance with the fan outlet area as defined in AMCA 210 Annex H, Figure H.4.
- Values shown are for outlet Lwo A sound power levels for Installation Type A: free inlet, free outlet.
- The A-weighted sound ratings shown have been calculated per AMCA International Standard 301.
- Fan Efficiency Grade (FEG) is based on peak total efficiency in accordance with ISO 12759/ AMCA 205.
- Please consult Kruger for fan selection of class III.



BNC-R 710

FEG 80

Op Limit	Cl. I	Cl. II	Cl. III
Type	DI	DII	DIII
M.kW	11	25	49
M.RPM	1530	1990	2500

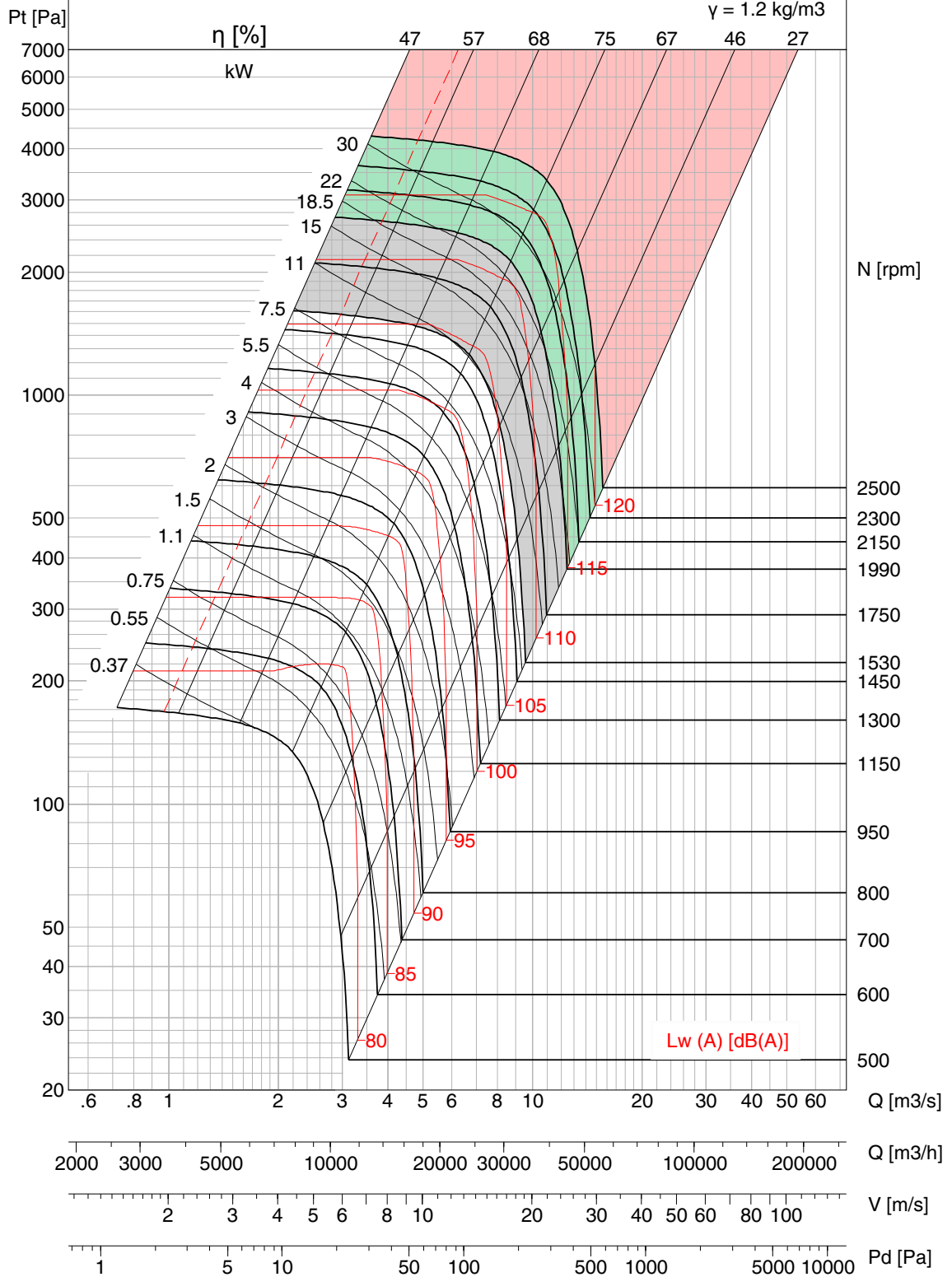

- Performance certified is for installation type A – free inlet, free outlet. Performance ratings do not include the effects of appurtenances (accessories). Power rating kW does not include transmission losses.
- Outlet Velocity of Model BNC is calculated in accordance with the fan outlet area as defined in AMCA 210 Annex H, Figure H.4.
- Values shown are for outlet Lwo A sound power levels for Installation Type A: free inlet, free outlet.
- The A-weighted sound ratings shown have been calculated per AMCA International Standard 301.
- Fan Efficiency Grade (FEG) is based on peak total efficiency in accordance with ISO 12759/ AMCA 205.
- Please consult Kruger for fan selection of class III.



BNC-Q 710

FEG 80

Op Limit	Cl. I	Cl. II	Cl. III
Type	DI	DII	DIII
M.kW	13.8	31.2	62.7
M.RPM	1600	2100	2650

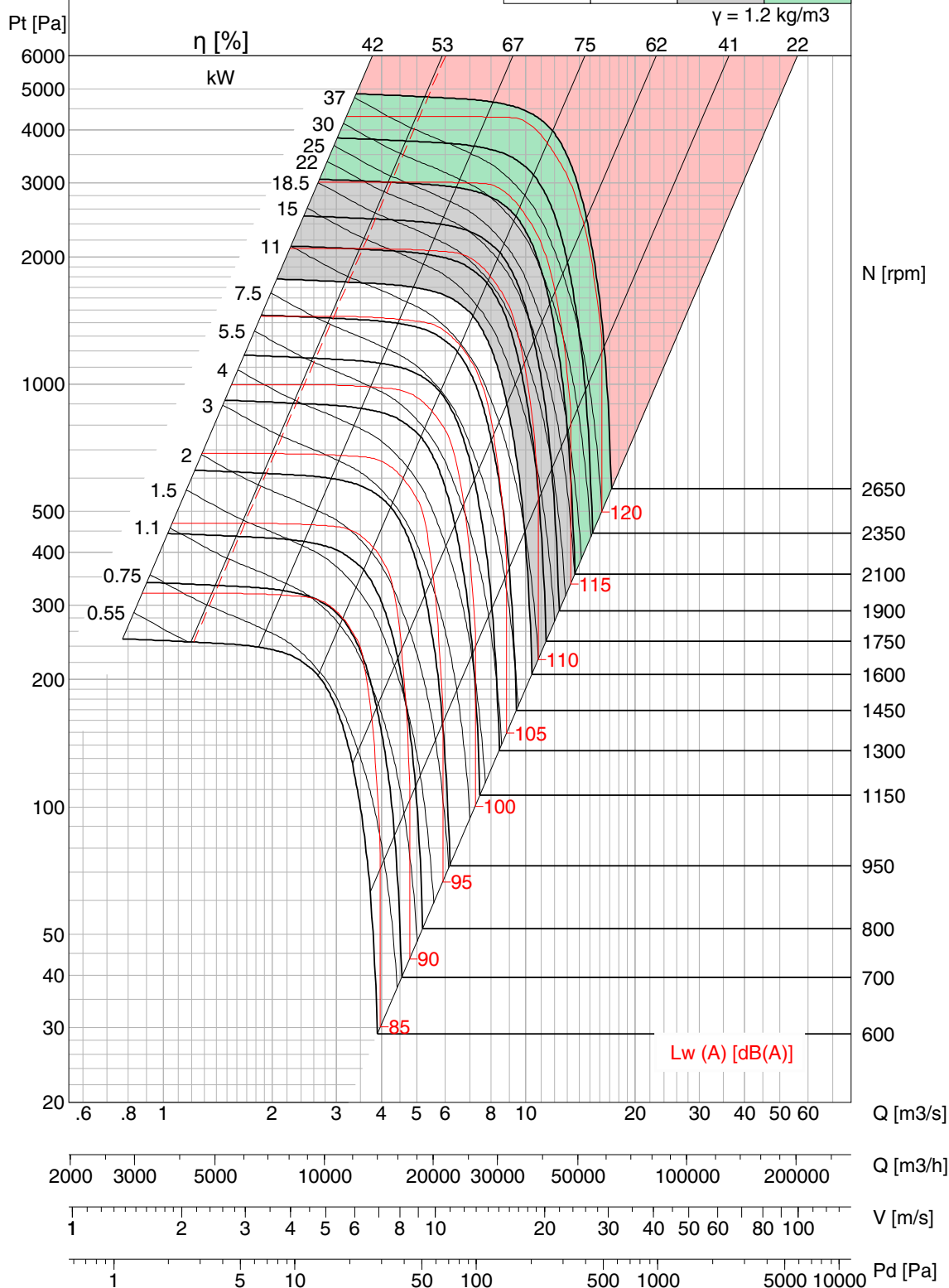

- Performance certified is for installation type A – free inlet, free outlet. Performance ratings do not include the effects of appurtenances (accessories).
- Power rating kW does not include transmission losses.
- Outlet Velocity of Model BNC is calculated in accordance with the fan outlet area as defined in AMCA 210 Annex H, Figure H.4.
- Values shown are for outlet Lwo A sound power levels for Installation Type A: free inlet, free outlet.
- The A-weighted sound ratings shown have been calculated per AMCA International Standard 301.
- Fan Efficiency Grade (FEG) is based on peak total efficiency in accordance with ISO 12759/ AMCA 205.
- Please consult Kruger for fan selection of class III.



BNC-P 800

FEG 80

Op Limit	Cl. I	Cl. II	Cl. III
Type	DI	DII	DIII
M.kW	12.3	26.7	53
M.RPM	1350	1750	2200

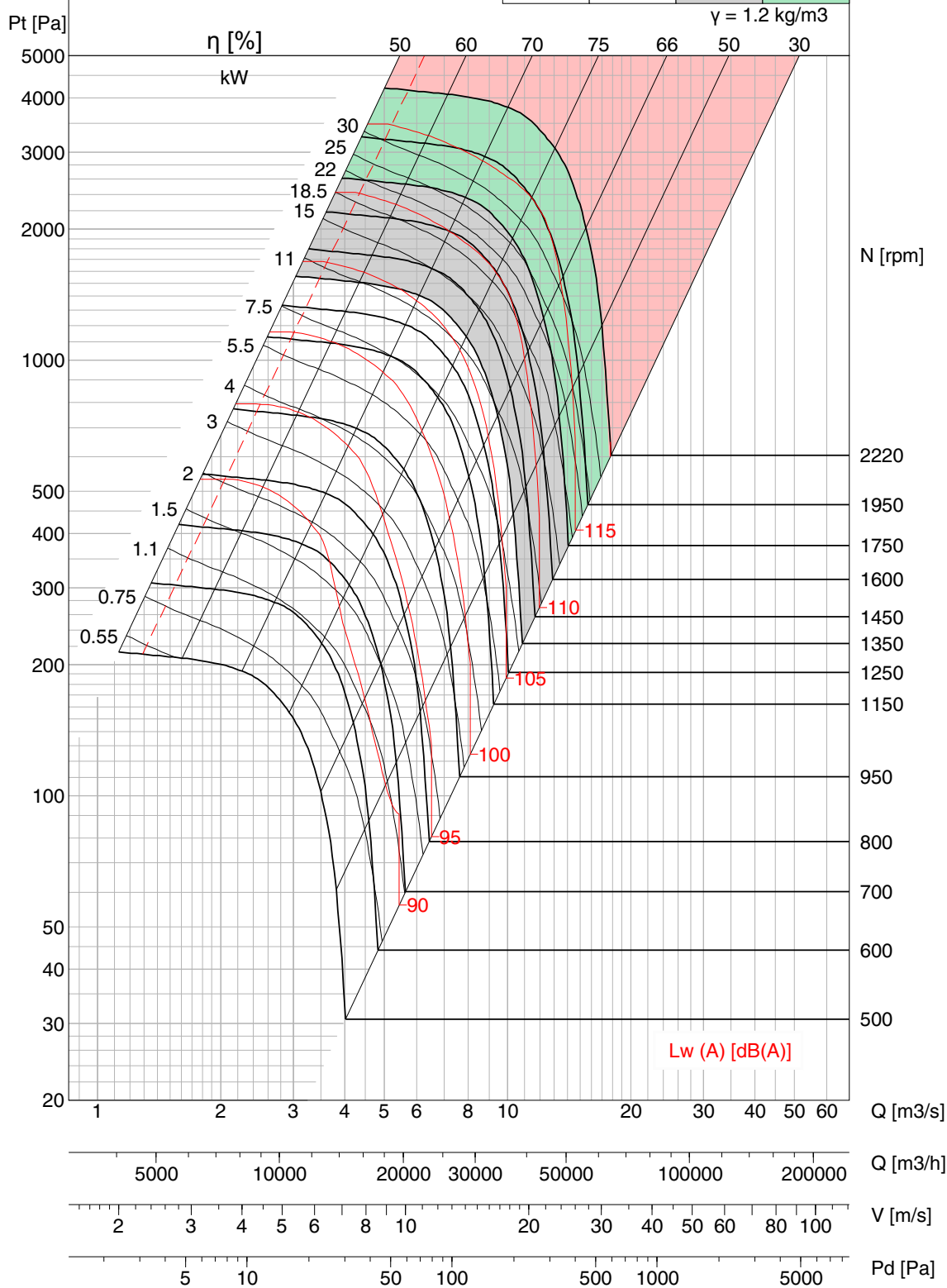

- Performance certified is for installation type A – free inlet, free outlet. Performance ratings do not include the effects of appurtenances (accessories).
- Power rating kW does not include transmission losses.
- Outlet Velocity of Model BNC is calculated in accordance with the fan outlet area as defined in AMCA 210 Annex H, Figure H.4.
- Values shown are for outlet Lwo A sound power levels for Installation Type A: free inlet, free outlet.
- The A-weighted sound ratings shown have been calculated per AMCA International Standard 301.
- Fan Efficiency Grade (FEG) is based on peak total efficiency in accordance with ISO 12759/ AMCA 205.
- Please consult Kruger for fan selection of class III.



BNC-R 800

FEG 80

Op Limit	Cl. I	Cl. II	Cl. III
Type	DI	DII	DIII
M.kW	14.6	31.5	62
M.RPM	1370	1770	2220

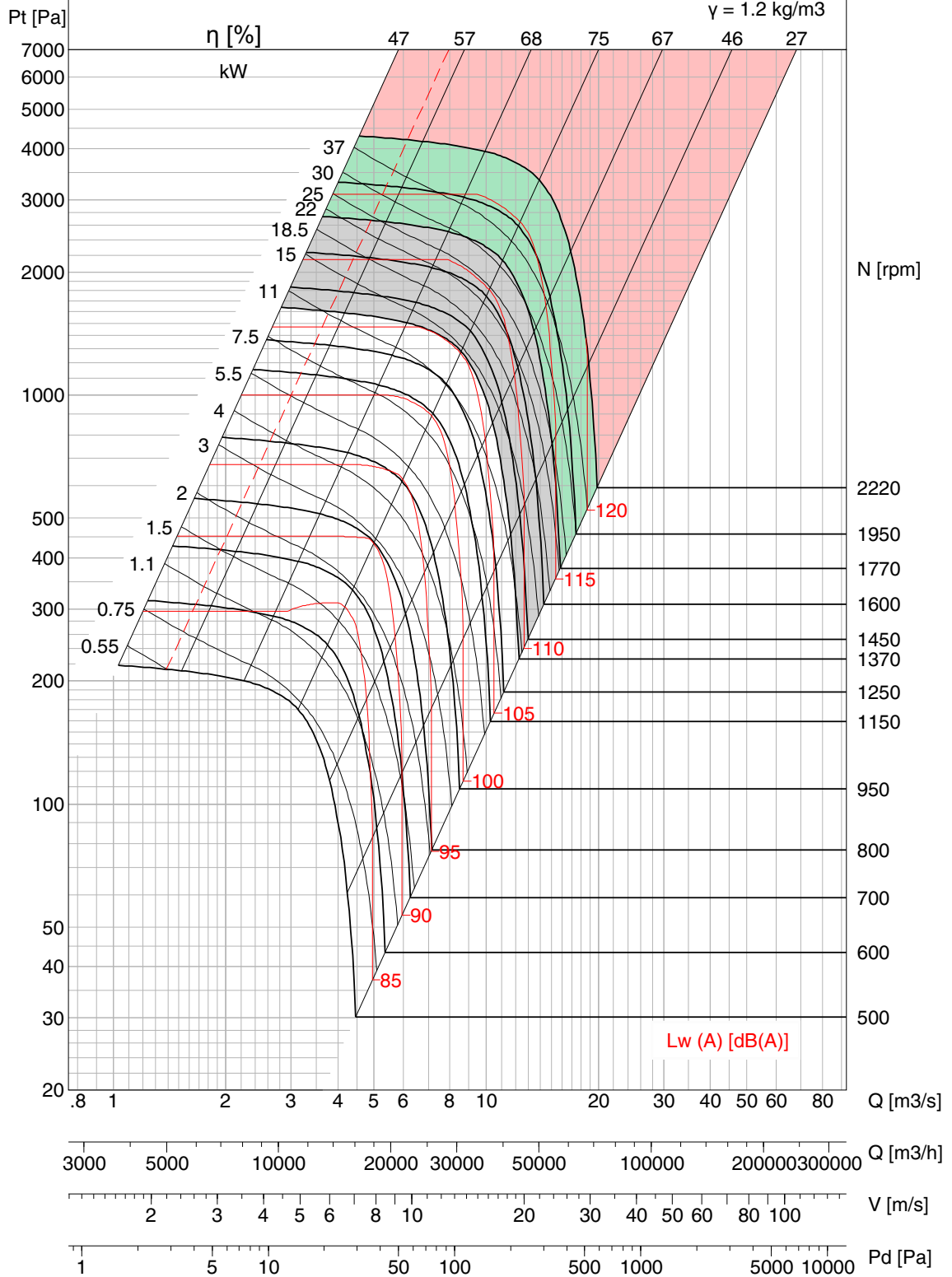

- Performance certified is for installation type A – free inlet, free outlet. Performance ratings do not include the effects of appurtenances (accessories).
- Power rating kW does not include transmission losses.
- Outlet Velocity of Model BNC is calculated in accordance with the fan outlet area as defined in AMCA 210 Annex H, Figure H.4.
- Values shown are for outlet Lwo A sound power levels for Installation Type A: free inlet, free outlet.
- The A-weighted sound ratings shown have been calculated per AMCA International Standard 301.
- Fan Efficiency Grade (FEG) is based on peak total efficiency in accordance with ISO 12759/ AMCA 205.
- Please consult Kruger for fan selection of class III.



BNC-Q 800

FEG 80

Op Limit	Cl. I	Cl. II	Cl. III
Type	DI	DII	DIII
M.kW	18.7	38.8	79.4
M.RPM	1450	1850	2350

$\gamma = 1.2 \text{ kg/m}^3$

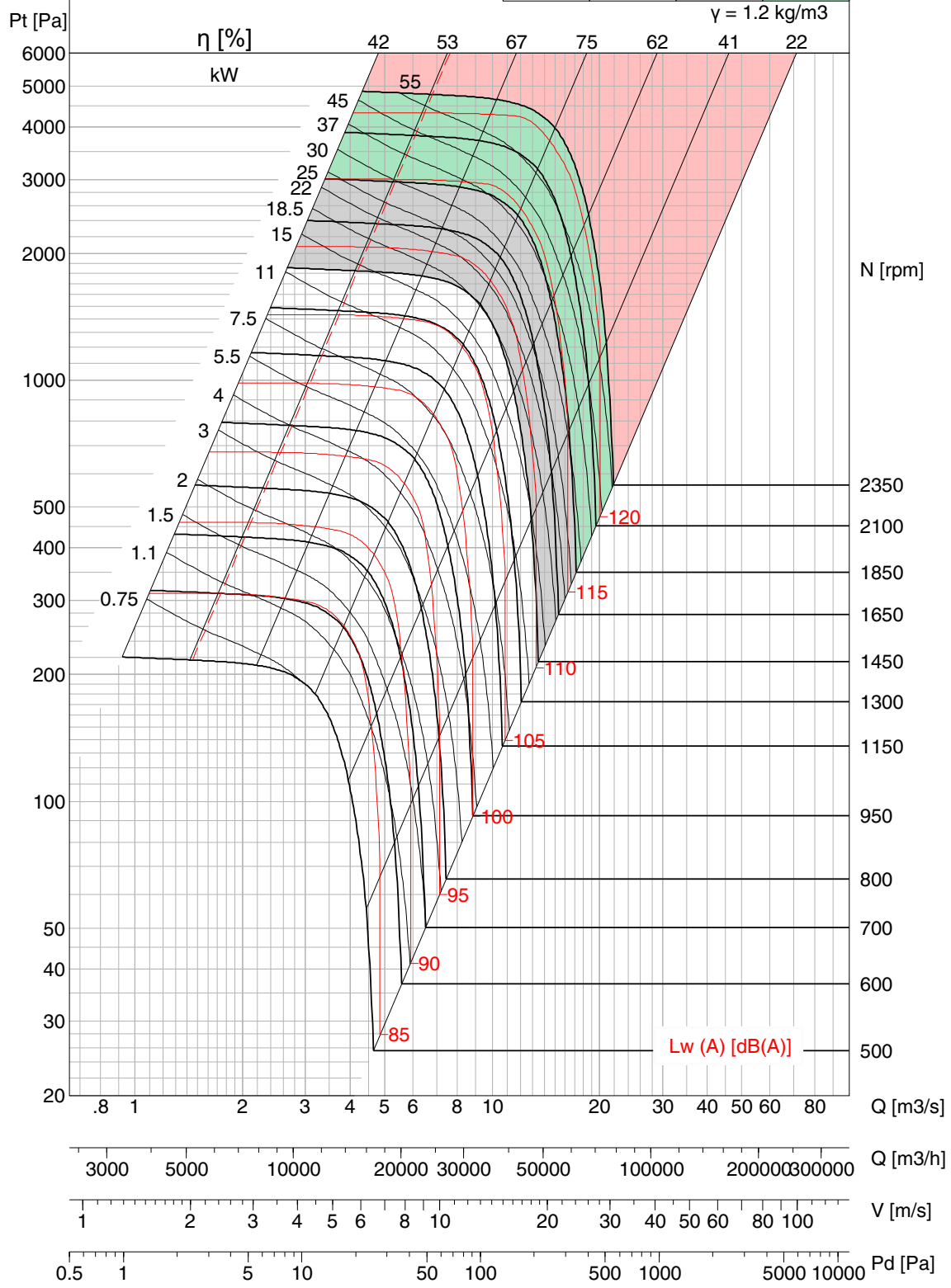

- Performance certified is for installation type A – free inlet, free outlet. Performance ratings do not include the effects of appurtenances (accessories).
- Power rating kW does not include transmission losses.
- Outlet Velocity of Model BNC is calculated in accordance with the fan outlet area as defined in AMCA 210 Annex H, Figure H.4.
- Values shown are for outlet Lwo A sound power levels for Installation Type A: free inlet, free outlet.
- The A-weighted sound ratings shown have been calculated per AMCA International Standard 301.
- Fan Efficiency Grade (FEG) is based on peak total efficiency in accordance with ISO 12759/ AMCA 205.
- Please consult Kruger for fan selection of class III.



BNC-P 900

FEG 80

Op Limit	Cl. I	Cl. II	Cl. III
Type	DI	DII	DIII
M.kW	15.3	33.5	67.4
M.RPM	1170	1520	1920

$\gamma = 1.2 \text{ kg/m}^3$

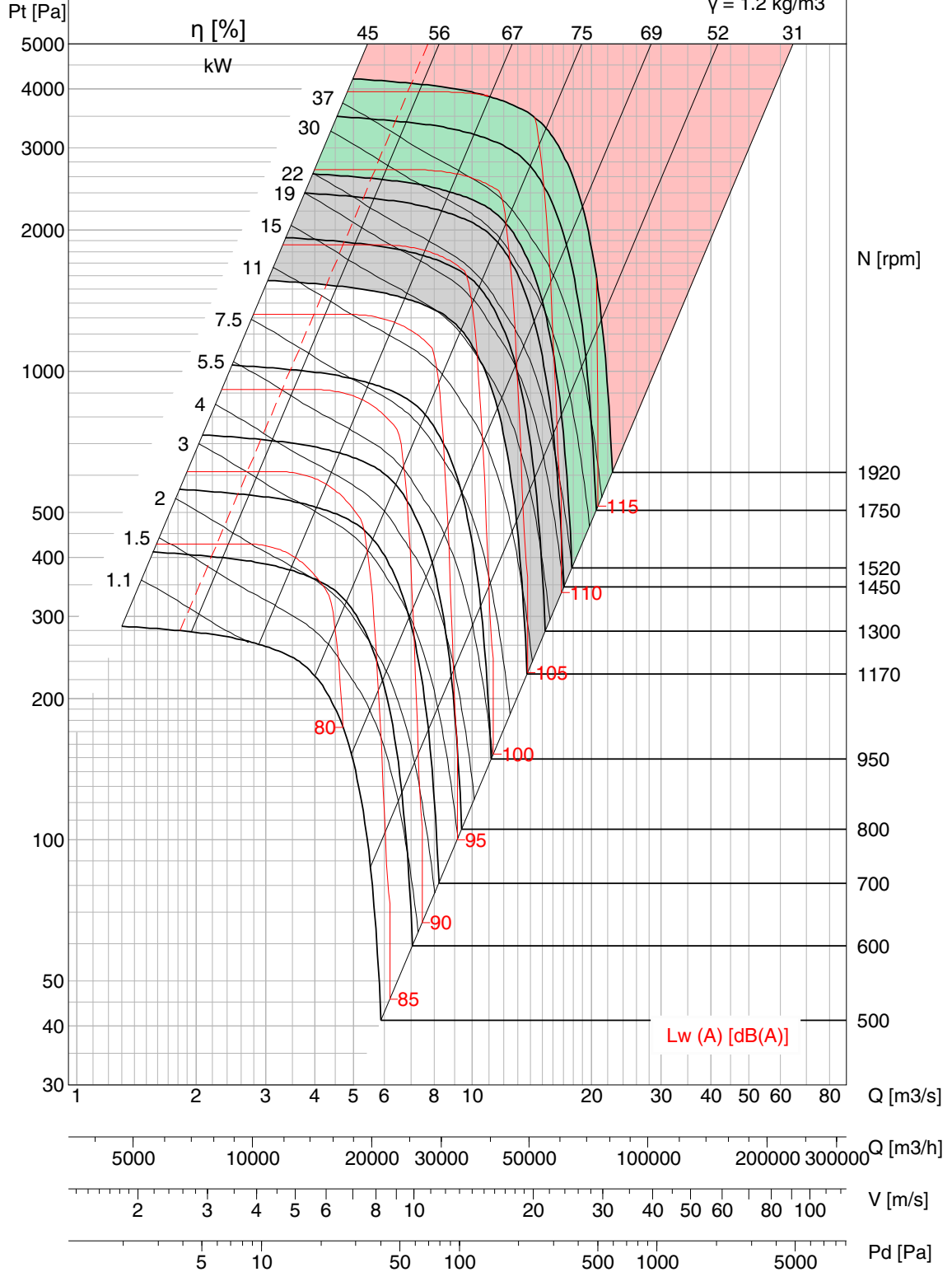

- Performance certified is for installation type A – free inlet, free outlet. Performance ratings do not include the effects of appurtenances (accessories).
- Power rating kW does not include transmission losses.
- Outlet Velocity of Model BNC is calculated in accordance with the fan outlet area as defined in AMCA 210 Annex H, Figure H.4.
- Values shown are for outlet Lwo A sound power levels for Installation Type A: free inlet, free outlet.
- The A-weighted sound ratings shown have been calculated per AMCA International Standard 301.
- Fan Efficiency Grade (FEG) is based on peak total efficiency in accordance with ISO 12759/ AMCA 205.
- Please consult Kruger for fan selection of class III.



BNC-R 900

FEG 80

Op Limit	Cl. I	Cl. II	Cl. III
Type	DI	DII	DIII
M.kW	18	39	78
M.RPM	1210	1570	1980

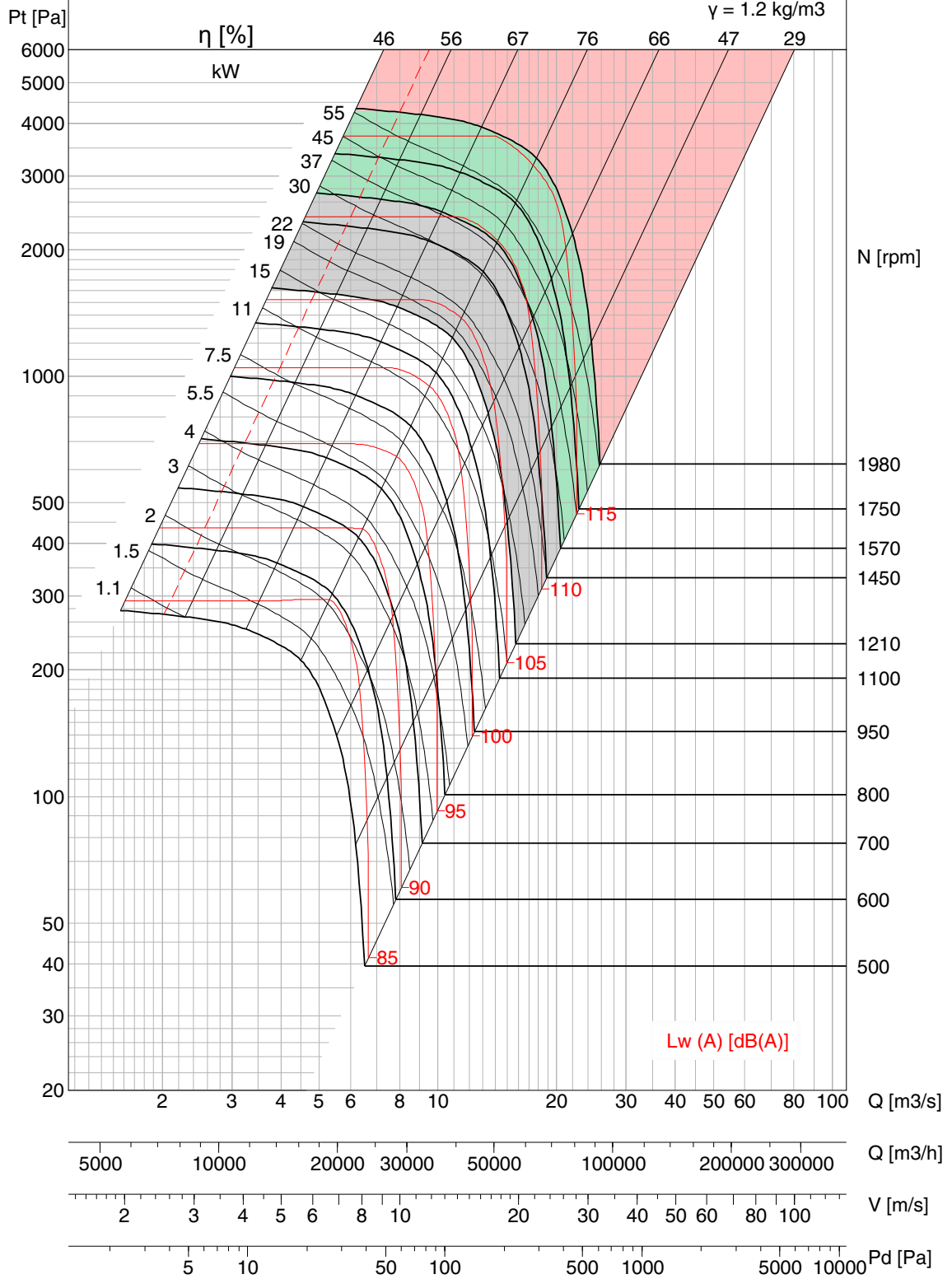

- Performance certified is for installation type A – free inlet, free outlet. Performance ratings do not include the effects of appurtenances (accessories).
- Power rating kW does not include transmission losses.
- Outlet Velocity of Model BNC is calculated in accordance with the fan outlet area as defined in AMCA 210 Annex H, Figure H.4.
- Values shown are for outlet Lwo A sound power levels for Installation Type A: free inlet, free outlet.
- The A-weighted sound ratings shown have been calculated per AMCA International Standard 301.
- Fan Efficiency Grade (FEG) is based on peak total efficiency in accordance with ISO 12759/ AMCA 205.
- Please consult Kruger for fan selection of class III.



BNC-Q 900

FEG 80

Op Limit	Cl. I	Cl. II	Cl. III
Type	DI	DII	DIII
M.kW	22.2	46.5	97.7
M.RPM	1250	1600	2050

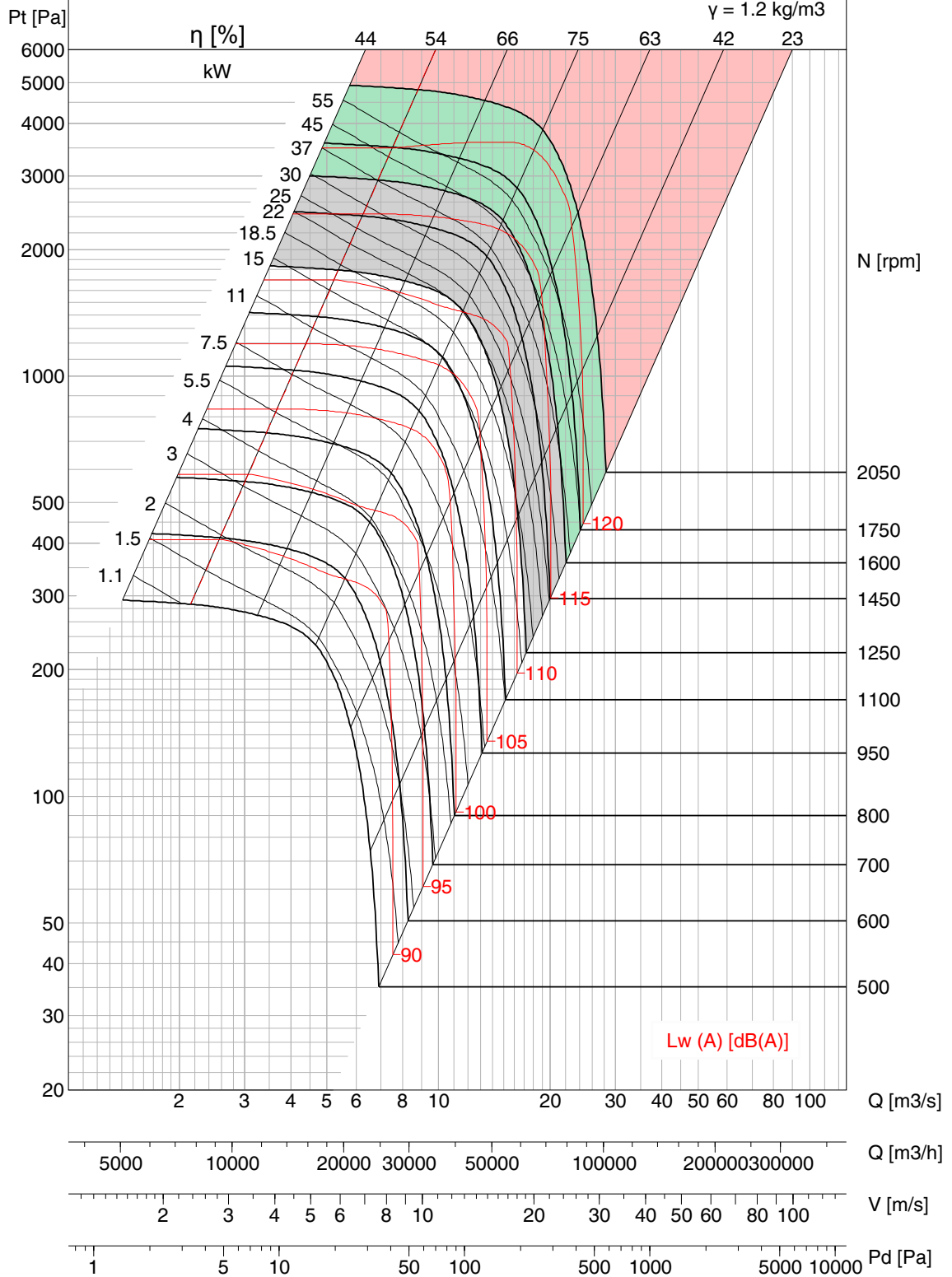

- Performance certified is for installation type A – free inlet, free outlet. Performance ratings do not include the effects of appurtenances (accessories).
- Power rating kW does not include transmission losses.
- Outlet Velocity of Model BNC is calculated in accordance with the fan outlet area as defined in AMCA 210 Annex H, Figure H.4.
- Values shown are for outlet Lwo A sound power levels for Installation Type A: free inlet, free outlet.
- The A-weighted sound ratings shown have been calculated per AMCA International Standard 301.
- Fan Efficiency Grade (FEG) is based on peak total efficiency in accordance with ISO 12759/ AMCA 205.
- Please consult Kruger for fan selection of class III.



BNC-P 1000

FEG 80

Op Limit	Cl. I	Cl. II	Cl. III
Type	DI	DII	DIII
M.kW	19.3	42.4	86.5
M.RPM	1060	1380	1750

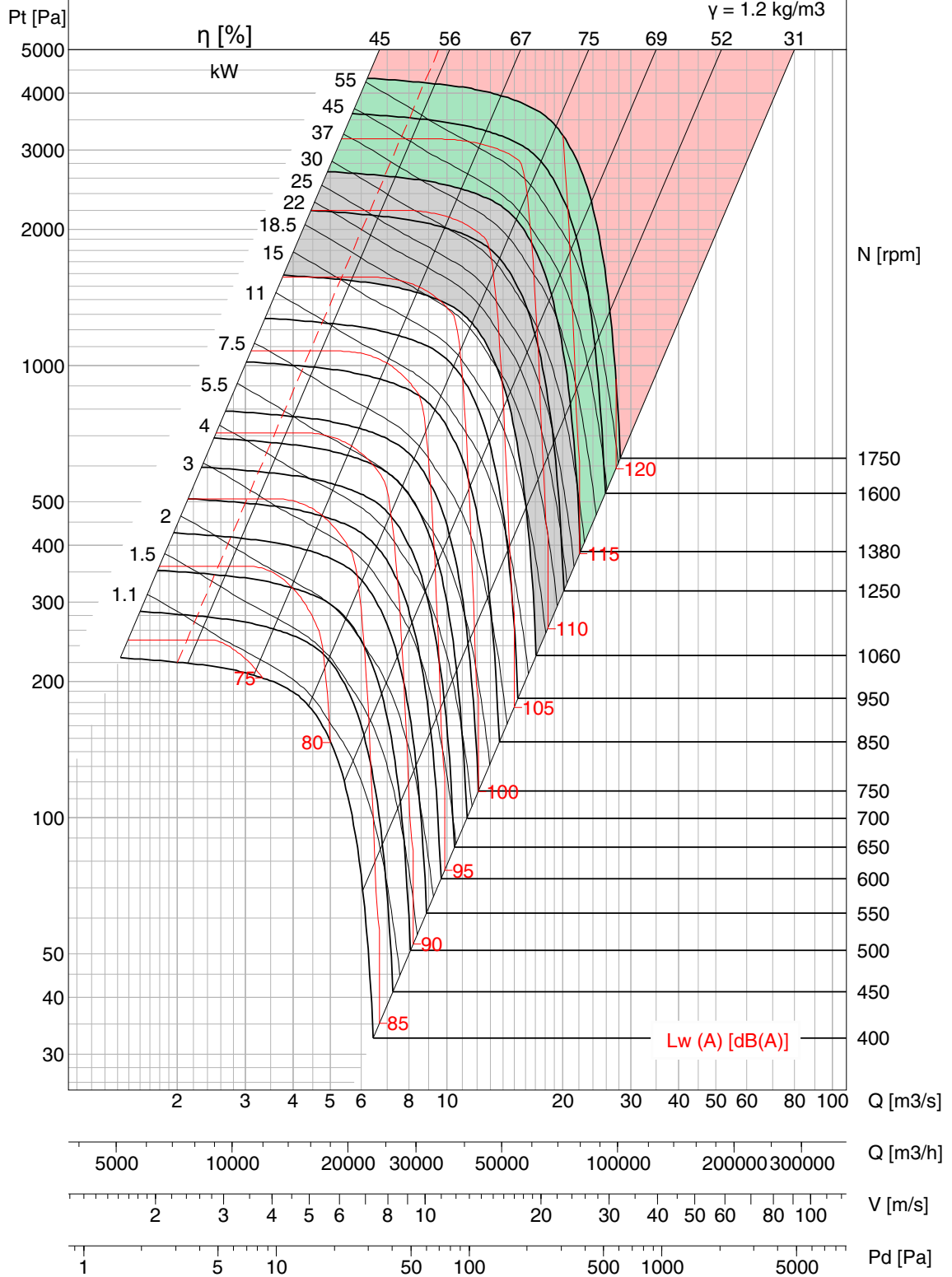

- Performance certified is for installation type A – free inlet, free outlet. Performance ratings do not include the effects of appurtenances (accessories). Power rating kW does not include transmission losses.
- Outlet Velocity of Model BNC is calculated in accordance with the fan outlet area as defined in AMCA 210 Annex H, Figure H.4.
- Values shown are for outlet Lwo A sound power levels for Installation Type A: free inlet, free outlet.
- The A-weighted sound ratings shown have been calculated per AMCA International Standard 301.
- Fan Efficiency Grade (FEG) is based on peak total efficiency in accordance with ISO 12759/ AMCA 205.
- Please consult Kruger for fan selection of class III.



BNC-R 1000

FEG 80

Op Limit	Cl. I	Cl. II	Cl. III
Type	DI	DII	DIII
M.kW	21.4	47	94
M.RPM	1080	1400	1770

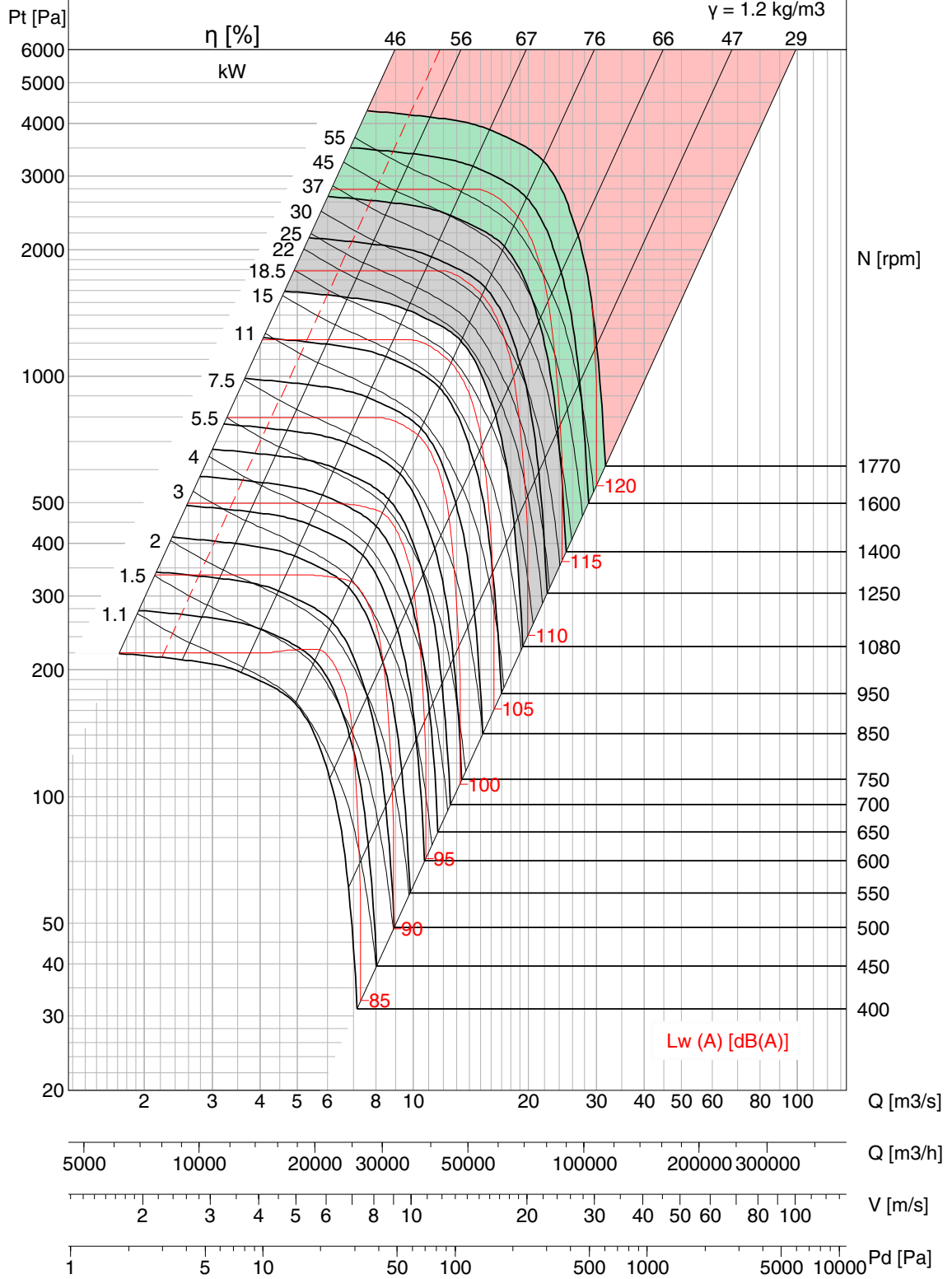

- Performance certified is for installation type A – free inlet, free outlet. Performance ratings do not include the effects of appurtenances (accessories).
- Power rating kW does not include transmission losses.
- Outlet Velocity of Model BNC is calculated in accordance with the fan outlet area as defined in AMCA 210 Annex H, Figure H.4.
- Values shown are for outlet Lwo A sound power levels for Installation Type A: free inlet, free outlet.
- The A-weighted sound ratings shown have been calculated per AMCA International Standard 301.
- Fan Efficiency Grade (FEG) is based on peak total efficiency in accordance with ISO 12759/ AMCA 205.
- Please consult Kruger for fan selection of class III.



BNC-Q 1000

FEG 80

Op Limit	Cl. I	Cl. II	Cl. III
Type	DI	DII	DIII
M.kW	27	59	122
M.RPM	1120	1450	1850

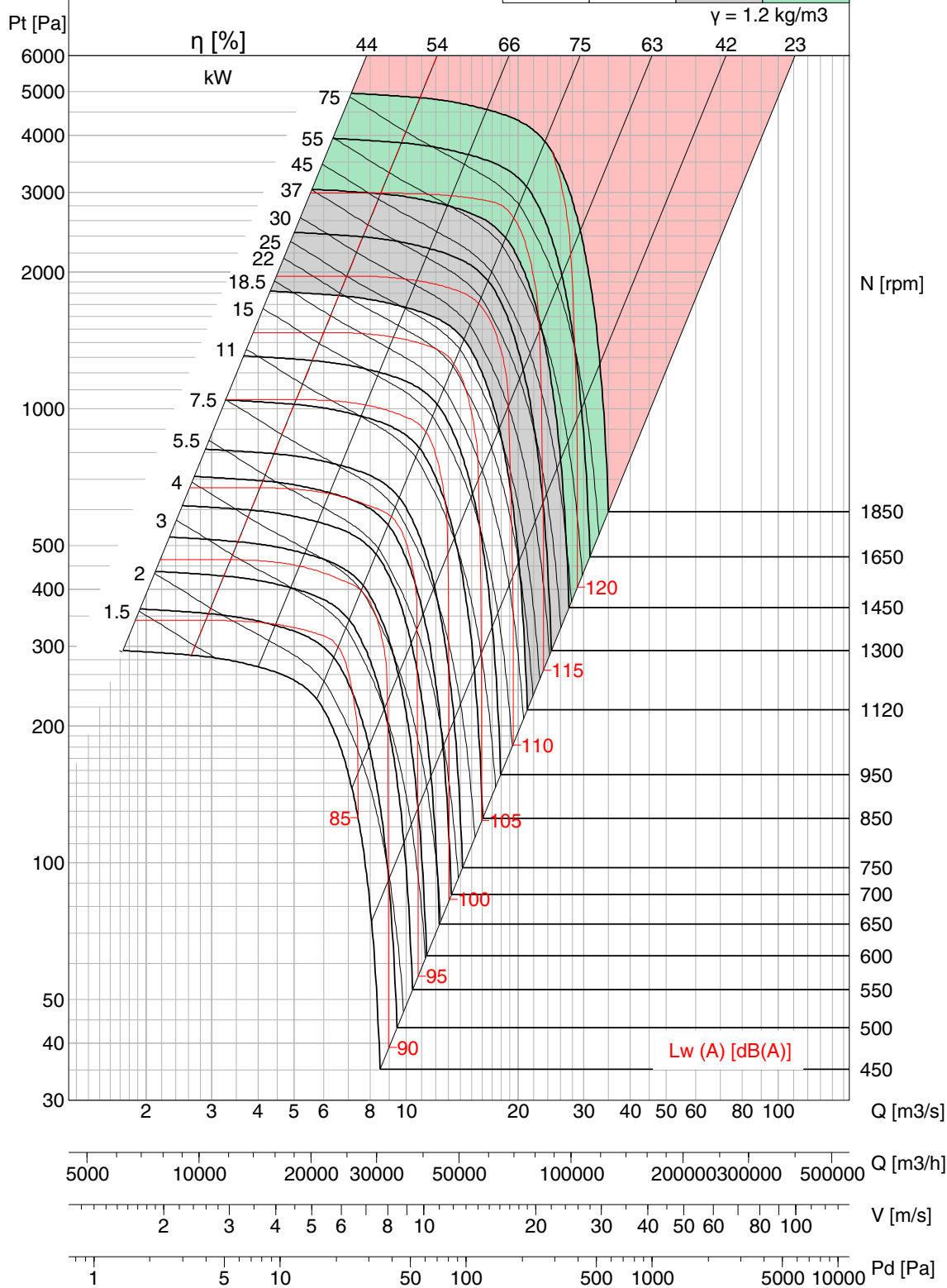

- Performance certified is for installation type A – free inlet, free outlet. Performance ratings do not include the effects of appurtenances (accessories). Power rating kW does not include transmission losses.
- Outlet Velocity of Model BNC is calculated in accordance with the fan outlet area as defined in AMCA 210 Annex H, Figure H.4.
- Values shown are for outlet Lwo A sound power levels for Installation Type A: free inlet, free outlet.
- The A-weighted sound ratings shown have been calculated per AMCA International Standard 301.
- Fan Efficiency Grade (FEG) is based on peak total efficiency in accordance with ISO 12759/ AMCA 205.
- Please consult Kruger for fan selection of class III.



BNC-P 1120

FEG 80

Op Limit	Cl. I	Cl. II	Cl. III
Type	DI	DII	DIII
M.kW	24.5	53	106
M.RPM	950	1230	1550

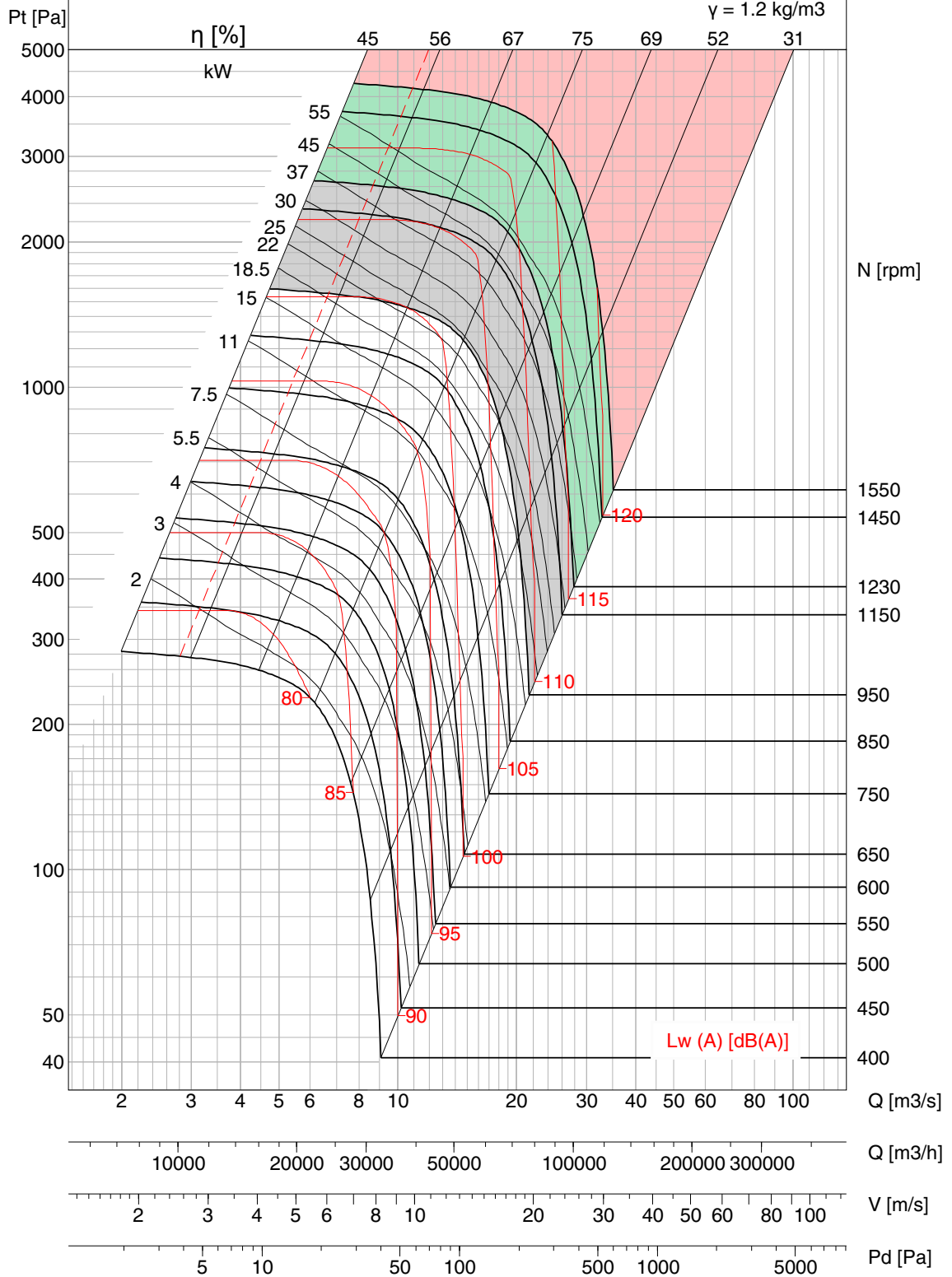

- Performance certified is for installation type A – free inlet, free outlet. Performance ratings do not include the effects of appurtenances (accessories). Power rating kW does not include transmission losses.
- Outlet Velocity of Model BNC is calculated in accordance with the fan outlet area as defined in AMCA 210 Annex H, Figure H.4.
- Values shown are for outlet Lwo A sound power levels for Installation Type A: free inlet, free outlet.
- The A-weighted sound ratings shown have been calculated per AMCA International Standard 301.
- Fan Efficiency Grade (FEG) is based on peak total efficiency in accordance with ISO 12759/ AMCA 205.
- Please consult Kruger for fan selection of class III.



BNC-R 1120

FEG 80

Op Limit	Cl. I	Cl. II	Cl. III
Type	DI	DII	DIII
M.kW	27.5	58.5	118
M.RPM	970	1250	1580

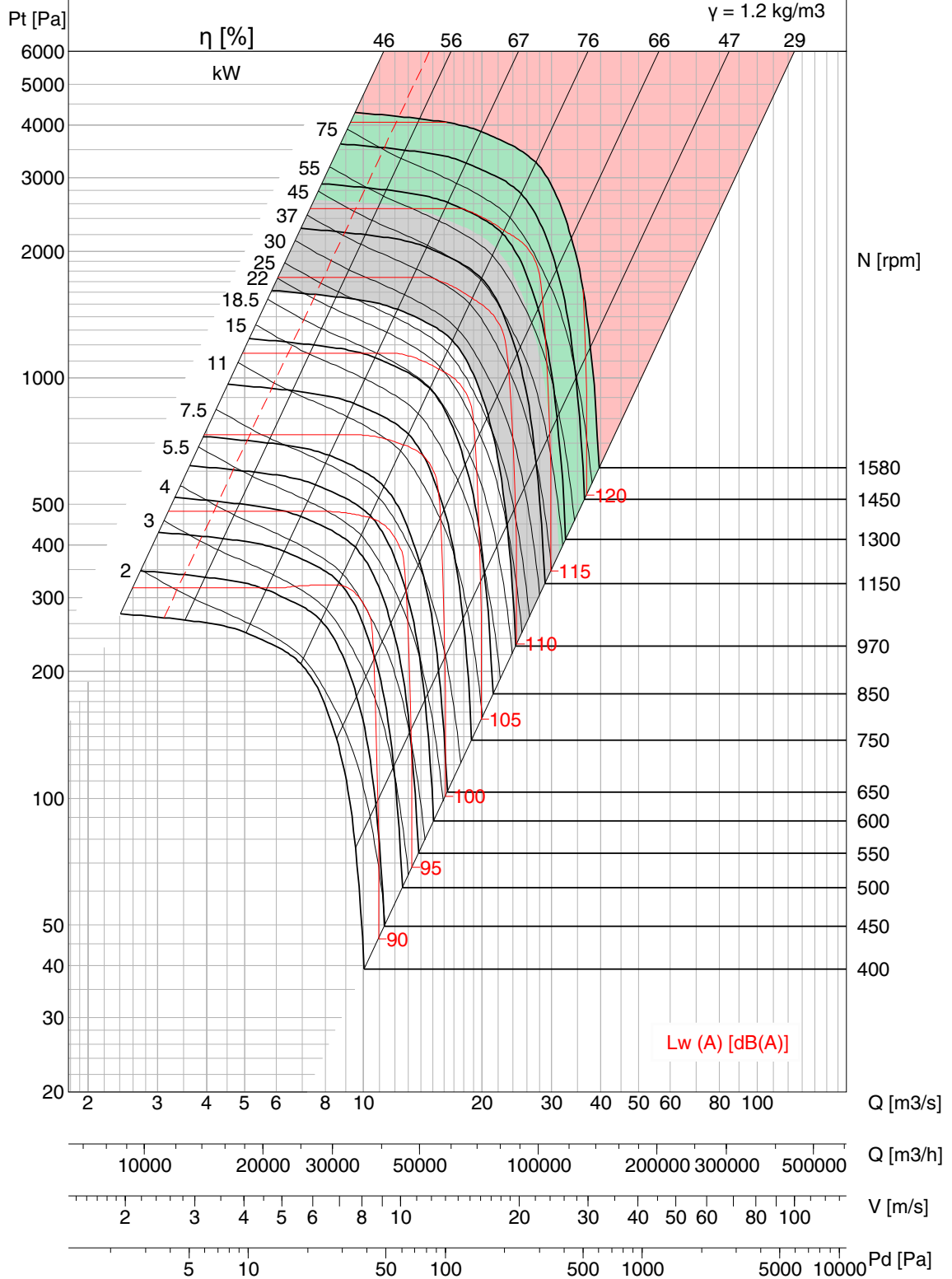

- Performance certified is for installation type A – free inlet, free outlet. Performance ratings do not include the effects of appurtenances (accessories).
- Power rating kW does not include transmission losses.
- Outlet Velocity of Model BNC is calculated in accordance with the fan outlet area as defined in AMCA 210 Annex H, Figure H.4.
- Values shown are for outlet Lwo A sound power levels for Installation Type A: free inlet, free outlet.
- The A-weighted sound ratings shown have been calculated per AMCA International Standard 301.
- Fan Efficiency Grade (FEG) is based on peak total efficiency in accordance with ISO 12759/ AMCA 205.
- Please consult Kruger for fan selection of class III.



BNC-Q 1120

FEG 80

Op Limit	Cl. I	Cl. II	Cl. III
Type	DI	DII	DIII
M.kW	34	74.5	152
M.RPM	1000	1300	1650

$\gamma = 1.2 \text{ kg/m}^3$

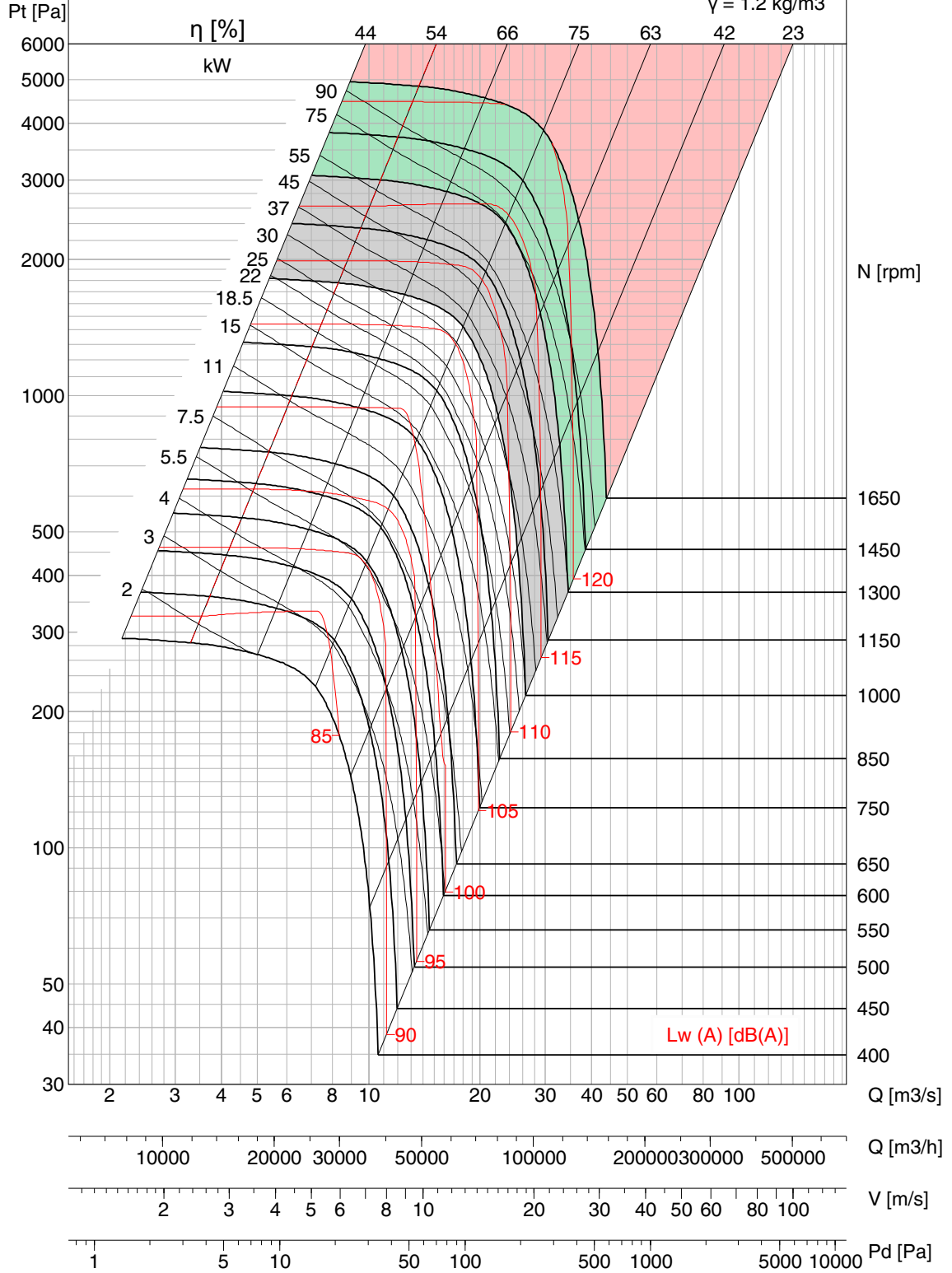

- Performance certified is for installation type A – free inlet, free outlet. Performance ratings do not include the effects of appurtenances (accessories). Power rating kW does not include transmission losses.
- Outlet Velocity of Model BNC is calculated in accordance with the fan outlet area as defined in AMCA 210 Annex H, Figure H.4.
- Values shown are for outlet Lwo A sound power levels for Installation Type A: free inlet, free outlet.
- The A-weighted sound ratings shown have been calculated per AMCA International Standard 301.
- Fan Efficiency Grade (FEG) is based on peak total efficiency in accordance with ISO 12759/ AMCA 205.
- Please consult Kruger for fan selection of class III.



BNC-P 1250

FEG 80

Op Limit	Cl. I	Cl. II	Cl. III
Type	DI	DII	DIII
M.kW	30.3	65.5	135
M.RPM	850	1100	1400

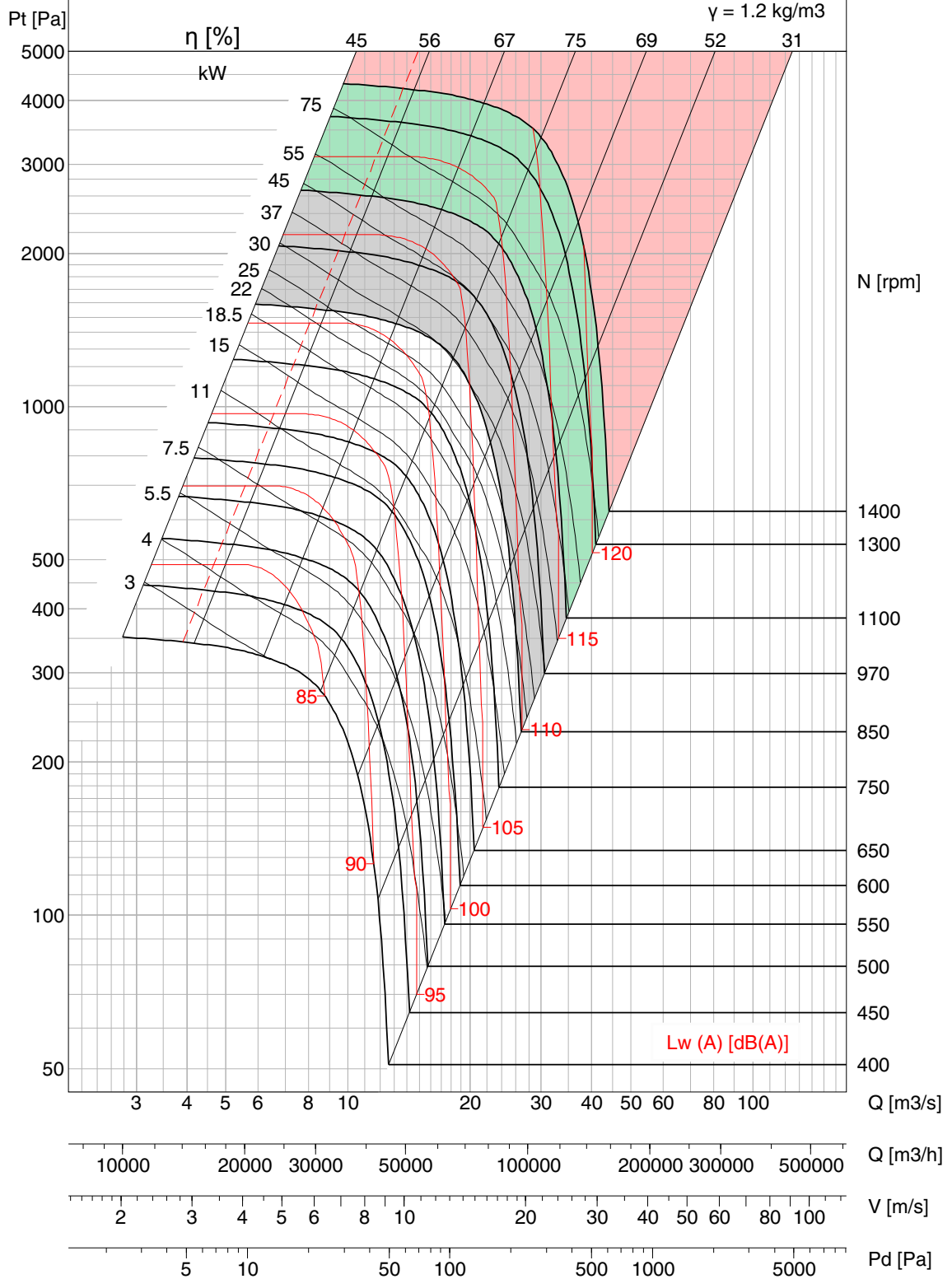

- Performance certified is for installation type A – free inlet, free outlet. Performance ratings do not include the effects of appurtenances (accessories). Power rating kW does not include transmission losses.
- Outlet Velocity of Model BNC is calculated in accordance with the fan outlet area as defined in AMCA 210 Annex H, Figure H.4.
- Values shown are for outlet Lwo A sound power levels for Installation Type A: free inlet, free outlet.
- The A-weighted sound ratings shown have been calculated per AMCA International Standard 301.
- Fan Efficiency Grade (FEG) is based on peak total efficiency in accordance with ISO 12759/ AMCA 205.
- Please consult Kruger for fan selection of class III.



BNC-R 1250

FEG 80

Op Limit	Cl. I	Cl. II	Cl. III
Type	DI	DII	DIII
M.kW	34	75	145
M.RPM	870	1130	1420

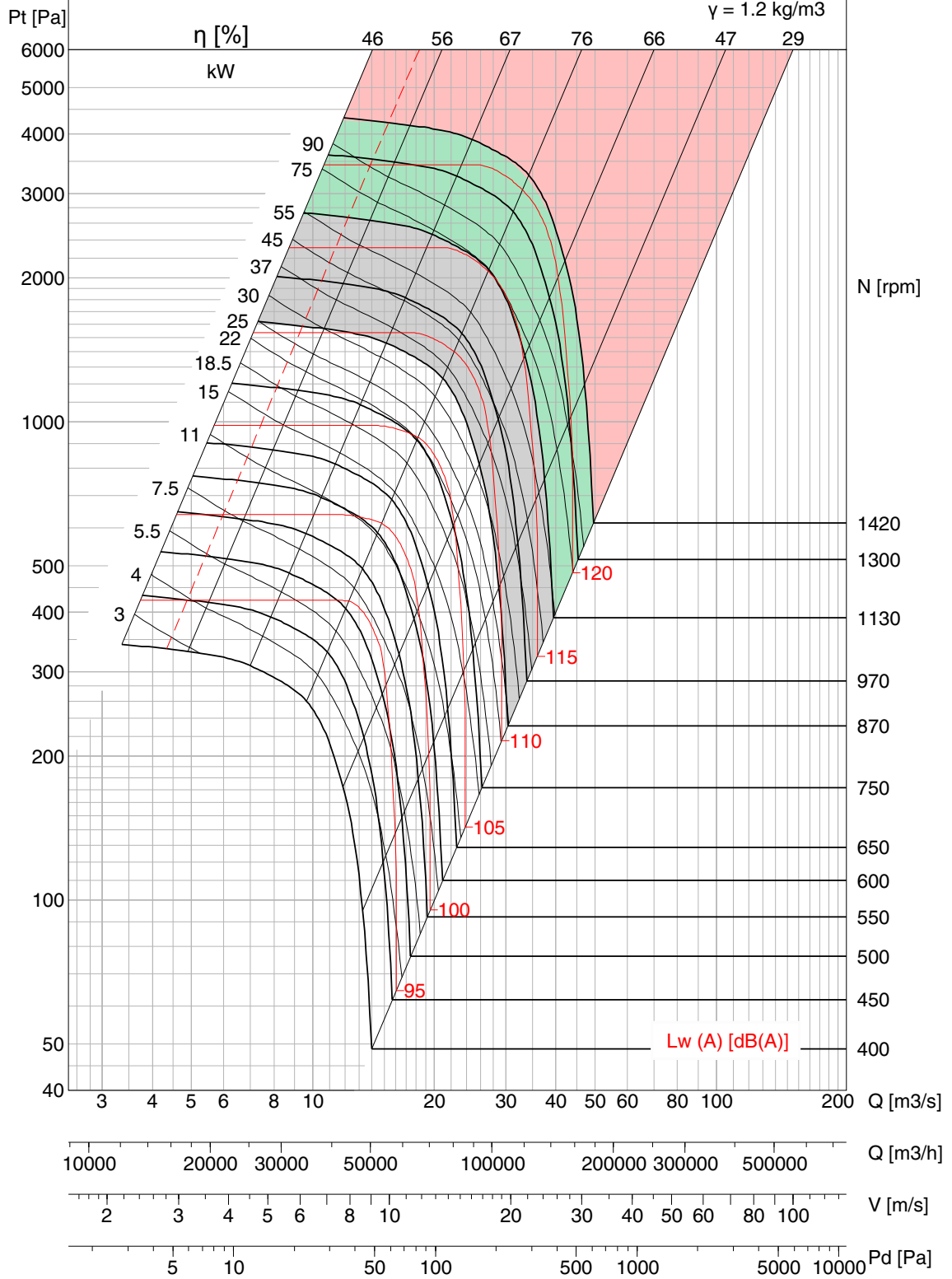

- Performance certified is for installation type A – free inlet, free outlet. Performance ratings do not include the effects of appurtenances (accessories).
- Power rating kW does not include transmission losses.
- Outlet Velocity of Model BNC is calculated in accordance with the fan outlet area as defined in AMCA 210 Annex H, Figure H.4.
- Values shown are for outlet Lwo A sound power levels for Installation Type A: free inlet, free outlet.
- The A-weighted sound ratings shown have been calculated per AMCA International Standard 301.
- Fan Efficiency Grade (FEG) is based on peak total efficiency in accordance with ISO 12759/ AMCA 205.
- Please consult Kruger for fan selection of class III.



BNC-Q 1250

FEG 80

Op Limit	Cl. I	Cl. II	Cl. III
Type	DI	DII	DIII
M.kW	42	94	183
M.RPM	890	1170	1460

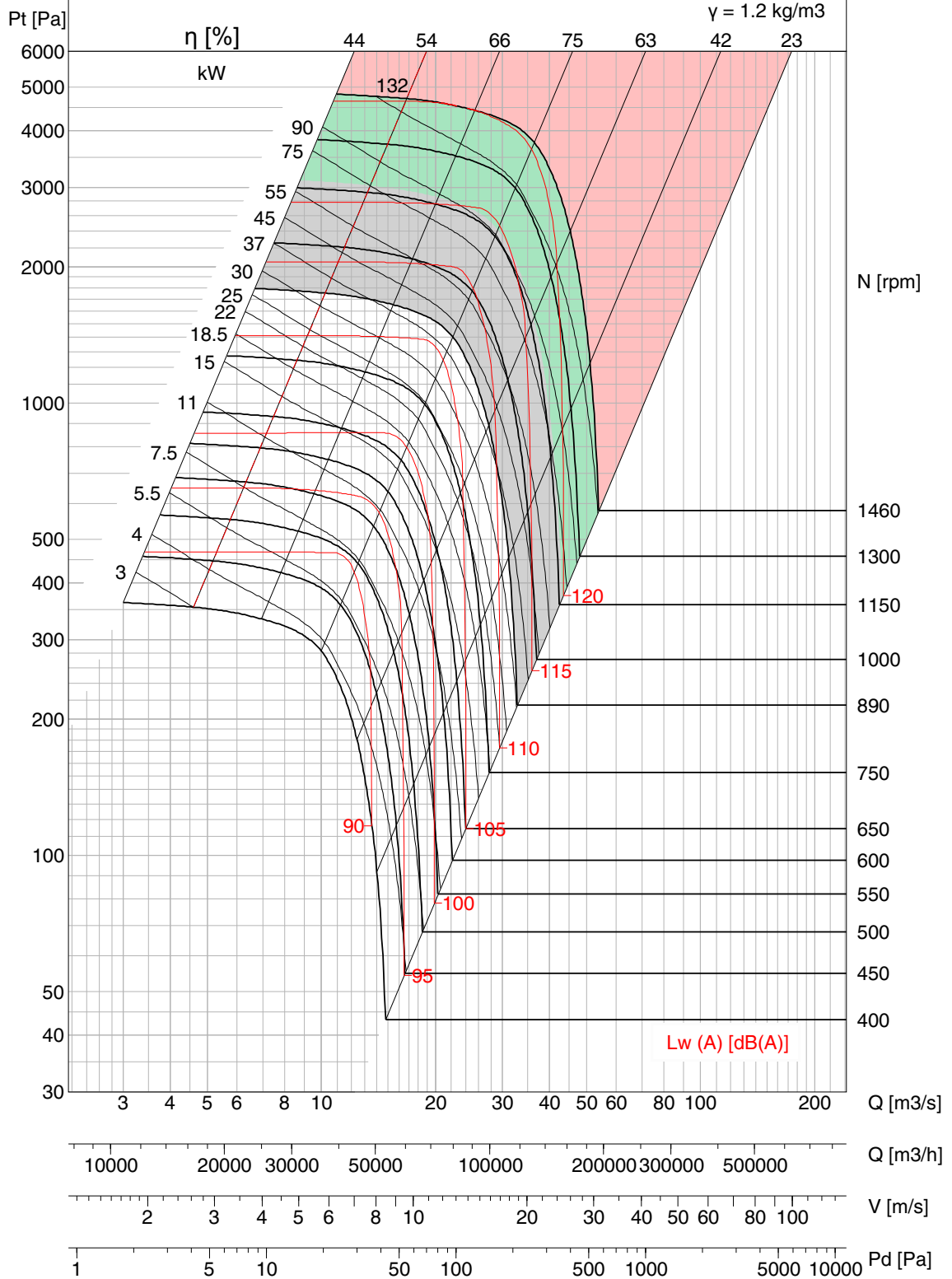

- Performance certified is for installation type A – free inlet, free outlet. Performance ratings do not include the effects of appurtenances (accessories).
- Power rating kW does not include transmission losses.
- Outlet Velocity of Model BNC is calculated in accordance with the fan outlet area as defined in AMCA 210 Annex H, Figure H.4.
- Values shown are for outlet Lwo A sound power levels for Installation Type A: free inlet, free outlet.
- The A-weighted sound ratings shown have been calculated per AMCA International Standard 301.
- Fan Efficiency Grade (FEG) is based on peak total efficiency in accordance with ISO 12759/ AMCA 205.
- Please consult Kruger for fan selection of class III.



BNC-P 1400

FEG 80

Op Limit	Cl. I	Cl. II	Cl. III
Type	DI	DII	DIII
M.kW	37	82	170
M.RPM	750	980	1250

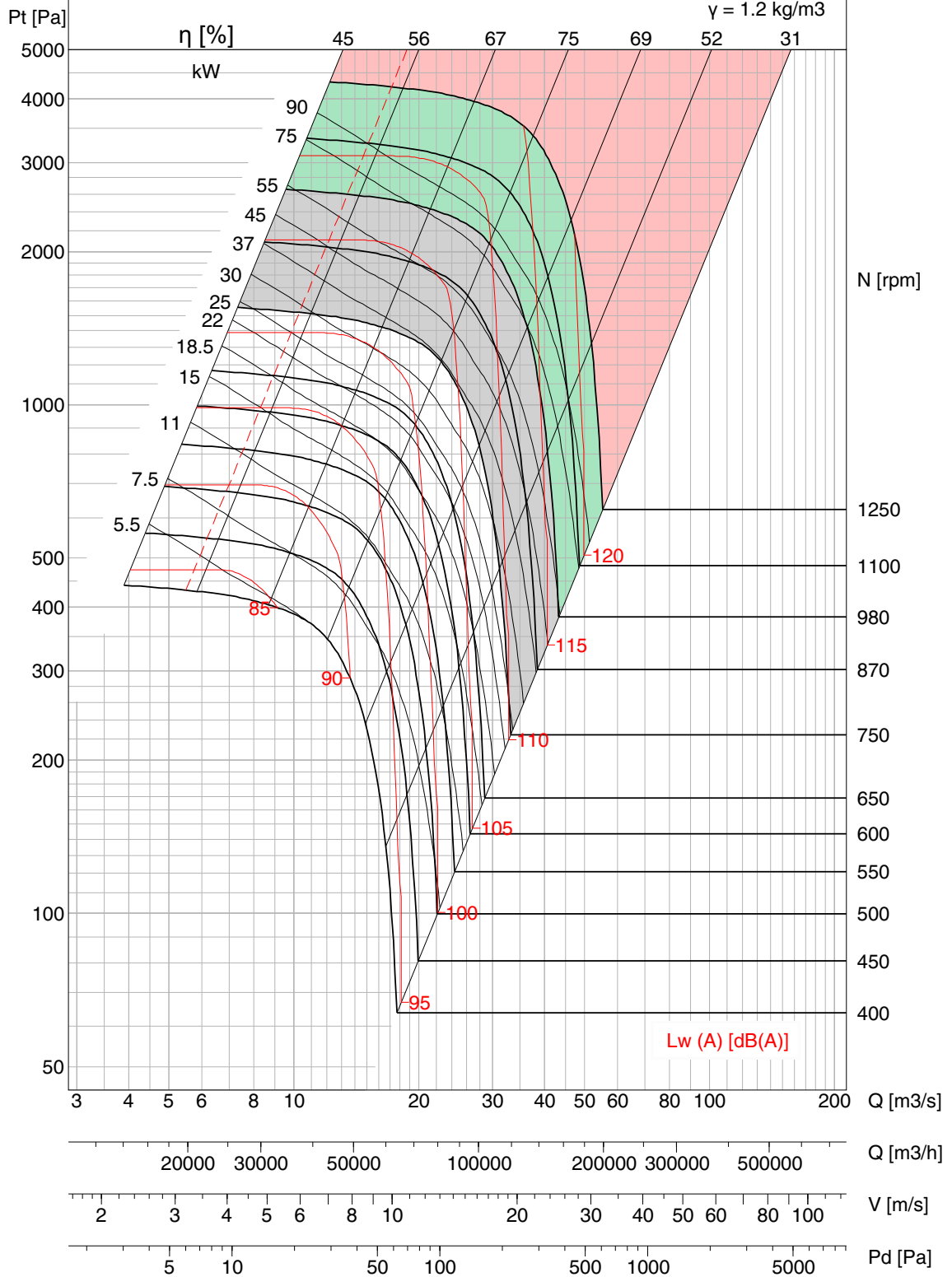

- Performance certified is for installation type A – free inlet, free outlet. Performance ratings do not include the effects of appurtenances (accessories). Power rating kW does not include transmission losses.
- Outlet Velocity of Model BNC is calculated in accordance with the fan outlet area as defined in AMCA 210 Annex H, Figure H.4.
- Values shown are for outlet Lwo A sound power levels for Installation Type A: free inlet, free outlet.
- The A-weighted sound ratings shown have been calculated per AMCA International Standard 301.
- Fan Efficiency Grade (FEG) is based on peak total efficiency in accordance with ISO 12759/ AMCA 205.
- Please consult Kruger for fan selection of class III.



BNC-R 1400

FEG 80

Op Limit	Cl. I	Cl. II	Cl. III
Type	DI	DII	DIII
M.kW	42	91.5	187
M.RPM	770	1000	1270

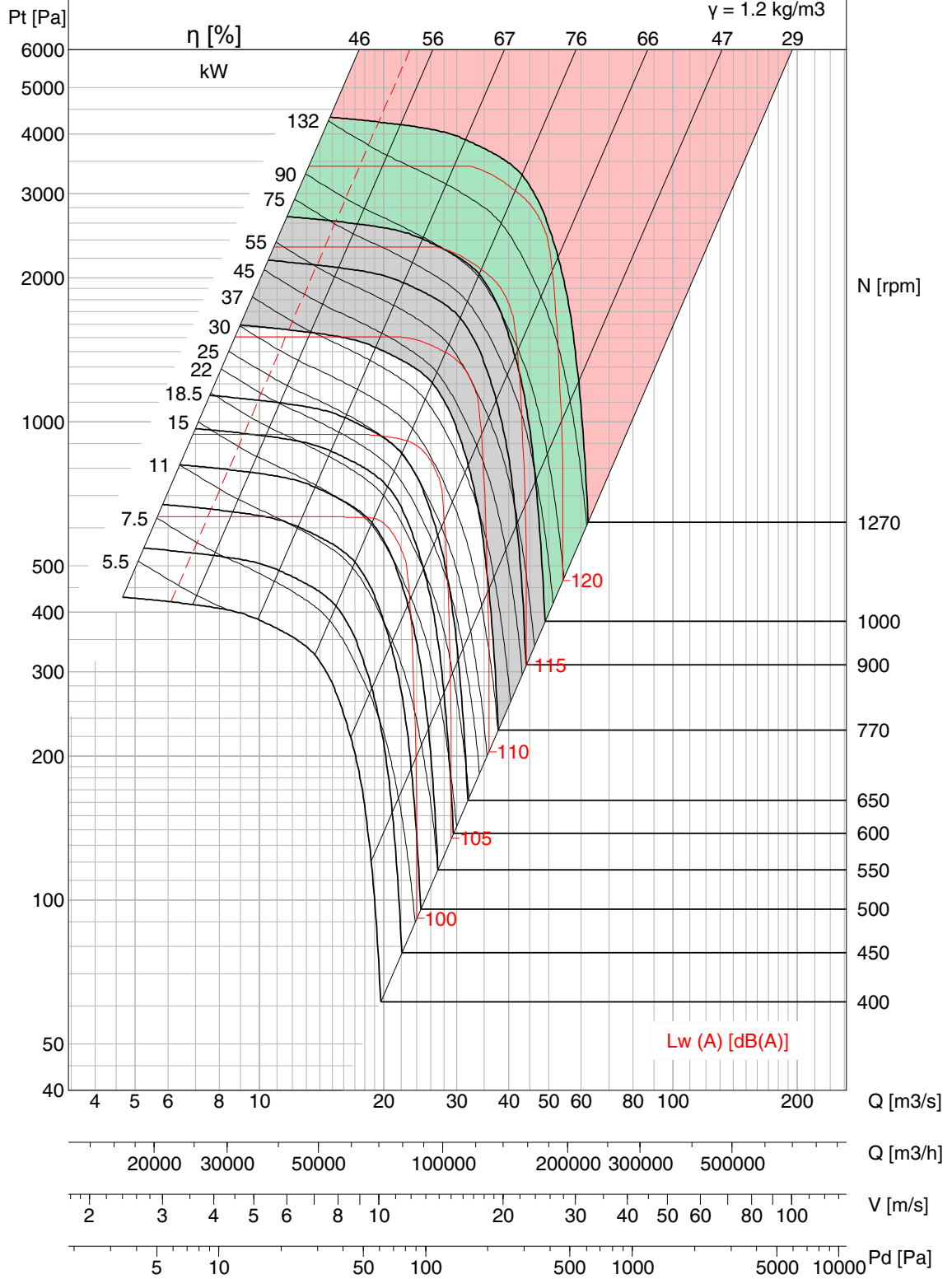

- Performance certified is for installation type A – free inlet, free outlet. Performance ratings do not include the effects of appurtenances (accessories).
- Power rating kW does not include transmission losses.
- Outlet Velocity of Model BNC is calculated in accordance with the fan outlet area as defined in AMCA 210 Annex H, Figure H.4.
- Values shown are for outlet Lwo A sound power levels for Installation Type A: free inlet, free outlet.
- The A-weighted sound ratings shown have been calculated per AMCA International Standard 301.
- Fan Efficiency Grade (FEG) is based on peak total efficiency in accordance with ISO 12759/ AMCA 205.
- Please consult Kruger for fan selection of class III.



BNC-Q 1400

FEG 80

Op Limit	Cl. I	Cl. II	Cl. III
Type	DI	DII	DIII
M.kW	53	113	227
M.RPM	800	1030	1300

$\gamma = 1.2 \text{ kg/m}^3$

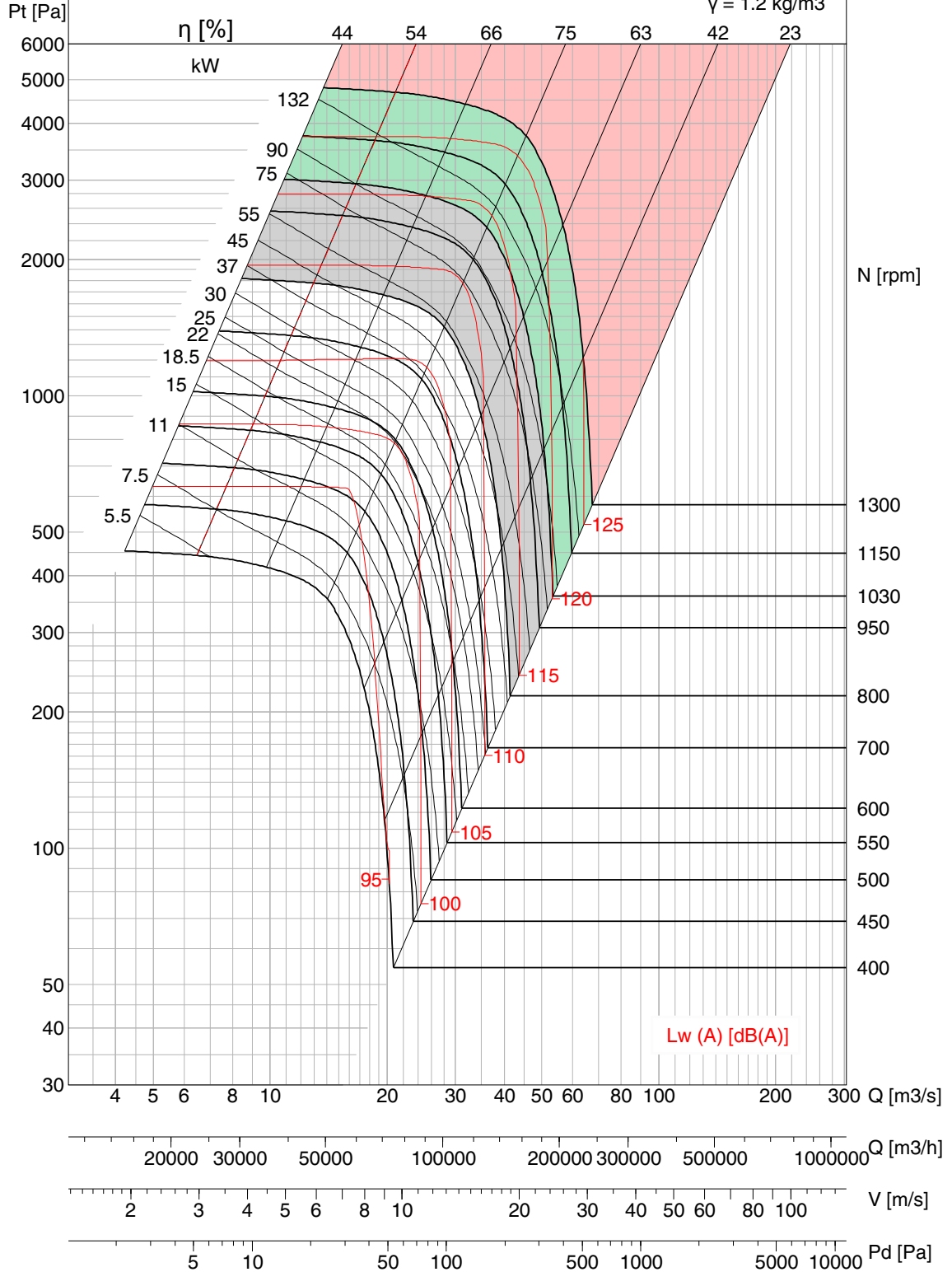

- Performance certified is for installation type A – free inlet, free outlet. Performance ratings do not include the effects of appurtenances (accessories). Power rating kW does not include transmission losses.
- Outlet Velocity of Model BNC is calculated in accordance with the fan outlet area as defined in AMCA 210 Annex H, Figure H.4.
- Values shown are for outlet Lwo A sound power levels for Installation Type A: free inlet, free outlet.
- The A-weighted sound ratings shown have been calculated per AMCA International Standard 301.
- Fan Efficiency Grade (FEG) is based on peak total efficiency in accordance with ISO 12759/ AMCA 205.
- Please consult Kruger for fan selection of class III.



BNC-P 1600

FEG 80

Op Limit	Cl. I	Cl. II	Cl. III
Type	DI	DII	DIII
M.kW	49	108	225
M.RPM	660	860	1100

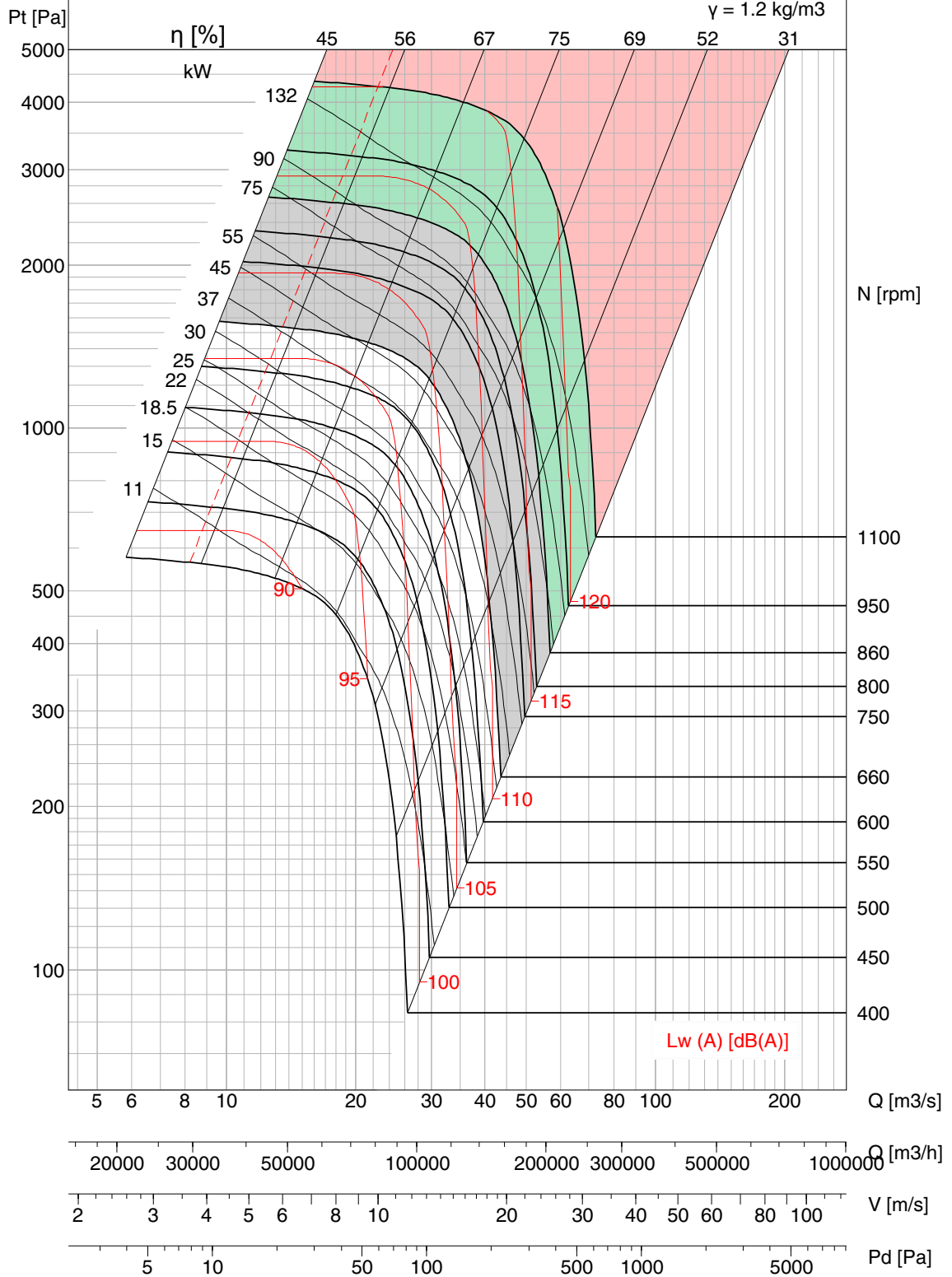

- Performance certified is for installation type A – free inlet, free outlet. Performance ratings do not include the effects of appurtenances (accessories). Power rating kW does not include transmission losses.
- Outlet Velocity of Model BNC is calculated in accordance with the fan outlet area as defined in AMCA 210 Annex H, Figure H.4.
- Values shown are for outlet Lwo A sound power levels for Installation Type A: free inlet, free outlet.
- The A-weighted sound ratings shown have been calculated per AMCA International Standard 301.
- Fan Efficiency Grade (FEG) is based on peak total efficiency in accordance with ISO 12759/ AMCA 205.
- Please consult Kruger for fan selection of class III.



BNC-R 1600

FEG 80

Op Limit	Cl. I	Cl. II	Cl. III
Type	DI	DII	DIII
M.kW	56	121.5	244
M.RPM	680	880	1110

$\gamma = 1.2 \text{ kg/m}^3$

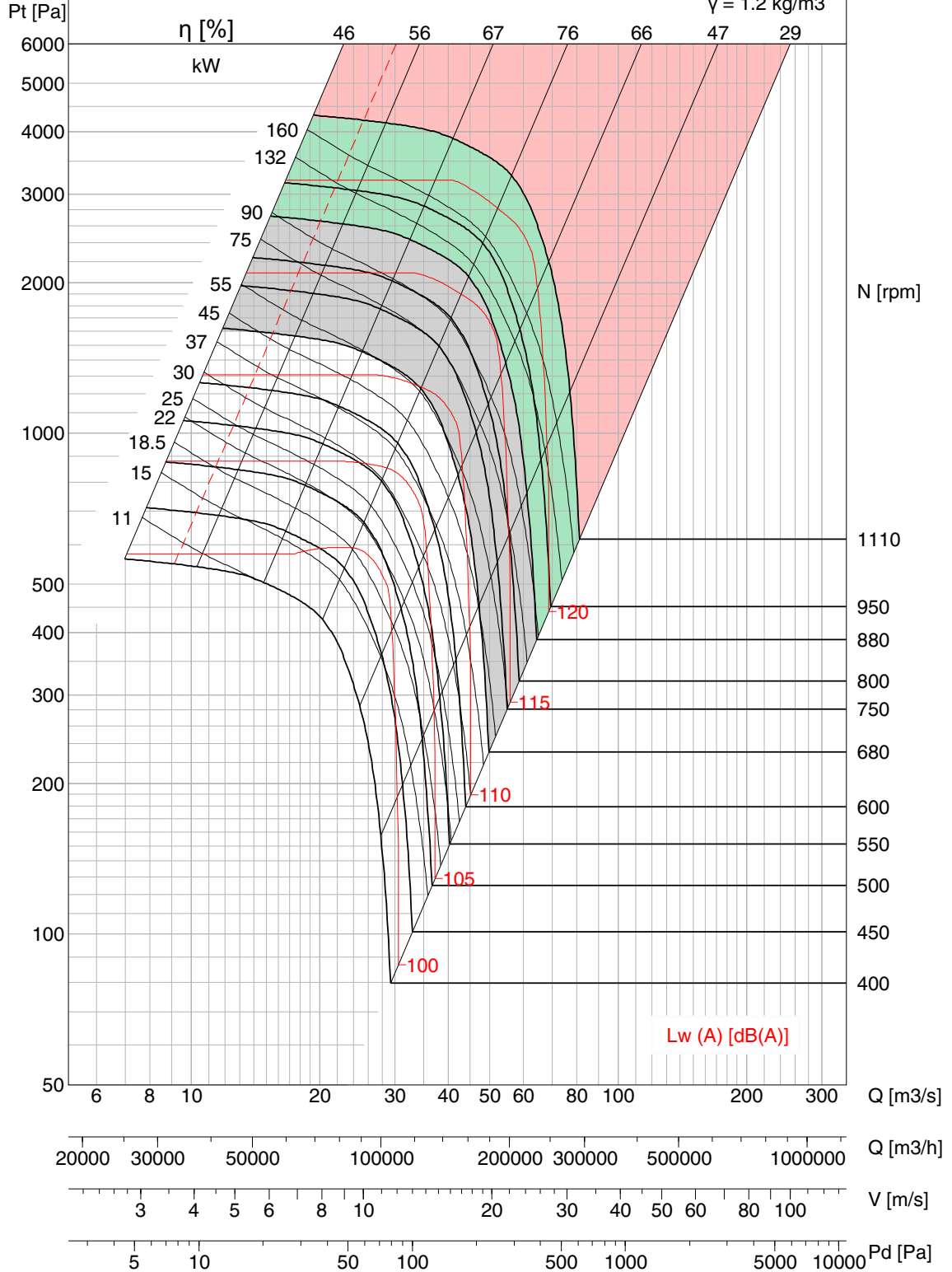

- Performance certified is for installation type A – free inlet, free outlet. Performance ratings do not include the effects of appurtenances (accessories).
- Power rating kW does not include transmission losses.
- Outlet Velocity of Model BNC is calculated in accordance with the fan outlet area as defined in AMCA 210 Annex H, Figure H.4.
- Values shown are for outlet Lwo A sound power levels for Installation Type A: free inlet, free outlet.
- The A-weighted sound ratings shown have been calculated per AMCA International Standard 301.
- Fan Efficiency Grade (FEG) is based on peak total efficiency in accordance with ISO 12759/ AMCA 205.
- Please consult Kruger for fan selection of class III.



BNC-Q 1600

FEG 80

Op Limit	Cl. I	Cl. II	Cl. III
Type	DI	DII	DIII
M.kW	69	147	306
M.RPM	700	900	1150

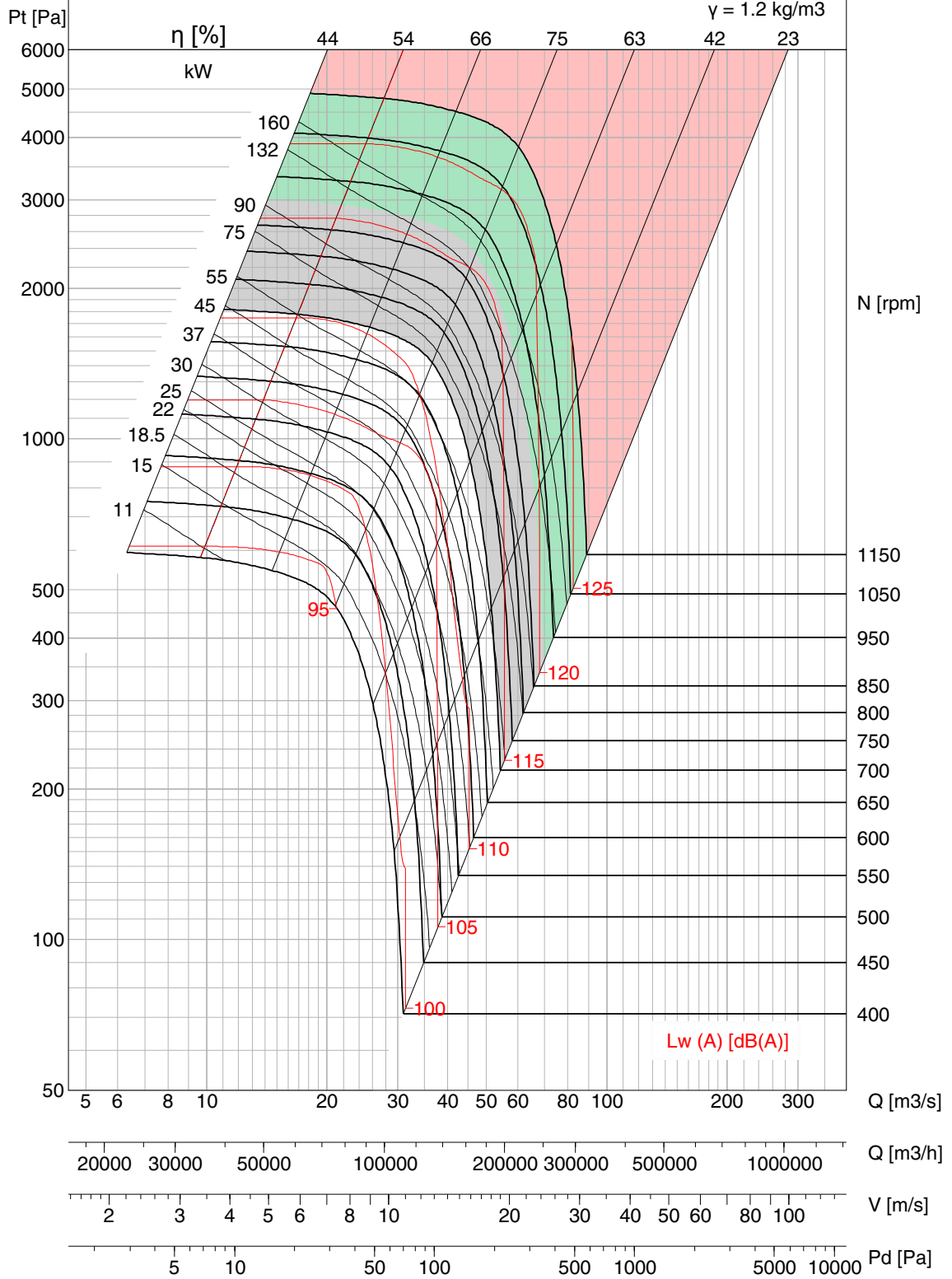

- Performance certified is for installation type A – free inlet, free outlet. Performance ratings do not include the effects of appurtenances (accessories). Power rating kW does not include transmission losses.
- Outlet Velocity of Model BNC is calculated in accordance with the fan outlet area as defined in AMCA 210 Annex H, Figure H.4.
- Values shown are for outlet Lwo A sound power levels for Installation Type A: free inlet, free outlet.
- The A-weighted sound ratings shown have been calculated per AMCA International Standard 301.
- Fan Efficiency Grade (FEG) is based on peak total efficiency in accordance with ISO 12759/ AMCA 205.
- Please consult Kruger for fan selection of class III.



BNC-P 1800

FEG 80

Op Limit	Cl. I	Cl. II	Cl. III
Type	DI	DII	DIII
M.kW	63	140	280
M.RPM	590	770	970

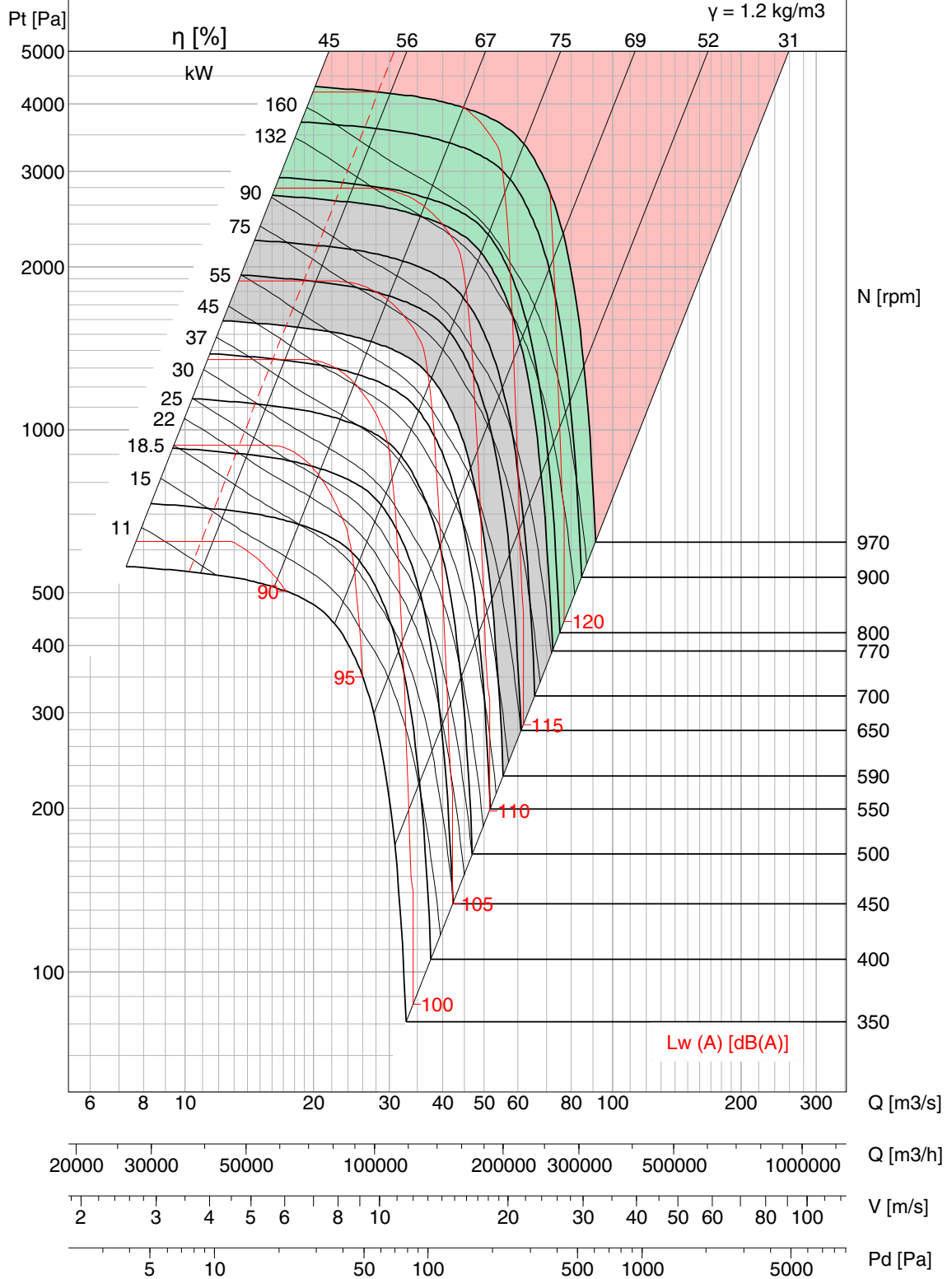

- Performance certified is for installation type A – free inlet, free outlet. Performance ratings do not include the effects of appurtenances (accessories). Power rating kW does not include transmission losses.
- Outlet Velocity of Model BNC is calculated in accordance with the fan outlet area as defined in AMCA 210 Annex H, Figure H.4.
- Values shown are for outlet Lwo A sound power levels for Installation Type A: free inlet, free outlet.
- The A-weighted sound ratings shown have been calculated per AMCA International Standard 301.
- Fan Efficiency Grade (FEG) is based on peak total efficiency in accordance with ISO 12759/ AMCA 205.
- Please consult Kruger for fan selection of class III.



BNC-R 1800

FEG 80

Op Limit	Cl. I	Cl. II	Cl. III
Type	DI	DII	DIII
M.kW	69.3	152	302
M.RPM	600	780	980

$\gamma = 1.2 \text{ kg/m}^3$

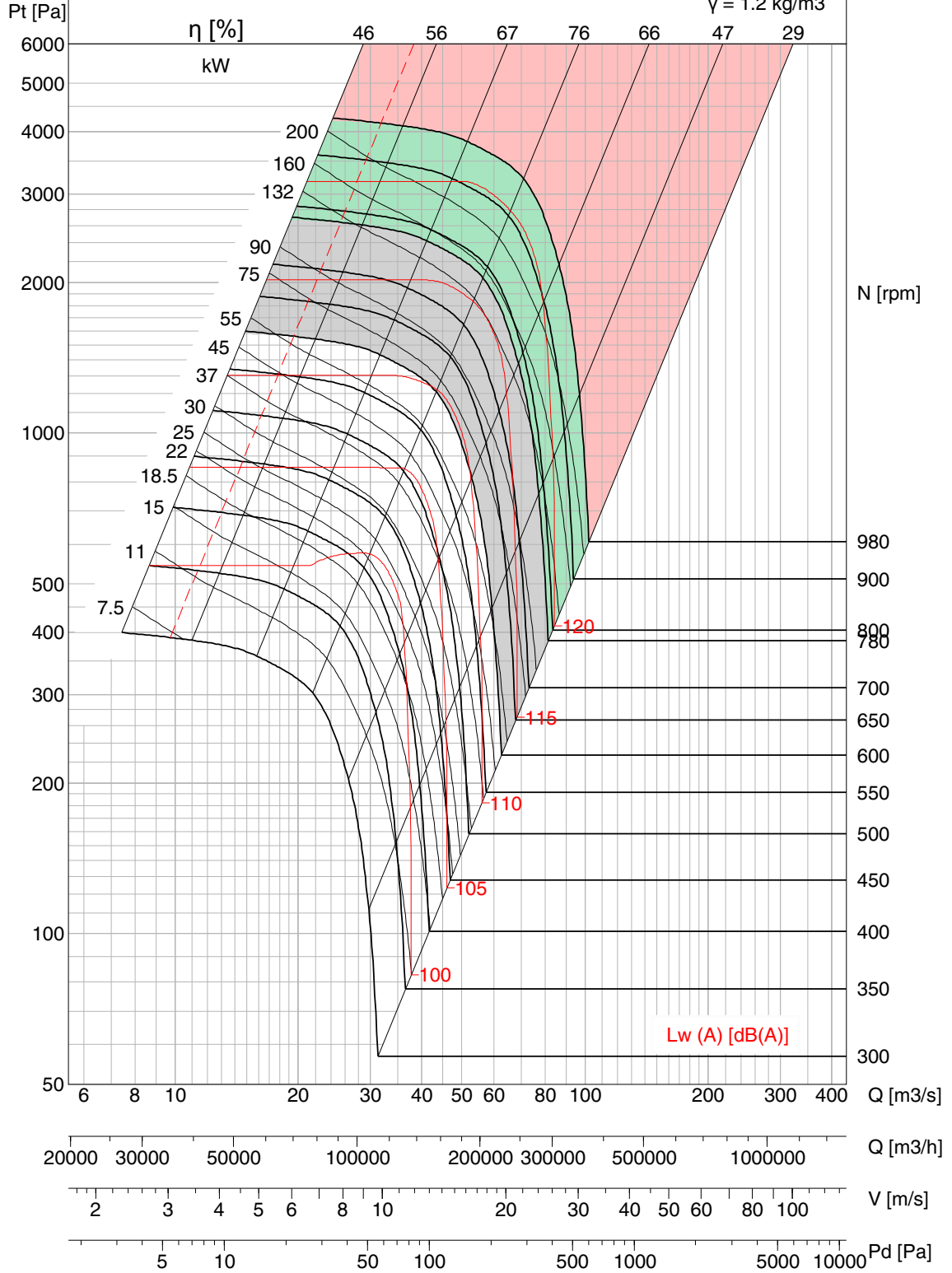

- Performance certified is for installation type A – free inlet, free outlet. Performance ratings do not include the effects of appurtenances (accessories).
- Power rating kW does not include transmission losses.
- Outlet Velocity of Model BNC is calculated in accordance with the fan outlet area as defined in AMCA 210 Annex H, Figure H.4.
- Values shown are for outlet Lwo A sound power levels for Installation Type A: free inlet, free outlet.
- The A-weighted sound ratings shown have been calculated per AMCA International Standard 301.
- Fan Efficiency Grade (FEG) is based on peak total efficiency in accordance with ISO 12759/ AMCA 205.
- Please consult Kruger for fan selection of class III.



BNC-Q 1800

FEG 80

Op Limit	Cl. I	Cl. II	Cl. III
Type	DI	DII	DIII
M.kW	87	193	385
M.RPM	620	810	1020

$\gamma = 1.2 \text{ kg/m}^3$

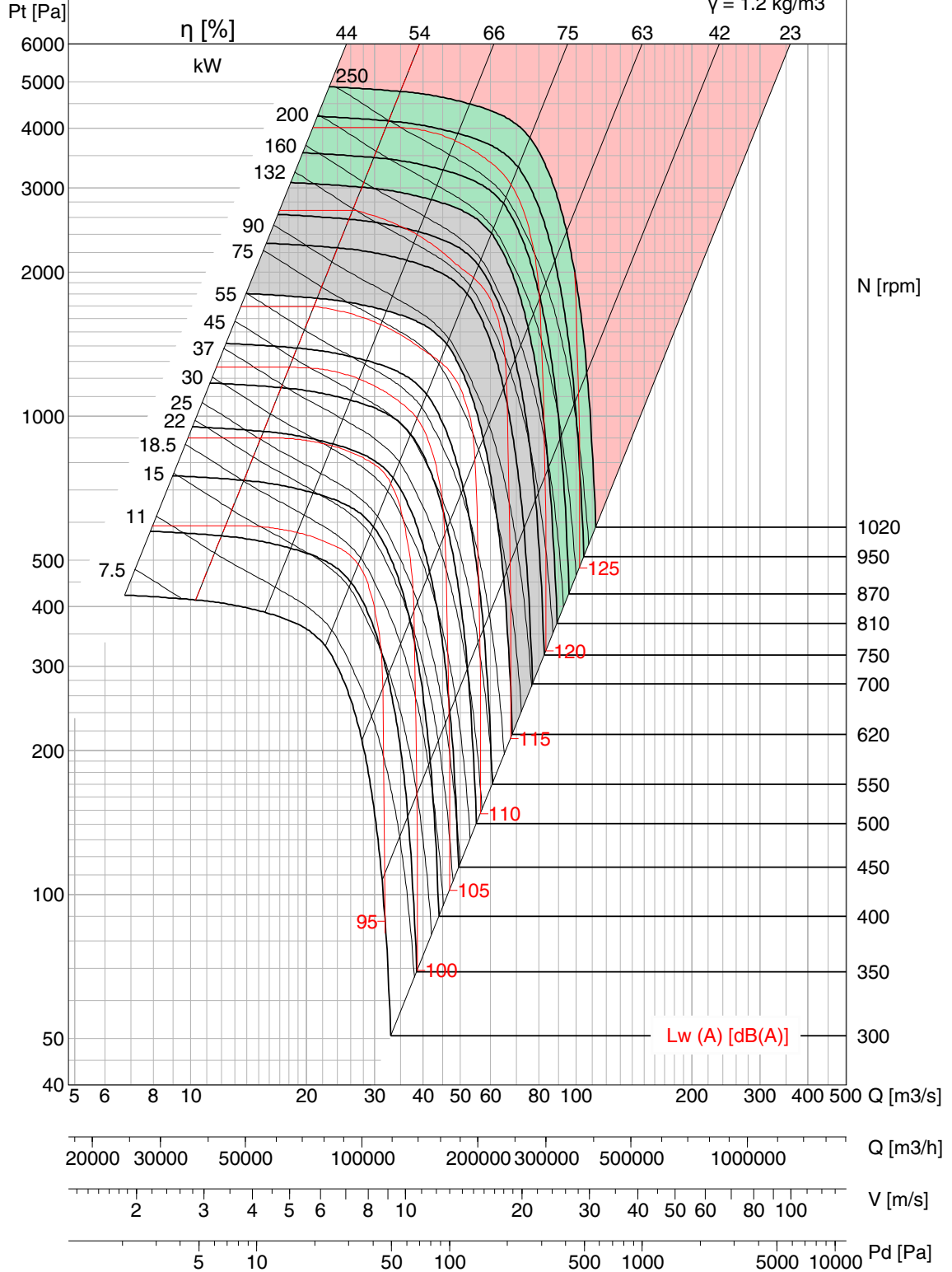

- Performance certified is for installation type A – free inlet, free outlet. Performance ratings do not include the effects of appurtenances (accessories).
- Power rating kW does not include transmission losses.
- Outlet Velocity of Model BNC is calculated in accordance with the fan outlet area as defined in AMCA 210 Annex H, Figure H.4.
- Values shown are for outlet Lwo A sound power levels for Installation Type A: free inlet, free outlet.
- The A-weighted sound ratings shown have been calculated per AMCA International Standard 301.
- Fan Efficiency Grade (FEG) is based on peak total efficiency in accordance with ISO 12759/ AMCA 205.
- Please consult Kruger for fan selection of class III.

BNC 315~630'D'

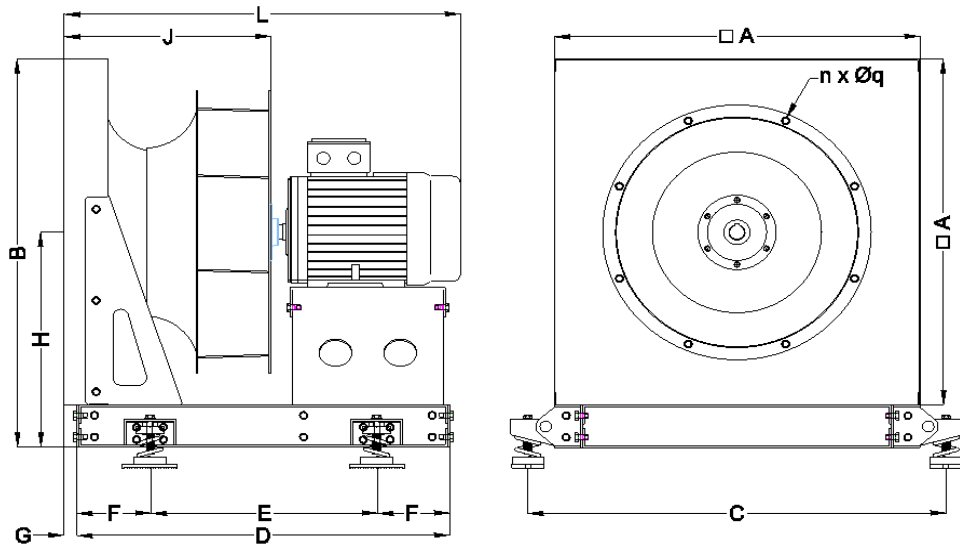

Model	A	B	C	D	E	n x Øq	L			Frame Size	F	G	H	J			Wt (Kg) w/o
							Fan Type							Fan Type			
							P	R	Q					P	R	Q	
315	490	555	588	525	325	6 x 9	513	526	536	71	100	28	310	266	279	289	20
				565	365		543	556	566	80							
							588	601	611	90							
							603	616	626	100							
							643	656	666	112							
355	530	595	628	580	340	6 x 9	562	575	587	80	120	28	330	289	303	315	29
				650	410		607	620	632	90							
							622	635	647	100							
							707	720	732	112							
							867	880	892	132							
400	580	645	678	613	353	8 x 9	629	645	658	90	130	28	355	322	338	351	38
				803	543		674	690	703	100							
							684	700	713	112							
							779	795	808	132							
							939	955	968	160							
450	630	715	730	673	393	8 x 12	667	685	703	90	140	28	400	358	376	394	50
				863	583		712	730	748	100							
							727	745	763	112							
							797	815	833	132							
							972	990	1008	160							
500	700	785	800	714	434	8 x 12	706	725	747	90	140	28	435	392	412	434	60
				904	624		746	765	787	100							
							766	785	807	112							
							861	880	902	132							
							1021	1040	1062	160							
560	790	875	890	820	500	8 x 12	768	790	813	100	160	28	480	431	452	476	76
				990	670		783	805	828	112							
							883	905	928	132							
							1033	1055	1078	160							
							1063	1085	1108	180							
630	890	990	990	865	545	8 x 12	825	850	870	100	160	28	545	471	496	517	95
				1035	715		840	865	885	112							
							925	950	970	132							
							1065	1090	1110	160							
							1090	1115	1135	180							

All Dimensions in mm

BNC 710~1000'D'

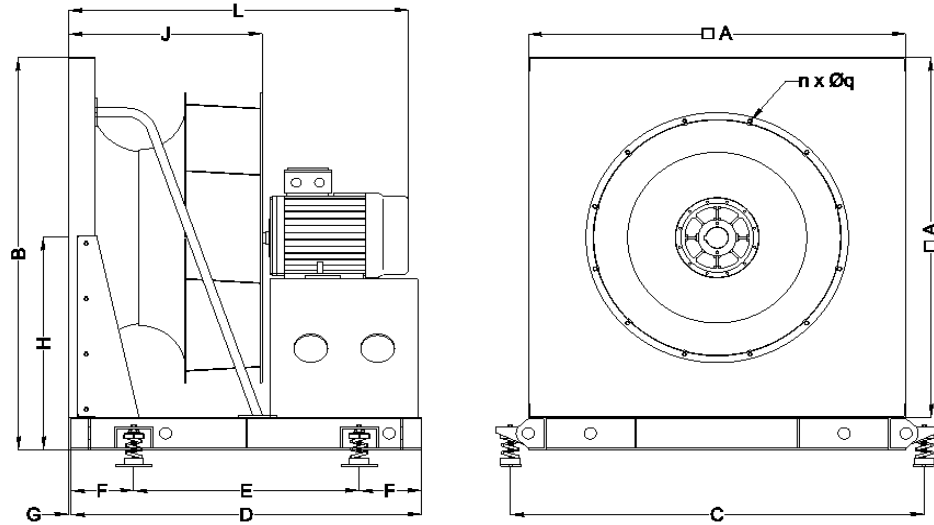

Model	A	B	C	D	E	n x Øq	L			Frame Size	F	G	H	J			Wt (Kg) w/o
							Fan Type							Fan Type			
							P	R	Q					P	R	Q	
710	1000	1100	1100	938	618	8 x 12	888	916	939	112	160	28	600	522	550	573	112
							983	1011	1034	132							
				1123	1151		1174	160									
				1148	1176		1199	180									
				1223	1251		1274	200									
800	1130	1230	1230	1130	810	8 x 12	1024	1056	1082	132	160	28	660	575	607	633	151
							1159	1191	1217	160							
				1194	1226		1252	180									
				689	721		747	200									
				849	881		907	225									
900	1240	1340	1340	1252	912	12 x 12	1225	1259	1289	160	170	28	720	630	665	695	209
							1255	1289	1319	180							
				1325	1359		1389	200									
				1390	1424		1454	225									
				1455	1489		1519	250									
1000	1390	1515	1520	1334	874	12 x 12	1291	1329	1362	160	230	28	820	713	751	784	261
							1321	1359	1392	180							
				1391	1429		1462	200									
				1446	1484		1517	225									
				1516	1554		1587	250									

All Dimensions in mm

BNC 1120~1800'D'

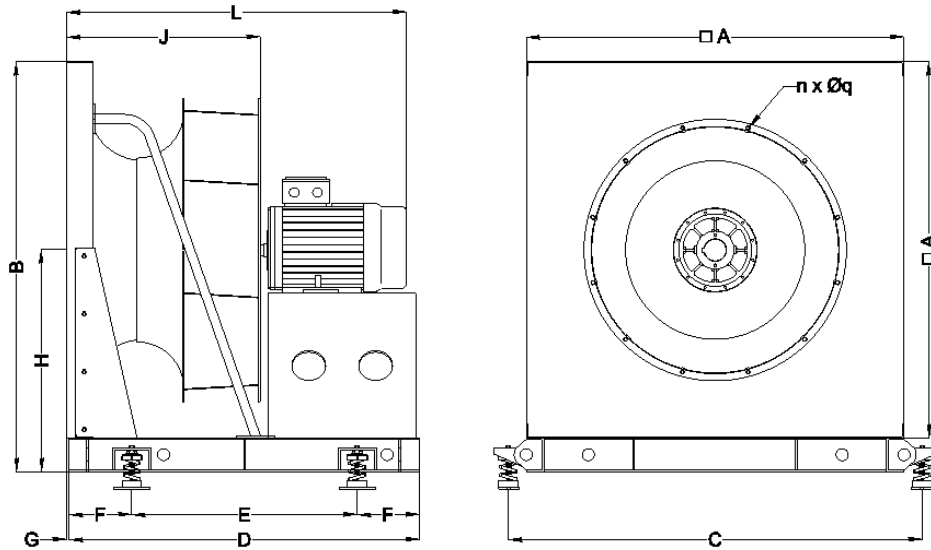

Model	A	B	C	D	E	n x Øq	L			Frame Size	F	G	H	J			Wt (Kg) w/o
							Fan Type							Fan Type			
							P	R	Q					P	R	Q	
1120	1550	1675	1680	1450	900	12 x 12	1410	1454	1491	180	275	28	925	807	851	888	333
							1480	1524	1561	200							
				1515	1559		1596	225									
				1604	1639		1676	250									
				1705	1749		1786	280									
1250	1722	1847	1852	1540	940	14 x 12	1494	1544	1585	180	300	28	1000	872	922	963	408
							1564	1614	1655	200							
				1599	1649		1690	225									
				1664	1714		1755	250									
				1789	1839		1880	280									
1400	1928	2078	2058	1612	1012	16 x 16	1563	1617	1666	180	300	28	1100	952	1006	1052	408
							1633	1687	1736	200							
				1678	1732		1781	225									
				1743	1797		1846	250									
				1868	1922		1971	280									
1600	2204	2354	2354	1882	1252	18 x 16	1695	1768	1821	200	315	28	1252	1100	1173	1226	512
							1740	1813	1866	225							
				1805	1878		1931	250									
				1895	1968		2021	280									
				2175	2248		2301	315									
1800	2480	2630	2630	2117	1487	32 x 16	1912	1983	2043	225	315	28	1390	1272	1343	1403	570
							1977	2048	2108	250							
				2067	2138		2198	280									
				2347	2418		2478	315									
				2722	2793		2853	355									

All Dimensions in mm

Operational Limits - BNC-P

	315	355	400	450	500	560	630	710	800	900	1000	1120	1250	1400	1600	1800		
Maximum Absorbed Power	CL.I	kW	2.2	3	3.3	4.3	5.3	6.4	7.4	9.7	12.3	15.3	19.3	30.3	37	49	63	
	CL.II	kW	5	6	7.2	9.5	11.5	13.4	16	21.3	26.7	33.5	42.4	53	65.5	82	108	140
	CL.III	kW	9.7	11.5	14	19	23.2	26.7	33	42.3	53	67.4	86.5	106	135	170	225	280
Maximum Fan Speed	CL.I	rpm	3500	3100	2750	2450	2200	1950	1700	1520	1350	1170	1060	950	850	750	660	590
	CL.II	rpm	4600	4000	3550	3170	2850	2500	2200	1980	1750	1520	1380	1230	1100	980	860	770
	CL.III	rpm	5800	5000	4450	4000	3600	3150	2800	2490	2200	1920	1750	1550	1400	1250	1100	970
Temperature Range/ Min. -20°C	CL.I-CL.III	Max.°C	55	55	55	55	55	55	55	55	55	55	55	55	55	55	55	55
Wheel	Diameter	mm	315	355	400	450	500	560	630	710	800	900	1000	1120	1250	1400	1600	1800
	J = PD ² /4	kgm ²	0.13	0.22	0.34	0.62	1.07	1.88	2.99	5.27	9.52	14.7	24.7	45.1	72.4	117	234	405

Operational Limits - BNC-R

	315	355	400	450	500	560	630	710	800	900	1000	1120	1250	1400	1600	1800		
Maximum Absorbed Power	CL.I	kW	2.4	3	4.6	4.6	6	7.1	9	11	14.6	18	21.4	34	42	56	69.3	
	CL.II	kW	5.2	6.8	10	10.6	13	15.6	19	25	31.5	39	47	58.5	75	91.5	121.5	152
	CL.III	kW	10.4	13.3	20	21.5	27	31.5	38	49	62	78	94	118	145	187	244	302
Maximum Fan Speed	CL.I	rpm	3550	3180	3000	2470	2220	1950	1720	1530	1370	1210	1080	970	870	770	680	600
	CL.II	rpm	4600	4150	3890	3200	2880	2540	2230	1990	1770	1570	1400	1250	1130	1000	880	780
	CL.III	rpm	5800	5200	4900	4050	3650	3200	2800	2500	2220	1980	1770	1580	1420	1270	1110	980
Temperature Range/ Min. -20°C	CL.I-CL.III	Max.°C	55	55	55	55	55	55	55	55	55	55	55	55	55	55	55	55
Wheel	Diameter	mm	315	355	400	450	500	560	630	710	800	900	1000	1120	1250	1400	1600	1800
	J = PD ² /4	kgm ²	0.13	0.23	0.36	0.64	1.12	1.95	3.11	5.53	10.0	15.4	26.0	47.0	75.5	122	244	420

Operational Limits - BNC-Q

	315	355	400	450	500	560	630	710	800	900	1000	1120	1250	1400	1600	1800		
Maximum Absorbed Power	CL.I	kW	3	4	5	6.1	7.6	9	11	13.8	18.7	22.2	27	34	42	53	69	87
	CL.II	kW	6.5	8.6	11	13.6	16.7	20.5	24	31.2	38.8	46.5	59	74.5	94	113	147	193
	CL.III	kW	13	17	22	27.5	33.5	40.8	50	62.7	79.4	97.7	122	152	183	227	306	385
Maximum Fan Speed	CL.I	rpm	3700	3370	2900	2600	2350	2050	1800	1600	1450	1250	1120	1000	890	800	700	620
	CL.II	rpm	4800	4370	3750	3400	3050	2700	2350	2100	1850	1600	1450	1300	1170	1030	900	810
	CL.III	rpm	6100	5500	4750	4300	3850	3400	3000	2650	2350	2050	1850	1650	1460	1300	1150	1020
Temperature Range/ Min. -20°C	CL.I-CL.III	Max.°C	55	55	55	55	55	55	55	55	55	55	55	55	55	55	55	55
Wheel	Diameter	mm	315	355	400	450	500	560	630	710	800	900	1000	1120	1250	1400	1600	1800
	J = PD ² /4	kgm ²	0.14	0.24	0.37	0.67	1.16	2.01	3.21	5.75	10.3	15.9	27.0	48.7	78.1	126	253	434

NOTES

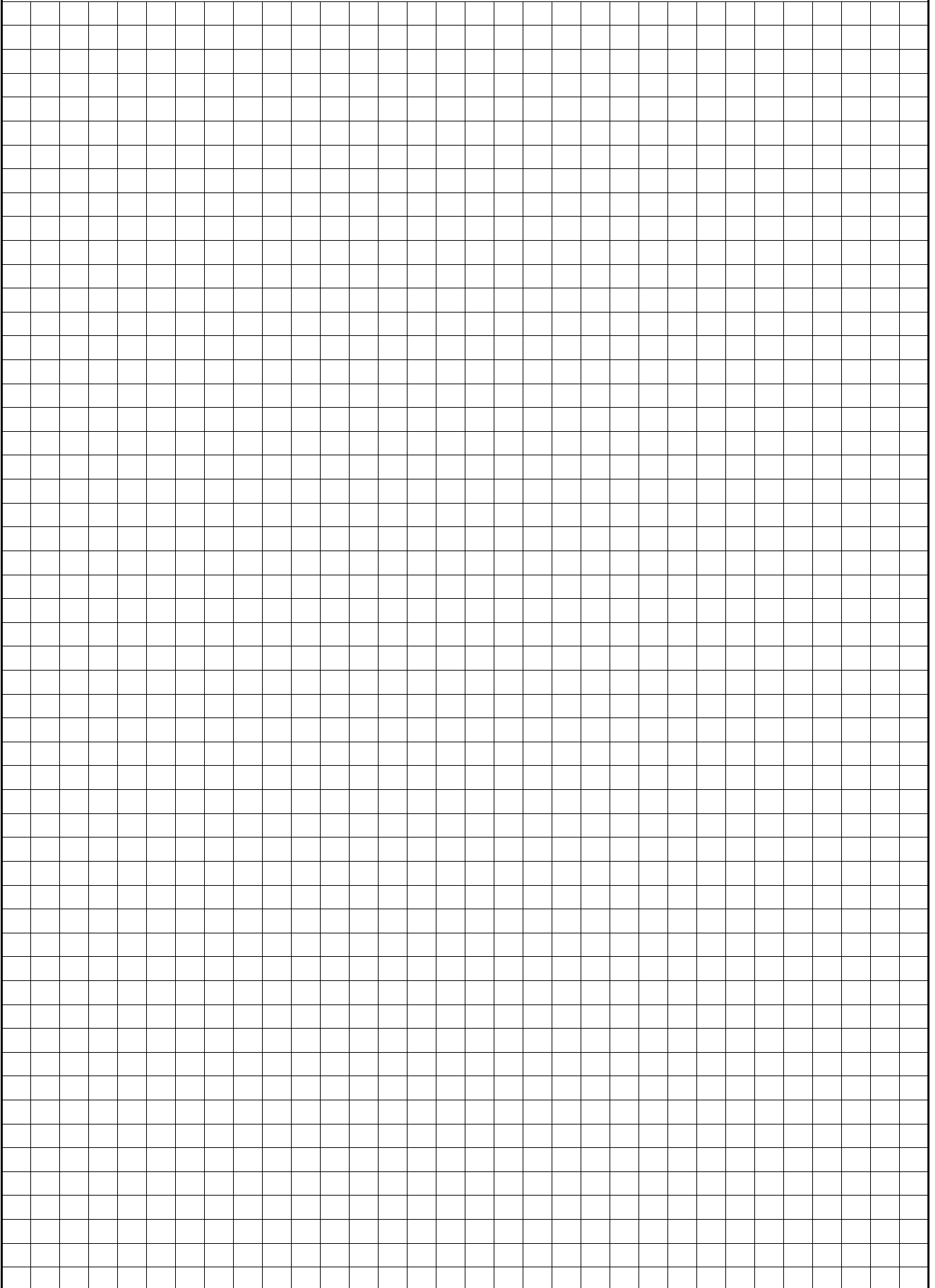

NOTES

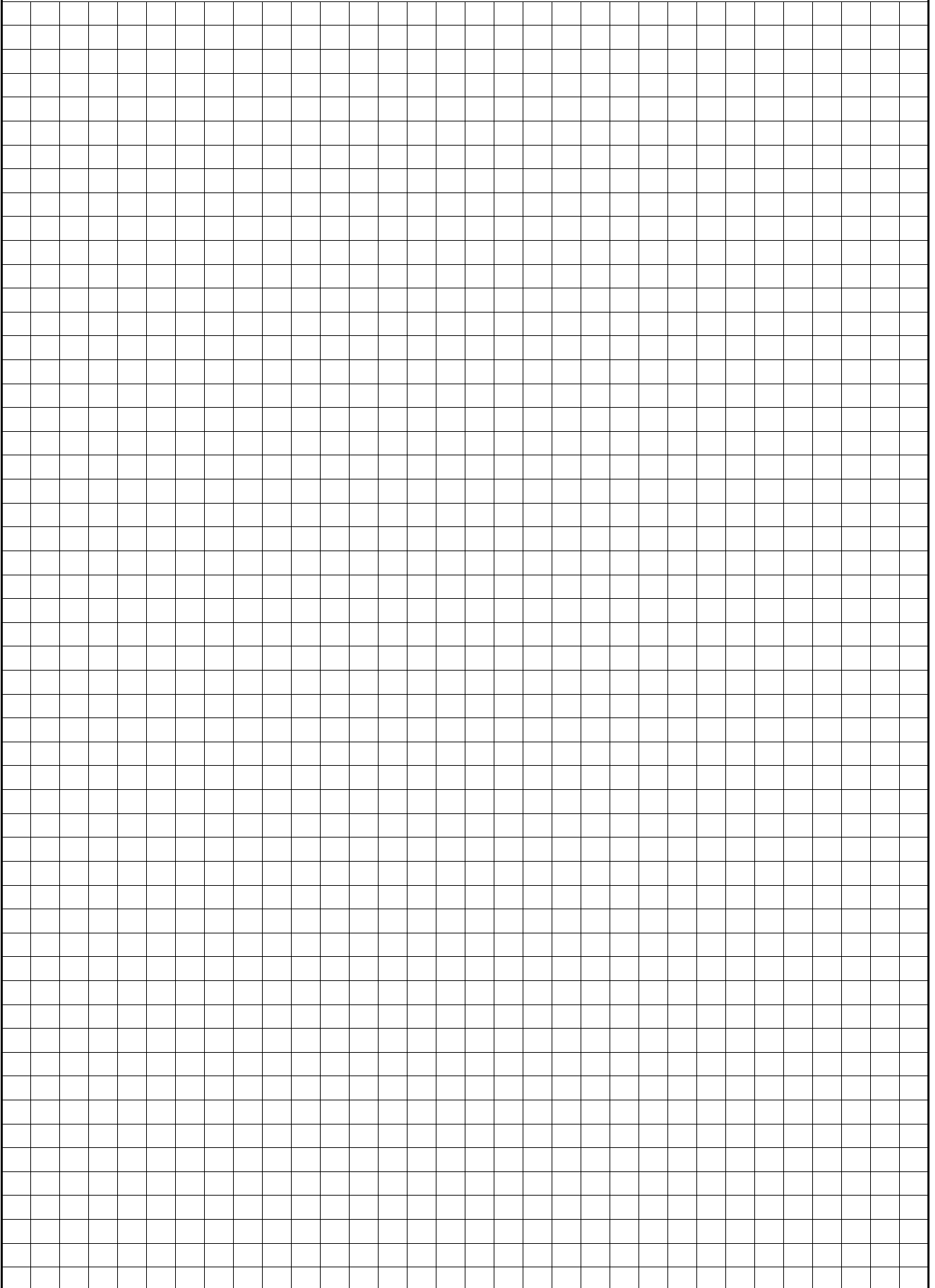

KRUGER GROUP (VENTILATION)

• THAILAND (Regional HQ)

KRUGER VENTILATION INDUSTRIES ASIA CO. LTD.
30/159 Moo 1, Sinsakorn Industrial Estate,
Chetsadawithi Road, Khok Kham Mueng, Samuthsakorn 74000, Thailand
Tel. +662 1054298 - Fax +662 0248256-9
Website: www.krugerfan.com

• CHINA (BEIJING)

BEIJING KRUGER VENTILATION CO. LTD
Level 7, A Block, Rising International Building, 29 JingHai San Road, BDA,
Beijing, P.R.China 100176
Tel. +86 10-67881366 - Fax +86 10-67880566
Email: krugertj@krugertj.com

• CHINA (SHANGHAI)

SHANGHAI KRUGER VENTILATION CO. LTD
No. 500 Yuanguo Road, Anting, Jiading,
Shanghai 201814 P.R. China
Tel. +86 21-69573266 - Fax +86 21-69573296
Email: shkruiger@krugerchina.com

• CHINA (WUHAN)

WUHAN KRUGER VENTILATION CO. LTD
No. 805, Huian Ave, Dongxihu District, Wuhan, Hubei, P.R. China 430000
Tel. +86 27- 83248840/83060522/83097505
Fax +86 27- 83261886
Email: whkruger@krugerwh.com

• HONG KONG

KRUGER VENTILATION (HONG KONG) LIMITED
Flat C, 9/F, Yeung Yiu Chung (No.8) Industrial Building,
20 Wang Hoi Road, Kowloon Bay, Kowloon, Hong Kong
Tel. +852 22469182 - Fax +852 22469187
Email: info@kruger.com.hk

• INDIA (NORTH)

KRUGER VENTILATION INDUSTRIES (NORTH INDIA) PVT LTD
Plot No. - 191, Sector - 59, Ballabgarh, Faridabad - 121 004, Haryana, India
Tel. +91-9958991660/9717449696
Fax. +91-1294135820
Email: sales.kni@krugerindia.com

• KOREA

NEOMATE CO. LTD
2-1010, Ace High Tech City B/D, 775 Gyeongin-ro,
Yeongdeungpo-gu, Seoul, Korea. Postal Code 07299
Tel. +82-2-2679-2052 - Fax. +82-2-2679-2174
Email: y7890@neomate.co.kr

• MYANMAR

KRUGER VENTILATION (MYANMAR) CO.LTD
Room No. F21, Thiri Yadanar Whole Sale Market, (Htawunbe)
Toe Chae Ward, North Okkalapa Township, Yangon.
Tel. +959 763141081/2/3
Email: htoon@krugermm.com

• SINGAPORE

KRUGER ENGINEERING PTE LTD
No. 10 Buroh Street #06-06, West Connect Building,
Singapore 627564
Tel. +65 68631191 - Fax +65 68631151
Email: mktg@krugerasia.com

• THAILAND

KRUGER VENTILATION IND. (THAILAND) CO. LTD
30/105 Moo 1, Sinsakorn Industrial Estate,
Chetsadawithi Road, Khok Kham Mueng, Samuthsakorn 74000, Thailand
Tel. +662 1050399 - Fax + 662 1050370-2
Email: mktg@kruger.co.th

• AUSTRALIA

S&P-KRUGER AUSTRALIA PTY LTD
2 Cunningham St, Moorebank N.S.W. 2170
Tel. +61 2-98227747
Fax. +61 2-98227757
Email: info@sandpkruger.com.au

• CHINA (GUANGZHOU)

GUANGZHOU KRUGER VENTILATION CO. LTD
No. 9 Huahui Road, Huashan, Huadu,
Guangzhou, P.R. China 510880
Tel. +86 20-66356635 - Fax +86 20-86786001/86786500
Email: gzkruiger@krugergz.com

• CHINA (TIANJIN)

TIANJIN KRUGER VENTILATION CO. LTD
No.168 Anyuan Road, Jingjin Science and Technology Park
Wuqing District, Tianjin, China
Tel. +86 22-22143480/3481 - Fax +86 22-22143482
Email: krugertj@krugertj.com

• DUBAI

KRUGER VENTILATION INDUSTRIES, GULF BRANCH
Jebel Ali Free Zone Area (JAFZA) P.O. Box No. 262949, Dubai, UAE
Tel. +971 4 8819188/8832017
Fax. +971 4 8832018
Email: johncs@krugerasia.com

• INDIA

KRUGER VENTILATION INDUSTRIES (INDIA) PVT LTD
Kruger Centre, Mumbai-Nasik Highway,
Kalamgaon, Shahapur, Thane 421601, Maharashtra, India
Tel. +91 9960558899/9975577211 - Fax +91 2527 240075
Email: sales@krugerindia.com

• INDONESIA

P.T. KRUGER VENTILATION INDONESIA
JL. Teuku Umar No.20,
Karawaci - Tangerang 15115, Indonesia
Tel. +62 21-5512288/5513557 - Fax +62 21-5513502
Email: mktg@krugerindo.co.id

• MALAYSIA

KRUVENT INDUSTRIES (M) SDN BHD
Lot 850, Jalan Subang 7, Taman Perindustrian Subang,
47500, Subang Jaya, Selangor D.E.
Tel. +603 80743399 - Fax +603 80743388
Email: mktg@kruger.com.my

• PHILIPPINES

KRUGER M&E INDUSTRIES CORPORATION
FAP1 Compound, E. Rodriguez Ave.
Tunasan, Muntinlupa City 1773, Philippines
Tel. +63 2-8622892/4/6/7, 5534059 - Fax +63 2-8622891
Email: mktg@krugerp.net

• TAIPEI

KRUGER VENTILATION (TAIWAN) CO. LTD
No. 157, Ping-an Rd, Hengfeng Village,
Dayuan Shiang Taoyuan County 337, Taiwan
Tel. +886 3-3859119 - Fax +886 3-3859118
Email: sales@krugertwn.com.tw

• VIETNAM

KRUGER VENTILATION INDUSTRIES (VIETNAM) CO. LTD
Lot A7. 2-4, C2 Road, Thanh Thanh Cong IZ,
Trang Bang Dist. Tay Ninh Province, Vietnam
Tel. +84-276 3585200/01/02 - Fax +84-276 3585199
Email: mktg@krugervn.com

Kruger Ventilation (Taiwan) Co.,Ltd

No. 157, Ping-an Rd, Hengfeng Village,
Dayuan Shiang Taoyuan County 337, Taiwan
Tel. +886 3-3859119 - Fax +886 3-3859118
Email: sales@krugertwn.com.tw

CNo.-CAT028.E1.KTW March 2019

A member of
Soler&Palau 
Ventilation Group