

## EME420DDE WIND-DRIVEN RAIN STATIONARY LOUVER HORIZONTAL BLADE

### STANDARD CONSTRUCTION

#### FRAME

4" (102) deep, 6063T6 extruded aluminum with .081" (2.1) nominal wall thickness.

#### BLADES

6063T6 extruded aluminum .063" (1.6) nominal wall thickness. Double drainable blades are sightproof.

#### SCREEN

5/8" x .040" (16 x 1) expanded flattened aluminum bird screen in removable frame. Screen adds approximately 1/2" (13) to louver depth.

#### FINISH

Mill.

#### MINIMUM SIZE

12"w x 6"h (305 x 153).

#### APPROXIMATE SHIPPING WEIGHT

7 lbs. per sq. ft. (34.2 kg/m<sup>2</sup>)

#### MAXIMUM FACTORY ASSEMBLY SIZE

Shall be 75 sq. ft. (7m<sup>2</sup>) per section. Single sections shall not exceed 120" x 90"h (3048 x 2286) or 90"w x 120"h (2286 x 3048).

Louvers larger than the maximum single section size will require field assembly of smaller sections.

#### SUPPORTS

Louvers may be provided with rear mounted blade supports that increase overall louver depth depending on louver size, assembly configuration or windload.

Consult Ruskin for additional information.

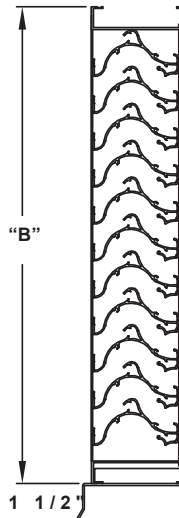
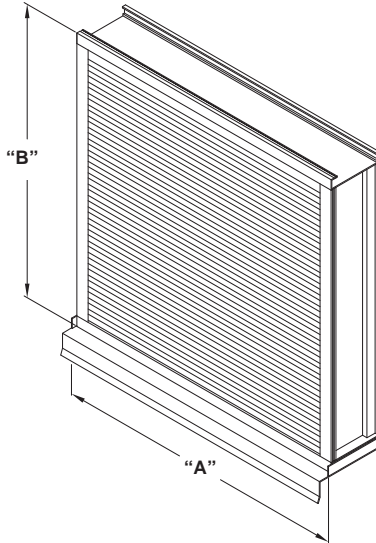

### FEATURES

- Horizontal architectural blades minimize the penetration of wind-driven rain, reducing damage and additional operating expenses.
- AMCA certified wind-driven rain results.
- Published performance ratings based on testing in accordance with AMCA Publication 511.
- 40% Free Area.
- AMCA 540 Listed (Enhanced Protection)

### VARIATIONS

- Extended sill.
- Hinged frame.
- Front or rear security bars.
- Filter racks.
- Installation angles.
- A variety of bird and insect screens.

#### Finishes:

- Prime coat.
- Baked enamel (modified fluoropolymer).
- Epoxy
- Pearledize 50 & 70.
- Kynar.
- Clear and color anodize.

Consult Ruskin for other special requirements.

### FRAME CONSTRUCTION OPTIONS

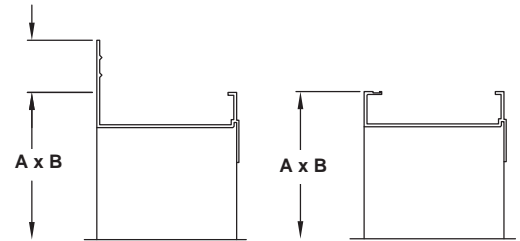

INTEGRAL FLANGE

STANDARD

### NOTES:

1. Dimensions in inches, parenthesis ( ) indicate millimeters.
2. Units furnished 1/4" (6) smaller than given opening dimensions.

Please reference our website [www.ruskin.com](http://www.ruskin.com) for up to date LEED® information

TAG	QTY.	SIZE		FRAME	VARIATIONS
		A*-WIDE	B*-HIGH		
PROJECT ARCH./ENGR. REPRESENTATIVE			LOCATION CONTRACTOR DATE		

# WATER PENETRATION GRAPH

Test size 48" x 48" (1219 x 1219)

Beginning point of water penetration at .01 oz./sq. ft. is above 1067 fpm (325 m/min.)

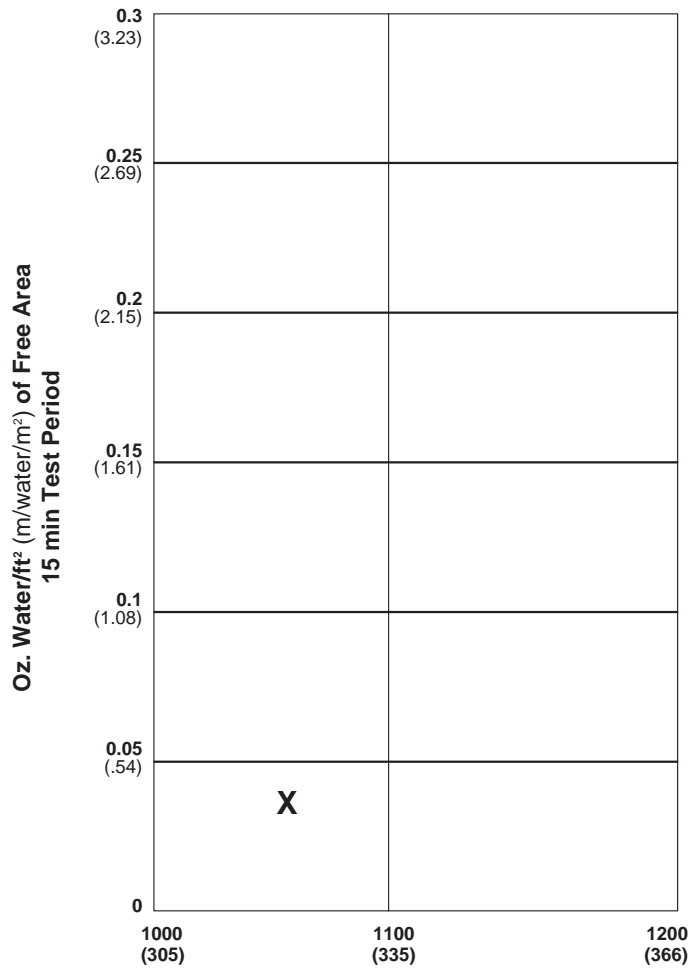

**IMPACT RESISTANT LOUVER**  
Enhanced Protection Level E

See www.AMCA.org for all certified or listed products

This label does not signify AMCA airflow performance certification.



Ruskin Company certifies that the EME420DDE is licensed to bear the AMCA Seal. The ratings shown are based on tests and procedures performed in accordance with AMCA Publication 511 and comply with the requirements of the AMCA Certified Ratings Program. The AMCA Certified Ratings Seal applies to air performance ratings, water penetration ratings, and wind driven rain ratings only.

## PRESSURE DROP

Pressure Drop testing performed on 48" x 48" (1219 x 1219) unit.

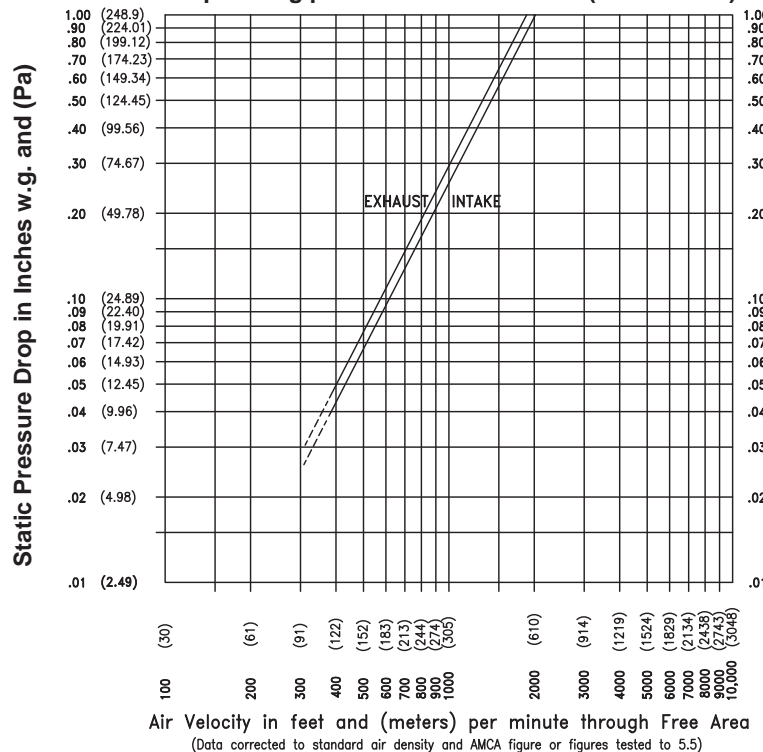

Ratings do not include the effect of a bird or insect screen.

## FREE AREA GUIDE

Free Area Guide shows free area in ft<sup>2</sup> and m<sup>2</sup> for various sizes of EME420DDE.  
Width – Inches and Meters

Height	12	18	24	30	36	42	48	54	60	66	72	78	84	90	96	102	108	114	120
	0.30	0.46	0.61	0.76	0.91	1.07	1.22	1.37	1.52	1.68	1.83	1.98	2.13	2.29	2.44	2.59	2.74	2.90	3.05
12	0.30	0.49	0.67	0.86	1.04	1.23	1.42	1.60	1.79	1.97	2.16	2.34	2.53	2.71	2.90	3.08	3.27	3.45	3.64
0.30	0.03	0.05	0.06	0.08	0.10	0.11	0.13	0.15	0.17	0.18	0.20	0.22	0.23	0.25	0.27	0.29	0.30	0.32	0.34
18	0.42	0.71	1.00	1.29	1.58	1.87	2.16	2.45	2.74	3.03	3.32	3.61	3.90	4.19	4.48	4.77	5.06	5.35	5.64
0.46	0.04	0.07	0.09	0.12	0.15	0.17	0.20	0.23	0.25	0.28	0.31	0.34	0.36	0.39	0.42	0.44	0.47	0.50	0.52
24	0.58	0.97	1.36	1.76	2.15	2.55	2.94	3.34	3.73	4.12	4.52	4.91	5.31	5.70	6.10	6.49	6.89	7.28	7.67
0.61	0.05	0.09	0.13	0.16	0.20	0.24	0.27	0.31	0.35	0.38	0.42	0.46	0.49	0.53	0.57	0.60	0.64	0.68	0.71
30	0.78	1.32	1.85	2.39	2.92	3.46	3.99	4.53	5.06	5.60	6.13	6.67	7.21	7.74	8.28	8.81	9.35	9.88	10.42
0.76	0.07	0.12	0.17	0.22	0.27	0.32	0.37	0.42	0.47	0.52	0.57	0.62	0.67	0.72	0.77	0.82	0.87	0.92	0.97
36	0.93	1.57	2.21	2.85	3.49	4.13	4.77	5.41	6.05	6.69	7.33	7.97	8.61	9.25	9.89	10.53	11.17	11.81	12.45
0.91	0.09	0.15	0.21	0.27	0.32	0.38	0.44	0.50	0.56	0.62	0.68	0.74	0.80	0.86	0.92	0.98	1.04	1.10	1.16
42	1.09	1.83	2.58	3.32	4.06	4.81	5.55	6.30	7.04	7.79	8.53	9.28	10.02	10.77	11.51	12.26	13.00	13.75	14.49
1.07	0.04	0.07	0.10	0.13	0.16	0.19	0.22	0.25	0.28	0.31	0.34	0.37	0.39	0.42	0.45	0.48	0.51	0.54	0.57
48	1.24	2.09	2.94	3.79	4.64	5.49	6.33	7.18	8.03	8.88	9.73	10.58	11.43	12.28	13.13	13.98	14.83	15.68	16.53
1.22	0.12	0.19	0.27	0.35	0.43	0.51	0.59	0.67	0.75	0.83	0.91	0.98	1.06	1.14	1.22	1.30	1.38	1.46	1.54
54	1.44	2.43	3.42	4.42	5.41	6.40	7.39	8.38	9.37	10.36	11.35	12.34	13.33	14.32	15.31	16.30	17.29	18.28	19.27
1.37	0.13	0.23	0.32	0.41	0.50	0.59	0.69	0.78	0.87	0.96	1.06	1.15	1.24	1.33	1.42	1.52	1.61	1.70	1.79
60	1.60	2.69	3.79	4.88	5.98	7.07	8.17	9.26	10.36	11.45	12.55	13.64	14.74	15.83	16.93	18.02	19.12	20.21	21.31
1.52	0.15	0.25	0.35	0.45	0.56	0.66	0.76	0.86	0.96	1.06	1.17	1.27	1.37	1.47	1.57	1.68	1.78	1.88	1.98
66	1.75	2.95	4.15	5.35	6.55	7.75	8.95	10.15	11.35	12.55	13.75	14.95	16.14	17.34	18.54	19.74	20.94	22.14	23.34
1.68	0.16	0.27	0.39	0.50	0.61	0.72	0.83	0.94	1.06	1.17	1.28	1.39	1.50	1.61	1.72	1.84	1.95	2.06	2.17
72	1.96	3.30	4.64	5.98	7.32	8.66	10.00	11.34	12.68	14.02	15.36	16.70	18.04	19.38	20.72	22.06	23.40	24.75	26.09
1.83	0.18	0.31	0.43	0.56	0.68	0.81	0.93	1.05	1.18	1.30	1.43	1.55	1.68	1.80	1.93	2.05	2.18	2.30	2.43
78	2.11	3.55	5.00	6.44	7.89	9.33	10.78	12.22	13.67	15.11	16.56	18.01	19.45	20.90	22.34	23.79	25.23	26.68	28.12
1.98	0.20	0.33	0.46	0.60	0.73	0.87	1.00	1.14	1.27	1.41	1.54	1.67	1.81	1.94	2.08	2.21	2.35	2.48	2.62
84	2.26	3.81	5.36	6.91	8.46	10.01	11.56	13.11	14.66	16.21	17.76	19.31	20.86	22.41	23.96	25.51	27.06	28.61	30.16
2.13	0.21	0.35	0.50	0.64	0.79	0.93	1.08	1.22	1.36	1.51	1.65	1.80	1.94	2.08	2.23	2.37	2.52	2.66	2.80
90	2.47	4.16	5.85	7.54	9.23	10.92	12.61	14.30	15.99	17.68	19.37	21.07	22.76	24.45	26.14	27.83	29.52	31.21	32.90
2.29	0.23	0.39	0.54	0.70	0.86	1.02	1.17	1.33	1.49	1.64	1.80	1.96	2.12	2.27	2.43	2.59	2.75	2.90	3.06
96	2.62	4.41	6.21	8.01	9.80	11.60	13.39	15.19	16.98	18.78	20.57	22.37	24.16	25.96	27.76	29.55	31.35	33.14	34.94
2.44	0.24	0.41	0.58	0.74	0.91	1.08	1.25	1.41	1.58	1.75	1.91	2.08	2.25	2.41	2.58	2.75	2.92	3.08	3.25
102	2.77	4.67	6.57	8.47	10.37	12.27	14.17	16.07	17.97	19.87	21.77	23.67	25.57	27.47	29.37	31.27	33.17	35.07	36.97
2.59	0.26	0.43	0.61	0.79	0.96	1.14	1.32	1.49	1.67	1.85	2.02	2.20	2.38	2.56	2.73	2.91	3.09	3.26	3.44
108	2.98	5.02	7.06	9.10	11.14	13.18	15.22	17.26	19.31	21.35	23.39	25.43	27.47	29.51	31.55	33.59	35.64	37.68	39.72
2.74	0.28	0.47	0.66	0.85	1.04	1.23	1.42	1.61	1.80	1.99	2.18	2.36	2.55	2.74	2.93	3.12	3.31	3.50	3.69
114	3.13	5.28	7.42	9.57	11.71	13.86	16.00	18.15	20.30	22.44	24.59	26.73	28.88	31.03	33.17	35.32	37.46	39.61	41.75
2.90	0.29	0.49	0.69	0.89	1.09	1.29	1.49	1.69	1.89	2.09	2.29	2.49	2.69	2.89	3.08	3.28	3.48	3.68	3.88
120	3.28	5.53	7.78	10.03	12.28	14.53	16.78	19.04	21.29	23.54	25.79	28.04	30.29	32.54	34.79	37.04	39.29	41.54	43.79
3.05	0.31	0.51	0.72	0.93	1.14	1.35	1.56	1.77	1.98	2.19	2.40	2.61	2.82	3.03	3.24	3.44	3.65	3.86	4.07

## WIND-DRIVEN RAIN PERFORMANCE

Test size is 1m x 1m (39" x 39") core area, 1.04m x 1.12m (41" x 44") nominal. Free Area of test louver is 5.45 ft<sup>2</sup> (.51m<sup>2</sup>).

**29 mph (13 m/s) wind & 3" (76) per hour rain conditions**

Core Velocity <sub>1</sub> fpm (m/s)	Airflow cfm (m <sup>3</sup> /min)	Free Area Velocity <sub>2</sub> fpm (m/sec.)	Effectiveness Ratio	Class <sub>3</sub>
0 (0)	0 (0)	0 (0)	99.9%	A
0 (0)	0 (0)	0 (0)	99.9%	A
0 (0)	0 (0)	0 (0)	99.9%	A
283 (1.4)	3052 (86.4)	726 (221.3)	99.9%	A
376 (1.9)	4049 (114.7)	964 (293.8)	99.9%	A
464 (2.4)	4992 (141.4)	1190 (362.7)	99.1%	A
578 (2.9)	6224 (176.3)	1482 (451.9)	96.5%	B
681 (3.5)	7334 (207.7)	1746 (532.2)	93.2%	C

**50 mph (22 m/s) wind & 8" (203) per hour rain conditions**

Core Velocity <sub>1</sub> fpm (m/s)	Airflow cfm (m <sup>3</sup> /min)	Free Area Velocity <sub>2</sub> fpm (m/sec.)	Effectiveness Ratio	Class <sub>3</sub>
0 (0)	0 (0)	0 (0)	99.9%	A
101 (.5)	1084 (30.7)	259 (78.9)	99.8%	A
175 (.9)	1889 (53.5)	349 (136.9)	99.7%	A
296 (1.5)	3189 (90.3)	759 (231.3)	99.3%	A
390 (2.0)	4199 (118.9)	1000 (304.8)	98.3%	B
491 (2.5)	5289 (149.8)	1259 (383.7)	97.2%	B
567 (2.9)	6104 (172.9)	1454 (443.2)	96.0%	B
687 (3.5)	7392 (209.3)	1762 (537.1)	91.6%	C

**NOTES**

- Core area is the open area of the louver face (face area less louver frames). Core Velocity is the airflow velocity through the Core Area of the louver (1m x 1m).
- Free Area of test size is calculated per AMCA standard 500-L.
- Wind Driven Rain Penetration Classes:
 

<b>Class</b>	<b>Effectiveness</b>
A	1 to .99
B	0.989 to 0.95
C	0.949 to 0.80
D	Below 0.8
- Intake Discharge Loss Class 3  
 Discharge Loss Coefficient is calculated by dividing a louvers' actual airflow rate vs. a theoretical airflow for the opening. It provides an indication of the louvers' airflow characteristics.

**Discharge Loss Classes:**

- |              |                                   |
|--------------|-----------------------------------|
| <b>Class</b> | <b>Discharge Loss Coefficient</b> |
| 1            | 0.4 and above                     |
| 2            | 0.3 to 0.399                      |
| 3            | 0.2 to 0.299                      |
| 4            | 0.199 and below                   |

(The higher the coefficient, the less resistance to airflow.)

5. The AMCA Wind Driven Rain Test is performed in a laboratory environment and incorporates controlled wind, water and system airflow effects. In actual field installations, storms may create conditions not considered by the AMCA test. Penthouse and similar applications where wind can pass through multiple louvers in an enclosure is another condition that is not simulated by AMCA tests. These applications can create elevated water penetration rates through any louver. Because of these uncontrolled situations, it is recommended that provisions to manage water penetration through louvers be included in the building design.

# TYPICAL INSTALLATION DETAILS

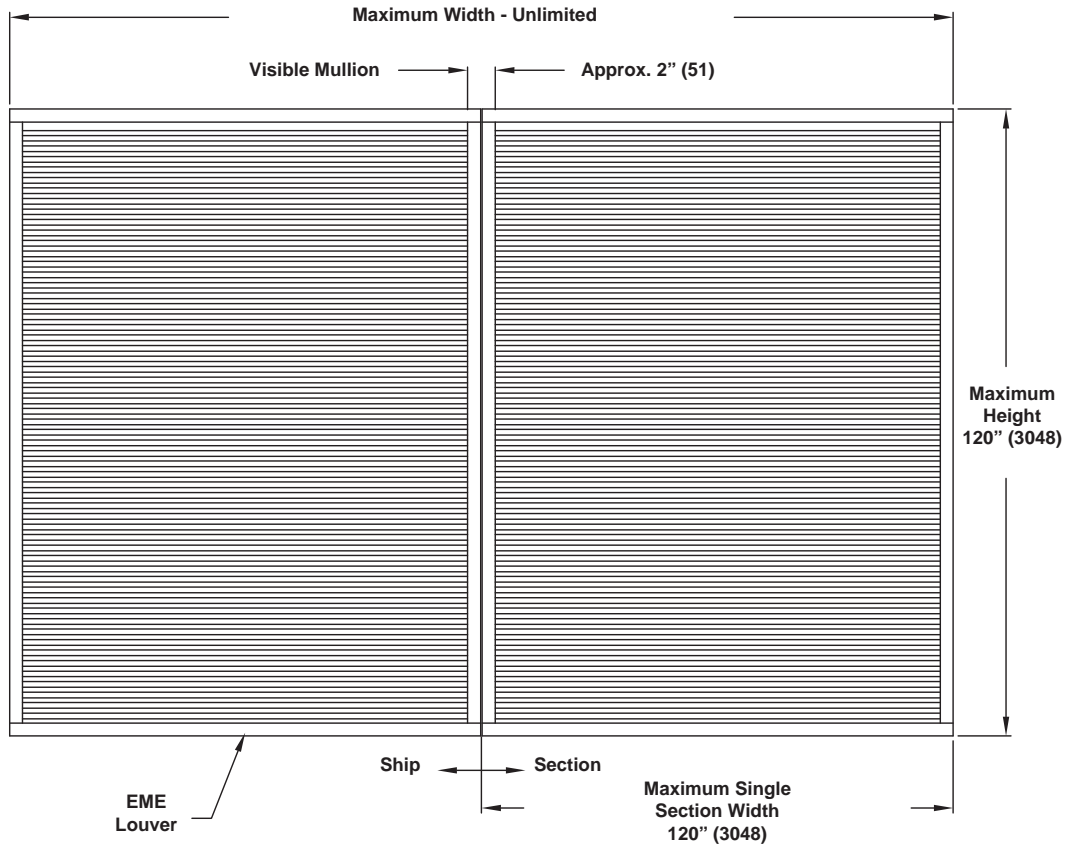

1. Reference separate Installation Instruction sheets for installation details. It is the responsibility of the installing contractor to properly install the louvers per the appropriate detail.

2. Louvers wider than the maximum single section width will be shipped in multiple sections and will require field assembly. Field assembly is not by Ruskin.

