

BCZ Series

DOUBLE INLET CENTRIFUGAL FAN

With Backward Inclined Wheels



POWER VENTILATOR
45GD



封面風機顏色僅供參考

Ventilation Performance Laboratory

世界級的認證

因為有您的支持
陽鼎實現了大家的夢！
我們擁有...



常溫風機性能測試設備 Fan Performance Testing Facility

- 測試標準 (Standards)
- AMCA 210-85
 - BS 848-1
 - ISO 5801
 - DIN 24163-2

消音箱/消音百葉測試設備 Silencer / Acoustical Louver Testing Facility

- 測試標準 (Standards)
- ASTM-E477
 - ISO 7235

風門、百葉壓損測試設備 Louver Pressure Drop Testing Facility

- 測試標準 (Standards)
- AMCA 500



排煙風門洩漏測試設備 Smoke Damper Leakage Testing Facility

- 測試標準 (Standards)
- AMCA 500
 - ISO 10294
 - UL 555S
 - GB 15930

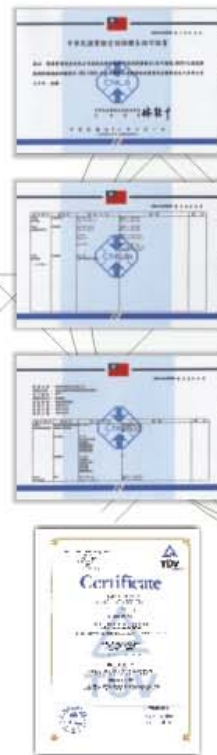

隧道通風機振動/ 推力測試設備 Jet Fan Thrust Testing Facility

- 測試標準 (Standards)
- ISO 13350
 - BS 848-10



通風設備性能與耐溫測試實驗室



全響室迴風出口
Exhaust Duct exit of Reverberant



流量噴嘴
Multiple Nozzles for Flow Measurement



全響室
Reverberant Room
360° 旋轉錄音器
360° Routing Microphone in Reverberant



整流裝置
Flow Straightener



全響室迴風消音器
Silencer in Exhaust Duct

測試標準：

- | | | |
|-------------|--------------|-----------|
| AMCA 210-85 | BS 7346-2 | ISO 5801 |
| AMCA 300 | BS 848-1 | ISO 7235 |
| AMCA 500 | BS 848-2 | ISO 10294 |
| AS 4429 | BS 848-10 | ISO 13350 |
| ASTM-E477 | GA 211 | UL 555 |
| ASHRAE 149 | GB 15930 | UL 555S |
| DIN 24163-2 | prEN 12101-3 | |



防火風門測試設備 Fire Damper Testing Facility

- 測試標準 (Standards)
- UL 555





BCZ Series



DOUBLE INLET CENTRIFUGAL FAN with Backward Inclined Wheels

Low and Medium pressure high efficiency centrifugal fan



Flowtech Co., Ltd. Certifies that Model BCZ shown on pages 14-32 and 34-52 is licensed to bear the AMCA Seal. The ratings shown are based on tests and procedures performed in accordance with AMCA Publication 211 and AMCA Publication 311 and comply with requirements of the AMCA Certified Ratings Program.



POWER VENTILATOR
45GD

BCZ Series are listed for electrical
(UL/cUL 705) File no. E323432

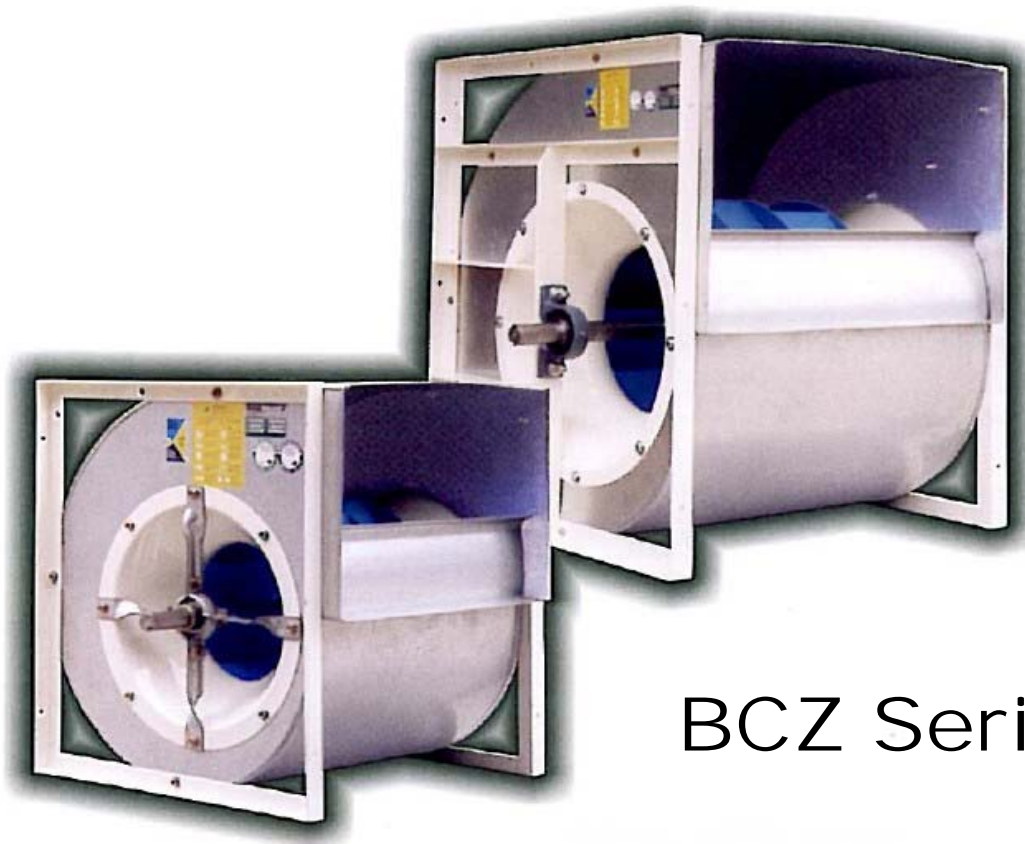

BCZ Series

風機顏色僅供參考



BCZ Series Double Inlet Centrifugal Fans – Backward wheels

The BCZ series is DWDI centrifugal fans with high efficiency non-overloading backward curved impellers. The fans are auditable for supply or extract applications in commercial, process and industrial HVAC systems. Sizes of this are in accordance with AMCA standard 99-0098-76 R20.

Type / Operating Limit

	Model 250-450	Model 250-630	Model 710-2000
Type L	I		
Type M		I	
Type H		II	I
Type V		III	II
Type X			III

Each fan type has its maximum operation speed and power due to its mechanical design.

The operating limit of BCZ series – fan type is design to meet the requirement of class I, II and III limit as defined in AMCA standard 99-2408-69.

The BCZ series is available in type L, M, H, V ,X as shown in Fig.1 :

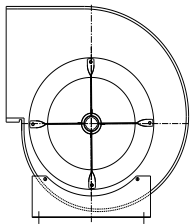

Type L This type is supplied with mounting feet and can be mounted in three different orientations. Inlet flange ‘L’ and outlet flange are supplied as standard.

Without outlet flange, with removable feet

Size : 250 to 450 Volume : 0.25 to 5.5 m3/s Total Pressure. : up to 2000Pa

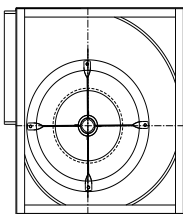

Type M This type has a frame fitted on both sides of the fan which gives better strength and rigidity and allows mounting in four different orientations.

Without outlet flange, with welded rectangular frame.

Size : 250 to 630 Volume : 0.25 to 11 m3/s Total Pressure. : up to 2000Pa

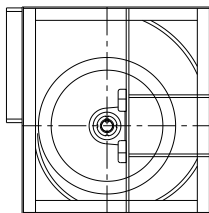

Type H This type has a welded frame giving increased stiffness and rigidity required for higher operating performance.

Without outlet flange, with welded rectangular frame.

Size : 315 to 2000 Volume : 0.35 to 110 m3/s Total Pressure. : up to 2500Pa

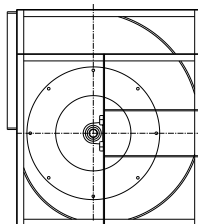

Type V This type is similar to type H but utilizes enhanced bearings to support higher load necessary for the increased performance.

Without outlet flange, with welded rectangular frame.

Size : 315 to 2000 Volume : 0.35 to 160 m3/s Total Pressure. : up to 3000Pa

Fig.1

The type “X” is non-standard , for more information , please consult Flowtech co., Ltd



Designation ,Formula signs

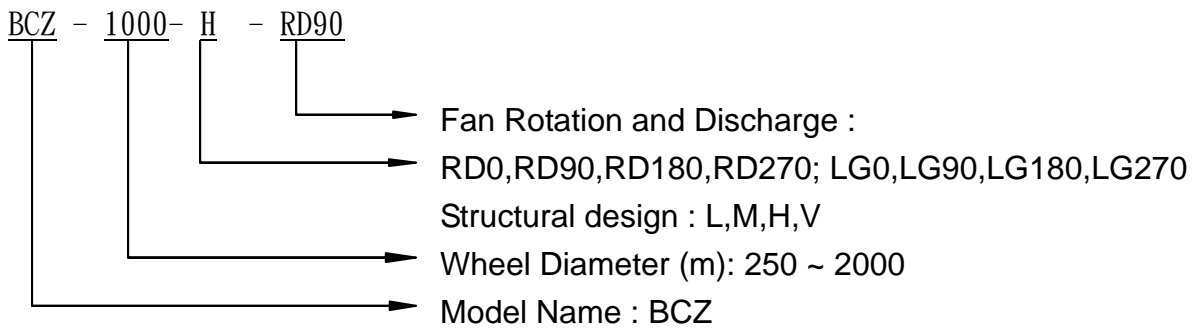

BCZ Twin Fan

BCZ series are also available in twin fan version, with two double inlet fans mounted on the same shaft. To Select for twin fans, use the curve of single fan with the following factors :

- Volume-----x 2
- Absorbed Power -----x 2.15
- Speed -----x 1.05
- Noise -----+ 3 dB

This series is available in type G₂ L (250-400), G₂ M (250-500), G₂ H (355-1000)
 Performances of Twin fans are not AMCA licensed.

TECHNICAL SPECIFICATION



■ Wheel

The Wheel of BCZ series is made of mild steel backward curved blades with polyester powder coating finish and fully welded. The material of wheel also made of stainless steel or aluminum. All wheels are statically and dynamically balanced to ISO1940 and AMCA 204/3-G2.5 standards.



■ Shaped Inlets (Inletcone)

The aerodynamically shaped inlets are bolted in and guarantee a perfect inlet stream onto the impeller. The inletcone is made of galvanized sheet metal or mild steel or aluminum.



■ **Housing**

For all sizes except 1120 and above, the housing is manufactured in galvanized sheet steel with the housing fixed to the side plates in "Pittsburg lock" form system. Housings for 1250-2000 are manufactured in mild steel finished with polyester powder coating.

■ **Frame**



The frame is manufactured with galvanized angular bars for type "M". For type "H" and "V", They are manufactured with sections of steel and finished with polyester powder coating.

■ **Shaft**

Shafts are manufactured from C45 carbon steel using an automatic process for positioning and cutting of the keyways. All dimensional I tolerances of the shaft are fully checked to ensure a precision fit and then coated with an anti-corrosion varnish after assembly. Both shaft ends have as a standard feature diameters complying with ISO286. Shafts are sized to operate 20% or more below the first critical speed for each class of duty.

■ **Bearings**

Bearings used are either deep groove ball bearing type with an eccentric locking collar or an adapter sleeve, or spherical roller bearings type sealed at both sides for different duty application. Bearing are selected for continuous operation and ample size for best possible operating results. They are selected for a basic rating fatigue life (L-10) per AFBMA Standards in excess of 40,000 hours at maximum operating speed for each pressure class. L-10 is the life associated with 90% reliability of a bearing.,

<p>Fan Type L , M</p> 	<p>For fan type "L" and "M" are use single row, deep groove, self-aligning ball bearings with an eccentric locking collar. They are mounted in a rubber housing and sealed at both sides for light duty application. (light Duty)</p>
<p>Fan Type H</p> 	<p>For fan type "H" use single row sealed ball bearings, locked on the shaft with conical sleeve and mounted inside cast-iron blocks ,with grease points, bolted to the side-frames.(Medium Duty)</p>
<p>Fan Type V</p> 	<p>For type "V", Bearings are mounted on cast iron supports with grease points. According to the fan duty and size, bearings use double-row ball type with conical sleeve inside split block housings.(Heavy Duty)</p>

The bearings are lubricated for life and maintenance-free. If re-lubrication is necessary, it is recommended to use a lithium base grease suitable for all temperatures within the operational limits.



■ **Balancing Quality**

All wheels are statically and dynamically balanced to ISO1940 and AMCA 204-G2.5 standards.

All fans after assembly are trim-balanced to ISO1940 and AMCA 204-G2.5 standard.

Clean room application fans with balancing grade of G1.0 are available upon request.

■ **Special paint & corrosion resistant coatings** : Consult Flowtech office.

OPTIONAL ACCESSORIES

■ **Casing Drain**

This option is available when using fans exposed to the atmosphere or operating in high humidity conditions.

■ **Outlet Flanges**

Outlet flanges are in accordance with DIN 24193 sheet 2 and available upon request.

■ **Guards**

Inlet guards, discharge guards and non-drive end shaft guards are available on request.

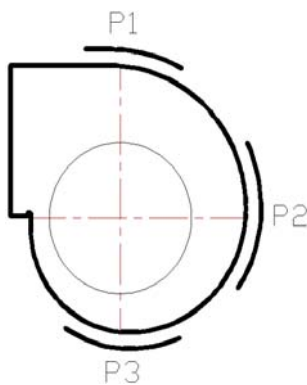

■ **Inspection Doors**

The inspection door can be supplied upon request.

It can be supplied in one of the three positions(P1, P2, & P3).

■ **Stainless steel fan shafts** are available on fan sizes for applications where standard carbon steel shafts may exhibit excessive corrosion or heat stress.

■ **Split housings.** Type H, V fan can be furnished with horizontal split housings to facilitate wheel removal at additional cost. Housing splits are caulked and bolted when fan is shipped assembled.

■ **Spring Isolation Bases and Spring Isolators**

Flowtech offers a complete line of spring isolation bases with free standing or housed spring isolators. Base are available with height saving brackets for minimal fan and base height. Inertia bases built to accept poured concrete are also available.

■ **Ignition protected versions**

Ignition protected versions can be built on request, with inletcones made of aluminum, copper or with copper rubbing stripes on the edge of the inletcones. Please contact Flowtech for selection and detail.

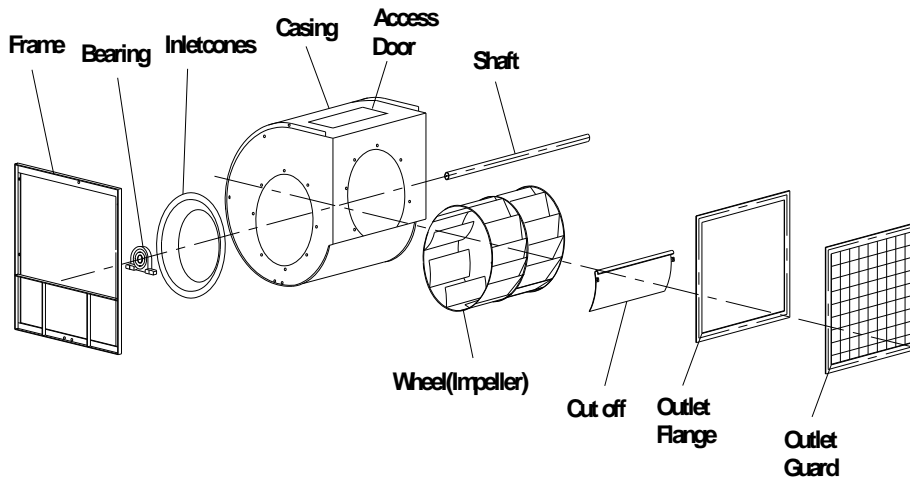

Fan layout drawing

Fan Rotation and Discharge

The rotation and discharge of the fan is in accordance with AMCA standard 99-2406-03.

The direction of rotation is determined from the drive side of fan [refer Fig.2]: -

CW -clockwise rotation :

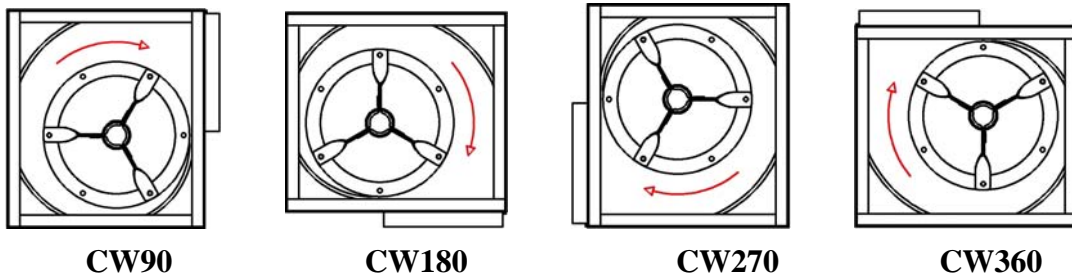

CCW -counter-clockwise rotation :

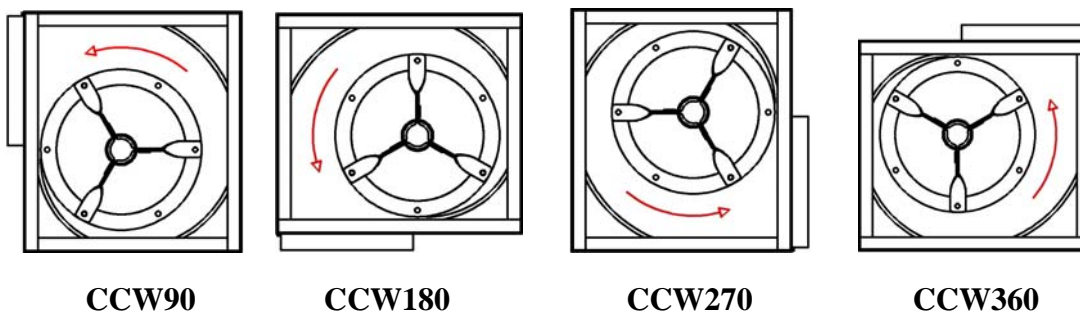

Fig.2-Fan rotation and discharge



Motor Position

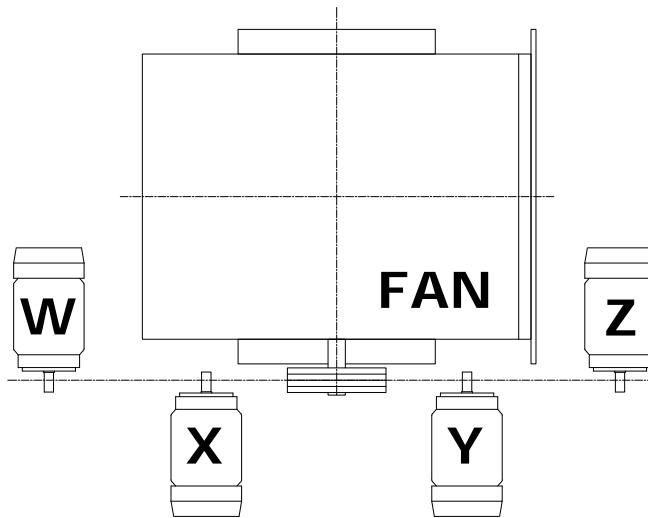

Fig. 3 – Motor Position

The position of the motor for belt drive centrifugal fan is in accordance with AMCA standard 99-2407-03.

Location of motor is determined by Facing the drive side of fan and Designating the position by letters W, X , Y or Z[refer Fig. 3]

Motor Selection

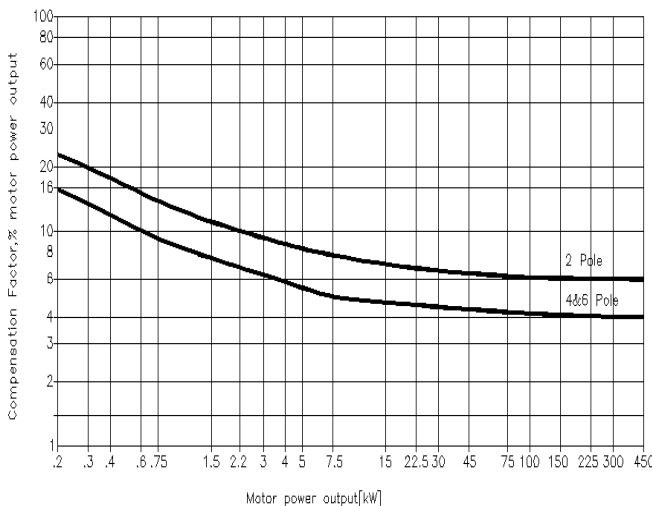

Fig.4-Recommended for motor compensation

The power curve shown on each Performance curve represents the Absorbed power at the shaft of the fan measured in kW.

To determine the power of the motor to be installed, a correction Factors as shown in fig. 4 should be applied to compensate for transmission losses.

For conversion to horsepower (HP), use multiplying factor 1.34.



Dynamic Pressure

The dynamic pressure and outlet air velocity shown on each curve are both calculated on the full air discharge area i.e. ducted outlet conditions.

With free outlet conditions the velocity pressure is higher. To determine this value multiply the velocity Pressure of the ducted outlet obtained from the fan curve by the following correction factor “K”
Fan performances calculated with this correction factors are not licensed by AMCA.

$$[K = 1.65]$$

Performance

The performance data show on each diagram has been tested and measured in accordance to AMCA Standard 210 – Fig 12 – installation type B (free inlet and ducted outlet condition).

Ratings are referred to the standard air density with the total pressure as function of the air volume, using logarithmic scales.

It is essential that, the same installation type and test standards are used at all times, when comparing fan performances.

Noise

The noise level shown on each diagram refer to the sound power “A-weighted” and the data on the inlet side has been measured in accordance with AMCA Standard 300 figure 2 – installation Type “B”.

The noise level of the fan determined as follows :

- Inlet Sound power level (“A” scale) : L_{wiA} as catalogue [2005.4.12 新增]
- Inlet Octave band spectrum : L_{wi} as catalogue [2005.4.12 新增]
- Sound pressure level :
 - Free field : $L_p(A) = L_{wA} - (20\log_{10}d) - 11$
 - Room conditions : $L_p(A) = L_{wA} - (20\log_{10}d) - 7$

Where d : distance between the fan and the microphone in m .

Sound power

Sound power data is charted for the full range of speed and percent of fan flow rate (%POF) for each unit size. The %POF is a convenient way to indicate the operating point (pressure and fan flow rate, cmm) for given fan speed. To calculate %POF for a given fan size, use the equation shown below. Because the constant K in the equation changes for each fan size, use the equation which is located on the specific performance page.

$$\%POF = \frac{CMM \times 3531.5}{RPM \times K}$$

Use the following to calculate sound power data for a specific Fan speed and %POF:

1. Determine the eight sound power levels for the specified %POF using the higher Fan RPM shown.
2. Determine the eight sound power levels for the specified %POF using lower Fan RPM shown.
3. Interpolate between the higher and lower sound power levels using the specified RPM.



Minimum diameter recommended for the smallest transmission pulley.

	Size	355			400			450		
		L/M	H	V	L/M	H	V	L/M	H	V
Rating power	4	85								
	5.5	100	90		112			112		
	7.5	112	112	100	140	100		125	112	
	11		125	112		132		180	140	
	15			118		180	118		180	125
	18.5						140			140
	22						150			160
	30									212

	Size	500			560			630		
		M	H	V	M	H	V	M	H	V
Rating power	5.5	125								
	7.5	132	132		140			140		
	11	160	150		180	150		180	150	
	15		200	140	224	200		250	200	
	18.5			140		224	150		250	180
	22			150			160			180
	30			200			212			236
	37									280

	Size	710		800		900		1000	
		H	V	H	V	H	V	H	V
Rating power	11								
	15	224		200					
	18.5	250		250		160			
	22	315	180	280	180	180		180	
	30		224		212	250	212	236	212
	37		250		250		224	315	224
	45						224		224
	55						250		250
	75						280		280



BCZ Series



Operational Limits - "BCZ"

			250	280	315	355	400	450	500	560	630	710	800	900	1000	1120	1250	1400	
Maximum Absorbed Power	L-M	kW	2.5	2.5	3	5	6	8	10	12.5	12.5								
	H	kW	5	6	8	10	12.5	15	20	25	30	20	25	30	30	50	60	60	
	V	kW			10	12.5	15	20	25	30	50	40	50	60	80	100	125	150	
	X	kW										50	80	80	100	150	200	200	
Maximum Fan Speed	L-M	rpm	4200	3400	3200	3000	2700	2400	2150	1900	1600								
	H	rpm	5500	4900	4100	3900	3400	3100	2800	2500	2100	1450	1300	1150	1000	950	825	720	
	V	rpm			4500	4150	3700	3300	3000	2650	2400	1850	1650	1500	1300	1200	1050	950	
	X	rpm										2100	1900	1650	1500	1350	1200	1070	
Air Temperature Min.-20° C	L-M	Max. °C	85	85	85	85	85	85	85	85	85								
	H-V	Max. °C	100	100	100	100	100	100	100	100	100	100	100	100	100	100	100	100	100
Wheel	Diameter	mm	250	280	315	355	400	450	500	560	630	710	800	900	1000	1120	1250	1400	
	Weight	kg	4.8	6	7.5	10.7	13.3	19.5	24.7	30	39	59	94	115	148	250	297	340	
	$J=PD^2/4$	Kgm ²	0.051	0.08	0.129	0.231	0.501	0.676	1.056	1.61	2.63	5.05	10.2	15.9	25.2	52.1	72.1	110.4	
Fan weight	L	kg	16	22	26	37	43	59	75	92	100	148							
	M	kg	20	24	28	41	49	65	83	104	120	166							
	H	kg	26	34	40	53	67	77	97	125	154	214	276	352	426	749	1002	1356	
	V	kg									144	178	250	317	383	461	784	1030	1387

**‘BCZ’ OUTLET AREAS AND PAGE NUMBERS**

Fan Size	Outlet Width mm	Outlet Height mm	Outlet Area (Inside area) m²	PAGE NO.
250	300	250	0.0750	14
280	336	280	0.0941	15
315	378	315	0.1191	16
355	500	355	0.1775	17
400	560	400	0.2240	18
450	640	450	0.2880	19
500	700	500	0.3500	20
560	790	560	0.4424	21
630	890	630	0.5607	22
710	1000	710	0.7100	23
800	1130	800	0.9040	24
900	1270	900	1.1430	25
1000	1400	1000	1.4000	26
1120	1580	1120	1.7696	27
1250	1770	1250	2.2125	28
1400	1980	1400	2.7720	29
1600	2260	1600	3.6160	30
1800	2550	1800	4.5900	31
2000	2850	2000	5.7000	32



Examples of selection

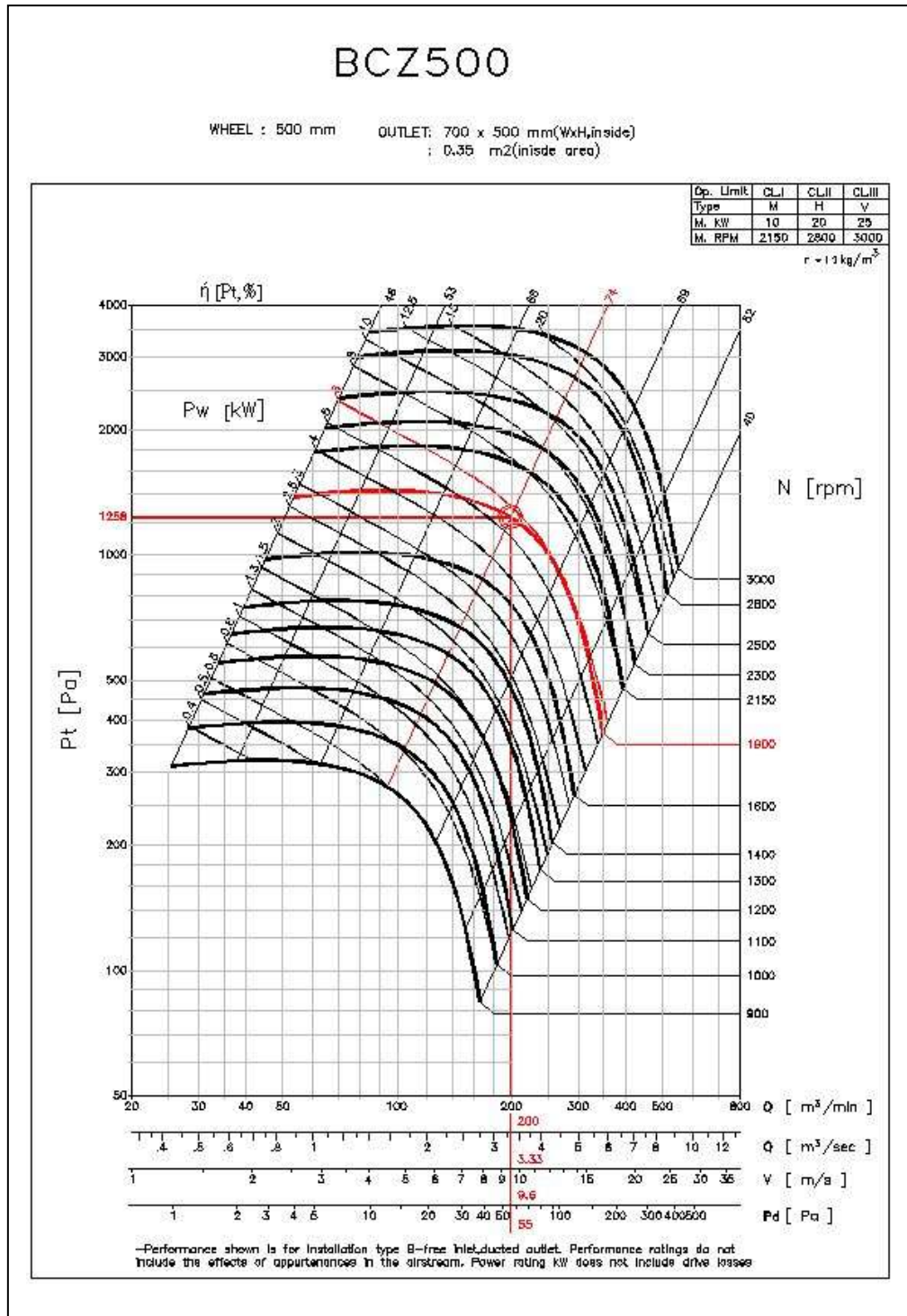

Air Volume Q = 3.33 cms Fan Speed N = 1900 rpm

Outlet Velocity V = 9.6 m/s Absorbed Power Pw = 6 kW

Dynamic Pressure Pd = 55 Pa Total Efficiency η = 74 %

Total Pressure Pt = 1258 Pa



BCZ250



WHEEL : 250 mm OUTLET: 300 x 250 mm(WxH,inside)
 : 0.075 m²(inside area)

Op. Limit	CL.I	CL.II
Type	L-M	H
M. kW	2.5	5
M. RPM	4200	5000

FEG71 r = 1.2 kg/m³

□ Type L-M ■ Type H

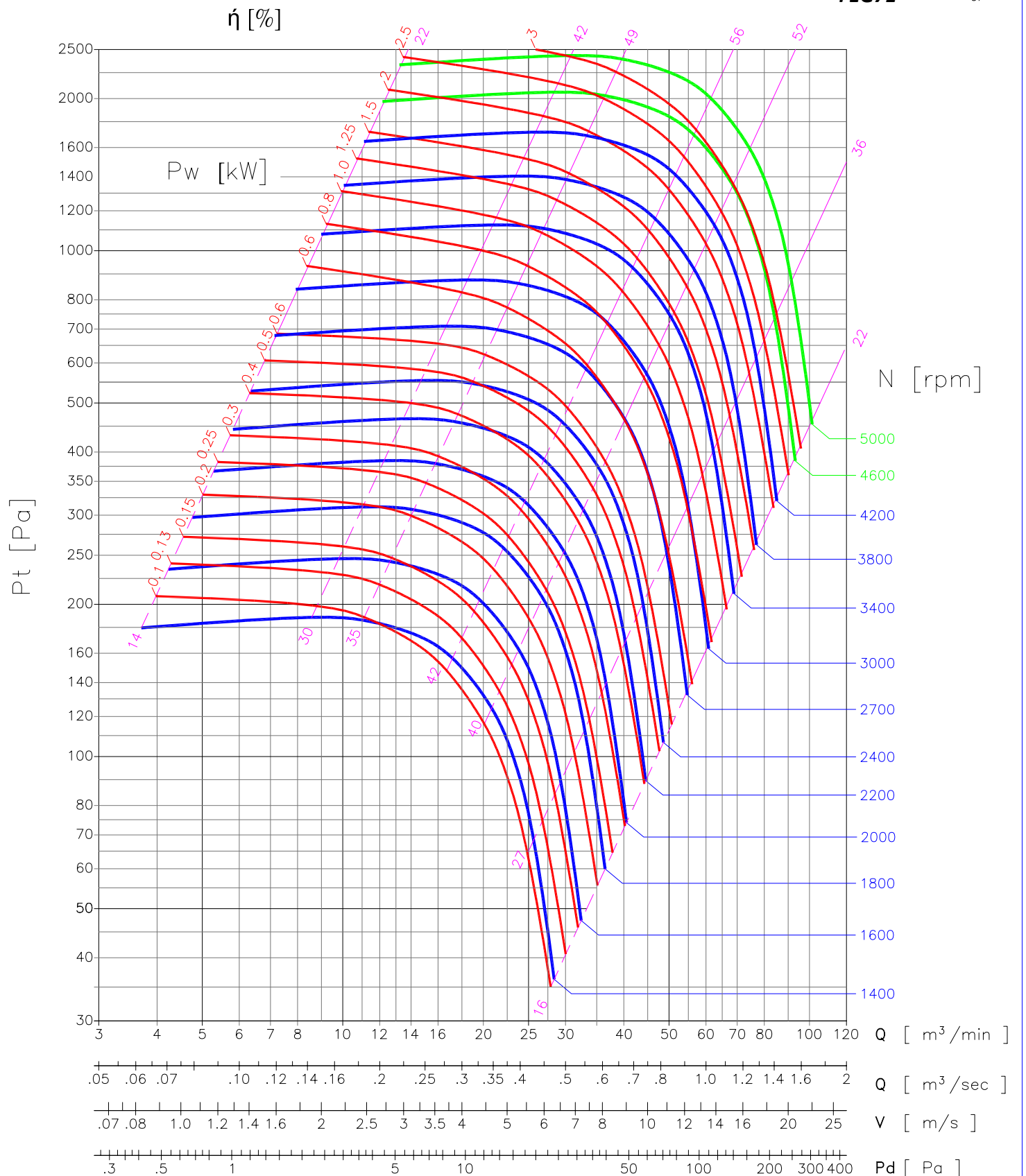

-Performance certified is for installation type B - Free inlet, Ducted outlet. Performance ratings do not include the effects of appurtenances (accessories). Power rating kW does not include transmission losses.

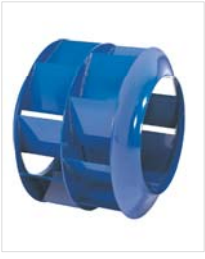

BCZ280

WHEEL : 280 mm OUTLET: 336 x 280 mm(WxH,inside)
 : 0.0941 m²(inside area)

Op. Limit	CL.I	CL.II
Type	L-M	H
M. kW	2.5	6
M. RPM	3400	4900

□ Type L-M ■ Type H

FEG67 $r = 1.2 \text{ kg/m}^3$

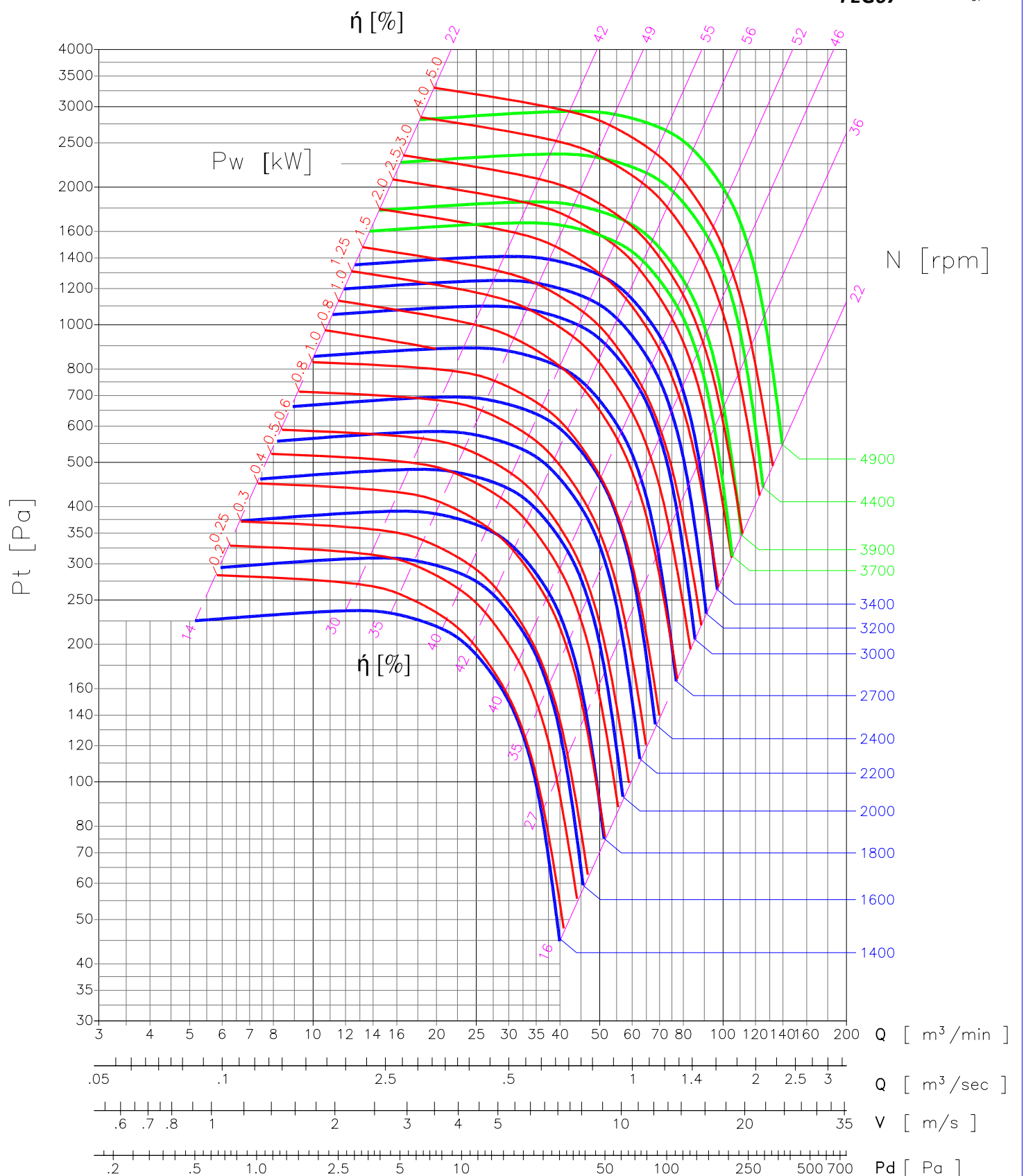

-Performance certified is for installation type B - Free inlet, Ducted outlet. Performance ratings do not include the effects of appurtenances (accessories). Power rating kW does not include transmission losses.

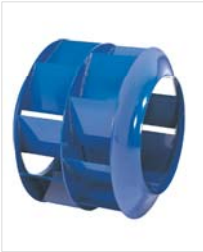

BCZ315

WHEEL : 315 mm OUTLET: 378 x 315 mm(WxH,inside)
 : 0.11927 m²(inside area)



Op. Limit	CL.I	CL.II	CL.III
Type	L-M	H	V
M. kW	3	8	10
M. RPM	3200	4100	4500

FEG67

$r = 1.2 \text{ kg/m}^3$

M-T
 H-T
 V-T

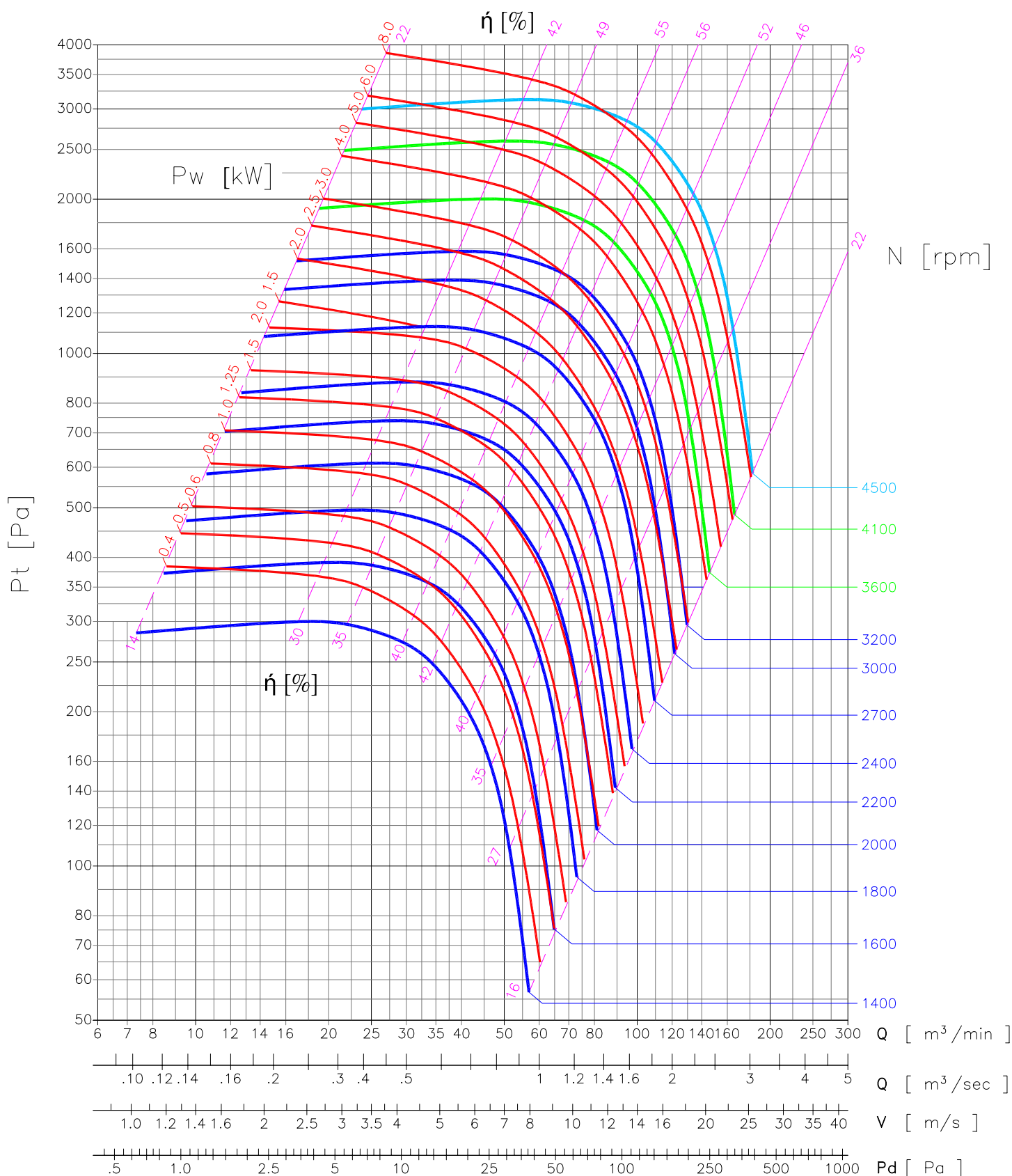

-Performance certified is for installation type B - Free inlet, Ducted outlet. Performance ratings do not include the effects of appurtenances (accessories). Power rating kW does not include transmission losses.

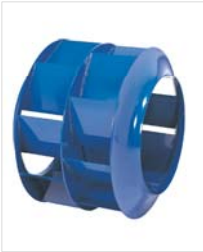

BCZ355

WHEEL : 355 mm
 OUTLET: 500 x 355 mm(WxH,inside)
 : 0.1775 m²(inside area)



Op. Limit	CL.I	CL.II	CL.III
Type	L-M	H	V
M. kW	5	10	12.5
M. RPM	3000	3900	4150

FEG85

r = 1.2 kg/m³

Type L-M
 Type H
 Type V

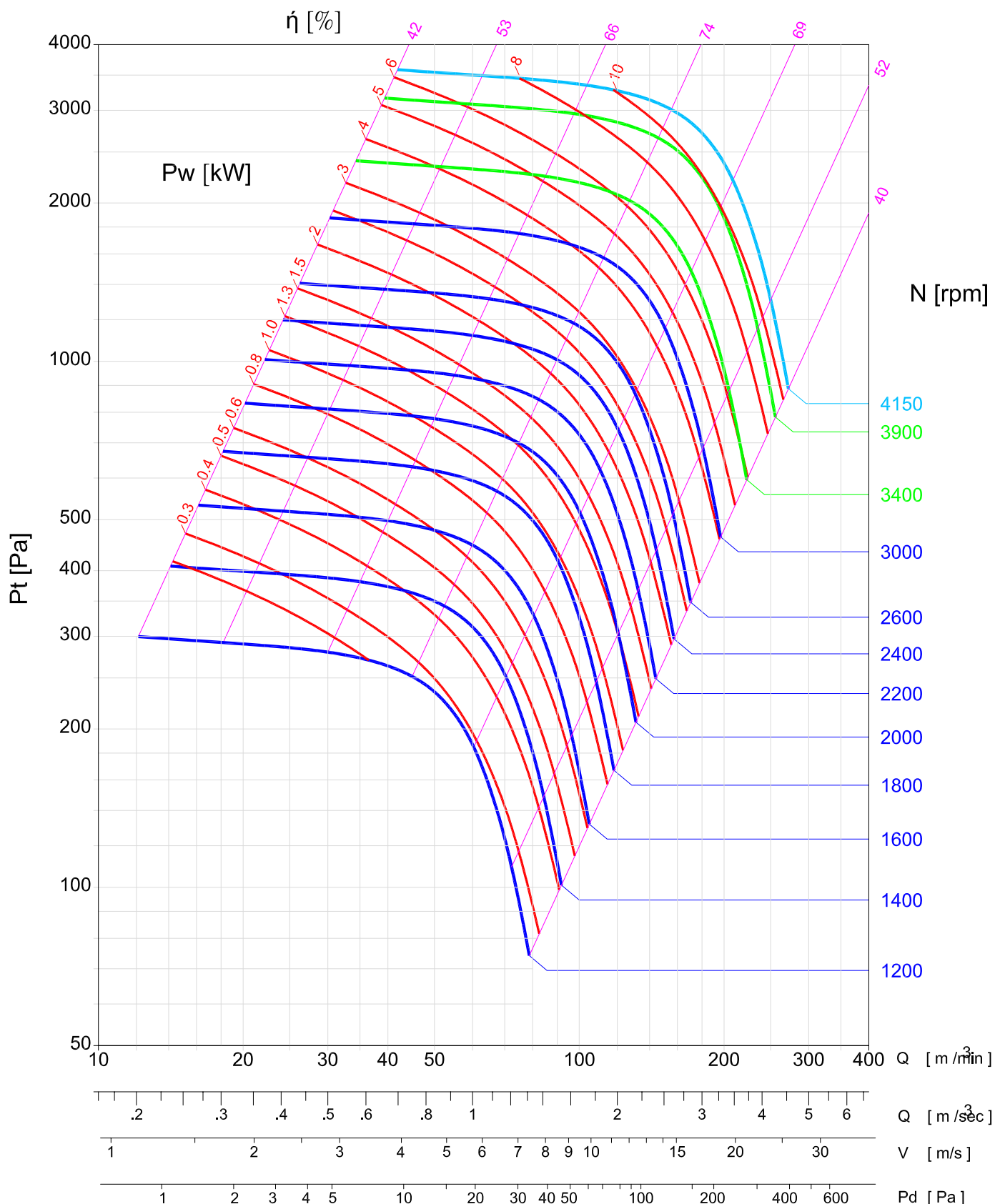

-Performance certified is for installation type B – Free inlet, Ducted outlet. Performance ratings do not include the effects of appurtenances (accessories). Power rating kW does not include transmission losses.



BCZ400



WHEEL : 400 mm
 OUTLET: 560 x 400 mm(WxH,inside)
 : 0.244 m²(inside area)

Op. Limit	CL.I	CL.II	CL.III
Type	L-M	H	V
M. kW	6	12.5	15
M. RPM	2700	3400	3700

FEG80

$r = 1.2 \text{ kg/m}^3$

Type L-M
 Type H
 Type V

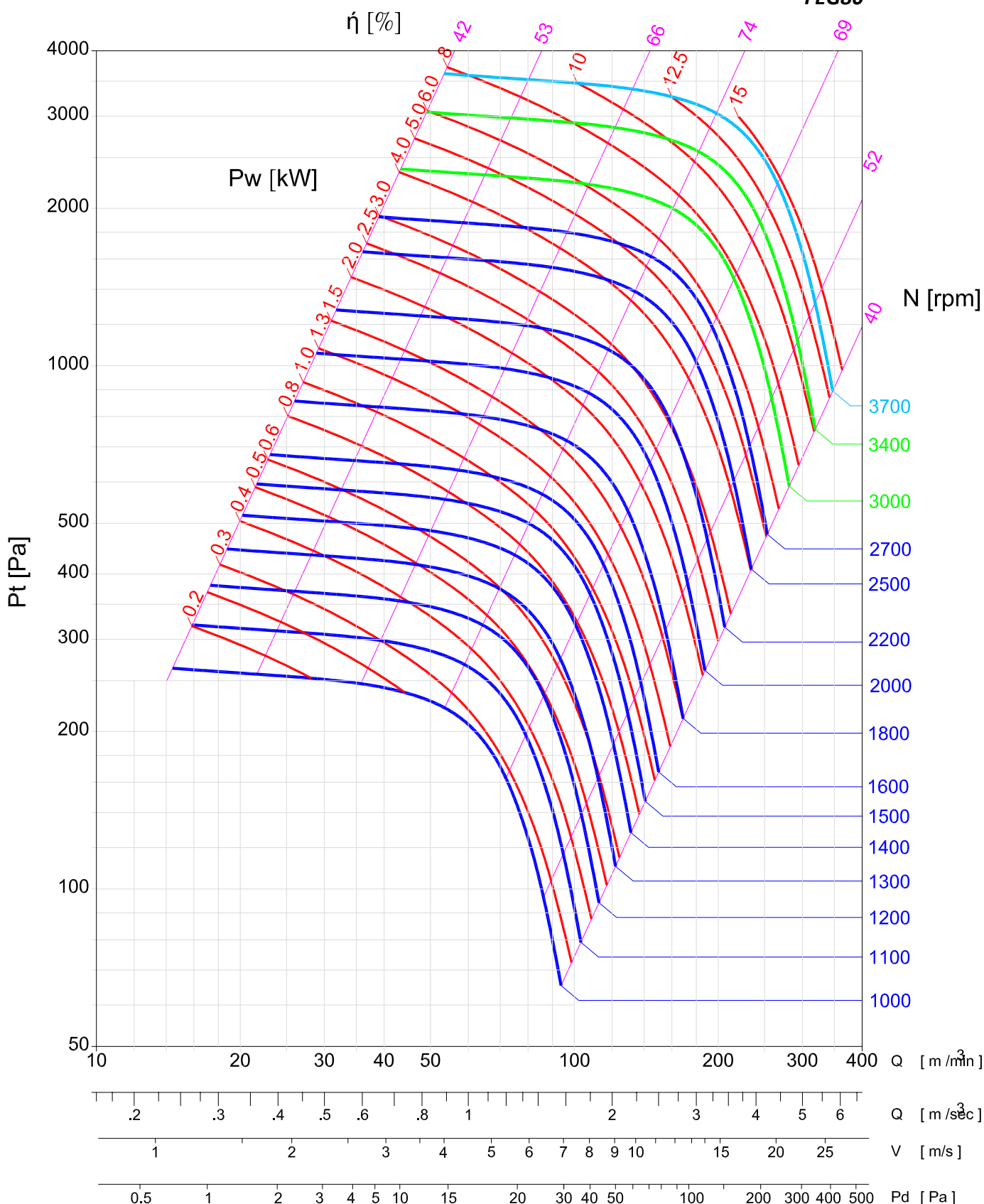

-Performance certified is for installation type B – Free inlet, Ducted outlet. Performance ratings do not include the effects of appurtenances (accessories). Power rating kW does not include transmission losses.



BCZ450

WHEEL : 450 mm OUTLET: 640 x 450 mm(WxH,inside)
: 0.288 m²(inside area)



Op. Limit	CL.I	CL.II	CL.III
Type	L-M	H	V
M. kW	8	15	20
M. RPM	2400	3100	3300

FEG80

$r = 1.2 \text{ kg/m}^3$

Type L-M
 Type H
 Type V

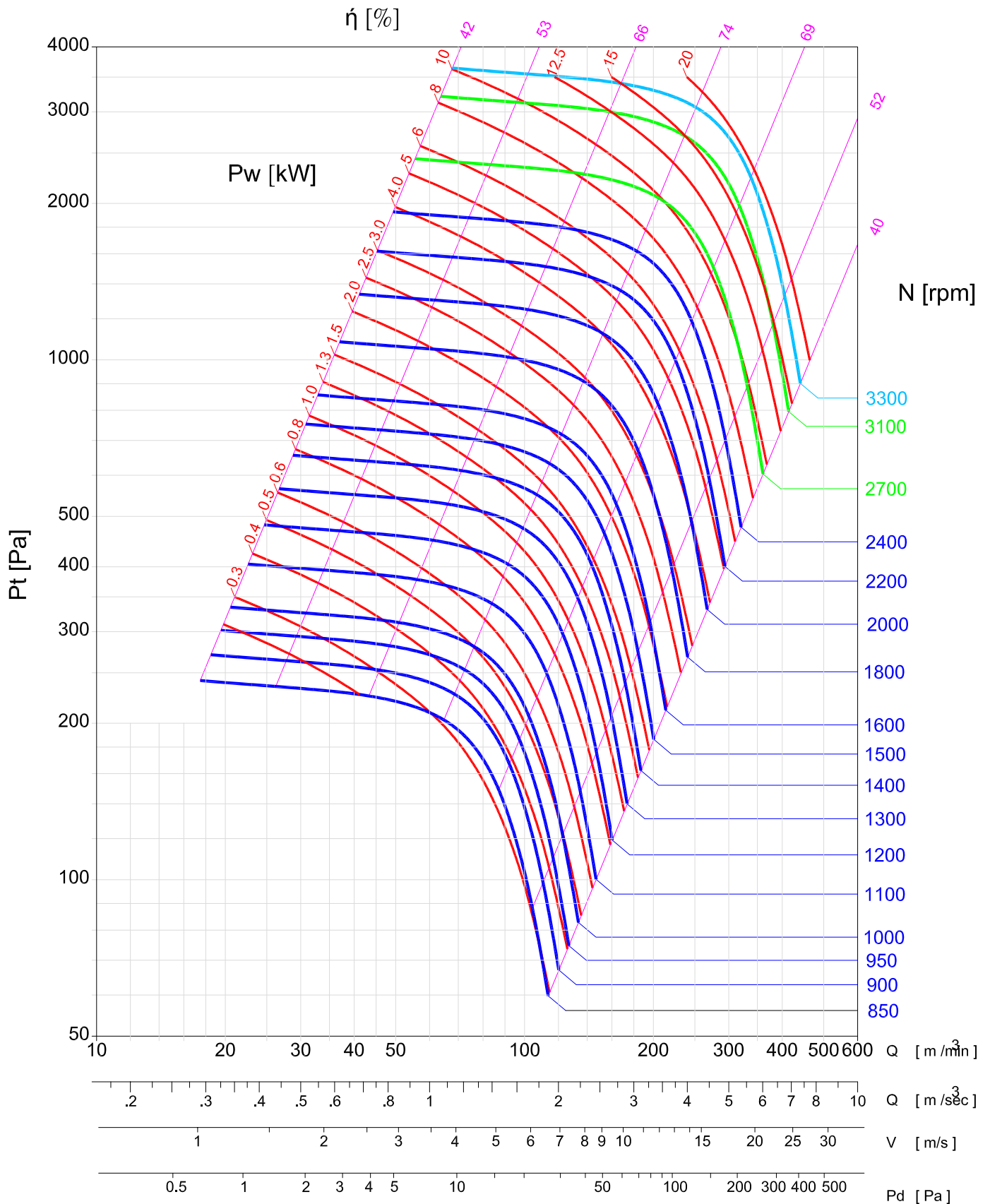

-Performance certified is for installation type B – Free inlet, Ducted outlet. Performance ratings do not include the effects of appurtenances (accessories). Power rating kW does not include transmission losses.



BCZ500

WHEEL : 500 mm OUTLET: 700 x 500 mm(WxH,inside)
: 0.35 m²(inside area)

Op. Limit	CL.I	CL.II	CL.III
Type	M	H	V
M. kW	10	20	25
M. RPM	2150	2800	3000

FEG80

r = 1.2 kg/m³

Type M
 Type H
 Type V

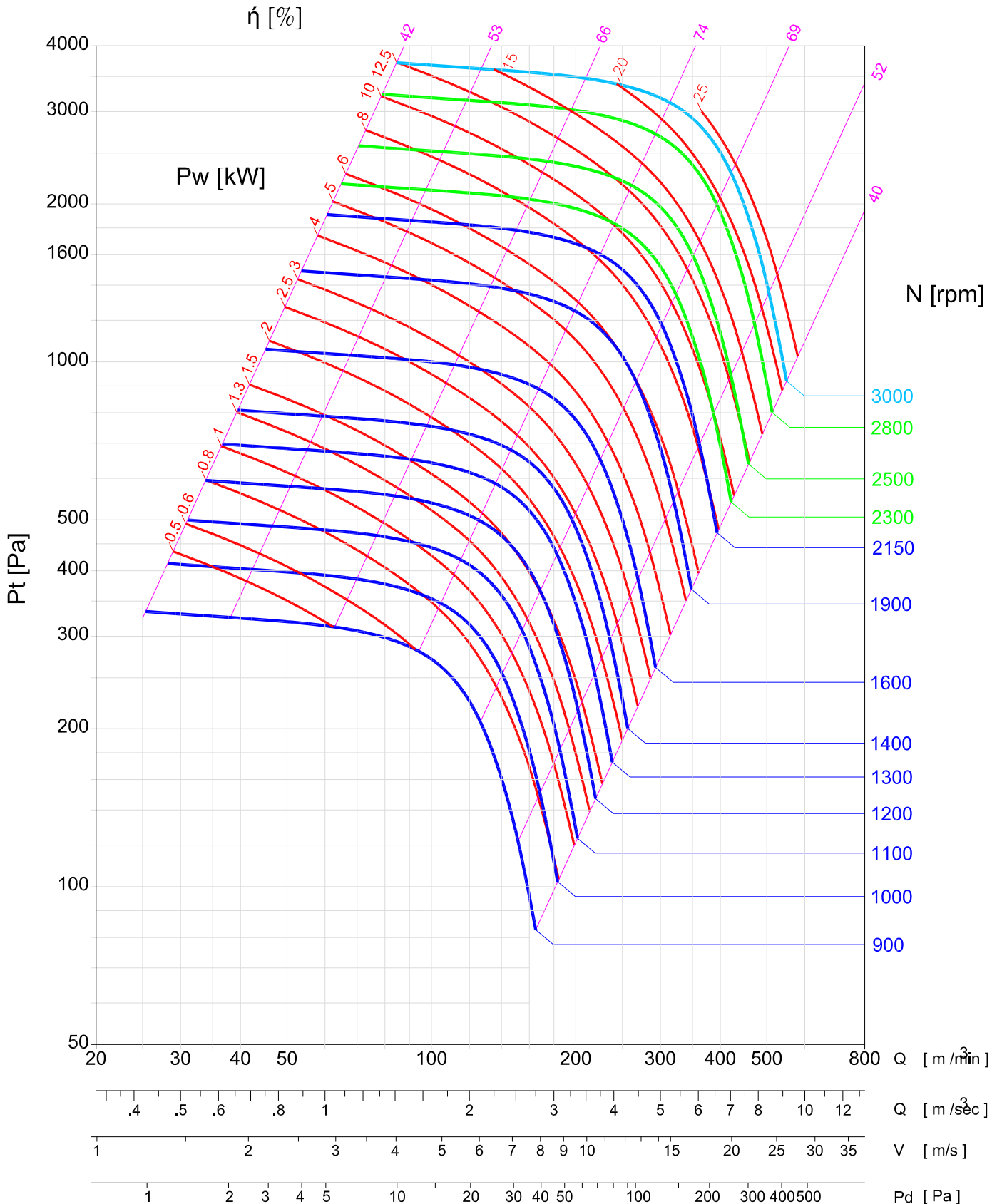

-Performance certified is for installation type B – Free inlet, Ducted outlet. Performance ratings do not include the effects of appurtenances (accessories). Power rating kW does not include transmission losses.



BCZ560



WHEEL : 560 mm OUTLET: 790 x 560 mm(WxH,inside)
 : 0.4424 m²(inside area)

Op. Limit	CL.I	CL.II	CL.III
Type	M	H	V
M. kW	12.5	25	30
M. RPM	1900	2500	2650

Type M
 Type H
 Type V

FEG80

$r = 1.2 \text{ kg/m}^3$

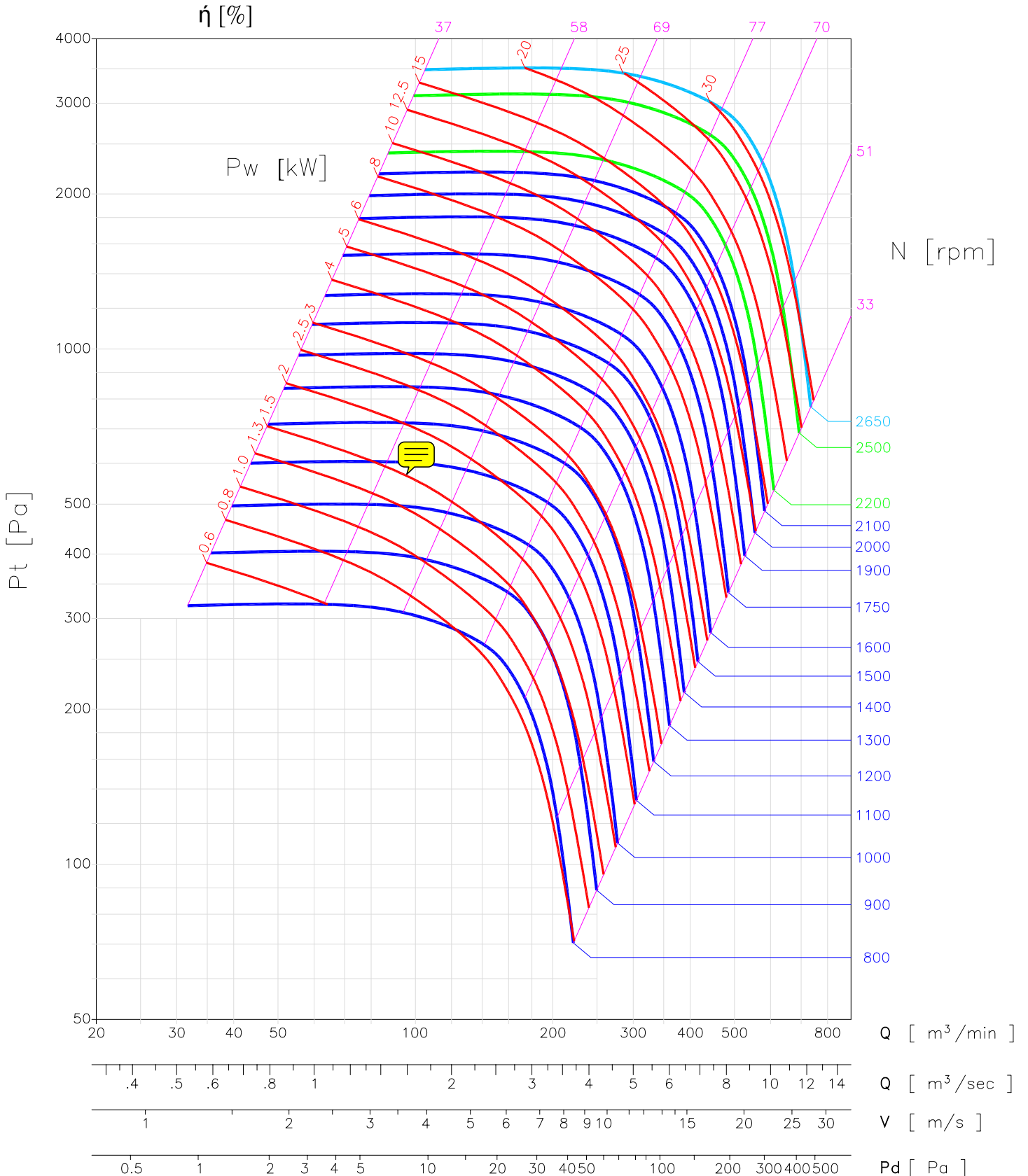

-Performance certified is for installation type B - Free inlet, Ducted outlet. Performance ratings do not include the effects of appurtenances (accessories). Power rating kW does not include transmission losses.



BCZ630

WHEEL : 630 mm OUTLET: 890 x 630 mm(WxH,inside)
: 0.5607 m²(inside area)



Op. Limit	CL.I	CL.II	CL.III
Type	M	H	V
M. kW	12.5	30	50
M. RPM	1600	2100	2400

FEG80

$r = 1.2 \text{ kg/m}^3$

Type M
 Type H
 Type V

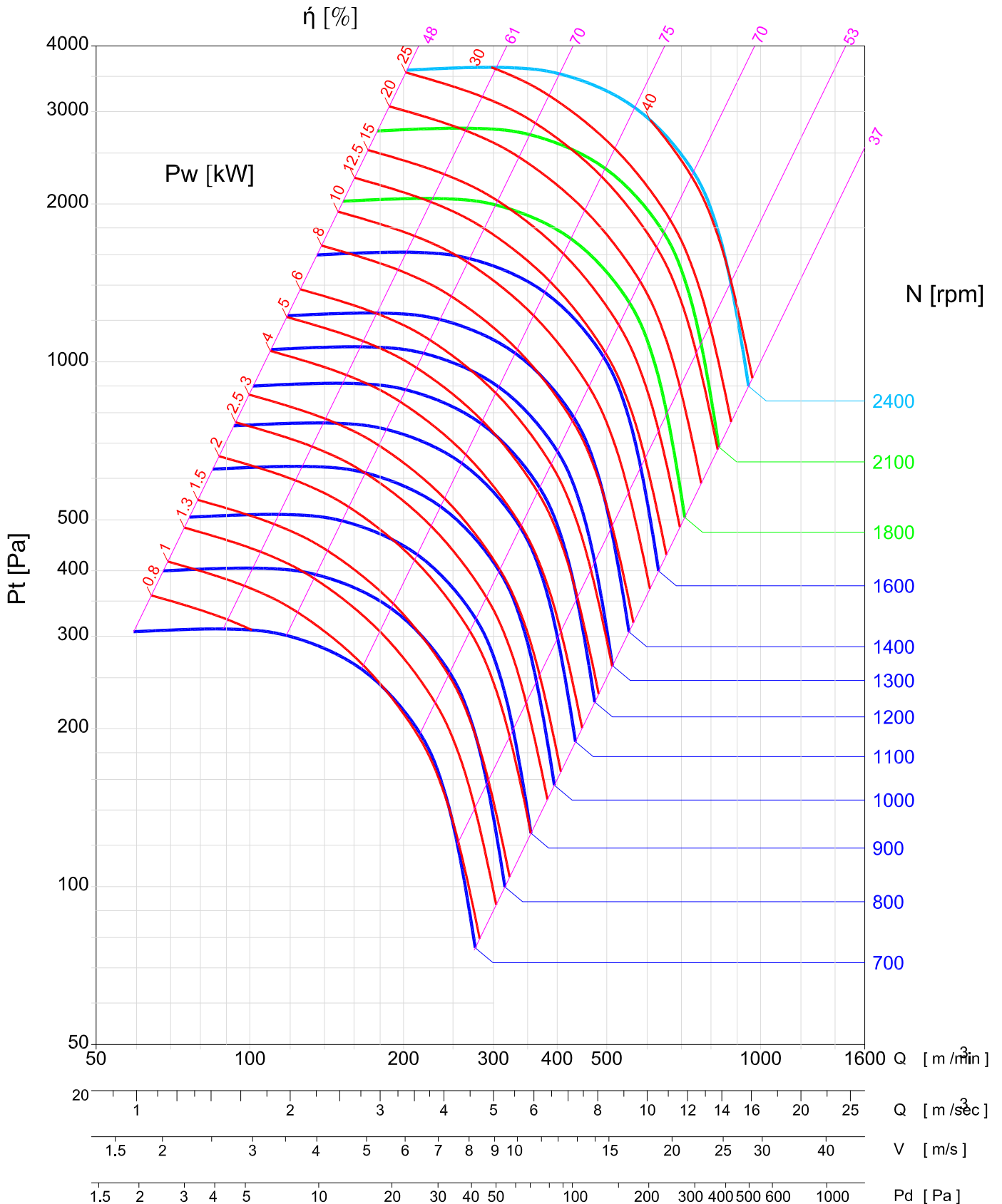

-Performance certified is for installation type B – Free inlet, Ducted outlet. Performance ratings do not include the effects of appurtenances (accessories). Power rating kW does not include transmission losses.



BCZ710

WHEEL : 710 mm OUTLET: 1000 x 710 mm(WxH,inside)
 : 0.71 m²(inside area)

Op. Limit	CL.I	CL.II	CL.III
Type	H	V	X
M. kW	20	40	50
M. RPM	1450	1850	2100

FEG80

$r = 1.2 \text{ kg/m}^3$

Type H
 Type V
 Type X

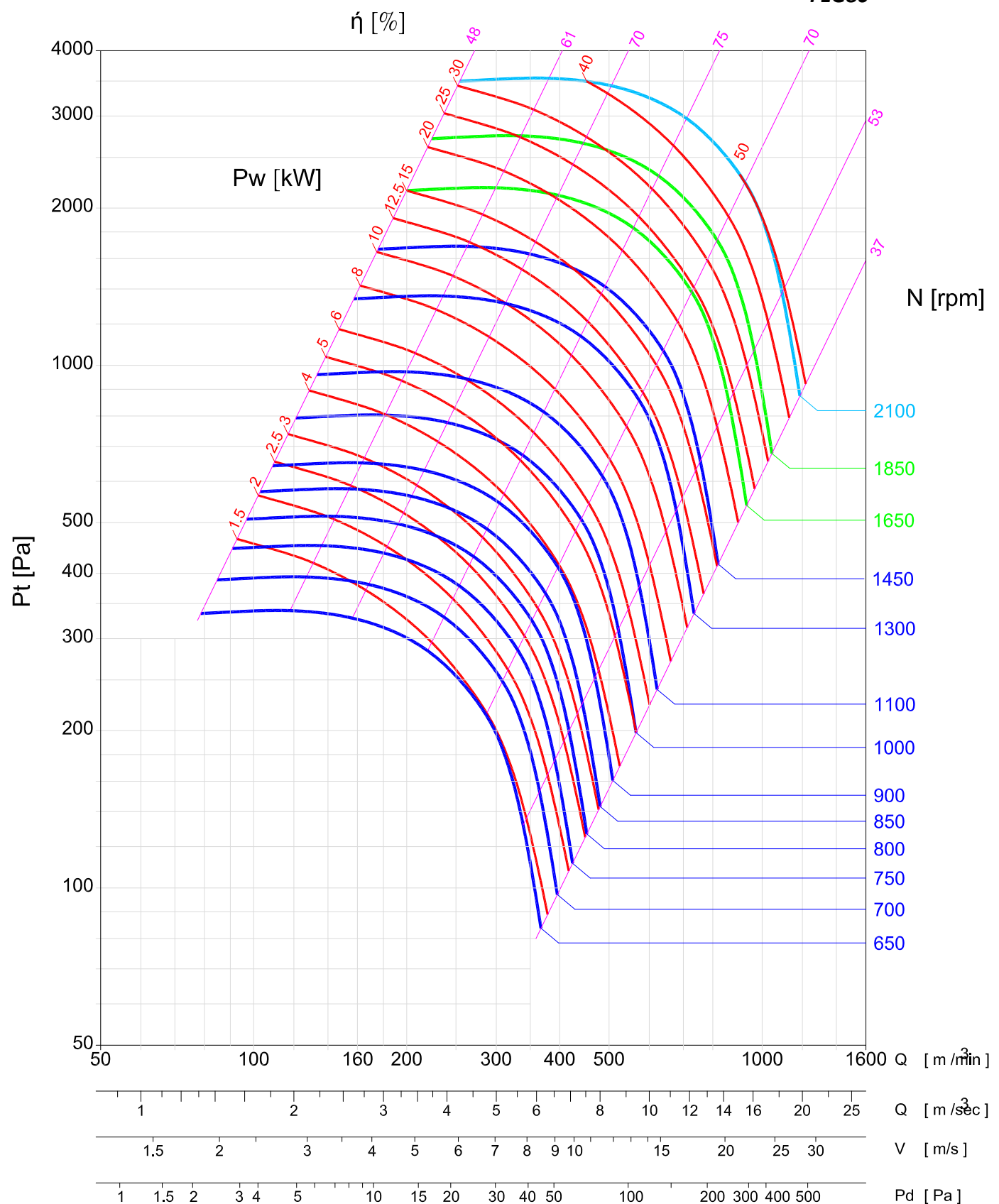

-Performance certified is for installation type B – Free inlet, Ducted outlet. Performance ratings do not include the effects of appurtenances (accessories). Power rating kW does not include transmission losses.



BCZ800

WHEEL : 800 mm OUTLET: 1130 x 800 mm(WxH,inside)
: 0.904 m²(inside area)



Op. Limit	CL.I	CL.II	CL.III
Type	H	V	X
M. kW	25	50	80
M. RPM	1300	1650	1900

FEG80

$r = 1.2 \text{ kg/m}^3$

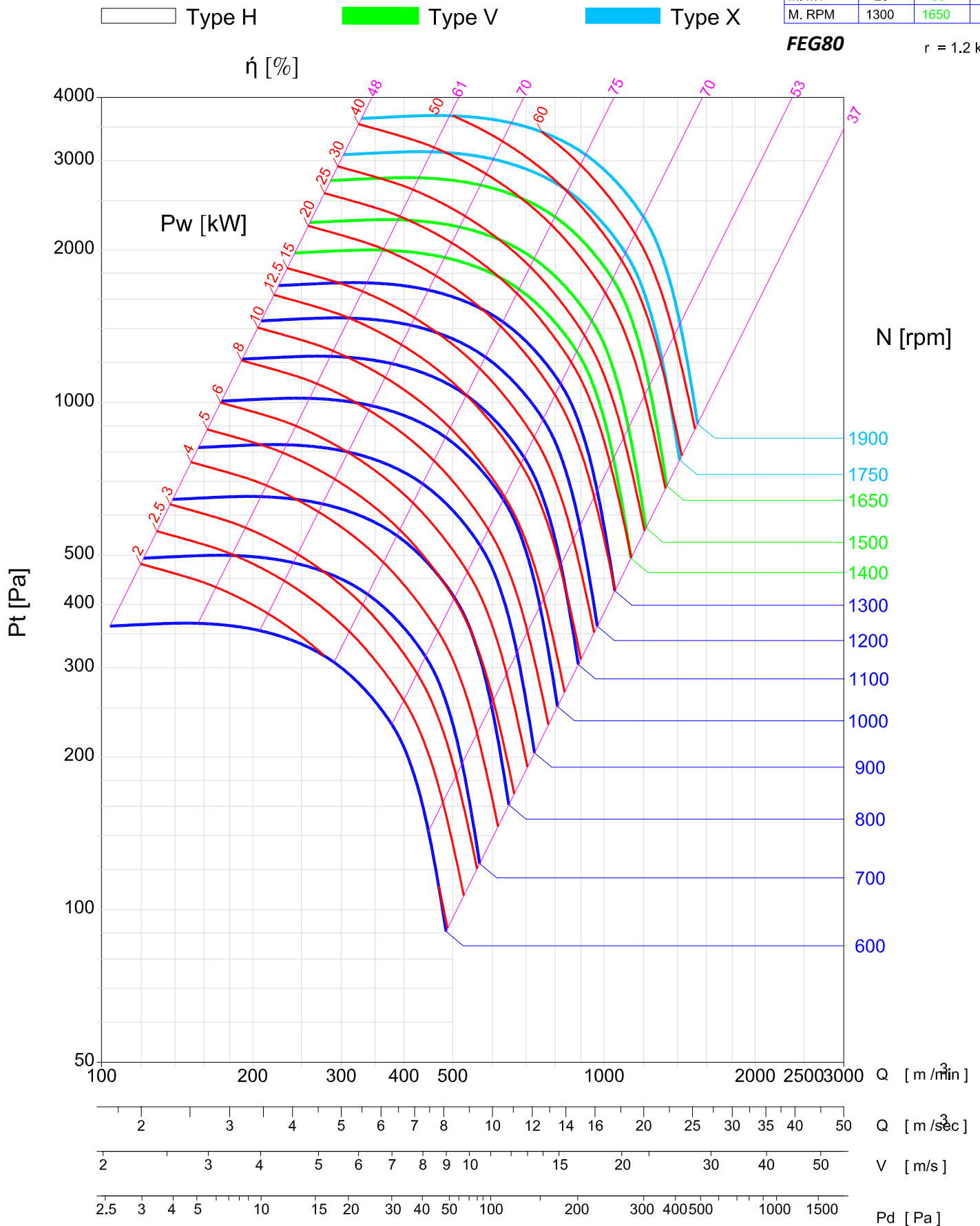

-Performance certified is for installation type B – Free inlet, Ducted outlet. Performance ratings do not include the effects of appurtenances (accessories). Power rating kW does not include transmission losses.



BCZ900

WHEEL : 900 mm OUTLET: 1270 x 900 mm(WxH,inside)
 : 1.143 m²(inside area)



Op. Limit	CL.I	CL.II	CL.III
Type	H	V	X
M. kW	30	60	80
M. RPM	1150	1500	1650

Type H
 Type V
 Type X

FEG80

$r = 1.2 \text{ kg/m}^3$

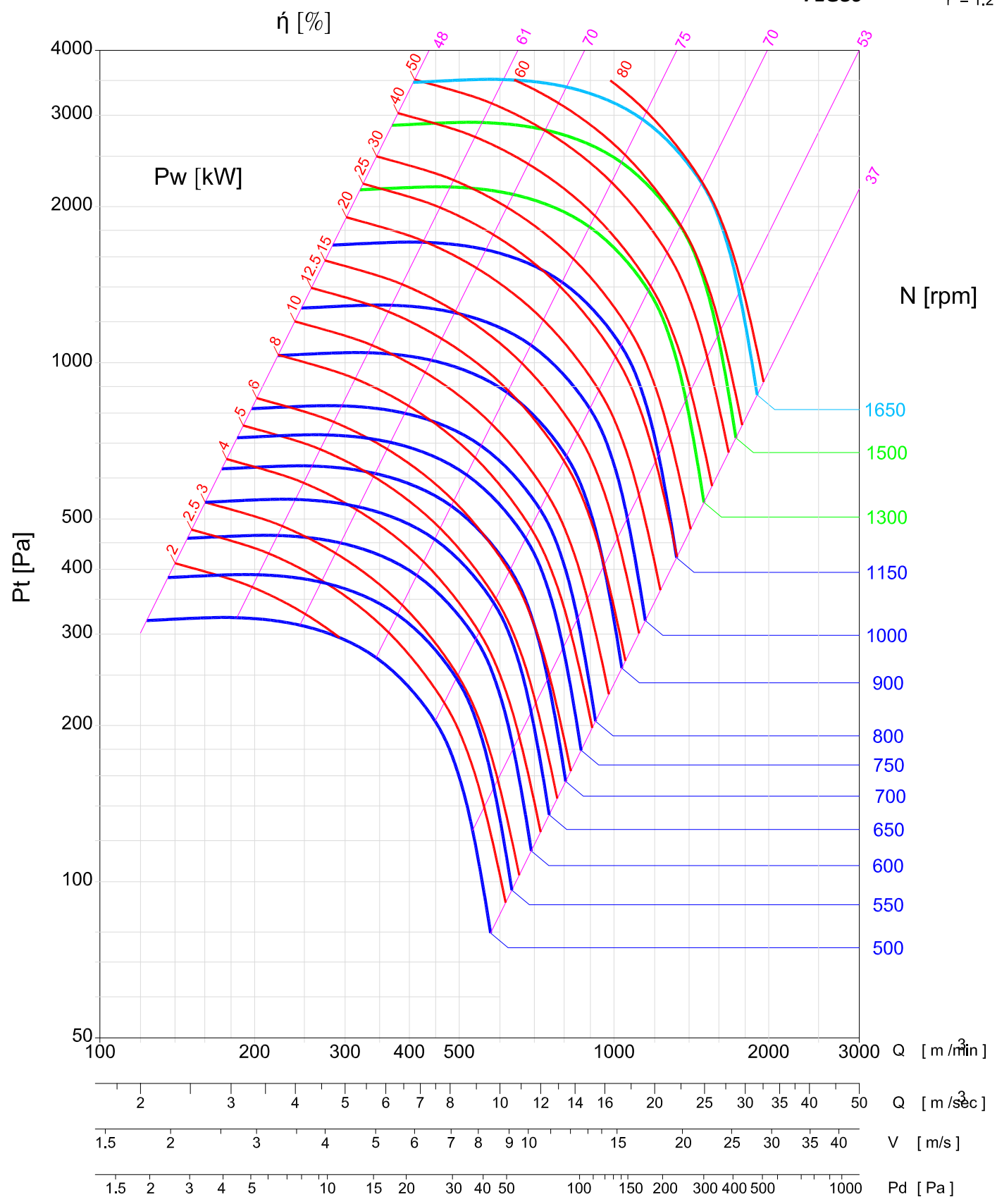

-Performance certified is for installation type B – Free inlet, Ducted outlet. Performance ratings do not include the effects of appurtenances (accessories). Power rating kW does not include transmission losses.



BCZ1000

WHEEL : 1000 mm OUTLET: 1400 x 1000 mm(WxH,inside)
: 1.4 m²(inside area)

Op. Limit	CL.I	CL.II	CL.III
Type	H	V	X
M. kW	30	80	100
M. RPM	1000	1300	1500

FEG80 r = 1.2 kg/m³

Type H
 Type V
 Type X

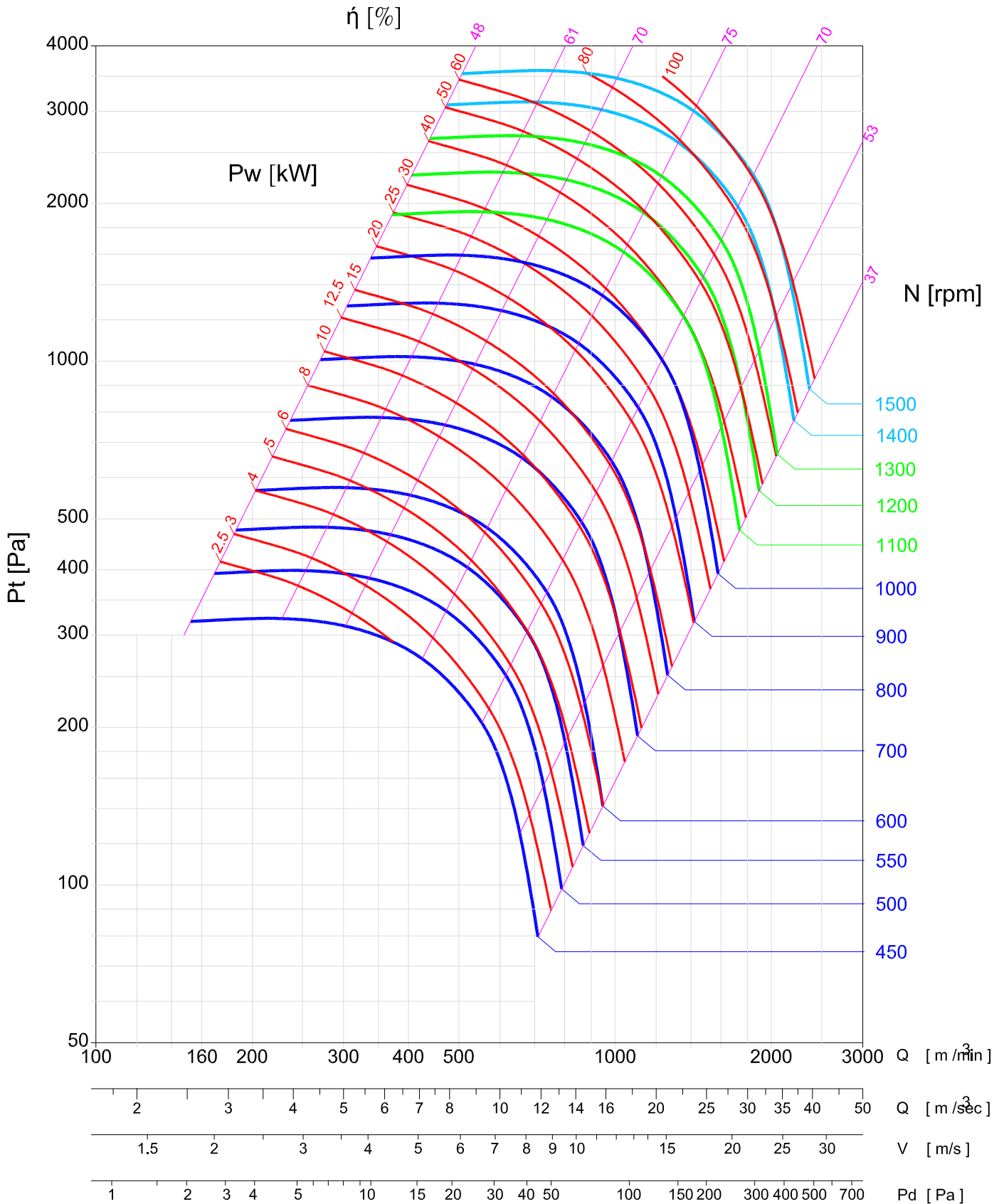

-Performance certified is for installation type B – Free inlet, Ducted outlet. Performance ratings do not include the effects of appurtenances (accessories). Power rating kW does not include transmission losses.



BCZ1120

WHEEL : 1120 mm
 OUTLET: 1580 x 1120 mm(WxH,inside)
 : 1.7696 m²(inside area)

Op. Limit	CL.I	CL.II	CL.III
Type	H	V	X
M. kW	50	100	150
M. RPM	950	1200	1350

FEG80

$r = 1.2 \text{ kg/m}^3$

Type H
 Type V
 Type X

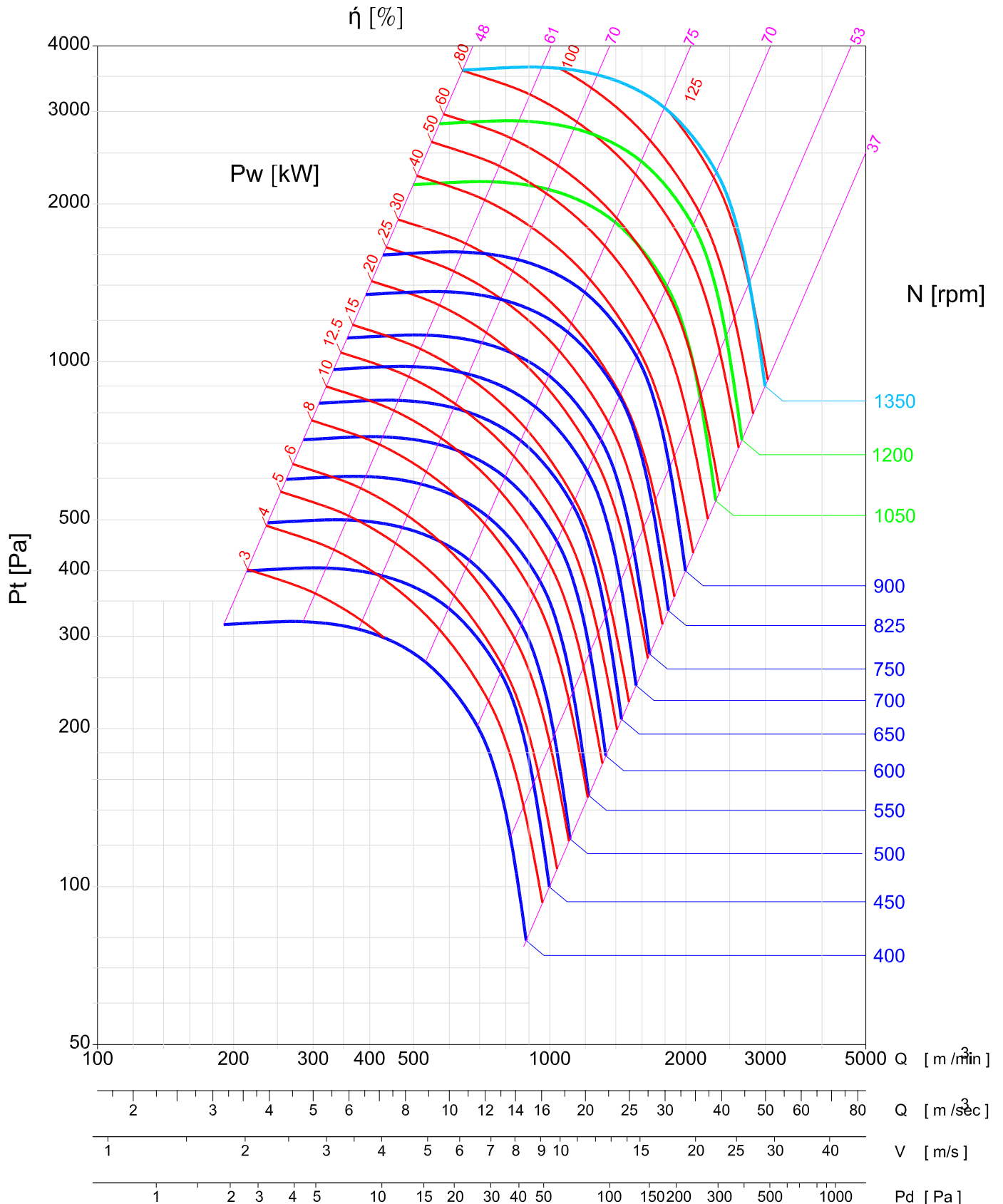

-Performance certified is for installation type B – Free inlet, Ducted outlet. Performance ratings do not include the effects of appurtenances (accessories). Power rating kW does not include transmission losses.



BCZ1250

WHEEL : 1250 mm
 OUTLET: 1770 x 1250 mm(WxH,inside)
 : 2.2125 m²(inside area)



Op. Limit	CL.I	CL.II	CL.III
Type	H	V	X
M. kW	60	125	200
M. RPM	825	1050	1200

FEG80

$\rho = 1.2 \text{ kg/m}^3$

Type H
 Type V
 Type X

η [%]

Pw [kW]

Pt [Pa]

N [rpm]

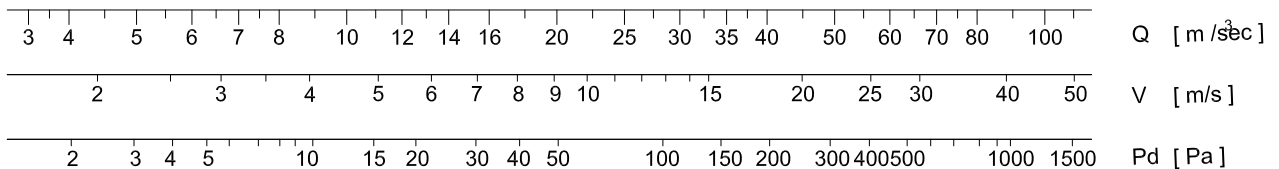
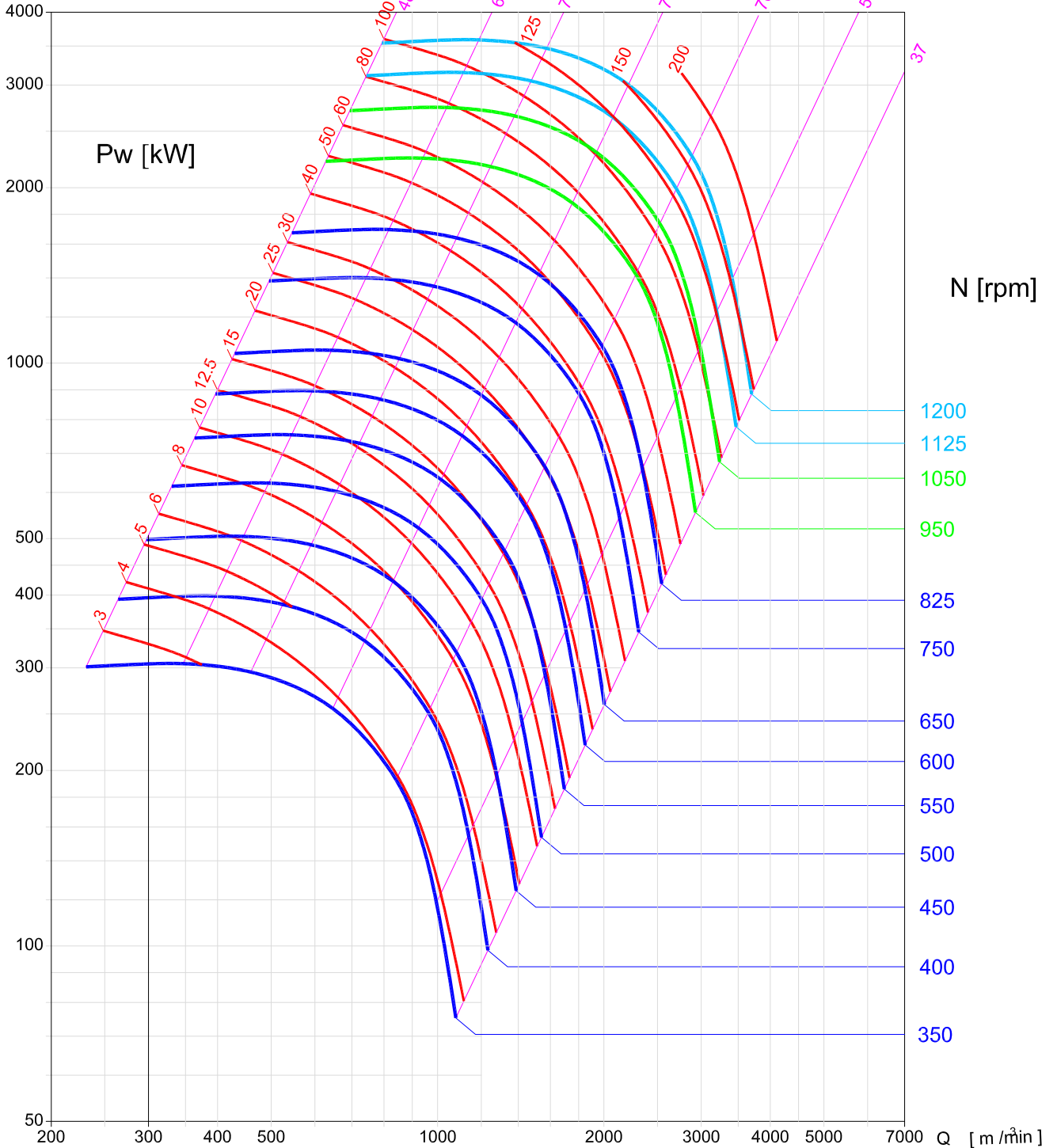

-Performance certified is for installation type B – Free inlet, Ducted outlet. Performance ratings do not include the effects of appurtenances (accessories). Power rating kW does not include transmission losses.



BCZ1400



WHEEL : 1400 mm
 OUTLET: 1980 x 1400 mm(WxH,inside)
 : 2.772 m²(inside area)

Op. Limit	CL.I	CL.II	CL.III
Type	H	V	X
M. kW	60	150	200
M. RPM	720	950	1070

FEG80

$r = 1.2 \text{ kg/m}^3$

Type H
 Type V
 Type X

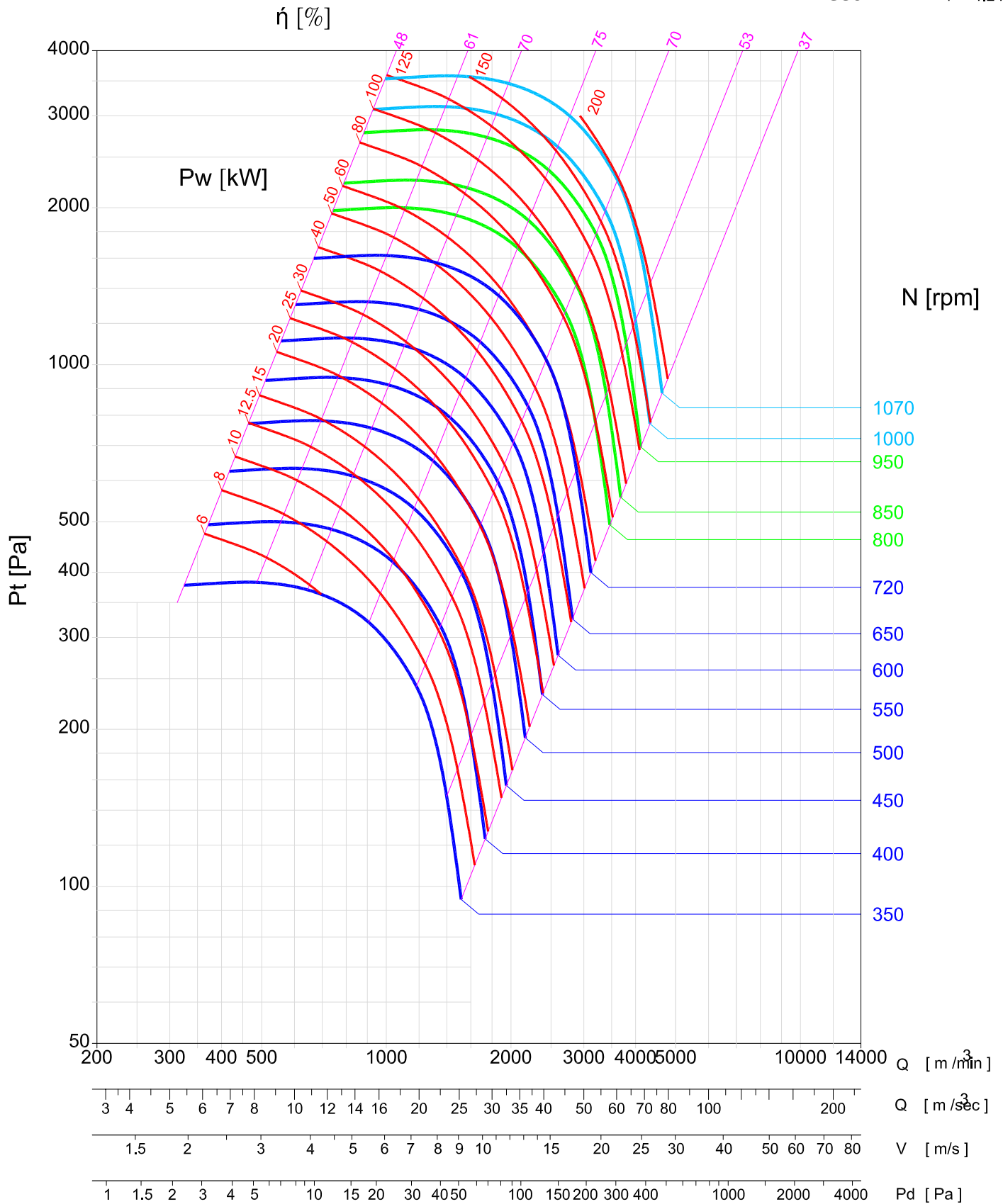

-Performance certified is for installation type B – Free inlet, Ducted outlet. Performance ratings do not include the effects of appurtenances (accessories). Power rating kW does not include transmission losses.



BCZ1600

WHEEL : 1600 mm OUTLET: 2260 x 1600 mm(WxH,inside)
:3.616 m²(inside area)

Op. Limit	CL.I	CL.II	CL.III
Type	H	V	X
M. kW	80	200	300
M. RPM	625	825	935

FEG80

$r = 1.2 \text{ kg/m}^3$

Type H
 Type V
 Type X

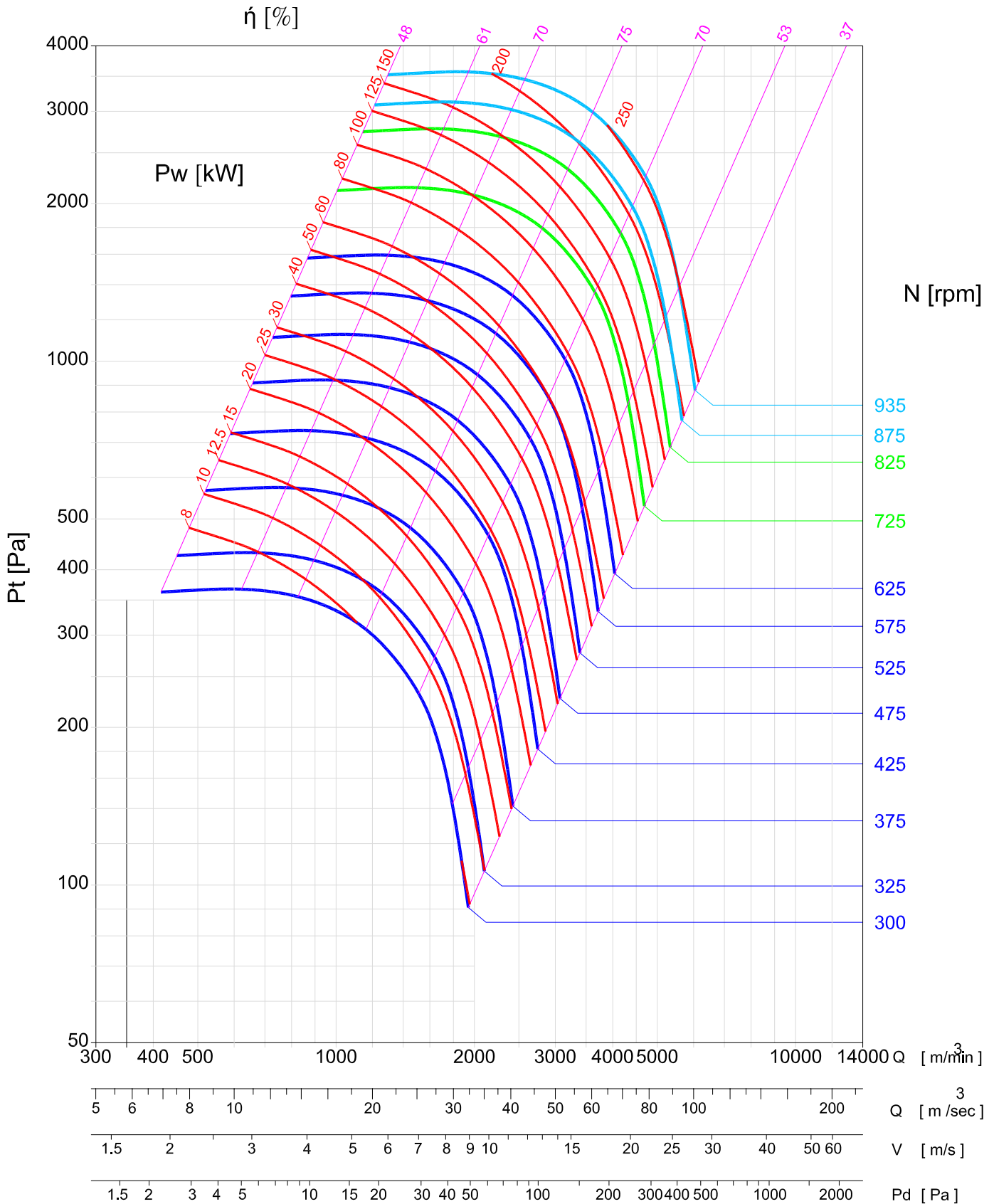

-Performance certified is for installation type B – Free inlet, Ducted outlet. Performance ratings do not include the effects of appurtenances (accessories). Power rating kW does not include transmission losses.



BCZ1800

WHEEL : 1800 mm OUTLET: 2550 x 1800 mm(WxH,inside)
: 4.59 m²(inside area)

Op. Limit	CL.I	CL.II	CL.III
Type	H	V	X
M. kW	125	250	300
M. RPM	575	725	400

FEG80

$r = 1.2 \text{ kg/m}^3$

Type H
 Type V
 Type X

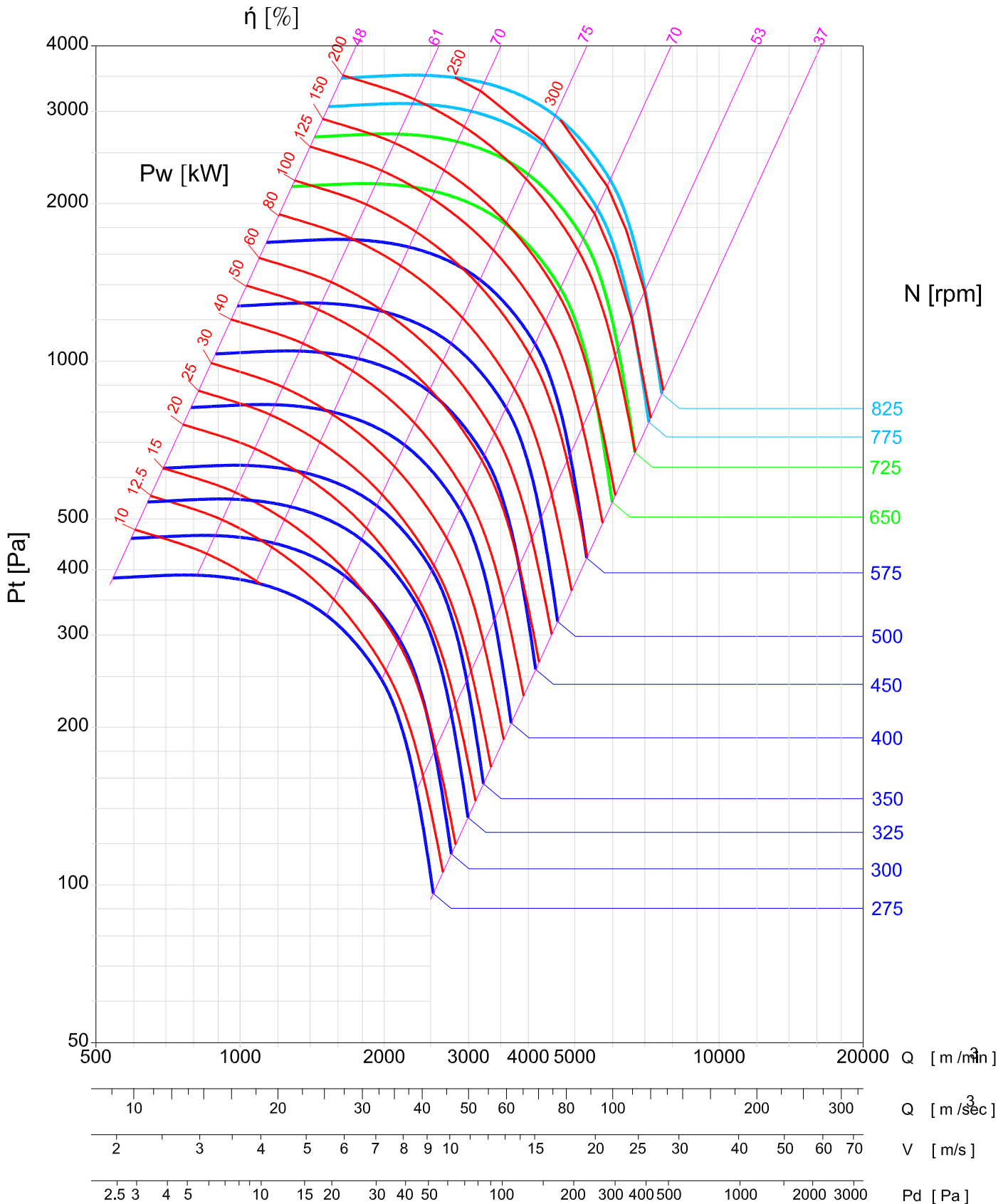

-Performance certified is for installation type B – Free inlet, Ducted outlet. Performance ratings do not include the effects of appurtenances (accessories). Power rating kW does not include transmission losses.



BCZ2000



WHEEL : 2000 mm OUTLET: 2850 x 2000 mm(WxH,inside)
: 5.7 m²(inside area)

Op. Limit	CL.I	CL.II	CL.III
Type	H	V	X
M. kW	125	300	400
M. RPM	500	650	750

Type H
 Type V
 Type X

FEG80

$r = 1.2 \text{ kg/m}^3$

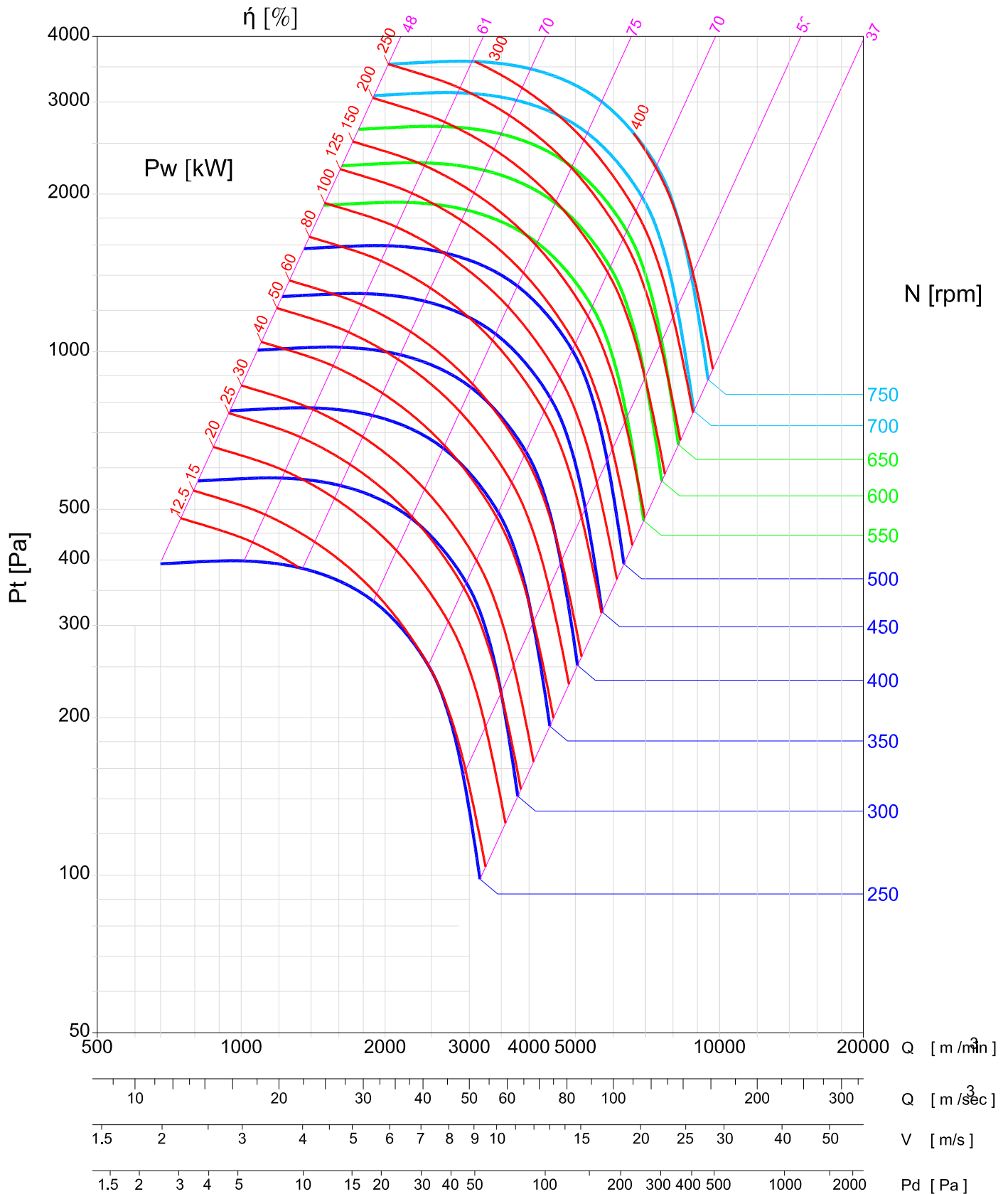

-Performance certified is for installation type B – Free inlet, Ducted outlet. Performance ratings do not include the effects of appurtenances (accessories). Power rating kW does not include transmission losses.



Sound Performance Data



BCZ Series

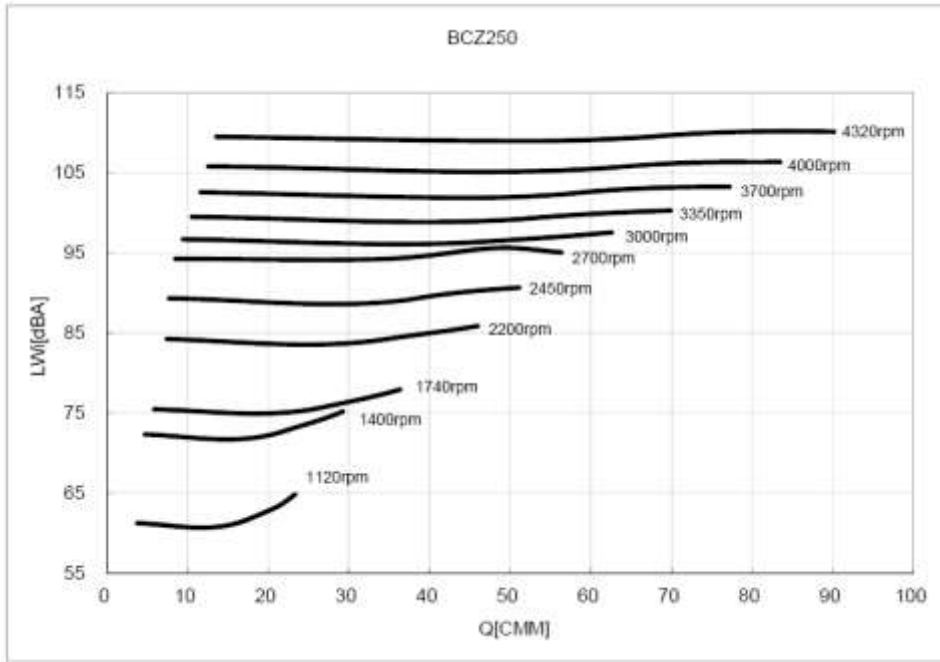

Sound Power [dB Ref 10-12 watts] %POF=(CMM*3531.5 / RPM x 0.74)

Inlet Sound Power, Lwi [Octave Band]

		1	2	3	4	5	6	7	8	LwiA
RPM	%POF	63	125	250	500	1K	2K	4K	8K	[dBA]
1120	100	73	68	68	63	58	53	48	41	64.9
	87	74	67	66	60	57	51	46	39	63.0
	58	74	67	64	58	53	48	44	39	60.8
	16	75	68	65	58	53	48	44	39	61.3
1740	100	86	84	81	76	70	66	61	55	78.0
	87	87	84	79	75	69	64	59	53	76.8
	58	87	84	77	73	66	61	56	52	75.0
	16	88	85	78	73	66	60	56	52	75.5
2450	100	109	98	90	89	82	76	71	66	90.7
	85	110	99	90	87	79	74	69	64	90.1
	60	108	99	89	85	76	71	66	62	88.7
	15	108	100	90	86	76	71	65	62	89.4
3000	100	117	104	97	96	88	82	77	72	97.6
	85	118	105	97	93	85	80	74	70	96.9
	60	117	105	97	92	83	77	72	68	96.1
	15	117	106	98	93	83	77	71	67	96.7
3700	100	121	111	106	100	94	87	83	78	103.3
	85	122	111	106	99	93	86	81	76	103.1
	60	121	109	106	97	91	83	78	73	101.9
	15	121	110	107	98	91	83	77	73	102.6
4320	100	124	122	112	105	100	93	87	82	110.1
	85	125	122	113	104	98	90	86	80	110.1
	60	124	120	113	103	97	88	82	78	109.0
	15	124	120	114	104	97	88	82	77	109.5

The sound power level ratings shown are in decibels. Referred to 10-12 watts calculated per AMCA Standard 301. Values shown are for inlet Lwi, LwiA sound power level for installation Type B: free inlet, ducted outlet. The A-weighted sound ratings shown have been calculated per AMCA Standard 301.

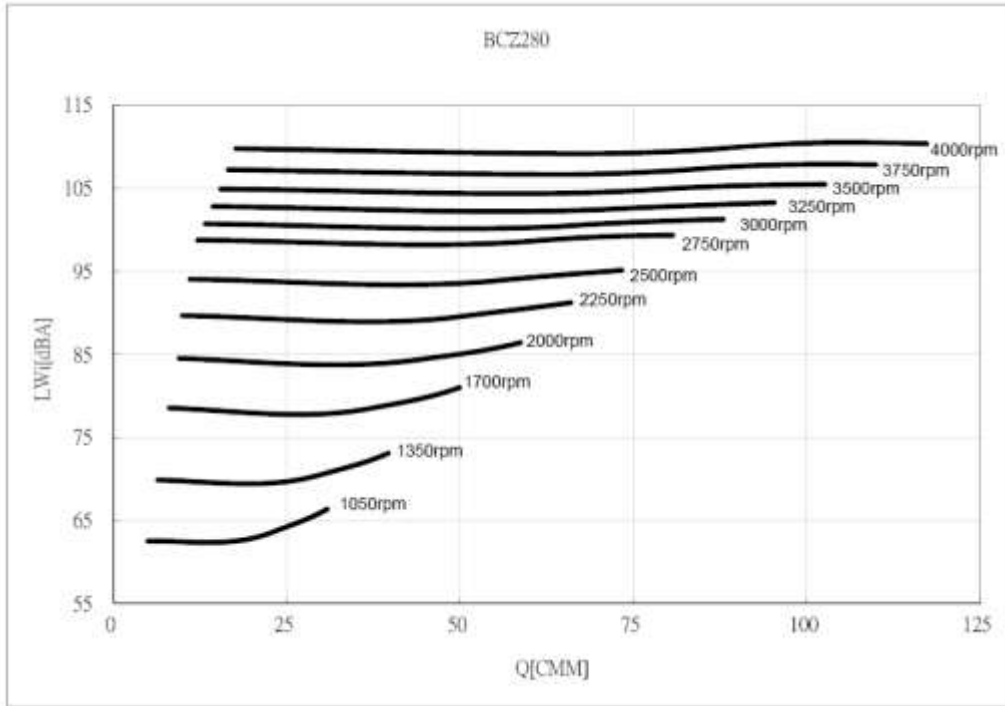

Sound Power [dB Ref 10-12 watts] %POF=(CMM*3531.5 / RPM x 1.03)

Inlet Sound Power, Lwi [Octave Band]

RPM	%POF	Octave Band								LwiA [dBA]
		63	125	250	500	1K	2K	4K	8K	
1050	100	75	71	69	64	60	55	49	42	66.4
	87	76	70	68	62	58	53	48	41	64.8
	58	76	69	66	59	55	50	46	41	62.5
	16	77	70	66	59	54	49	46	41	62.5
1700	100	90	87	84	79	73	69	64	57	81.0
	87	91	87	82	77	72	67	62	56	79.5
	58	91	87	80	75	69	64	59	55	77.8
	16	92	88	81	76	69	63	59	55	78.6
2250	100	108	98	92	90	82	77	72	67	91.2
	85	108	99	91	88	80	75	70	65	90.2
	60	107	99	90	86	77	72	67	63	88.9
	15	107	100	91	87	77	71	66	63	89.7
2750	100	120	107	97	97	89	83	77	73	99.3
	85	121	108	97	95	85	81	75	71	99.1
	60	120	108	97	93	83	78	73	69	98.2
	15	120	109	98	94	83	78	71	68	98.8
3250	100	123	110	104	101	93	87	82	78	103.3
	85	124	111	104	98	91	86	80	76	102.8
	60	123	111	104	97	90	83	77	73	102.2
	15	123	112	105	98	90	83	77	73	102.8
3750	100	126	117	110	104	98	91	87	82	107.8
	85	127	116	111	103	97	90	85	80	107.8
	60	126	114	111	101	95	87	82	77	106.7
	15	126	114	112	102	95	87	81	77	107.2

The sound power level ratings shown are in decibels. Referred to 10-12 watts calculated per AMCA Standard 301. Values shown are for inlet Lwi, LwiA sound power level for installation Type B: free inlet, ducted outlet. The A-weighted sound ratings shown have been calculated per AMCA Standard 301.

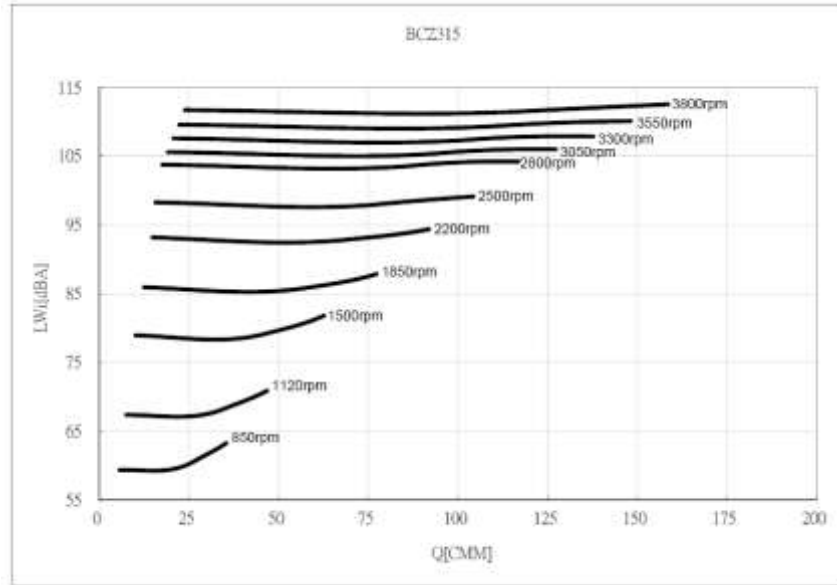

Sound Power [dB Ref 10-12 watts] %POF=(CMM*3531.5 / RPM x1.47)

Inlet Sound Power, Lwi [Octave Band]

RPM	%POF	Octave Band								LwiA [dBA]
		63	125	250	500	1K	2K	4K	8K	
850	100	71	69	65	61	57	53	46	39	63.3
	87	71	67	64	60	55	51	45	38	61.9
	58	71	66	62	57	52	48	43	38	59.5
	16	72	66	62	57	51	48	43	38	59.4
1500	100	93	86	86	79	74	69	64	57	81.8
	87	94	86	84	77	73	67	62	56	80.3
	58	94	86	82	75	69	64	59	55	78.4
	16	95	87	83	75	69	63	59	55	79.0
2200	100	111	102	95	93	85	80	75	70	94.4
	87	111	103	94	91	83	78	73	68	93.4
	58	110	103	94	89	80	75	70	66	92.4
	16	110	104	95	90	80	74	69	66	93.2
2800	100	125	112	102	102	93	87	82	78	104.2
	85	126	113	102	100	90	86	79	75	104.1
	60	125	113	102	98	88	82	77	73	103.2
	15	125	114	103	99	88	82	76	73	103.7
3300	100	128	115	109	105	97	91	86	82	107.9
	85	129	116	109	103	96	90	84	80	107.8
	60	128	116	109	101	94	87	81	77	107.0
	15	128	117	110	102	94	87	81	77	107.6
3800	100	130	122	115	109	102	95	91	86	112.5
	85	131	121	115	107	101	94	89	84	112.0
	60	130	120	115	106	99	91	86	81	111.2
	15	130	120	116	107	99	91	85	81	111.7

The sound power level ratings shown are in decibels. Referred to 10-12 watts calculated per AMCA Standard 301. Values shown are for inlet Lwi, LwiA sound power level for installation Type B: free inlet, ducted outlet. The A-weighted sound ratings shown have been calculated per AMCA Standard 301.

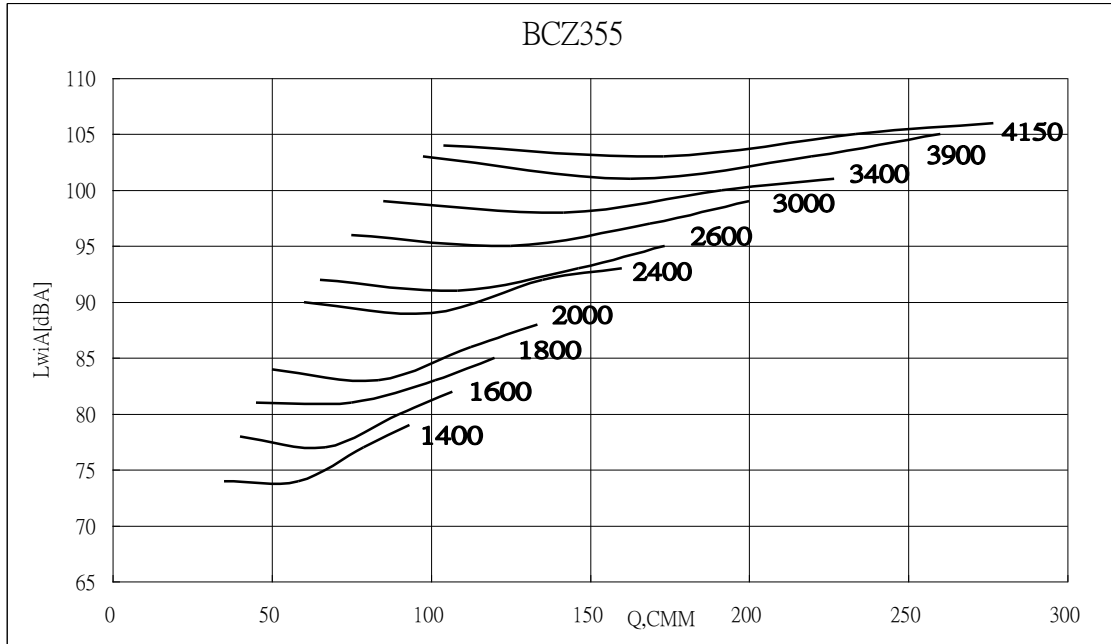

Sound Power [dB Ref 10-12 watts] %POF=(CMM*3531.5 / RPM x 2.5)

Inlet Sound Power, Lwi [Octave Band]

RPM	%POF	LwiA [dBA]								
		63	125	250	500	1K	2K	4K	8K	
1600	94	83	80	84	80	75	73	72	60	82
	79	84	80	82	78	73	72	67	56	80
	59	85	80	80	75	69	69	64	57	77
	35	87	82	82	75	69	67	62	58	78
2000	94	87	87	88	86	82	79	78	70	88
	79	89	86	87	84	80	77	74	64	86
	59	89	87	85	81	76	74	71	64	83
	35	92	88	88	82	76	73	69	64	84
2400	94	95	91	90	92	88	83	82	78	93
	79	97	91	89	91	86	81	79	71	92
	59	95	92	88	88	82	78	76	69	89
	35	98	92	91	89	82	77	74	69	90
3000	94	100	98	93	98	93	88	87	85	99
	79	99	101	93	96	92	86	85	80	97
	59	98	100	92	94	88	83	82	76	95
	35	99	102	95	96	88	82	81	76	96
3400	94	103	98	97	100	96	92	90	89	101
	79	102	100	97	99	95	90	88	84	100
	59	101	100	97	97	91	86	85	81	98
	35	102	103	98	99	92	86	84	79	99
4150	94	108	102	102	103	102	98	95	94	106
	79	107	103	102	102	100	96	93	90	105
	59	105	104	103	101	97	93	90	87	103
	35	107	107	104	103	98	92	89	85	104

The sound power level ratings shown are in decibels. Referred to 10-12 watts calculated per AMCA Standard 301. Values shown are for inlet Lwi, LwiA sound power level for installation Type B: free inlet, ducted outlet. The A-weighted sound ratings shown have been calculated per AMCA Standard 301.

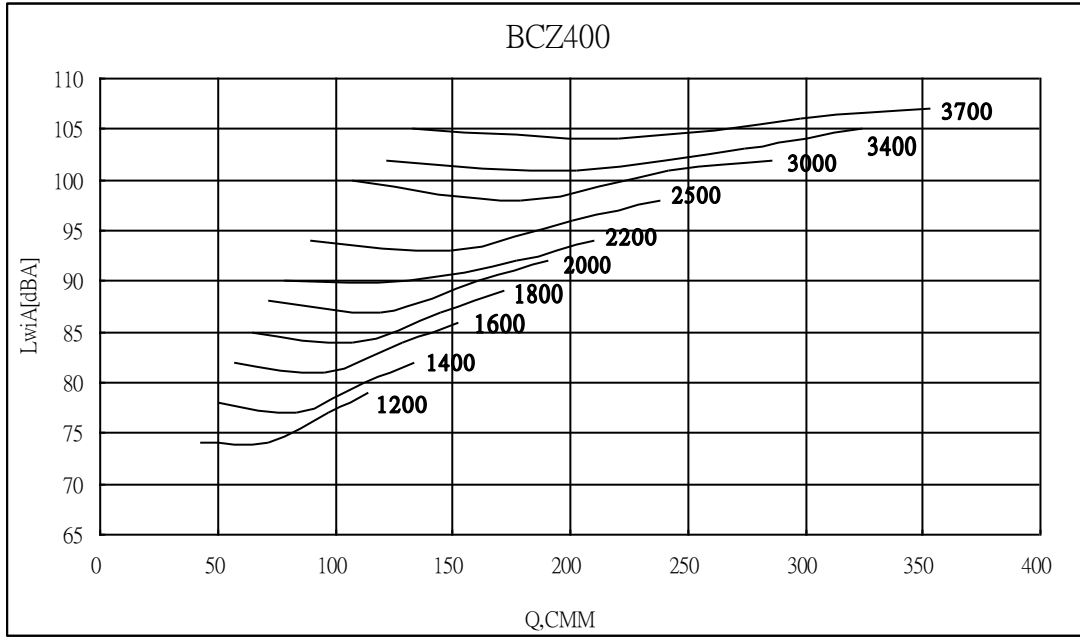

Sound Power [dB Ref 10-12 watts] %POF=(CMM*3531.5 / RPM x 3.57)

Inlet Sound Power, Lwi [Octave Band]

RPM	%POF	Octave Band								LwiA [dBA]
		63	125	250	500	1K	2K	4K	8K	
1200	94	80	79	81	76	71	70	66	52	79
	79	79	77	79	75	70	68	60	48	77
	59	81	77	76	71	67	65	57	52	74
	35	81	80	78	70	66	63	57	54	74
1600	94	87	83	87	83	78	77	76	64	86
	79	88	83	86	82	77	75	71	59	84
	59	89	83	84	78	73	73	67	61	81
	35	91	85	86	79	72	71	66	62	82
2000	94	90	90	92	89	85	82	81	73	92
	79	93	90	90	88	84	81	78	68	90
	59	92	91	89	84	80	78	74	67	87
	35	95	92	91	86	79	77	73	67	88
2500	94	99	95	94	97	92	88	86	83	98
	79	100	95	93	95	91	86	84	77	96
	59	99	96	92	93	87	83	81	74	93
	35	101	97	95	94	87	82	79	73	94
3000	94	104	102	96	102	97	92	90	89	102
	79	103	104	96	100	95	90	89	84	101
	59	101	104	96	98	92	86	86	80	98
	35	103	106	98	100	92	86	84	79	100
3700	94	109	104	104	106	102	98	95	95	107
	79	108	108	103	104	100	96	94	91	106
	59	106	106	104	103	97	93	91	87	104
	35	108	110	105	105	98	92	90	86	105

The sound power level ratings shown are in decibels. Referred to 10-12 watts calculated per AMCA Standard 301. Values shown are for inlet Lwi, LwiA sound power level for installation Type B: free inlet, ducted outlet. The A-weighted sound ratings shown have been calculated per AMCA Standard 301.

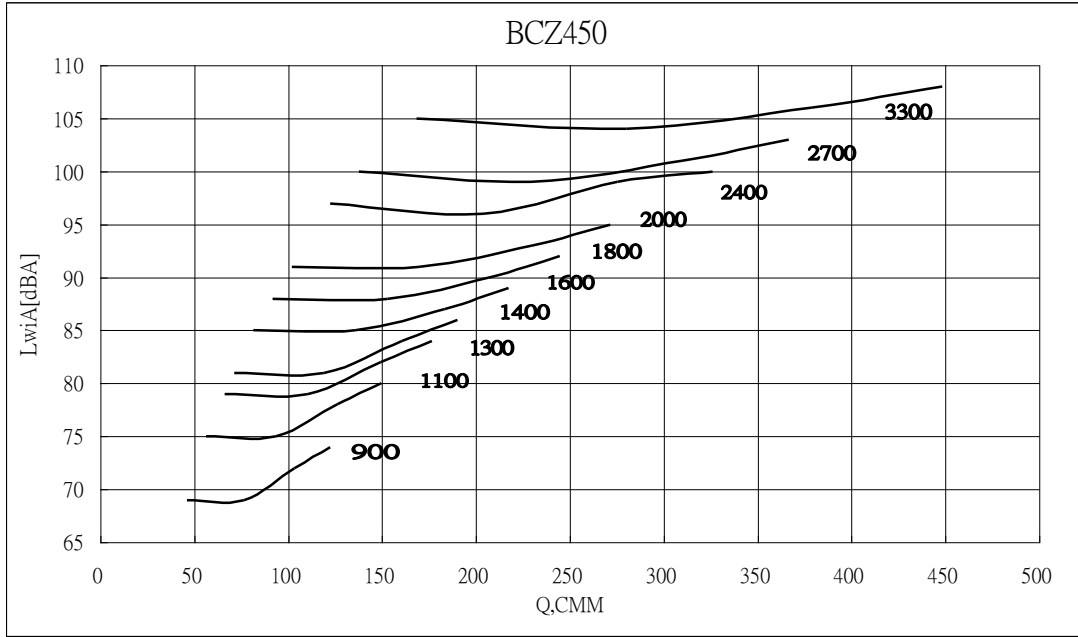

Sound Power [dB Ref 10-12 watts] %POF=(CMM*3531.5 / RPM x 5.09)

Inlet Sound Power, Lwi [Octave Band]

RPM	%POF	1 2 3 4 5 6 7 8 LwiA								
		63	125	250	500	1K	2K	4K	8K	[dBA]
1100	94	80	81	81	77	73	72	66	52	80
	79	80	80	79	75	71	69	60	49	78
	59	81	79	76	72	68	66	58	53	75
	35	82	82	78	71	67	64	58	55	75
1300	94	85	83	86	82	77	76	72	59	84
	79	85	82	84	80	75	73	67	55	82
	59	85	82	82	77	72	70	64	58	79
	35	87	85	83	76	71	69	63	60	79
1600	94	90	87	91	87	82	81	79	67	89
	79	92	87	89	85	80	79	75	63	87
	59	92	87	87	82	77	76	71	65	85
	35	94	89	89	82	76	75	70	65	85
2000	94	94	94	95	93	89	86	85	77	95
	79	96	94	94	91	87	84	81	71	93
	59	96	95	93	88	84	81	78	71	91
	35	99	95	95	89	83	80	76	71	91
2700	94	104	101	98	102	98	93	92	89	103
	79	104	101	98	100	96	91	90	83	101
	59	103	101	97	98	92	88	87	80	99
	35	105	104	100	100	92	87	85	79	100
3300	94	109	105	103	107	103	98	96	95	108
	79	108	106	103	105	101	96	95	91	106
	59	107	107	103	103	98	93	92	87	104
	35	109	110	105	105	98	92	90	86	105

The sound power level ratings shown are in decibels. Referred to 10-12 watts calculated per AMCA Standard 301. Values shown are for inlet Lwi, LwiA sound power level for installation Type B: free inlet, ducted outlet. The A-weighted sound ratings shown have been calculated per AMCA Standard 301.

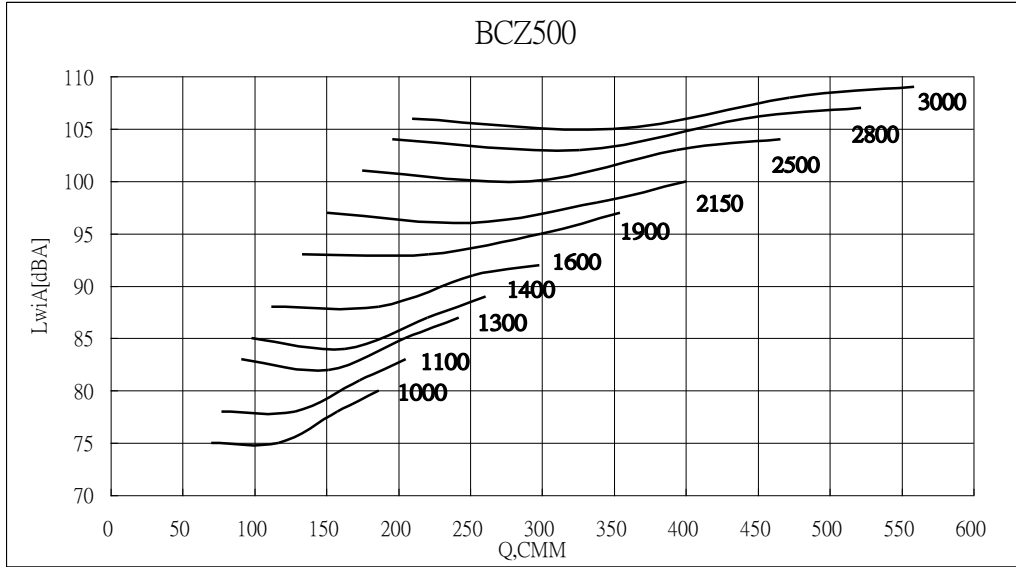

Sound Power [dB Ref 10-12 watts] %POF=(CMM*3531.5 / RPM x 6.98)

Inlet Sound Power, Lwi [Octave Band]

RPM	%POF	Octave Band								LwiA [dBA]
		1	2	3	4	5	6	7	8	
		63	125	250	500	1K	2K	4K	8K	
1100	94	84	85	84	80	76	75	69	56	83
	79	83	83	82	79	75	72	63	52	81
	59	84	82	79	75	72	69	62	56	78
	35	85	85	81	74	70	67	62	58	78
1300	94	88	86	89	85	80	79	76	62	87
	79	88	85	88	83	78	77	70	58	85
	59	89	85	85	80	75	74	67	62	82
	35	90	88	87	79	74	72	66	63	83
1600	94	94	90	94	90	85	84	82	70	92
	79	95	90	93	88	83	82	78	66	91
	59	95	90	91	85	80	79	74	68	88
	35	97	92	93	85	79	78	73	69	88
2150	94	99	98	99	99	94	91	90	83	100
	79	100	98	98	97	93	89	87	77	98
	59	101	99	97	94	89	86	83	76	96
	35	103	100	99	95	88	85	82	76	97
2500	94	106	102	101	103	99	94	93	89	104
	79	107	102	100	102	97	93	91	83	103
	59	106	103	99	99	94	90	88	80	100
	35	108	104	102	101	93	88	86	80	101
3000	94	110	109	103	108	104	99	97	96	109
	79	110	111	103	107	102	97	96	91	108
	59	108	110	102	105	99	93	93	87	105
	35	110	113	105	106	99	92	91	86	106

The sound power level ratings shown are in decibels. Referred to 10-12 watts calculated per AMCA Standard 301. Values shown are for inlet Lwi, LwiA sound power level for installation Type B: free inlet, ducted outlet. The A-weighted sound ratings shown have been calculated per AMCA Standard 301.

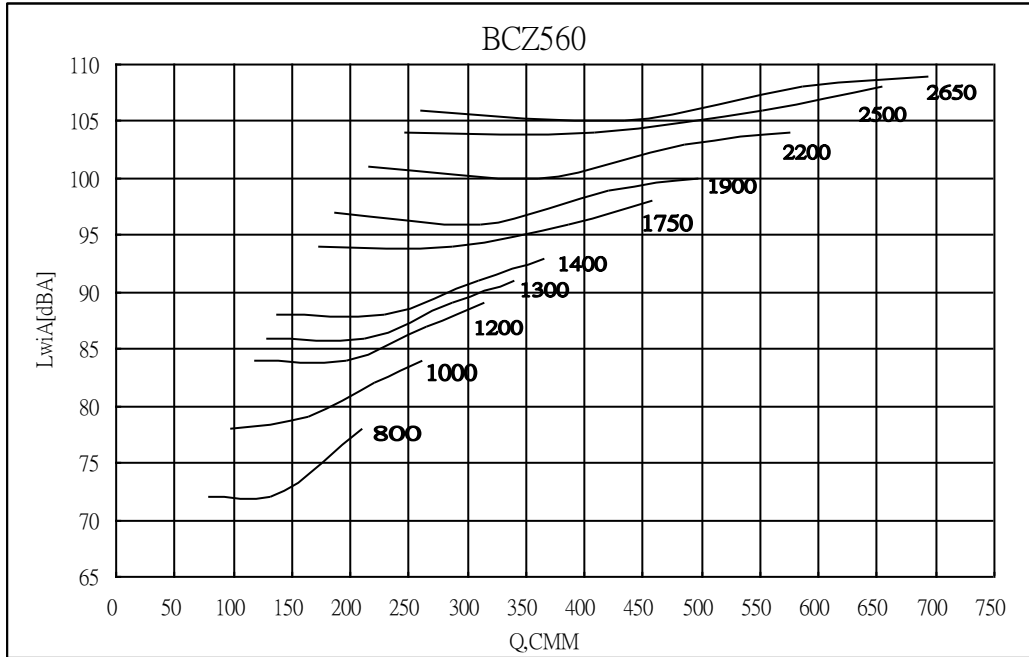

Sound Power [dB Ref 10-12 watts] %POF=(CMM*3531.5 / RPM x 9.8)

Inlet Sound Power, Lwi [Octave Band]

RPM	%POF	Octave Band								LwiA [dBA]
		1	2	3	4	5	6	7	8	
		63	125	250	500	1K	2K	4K	8K	
1000	94	85	87	84	81	77	77	68	55	84
	79	85	86	83	79	76	73	63	51	82
	59	86	84	79	75	73	70	62	57	79
	35	87	87	81	74	72	68	63	59	78
1200	94	90	89	91	86	82	81	76	62	89
	79	90	88	89	85	80	78	70	59	87
	59	91	87	87	81	77	75	67	62	84
	35	91	90	88	81	76	73	67	64	84
1400	94	94	91	95	90	85	84	82	68	93
	79	95	90	93	89	84	82	76	65	91
	59	95	90	91	85	80	79	73	67	88
	35	97	92	92	85	79	77	72	68	88
1750	94	98	97	99	96	91	89	88	78	98
	79	99	97	98	94	90	88	84	73	96
	59	99	97	96	91	86	85	80	74	94
	35	102	98	98	91	85	83	79	74	94
2200	94	104	102	103	103	99	95	94	88	104
	79	105	102	102	101	97	93	91	82	103
	59	105	103	101	98	93	90	87	80	100
	35	108	104	103	99	93	89	86	80	101
2650	94	110	107	105	108	104	99	98	95	109
	79	110	107	104	107	102	97	96	89	108
	59	110	107	103	104	99	94	93	86	105
	35	112	109	106	106	98	93	91	85	106

The sound power level ratings shown are in decibels. Referred to 10-12 watts calculated per AMCA Standard 301. Values shown are for inlet Lwi, LwiA sound power level for installation Type B: free inlet, ducted outlet. The A-weighted sound ratings shown have been calculated per AMCA Standard 301.

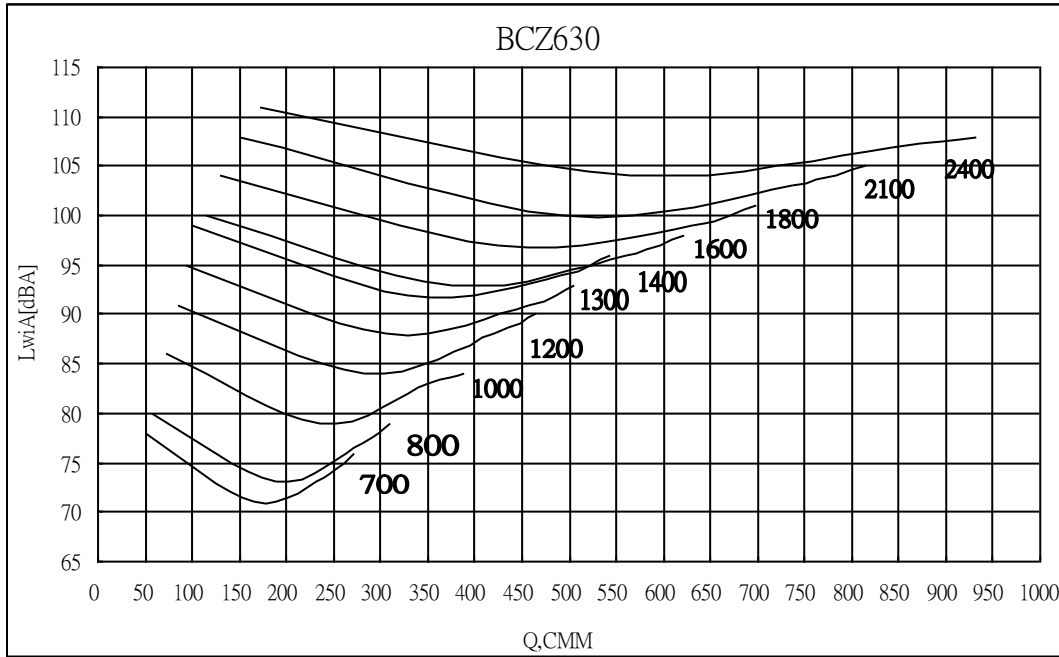

Sound Power [dB Ref 10-12 watts] %POF=(CMM*3531.5 / RPM x 14.65)

Inlet Sound Power, Lwi [Octave Band]

RPM	%POF	Octave Band								LwiA [dBA]
		1	2	3	4	5	6	7	8	
		63	125	250	500	1K	2K	4K	8K	
800	93	77	85	81	76	72	69	63	57	79
	84	75	84	79	74	70	66	61	57	77
	57	74	83	74	70	66	62	59	56	73
	17	86	90	83	75	71	66	61	56	80
1000	93	83	90	86	82	79	75	70	64	84
	84	81	88	85	80	77	72	68	64	83
	57	80	87	80	75	72	69	65	62	79
	17	91	95	89	81	78	73	67	63	86
1200	93	90	93	92	87	84	80	75	69	90
	84	87	92	91	86	82	77	73	69	88
	57	85	91	88	81	77	74	70	67	84
	17	95	100	96	88	82	78	73	68	91
1400	93	95	90	99	95	88	84	80	74	96
	84	93	88	98	93	86	82	77	73	94
	57	90	87	98	88	81	78	74	71	92
	17	100	98	105	98	86	83	77	72	99
1800	93	102	95	104	99	94	91	87	81	101
	84	100	93	103	98	93	89	84	80	99
	57	97	92	102	93	88	84	81	77	97
	17	106	103	110	102	93	90	85	79	104
2400	93	109	105	107	107	102	99	95	90	108
	84	107	103	106	106	101	97	92	88	107
	57	103	100	105	103	96	92	89	85	104
	17	112	111	114	111	103	98	93	88	111

The sound power level ratings shown are in decibels. Referred to 10-12 watts calculated per AMCA Standard 301. Values shown are for inlet Lwi, LwiA sound power level for installation Type B: free inlet, ducted outlet. The A-weighted sound ratings shown have been calculated per AMCA Standard 301.

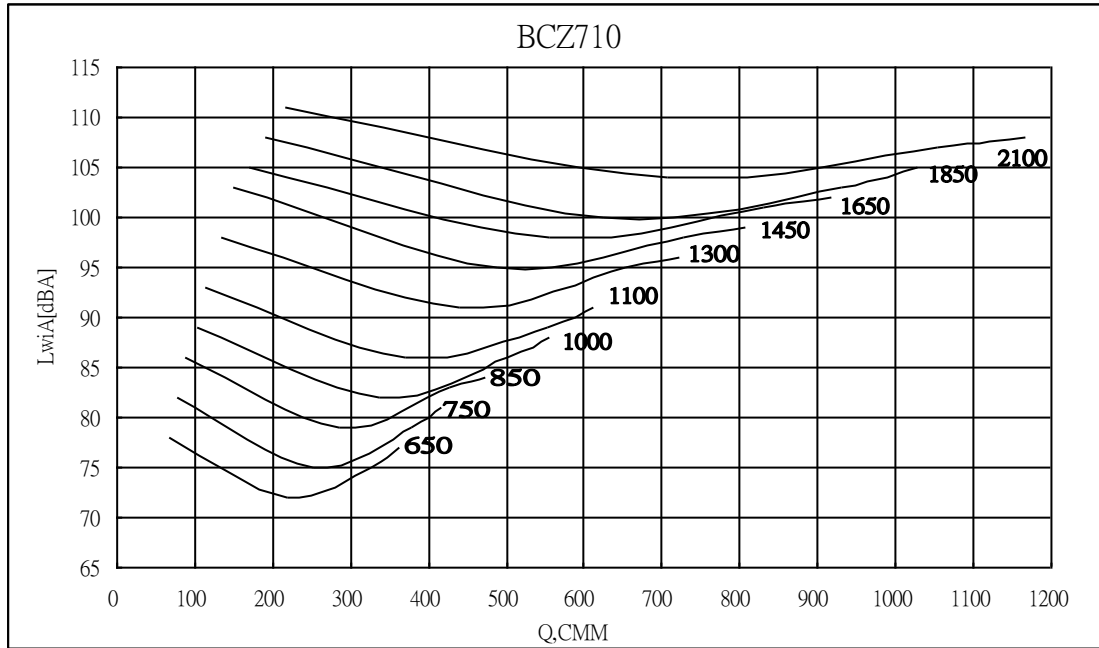

Sound Power [dB Ref 10⁻¹² watts] %POF=(CMM*3531.5 / RPM x 20.97)

Inlet Sound Power, Lwi [Octave Band]

RPM	%POF	Octave Band								LwiA [dBA]
		1	2	3	4	5	6	7	8	
		63	125	250	500	1K	2K	4K	8K	
750	93	80	87	83	78	74	70	64	59	81
	84	78	86	82	76	72	68	63	59	79
	57	77	85	76	72	68	64	61	58	75
	17	88	93	86	77	73	68	63	58	82
850	93	82	91	87	81	78	74	68	63	84
	84	80	90	85	80	76	71	67	62	83
	57	79	90	80	75	71	68	64	61	79
	17	90	97	89	80	77	72	66	62	86
1000	93	87	93	90	85	82	78	73	68	88
	84	85	92	88	84	80	75	71	67	86
	57	83	91	84	79	76	72	69	66	82
	17	94	99	92	85	81	76	71	66	89
1300	93	96	95	99	94	89	85	81	75	96
	84	94	93	98	93	88	83	79	74	95
	57	92	92	97	88	83	79	76	72	91
	17	101	102	104	96	88	84	79	74	98
1650	93	104	97	105	101	95	92	88	82	102
	84	101	95	104	99	94	90	85	81	101
	57	98	94	103	94	89	86	82	78	98
	17	107	105	110	103	94	91	86	80	105
2100	93	110	104	110	107	101	99	95	90	108
	84	108	102	109	105	100	97	92	88	107
	57	104	100	109	101	95	92	89	85	104
	17	113	111	116	110	101	98	93	88	111

The sound power level ratings shown are in decibels. Referred to 10-12 watts calculated per AMCA Standard 301. Values shown are for inlet Lwi, LwiA sound power level for installation Type B: free inlet, ducted outlet. The A-weighted sound ratings shown have been calculated per AMCA Standard 301.

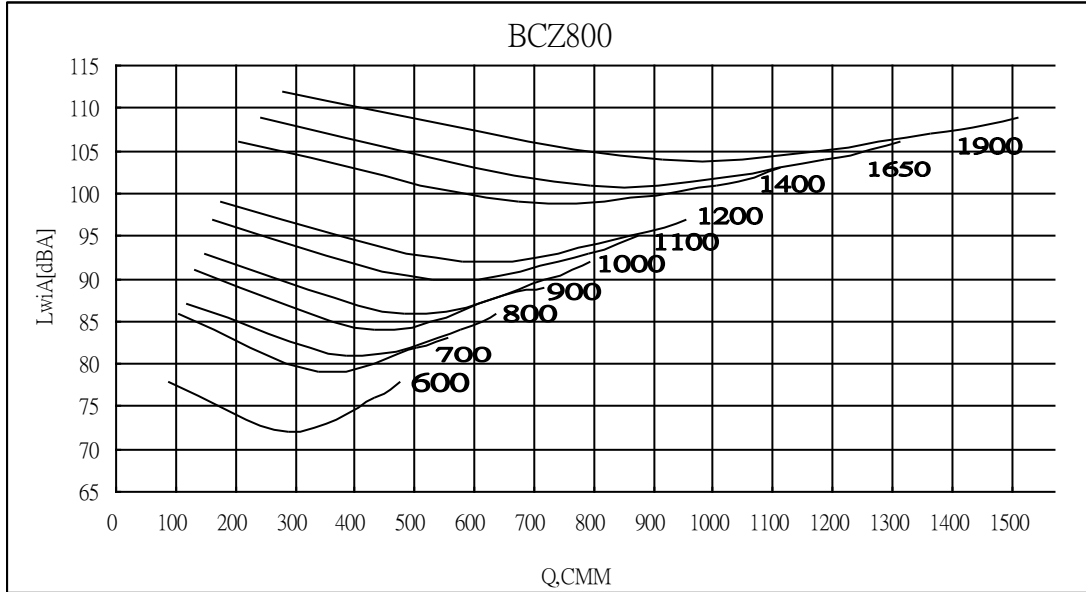

Sound Power [dB Ref 10-12 watts] %POF=(CMM*3531.5 / RPM x 30)

Inlet Sound Power, Lwi [Octave Band]

RPM	%POF	Octave Band								LwiA [dBA]
		1	2	3	4	5	6	7	8	
		63	125	250	500	1K	2K	4K	8K	
800	93	85	92	88	83	80	76	70	64	86
	84	83	91	86	82	78	73	68	64	84
	56	82	90	81	77	73	70	66	63	81
	17	93	98	90	82	79	73	68	64	87
1000	93	91	97	94	89	86	82	77	71	92
	84	89	96	92	87	84	79	75	71	90
	56	87	94	87	82	79	76	72	69	86
	17	98	102	96	88	85	80	75	70	93
1200	93	97	100	99	95	91	87	83	77	97
	84	95	99	98	93	89	84	80	76	95
	56	93	98	95	88	84	81	77	74	92
	17	103	107	103	95	90	85	80	75	99
1400	93	102	97	106	102	95	91	87	81	103
	84	100	96	106	100	93	89	85	80	101
	56	98	94	106	95	88	85	81	78	99
	17	107	105	112	105	94	90	85	79	106
1650	93	107	100	109	104	99	96	92	86	106
	84	105	98	108	102	98	94	89	84	104
	56	102	97	107	97	93	89	86	82	101
	17	111	109	114	107	98	95	89	84	109
1900	93	111	104	111	107	103	100	96	90	109
	84	109	102	110	106	101	98	93	89	107
	56	105	101	109	101	96	93	89	86	104
	17	114	112	117	110	102	99	94	88	112

The sound power level ratings shown are in decibels. Referred to 10-12 watts calculated per AMCA Standard 301. Values shown are for inlet Lwi, LwiA sound power level for installation Type B: free inlet, ducted outlet. The A-weighted sound ratings shown have been calculated per AMCA Standard 301.

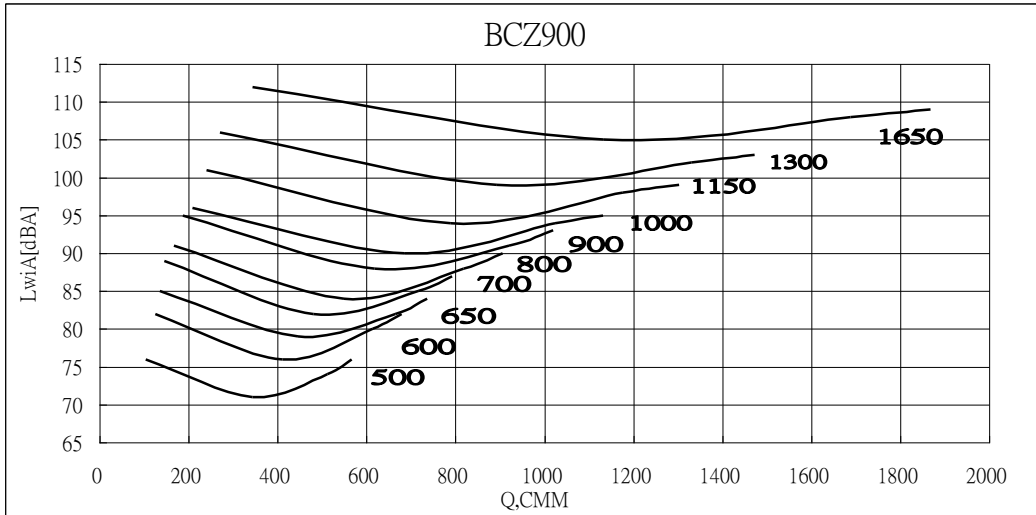

Sound Power [dB Ref 10-12 watts] %POF=(CMM*3531.5 / RPM x 42.71)

Inlet Sound Power, Lwi [Octave Band]

RPM	%POF	Octave Band								LwiA [dBA]
		1	2	3	4	5	6	7	8	
		63	125	250	500	1K	2K	4K	8K	
600	93	88	88	83	79	75	71	65	59	82
	84	87	87	81	78	73	69	64	60	80
	57	87	84	76	73	69	66	63	59	76
	17	95	92	84	78	74	69	64	59	82
700	93	86	95	90	83	80	76	70	64	87
	84	84	94	88	82	77	73	68	64	85
	57	83	94	83	77	74	70	66	63	82
	17	94	101	93	82	78	73	68	63	89
800	93	88	96	92	87	83	79	74	68	90
	84	86	95	90	85	81	77	72	68	88
	57	85	94	85	81	77	73	70	67	84
	17	96	101	94	86	82	77	72	67	91
900	93	91	100	95	90	86	83	77	72	93
	84	89	99	93	88	85	80	75	71	91
	57	88	98	89	84	80	76	73	70	88
	17	99	105	98	89	85	80	75	71	95
1000	93	94	100	97	92	89	85	81	75	95
	84	92	99	95	91	88	83	79	74	94
	57	91	98	91	86	83	79	76	73	90
	17	102	106	100	92	88	84	78	74	96
1300	93	104	102	106	102	96	93	89	82	103
	84	101	100	105	100	95	90	86	81	102
	57	99	99	104	95	90	87	83	80	99
	17	109	109	111	104	95	91	86	81	106
1650	84	111	104	112	108	103	99	95	90	109
	57	109	102	111	106	101	97	93	88	108
	17	106	101	110	101	96	93	89	86	105
	93	115	112	118	110	102	98	93	88	112

The sound power level ratings shown are in decibels. Referred to 10-12 watts calculated per AMCA Standard 301. Values shown are for inlet Lwi, LwiA sound power level for installation Type B: free inlet, ducted outlet. The A-weighted sound ratings shown have been calculated per AMCA Standard 301.

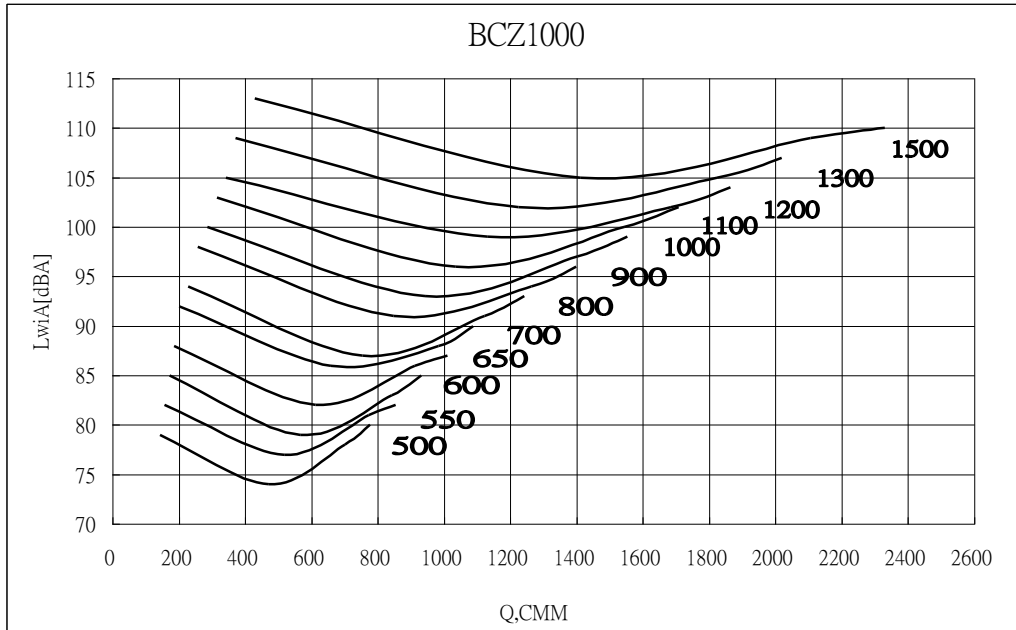

Sound Power [dB Ref 10-12 watts] %POF=(CMM*3531.5 / RPM x 58.59)

Inlet Sound Power, Lwi [Octave Band]

RPM	%POF	Octave Band								LwiA [dBA]
		1	2	3	4	5	6	7	8	
500	93	63	125	250	500	1K	2K	4K	8K	80
	84	63	83	79	76	71	67	63	57	78
	57	66	79	74	71	67	64	61	57	74
	17	94	88	80	77	72	66	62	57	79
600	93	63	125	250	500	1K	2K	4K	8K	85
	84	63	90	85	81	76	72	68	63	83
	57	66	87	79	76	73	69	66	62	79
	17	98	95	87	81	77	72	67	62	85
800	93	63	125	250	500	1K	2K	4K	8K	93
	84	63	98	93	89	84	80	75	71	91
	57	66	89	88	84	80	76	73	70	87
	17	100	105	97	89	85	80	75	70	94
1000	93	63	125	250	500	1K	2K	4K	8K	99
	84	63	102	99	94	91	86	82	78	97
	57	66	101	94	89	86	83	79	76	93
	17	105	109	103	95	92	87	81	77	100
1200	93	63	125	250	500	1K	2K	4K	8K	104
	84	63	106	105	100	96	91	87	83	102
	57	66	105	102	95	91	88	84	81	99
	17	110	114	110	102	96	92	87	82	105
1500	93	63	125	250	500	1K	2K	4K	8K	110
	84	63	103	112	107	102	98	93	89	109
	57	66	102	111	102	97	94	90	86	105
	17	115	113	118	111	102	99	93	88	113

The sound power level ratings shown are in decibels. Referred to 10-12 watts calculated per AMCA Standard 301. Values shown are for inlet Lwi, LwiA sound power level for installation Type B: free inlet, ducted outlet. The A-weighted sound ratings shown have been calculated per AMCA Standard 301.

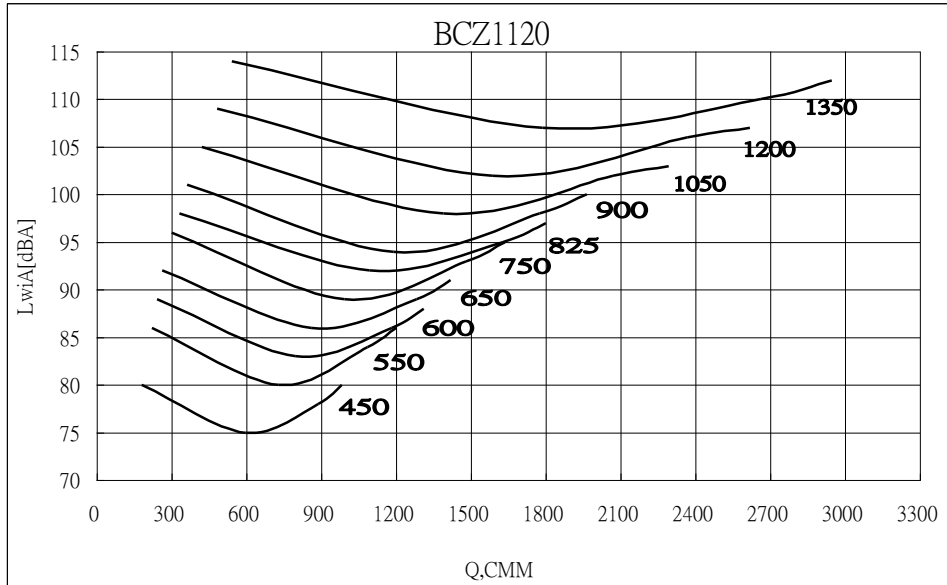

Sound Power [dB Ref 10-12 watts] %POF=(CMM*3531.5 / RPM x 82.32)

Inlet Sound Power, Lwi [Octave Band]

RPM	%POF	Octave Band								LwiA [dBA]
		1	2	3	4	5	6	7	8	
		63	125	250	500	1K	2K	4K	8K	
450	93	92	87	81	78	74	69	63	57	80
	84	91	85	80	76	71	67	63	58	78
	56	90	80	75	72	68	64	62	57	75
	17	98	90	80	77	72	67	62	57	80
550	93	96	92	86	84	80	75	69	63	86
	84	95	91	85	82	77	73	69	64	84
	56	95	86	80	77	74	70	67	63	80
	17	102	96	86	83	78	73	68	63	86
650	93	93	98	93	88	84	80	74	68	91
	84	92	97	91	86	82	78	73	69	89
	56	91	96	86	82	78	75	71	68	86
	17	101	103	95	87	83	77	73	68	92
825	93	95	104	99	94	91	87	81	76	97
	84	93	103	98	93	89	84	80	75	95
	56	93	102	93	88	84	81	77	74	92
	17	104	109	102	93	90	84	79	75	98
1050	93	103	109	106	100	97	93	89	83	103
	84	100	108	104	99	96	91	87	82	102
	56	99	107	100	94	91	87	84	81	98
	17	109	115	108	100	96	92	86	82	105
1350	93	112	108	115	110	104	100	96	90	112
	84	109	106	114	108	102	98	94	89	110
	56	107	105	113	103	98	94	91	87	107
	17	116	116	120	113	103	99	94	89	114

The sound power level ratings shown are in decibels. Referred to 10-12 watts calculated per AMCA Standard 301. Values shown are for inlet Lwi, LwiA sound power level for installation Type B: free inlet, ducted outlet. The A-weighted sound ratings shown have been calculated per AMCA Standard 301.

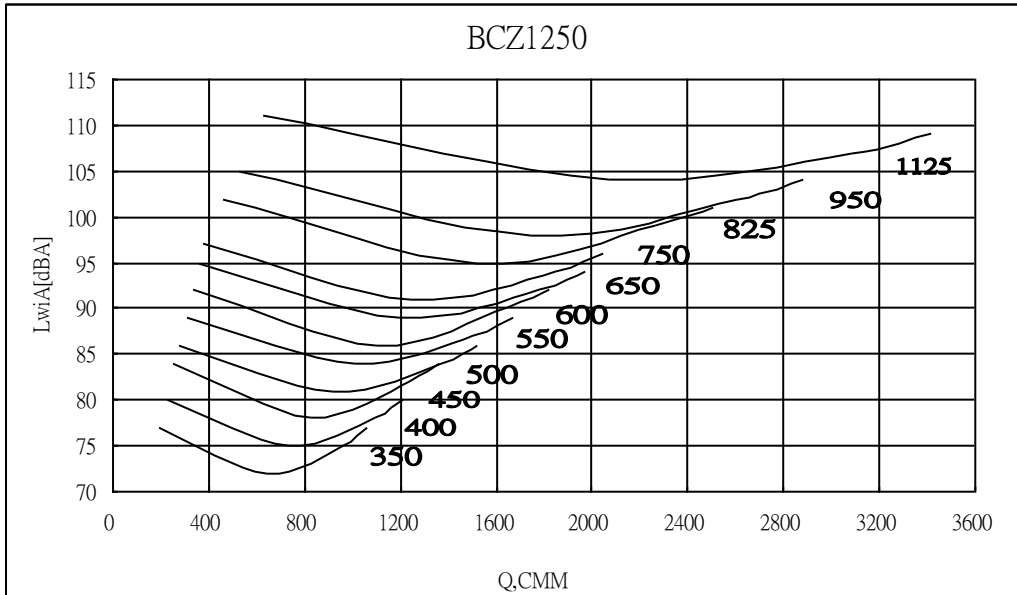

Sound Power [dB Ref 10-12 watts] %POF=(CMM*3531.5 / RPM x 114.44)

Inlet Sound Power, Lwi [Octave Band]

RPM	%POF	Octave Band								LwiA [dBA]
		1	2	3	4	5	6	7	8	
400	93	91	87	82	78	74	68	63	57	80
	84	90	85	80	76	71	67	63	58	78
	56	89	80	75	72	68	65	62	58	75
	17	96	89	81	77	72	67	62	57	80
500	93	95	92	87	84	80	75	70	64	86
	84	94	90	86	83	78	74	69	64	84
	56	93	86	81	78	74	71	68	64	81
	17	101	94	87	83	78	73	69	63	86
600	93	98	98	93	89	85	81	75	69	92
	84	97	97	91	88	83	79	74	70	90
	56	97	94	86	83	79	76	73	69	86
	17	105	102	94	88	84	79	74	69	92
750	93	97	105	100	95	91	88	82	76	98
	84	95	103	99	94	89	85	80	76	96
	56	94	102	94	89	85	82	78	75	93
	17	105	110	103	94	90	85	80	75	99
950	93	103	109	106	101	98	94	89	83	104
	84	100	108	104	100	96	91	87	83	102
	56	99	107	99	95	92	88	84	81	98
	17	110	115	108	100	97	92	87	82	105
1125	93	108	115	111	105	103	99	94	88	109
	84	106	114	110	104	101	96	92	88	107
	56	104	115	106	99	96	93	89	86	104
	17	115	122	115	105	102	97	92	87	111

The sound power level ratings shown are in decibels. Referred to 10-12 watts calculated per AMCA Standard 301. Values shown are for inlet Lwi, LwiA sound power level for installation Type B: free inlet, ducted outlet. The A-weighted sound ratings shown have been calculated per AMCA Standard 301.

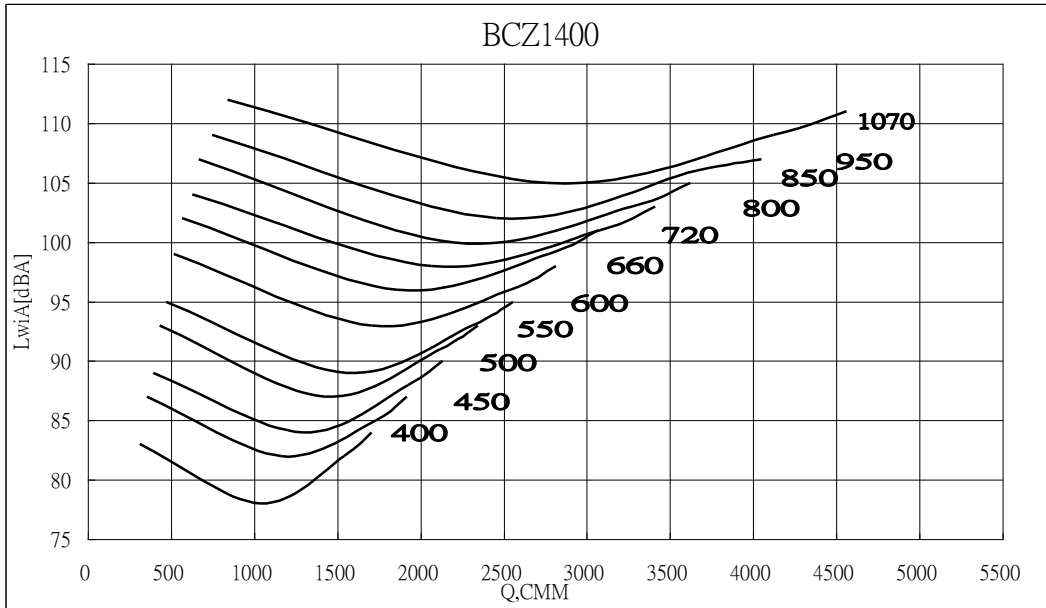

Sound Power [dB Ref 10-12 watts] %POF=(CMM*3531.5 / RPM x 160.77)

Inlet Sound Power, Lwi [Octave Band]

RPM	%POF	Octave Band								LwiA [dBA]
		1	2	3	4	5	6	7	8	
		63	125	250	500	1K	2K	4K	8K	
400	93	94	90	85	82	78	72	66	60	84
	84	93	88	84	80	75	70	66	61	82
	57	92	83	79	75	72	68	65	61	78
	17	100	92	84	81	75	70	66	60	83
500	93	99	95	91	88	84	79	73	67	90
	84	98	94	89	86	81	77	73	68	88
	57	97	89	84	81	78	74	71	67	84
	17	105	98	90	87	82	77	72	67	89
600	93	102	102	96	93	89	85	79	73	95
	84	101	100	95	91	86	82	78	73	93
	57	100	97	90	86	83	79	76	72	89
	17	109	105	97	92	87	82	77	72	95
800	93	102	109	105	100	97	93	87	81	103
	84	100	108	103	99	95	90	85	81	101
	57	99	107	98	94	90	87	83	80	98
	17	110	115	107	99	96	90	85	81	104
950	93	106	113	109	105	101	98	92	87	107
	84	104	112	108	103	99	95	91	86	106
	57	103	111	103	98	95	91	88	85	102
	17	114	119	112	104	100	95	90	86	109
1070	93	110	116	113	108	105	101	96	90	111
	84	108	115	111	106	103	98	94	90	109
	57	106	115	107	101	98	95	91	88	105
	17	117	122	116	107	104	99	94	89	112

The sound power level ratings shown are in decibels. Referred to 10-12 watts calculated per AMCA Standard 301. Values shown are for inlet Lwi, LwiA sound power level for installation Type B: free inlet, ducted outlet. The A-weighted sound ratings shown have been calculated per AMCA Standard 301.

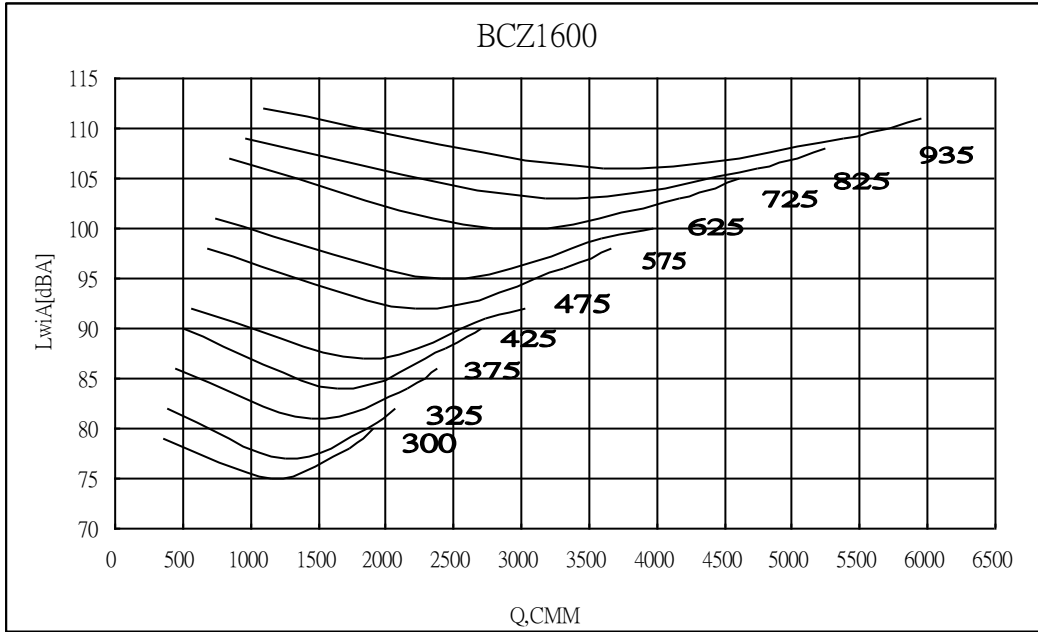

Sound Power [dB Ref 10-12 watts] %POF=(CMM*3531.5 / RPM x 239.99)

Inlet Sound Power, Lwi [Octave Band]

RPM	%POF	Octave Band								LwiA [dBA]
		1	2	3	4	5	6	7	8	
		63	125	250	500	1K	2K	4K	8K	
300	93	91	85	82	78	73	68	62	55	80
	84	89	84	80	75	71	67	62	57	78
	57	86	79	75	72	68	65	61	57	75
	17	94	86	81	76	71	66	61	56	79
375	93	97	93	88	84	80	74	68	62	86
	84	96	91	86	82	77	73	68	63	84
	57	95	86	81	78	74	71	67	63	81
	17	103	95	86	83	77	72	68	62	86
475	93	102	98	93	90	86	81	76	70	92
	84	101	96	92	89	84	79	75	70	91
	57	100	92	87	84	80	77	74	70	87
	17	108	101	93	89	84	79	75	69	92
575	93	107	105	99	96	92	87	81	75	98
	84	106	103	97	94	89	85	81	76	96
	57	106	99	92	89	86	82	79	75	92
	17	113	108	99	95	90	85	80	75	98
725	93	104	112	108	102	98	94	88	83	105
	84	102	111	106	100	96	92	87	83	103
	57	101	111	101	95	92	88	85	81	100
	17	112	118	110	101	97	91	86	82	107
825	93	106	115	110	105	102	98	92	86	108
	84	104	114	108	104	100	95	90	86	106
	57	103	113	103	99	95	92	88	85	103
	17	115	120	113	104	100	95	90	86	109

The sound power level ratings shown are in decibels. Referred to 10-12 watts calculated per AMCA Standard 301. Values shown are for inlet Lwi, LwiA sound power level for installation Type B: free inlet, ducted outlet. The A-weighted sound ratings shown have been calculated per AMCA Standard 301.

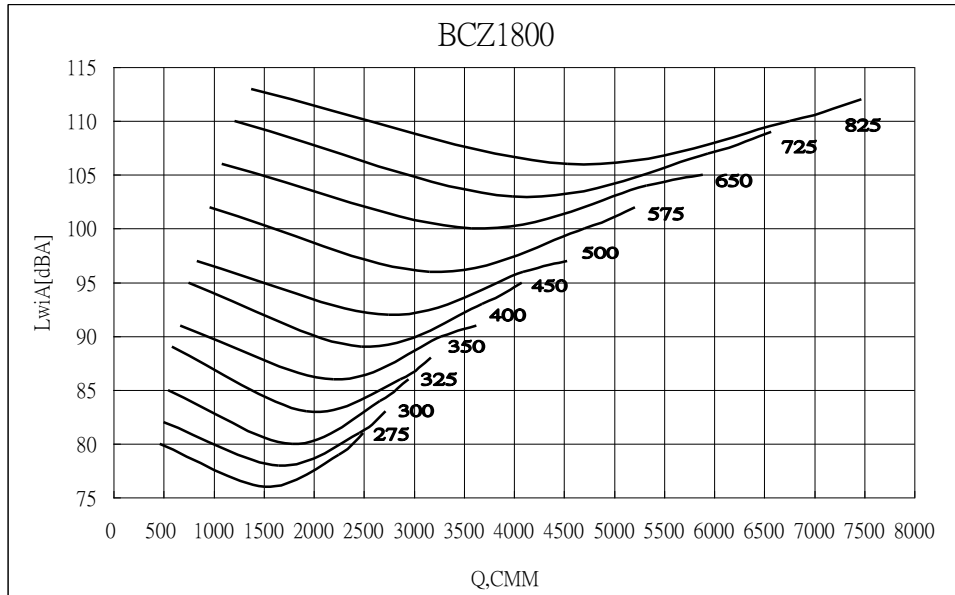

Sound Power [dB Ref 10-12 watts] %POF=(CMM*3531.5 / RPM x 341.7)

Inlet Sound Power, Lwi [Octave Band]

RPM	%POF	1	2	3	4	5	6	7	8	LwiA [dBA]
		63	125	250	500	1K	2K	4K	8K	
275	93	92	86	83	79	74	69	63	56	81
	84	90	84	81	76	72	68	63	58	79
	57	86	79	76	73	69	66	62	58	76
	17	95	85	82	77	72	67	62	57	80
325	93	97	92	87	84	79	73	68	61	86
	84	96	91	86	81	77	72	68	63	84
	57	95	86	81	78	74	71	67	63	80
	17	102	94	86	82	77	72	67	62	85
400	93	102	98	93	89	85	79	74	68	91
	84	101	96	91	87	83	78	74	69	90
	57	100	91	86	83	79	76	73	69	86
	17	107	100	92	88	83	78	73	68	91
575	93	110	108	102	99	95	91	85	79	102
	84	110	106	101	98	93	89	84	79	100
	57	109	103	96	93	89	86	83	79	96
	17	117	111	102	98	94	88	84	79	102
725	93	108	116	111	105	102	98	92	86	109
	84	106	115	109	104	99	95	90	86	107
	57	105	114	104	99	96	92	88	85	103
	17	116	121	114	104	100	95	90	85	110
825	93	110	118	114	109	105	101	96	90	112
	84	108	117	112	107	103	99	94	90	110
	57	107	116	107	102	99	95	92	89	106
	17	118	124	116	108	104	99	94	89	113

The sound power level ratings shown are in decibels. Referred to 10-12 watts calculated per AMCA Standard 301. Values shown are for inlet Lwi, LwiA sound power level for installation Type B: free inlet, ducted outlet. The A-weighted sound ratings shown have been calculated per AMCA Standard 301.

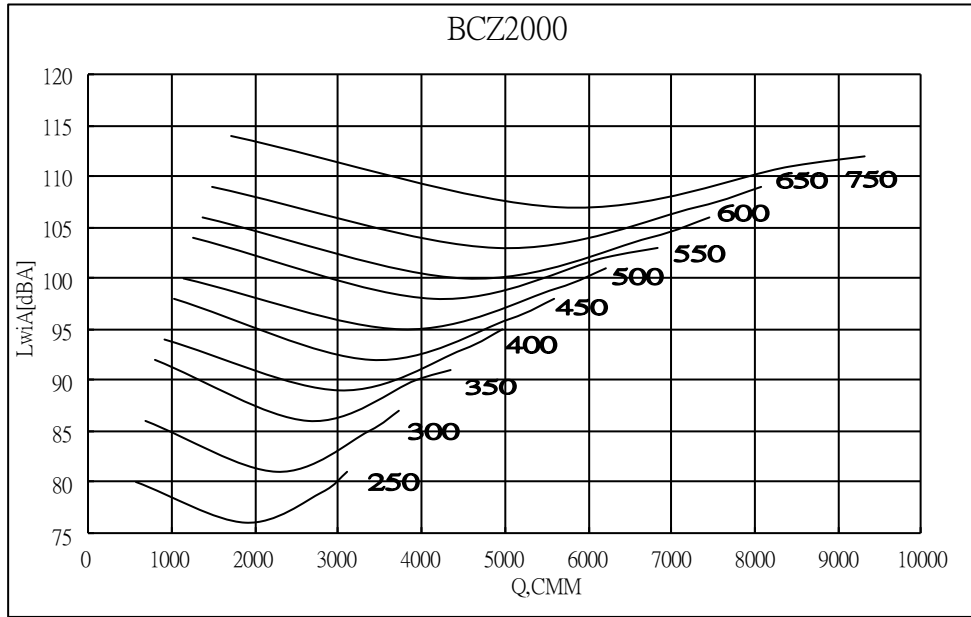

Sound Power [dB Ref 10-12 watts] %POF=(CMM*3531.5 / RPM x 468.73)

Inlet Sound Power, Lwi [Octave Band]

RPM	%POF	Octave Band								LwiA [dBA]
		1	2	3	4	5	6	7	8	
		63	125	250	500	1K	2K	4K	8K	
250	93	91	87	84	80	75	69	63	57	81
	84	90	85	82	77	73	69	63	58	79
	57	85	80	77	73	70	67	63	59	76
	17	94	86	82	78	72	68	63	57	80
350	93	104	99	93	89	85	79	73	67	91
	84	103	98	91	87	82	78	73	68	90
	57	103	92	86	83	79	76	72	68	86
	17	110	102	91	88	82	77	72	67	92
450	93	109	104	99	96	92	86	81	75	98
	84	108	103	98	94	89	85	81	75	96
	57	108	98	93	89	86	82	79	75	92
	17	115	107	98	95	90	84	80	75	98
550	93	113	110	104	101	97	93	87	81	103
	84	113	108	102	100	95	91	86	81	102
	57	112	104	97	95	91	88	85	81	98
	17	120	113	104	100	95	90	86	80	104
650	93	111	116	111	106	102	98	92	86	109
	84	110	114	109	104	99	95	91	86	107
	57	109	113	104	99	96	92	89	85	103
	17	118	120	113	105	101	95	90	85	109
750	93	111	119	115	109	106	102	96	90	112
	84	109	118	113	108	104	99	95	90	111
	57	108	117	108	103	100	96	92	89	107
	17	119	124	117	108	105	99	94	90	114

The sound power level ratings shown are in decibels. Referred to 10-12 watts calculated per AMCA Standard 301. Values shown are for inlet Lwi, LwiA sound power level for installation Type B: free inlet, ducted outlet. The A-weighted sound ratings shown have been calculated per AMCA Standard 301.



BCZ 250-450 'L'

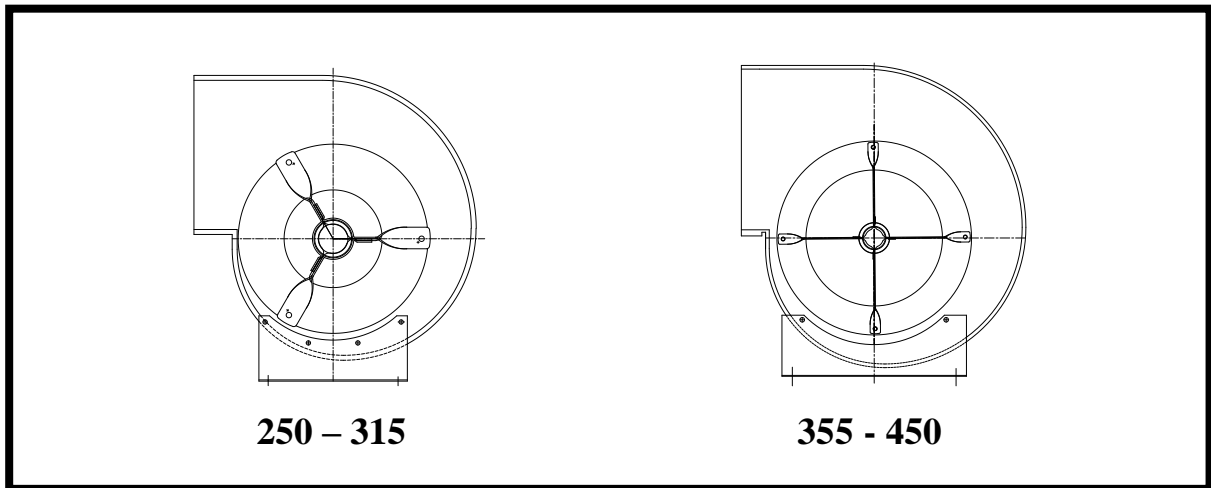
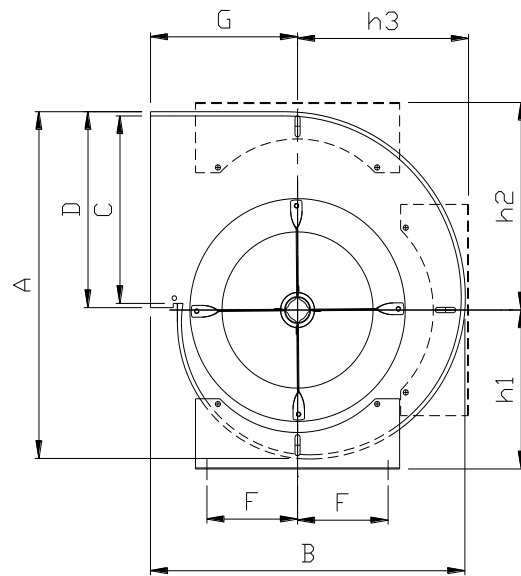
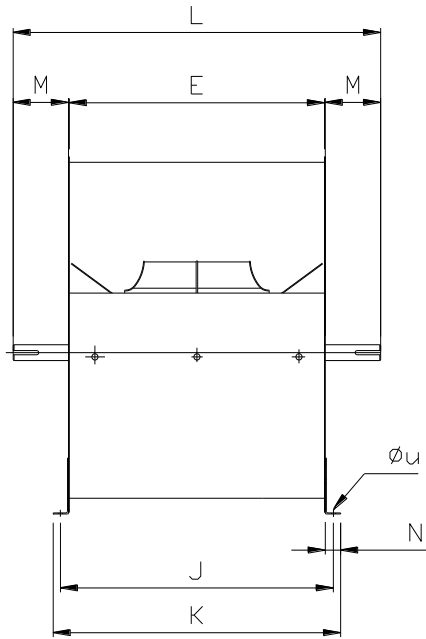

Model	A	B	C	D	E	F	G	H1	H2	H3	J	K	L	M	N	t	t1	W	Z	Φ_d	Φ_u
250	461	455	250	265	300	105	225	231	273	234	334	362	475	87	30	6	6	30	22.5	20	10
280	517	503	280	297	336	140	245	255	307	270	364	392	529	98	30	8	7	40	28	25	10
315	580	555	315	333	378	140	265	272	344	295	404	432	570	99	30	8	7	40	28	25	10
355	657	616	355	371	500	177.5	288	301	393	335	535	563	720	108	30	8	7	50	33	30	12
400	738	688	400	421	560	177.5	320	337	425	385	595	623	780	108	30	8	7	50	33	30	12
450	826	753	450	473	640	225	340	357	480	419	676	704	860	108	30	10	8	50	38	35	12

All dimensions in mm.



BCZ 250-630 'M'

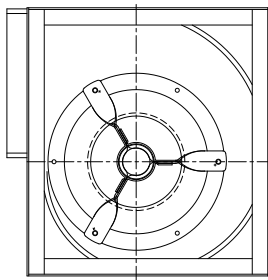
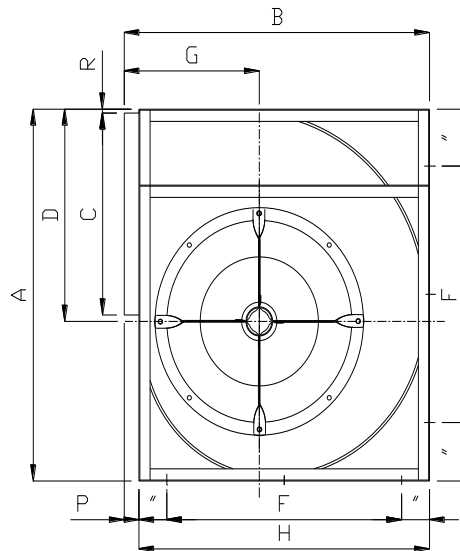
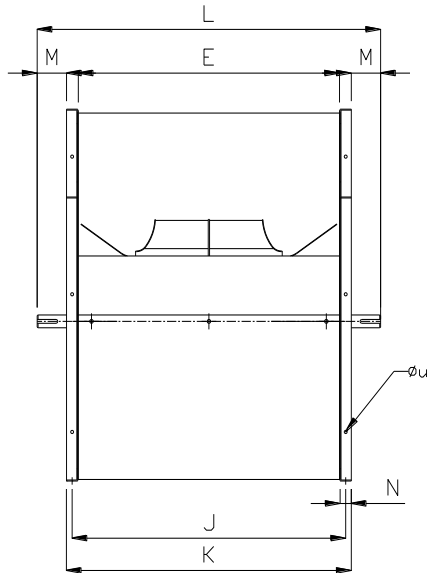

250 – 315

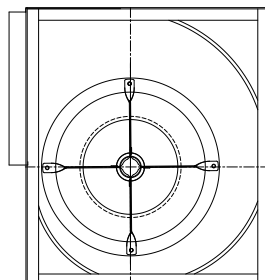

355 – 400

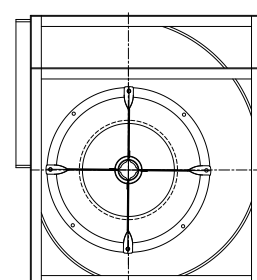

450 - 630

Model	A	B	C	D	E	F	G	H	J	K	L	M	N	P	R	t	T1	W	Z	Φd	Φu
250	474	460	250	271	300	250	225	425	327	352	475	62	25	35	6	6	6	35	22.5	20	10
280	519	505	280	300	336	280	245	470	362	392	529	68	30	35	11	8	7	45	28	25	14
315	582	560	315	338	378	280	265	522	402	432	570	69	30	35	13	8	7	45	28	25	14
355	662	620	355	378	500	425	288	580	533	563	720	78	30	40	11	8	7	50	33	30	14
400	743	690	408	423	560	470	320	650	593	623	780	78	30	40	10	8	7	50	33	30	14
450	832	760	458	475	640	532	345	715	675	704	860	78	30	45	10	10	8	50	38	35	14
500	930	855	508	530	700	625	390	805	743	780	960	90	38	50	14	10	8	60	43	35	14
560	1031	945	586	568	790	700	430	895	833	870	1060	98	38	50	8	12	8	70	43	40	14
630	1160	1040	630	662	890	800	460	990	932	971	1170	100	38	50	12	12	8	70	43	40	14

All dimensions in mm.



BCZ 250-1000 'H'

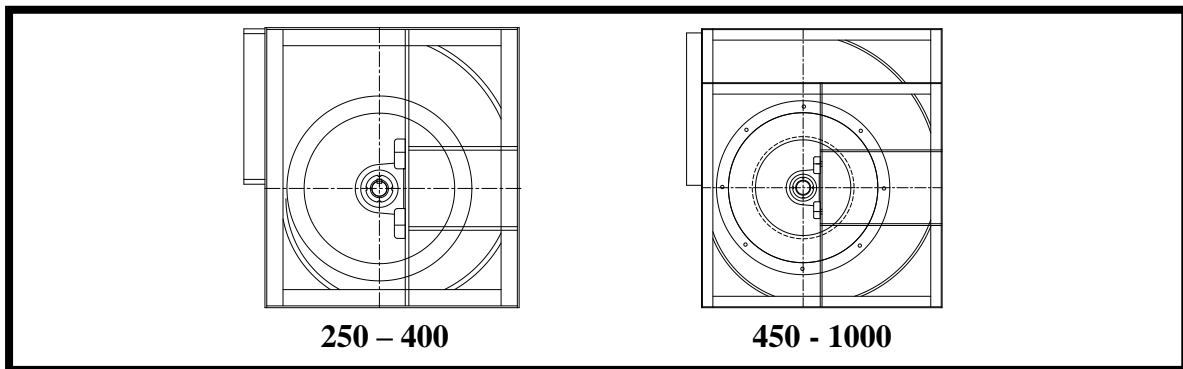
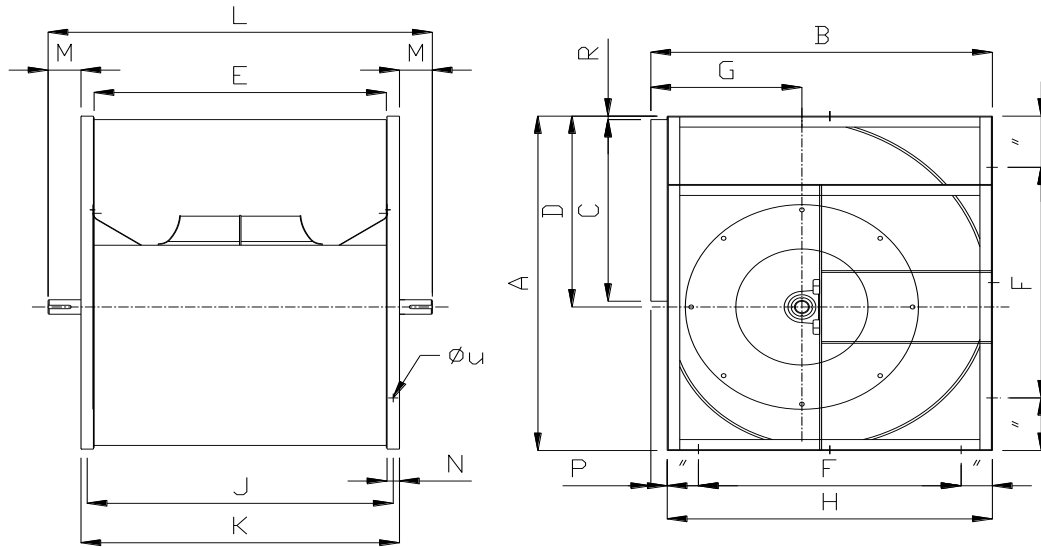

Model	A	B	C	D	E	F	G	H	J	K	L	M	N	P	R	t	t1	W	Z	Φd	Φu
250	474	460	250	271	300	250	225	425	327	362	528	83	25	35	6	8	7	40	28	25	14
280	519	505	280	298	336	280	245	470	362	392	560	84	30	35	9	8	7	40	33	30	14
315	582	560	315	334	378	280	265	522	405	432	600	84	30	35	8.5	8	7	40	33	30	14
355	662	620	355	378	500	425	288	580	541	563	749	93	30	40	11	10	8	50	38	35	14
400	743	690	408	423	560	470	320	650	593	623	809	93	30	40	10	10	8	50	38	35	14
450	832	760	458	475	640	532	345	715	682	703	933	115	30	45	10	12	8	70	43	40	14
500	930	855	508	530	700	625	390	805	742	780	1018	119	38	50	14	14	8	70	48.5	45	14
560	1031	945	586	568	790	700	430	895	832	870	1136	133	38	50	8	14	9	90	53.5	50	14
630	1160	1040	630	662	890	800	460	990	932	970	1236	133	38	50	12	14	9	90	53.5	50	14
710	1300	1150	710	745	1000	940	502	1100	1054	1104	1386	141	50	50	12	18	11	90	53.5	60	18
800	1460	1300	800	835	1130	1080	565	1240	1189	1234	1516	141	50	60	10	18	11	90	64	60	18
900	1643	1395	900	943	1270	1230	635	1395	1327	1374	1710	168	50	60	13	18	11	110	64	65	18
1000	1815	1600	1000	1043	1400	1380	695	1540	1459	1504	1862	179	50	60	13	20	12	110	74.5	70	18

All dimensions in mm.



BCZ 1120-2000 'H'

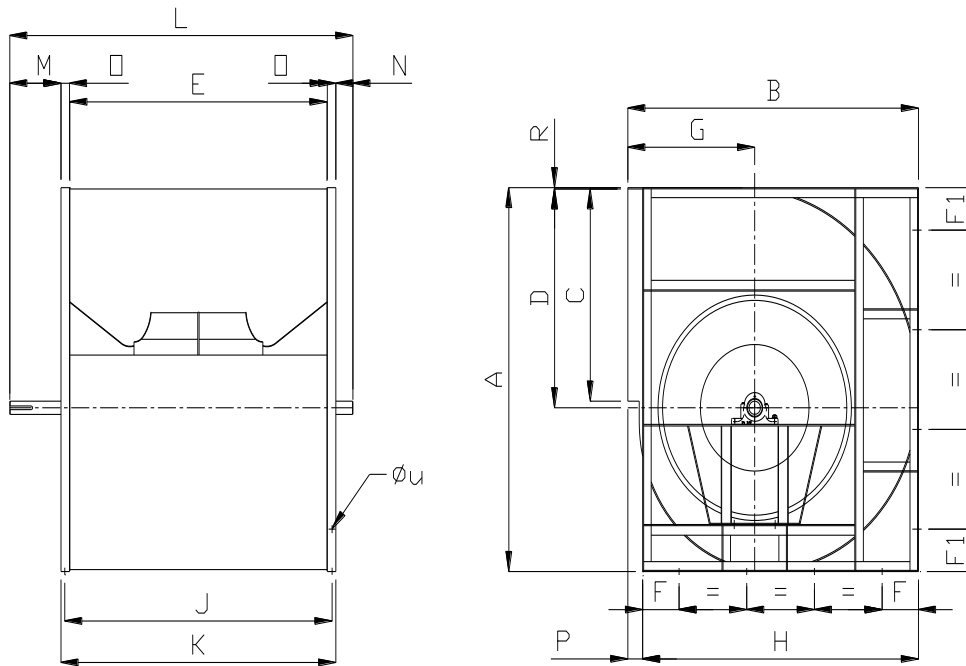

Model	A	B	C	D	E	F	F1	G	H	J	K	L	M	N	P	R	t	t1	W	Z	Φd	Φu
1120	2035	1822	1120	1170	1580	255	255	807	1727	1670	1736	2011	195	80	95	6	20	12	110	79.9	75	18
1250	2270	2025	1250	1305	1770	300	300	890	1932	1860	1926	2226	220	80	93	5	22	14	110	85	80	18
1400	2565	2313	1400	1470	1980	300	300	1040	2193	2070	2136	2468	230	102	120	9	22	14	110	85	80	18
1600	2895	2555	1600	1650	2260	320	320	1115	2425	2350	2416	2816	250	150	130	9	25	14	140	95	90	18
1800	3270	2935	1800	1860	2550	350	350	1300	2785	2656	2736	3171	300	135	150	10	25	14	180	95	90	18
2000	3625	3205	2000	2075	2850	350	350	1395	3055	2956	3036	3486	300	150	150	10	28	16	180	106	100	18

All dimensions in mm.



BCZ 315-400 'V'

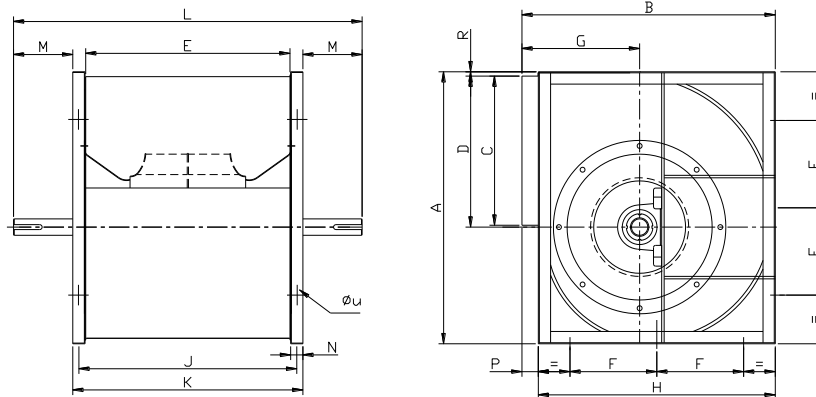

Model	A	B	C	D	E	F	G	H	J	K	L	M	N	P	R	t	t1	W	Z	Φd	Φu
315	582	557	315	334	378	140	265	522	405	432	672	120	30	35	8.5	10	8	50	38	35	14
355	662	620	355	378	500	425	288	580	533	563	853	145	30	40	11	12	8	70	43	40	14
400	743	690	400	423	560	235	320	650	593	623	913	145	30	40	10	12	8	70	43	40	14

BCZ 450 - 1000 'V'

All dimensions in mm.

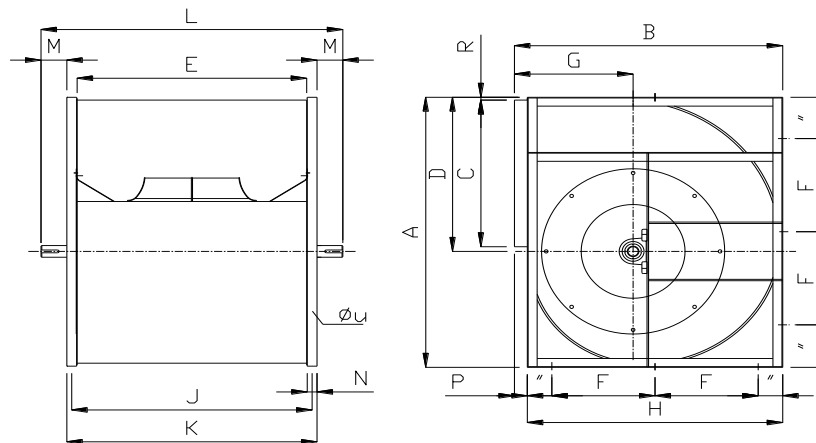

Model	A	B	C	D	E	F	G	H	J	K	L	M	N	P	R	t	t1	W	Z	Φd	Φu
450	832	760	450	475	640	266	345	715	673	703	1001	149	30	45	10	14	9	70	48.5	45	14
500	930	855	500	530	700	312.5	390	805	742	780	1128	174	38	50	14	14	9	90	53.5	50	14
560	1031	945	560	568	790	350	430	895	832	870	1192	162	38	50	8	16	10	90	59	55	14
630	1160	1040	630	662	890	400	460	990	932	970	1356	193	38	50	12	18	11	90	64	60	14
710	1300	1150	710	745	1000	470	502	1100	1054	1104	1496	196	50	50	12	18	11	110	69	65	18
800	1460	1300	800	835	1130	540	565	1240	1189	1234	1626	196	50	60	10	18	11	110	69	65	18
900	1643	1395	900	943	1270	615	635	1395	1327	1374	1804	215	50	60	13	20	12	110	74.5	70	18
1000	1815	1600	1000	1043	1400	690	695	1540	1459	1504	1984	240	50	60	13	22	14	110	85	80	18

All dimensions in mm.



BCZ 1120-2000 'V'

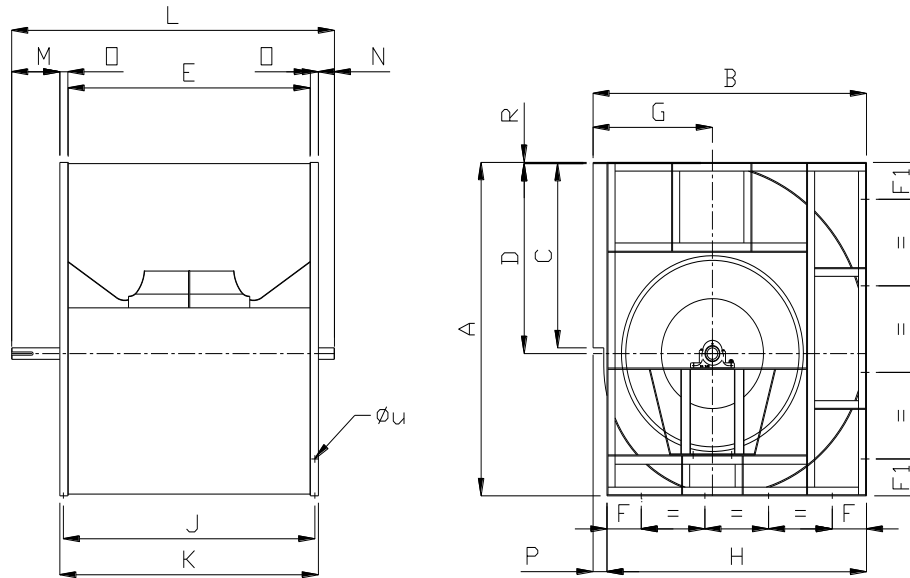

Model	A	B	C	D	E	F	F1	G	H	J	K	L	M	N	P	R	t	t1	W	Z	Φd	Φu
1120	2035	1822	1120	1170	1580	255	255	807	1727	1670	1736	2101	265	100	95	6	22	14	140	85	80	18
1250	2270	2025	1250	1305	1770	300	300	890	1932	1860	1926	2311	265	120	93	5	22	14	140	90	85	18
1400	2565	2313	1400	1470	1980	300	300	1040	2193	2061	2136	2521	265	120	120	9	25	14	140	95	90	18
1600	2895	2555	1600	1650	2260	320	320	1115	2425	2350	2416	2916	350	150	130	9	28	16	200	106	100	18
1800	3270	2935	1800	1860	2550	350	350	1300	2785	2656	2736	3231	360	135	150	10	28	16	250	106	100	18
2000	3625	3205	2000	2075	2850	350	350	1395	3055	2956	3036	3546	360	150	150	10	28	16	250	106	110	18

All dimensions in mm.

KEY WAY Dimensions.

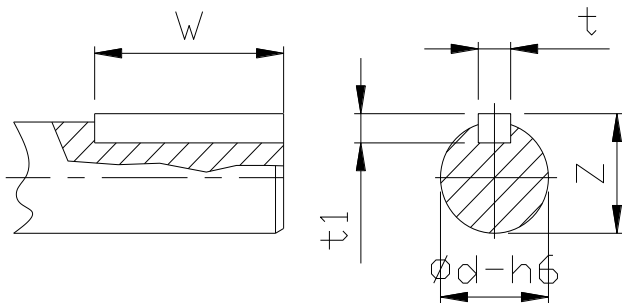



BCZ 355-1000 'G₂ H'

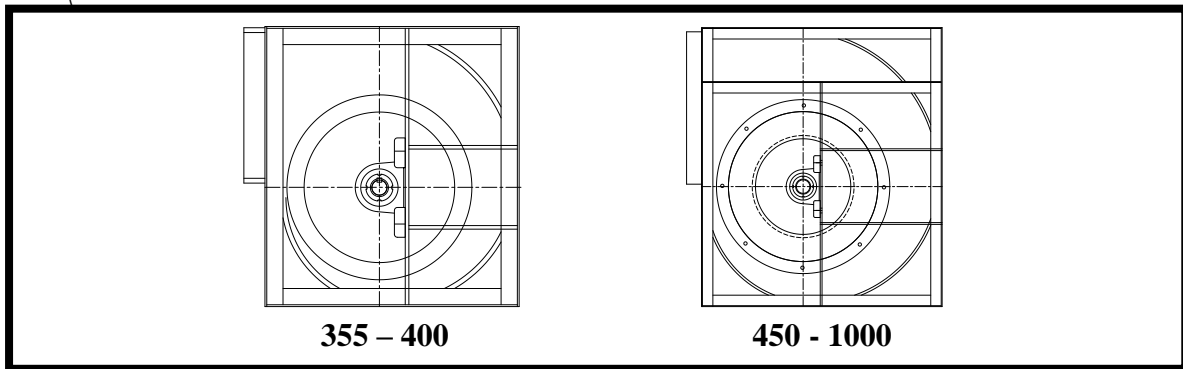
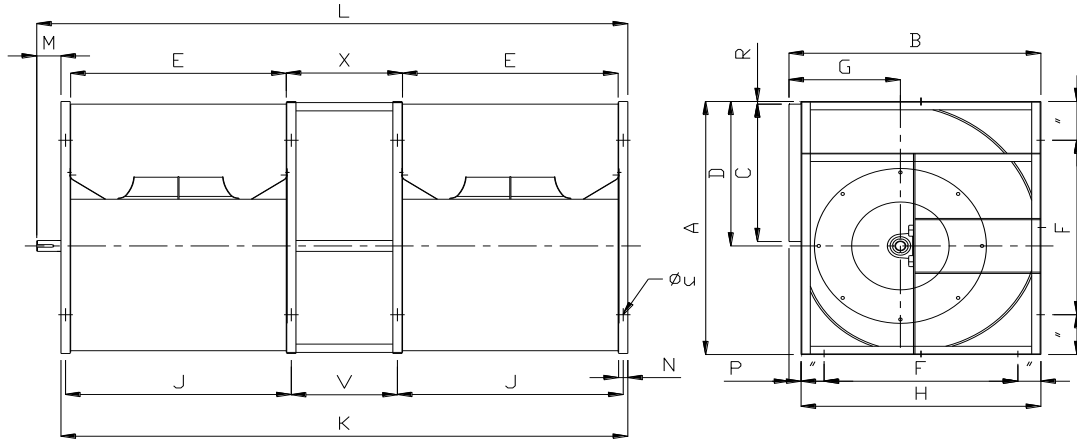

Model	A	B	C	D	E	F	G	H	J	K	L	M	N	P	R	V	X	t	t1	W	Z	Φd	Φu
355	662	620	355	378	500	425	288	580	541	1415	1525	110	30	40	11	385	355	12	8	70	43	40	14
400	743	690	400	423	560	470	320	650	593	1580	1715	135	30	40	10	430	400	14	9	90	48.5	45	14
450	832	760	450	475	640	532	345	715	682	1790	1925	135	30	45	10	485	450	14	9	90	53.5	50	14
500	930	855	500	530	700	625	390	805	742	1976	2111	135	38	50	14	538	500	16	10	90	59	55	14
560	1031	945	560	568	790	700	430	895	832	2216	2356	140	38	50	8	598	560	16	10	90	59	55	14
630	1160	1040	630	662	890	800	460	990	932	2486	2626	140	38	50	12	668	630	18	11	90	64	60	14
710	1300	1150	710	745	1000	940	502	1100	1054	2810	2960	150	50	50	12	760	710	18	11	90	64	60	18
800	1460	1300	800	835	1130	1080	565	1240	1189	3160	3310	150	50	60	10	850	800	18	11	90	64	60	18
900	1643	1395	900	943	1270	1230	635	1395	1327	3540	3690	150	50	60	13	950	900	18	11	90	64	60	18
1000	1815	1600	1000	1043	1400	1240	695	1540	1459	3900	4050	150	50	60	13	1050	1000	18	11	90	64	60	18

All dimensions in mm.



Accessories

■ Outlet Flange

Model	A	B	C	D	E	F	G
250	300	329	357	250	277	305	28
280	336	359	387	280	307	335	28
315	378	399	427	315	342	370	28
355	500	529	557	355	387	425	28
400	560	589	617	400	432	470	28
450	640	669	697	450	482	520	28
500	700	729	757	500	532	570	28
560	790	819	847	560	592	630	28
630	890	920	960	630	662	700	35
710	1000	1030	1070	710	742	780	35
800	1130	1160	1200	800	832	870	35
900	1270	1300	1340	900	932	970	35
1000	1400	1430	1470	1000	1032	1070	35

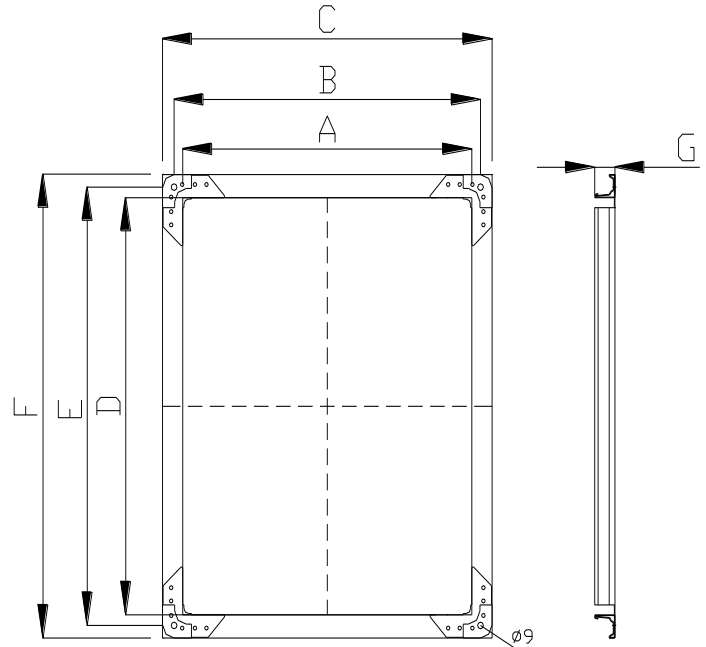

■ Pressure probes

On request, fan can be supplied fitted with “ Q-meter” pressure probes on the inlet cones which, with appropriate calibration, allow easy flow-rate measurement on the operating fan. Please Flowtech for further information.

The characteristics of the fan stated in this in this catalogue, like dimensions, performances and so on, can be modified without previous notice, therefore the company reserves the right to make changes to the illustrated products. Certified dimension will be provided upon request.



Centrifugal Fan Order Information

Fan Details			
● Fan Type		<input type="checkbox"/> DWDI <input type="checkbox"/> SWSI	
● Impeller Type		<input type="checkbox"/> Forward Curved <input type="checkbox"/> Backward Curved <input type="checkbox"/> Others : _____	
● Model & Size e.g. BCZ630-M		<input type="checkbox"/> Model : _____ (If known)	
● Drive type-Belt, Direct, Coupling(if differ from standard)		<input type="checkbox"/> Belt <input type="checkbox"/> Direct <input type="checkbox"/> Coupling <input type="checkbox"/> Others : _____ (Please state)	
● Drive Arrangements		<input type="checkbox"/> Bare fan <input type="checkbox"/> Complete with drive system	
● Rotation & Discharge e.g. CCW 90		<input type="checkbox"/> CW <input type="checkbox"/> CCW <input type="checkbox"/> 90 <input type="checkbox"/> 180 <input type="checkbox"/> 270 <input type="checkbox"/> 360	
● Motor Position (refer to Diagram) e.g. W		<input type="checkbox"/> W <input type="checkbox"/> X <input type="checkbox"/> Y <input type="checkbox"/> Z	
● Air Flow Rate		Q : _____ <input type="checkbox"/> L/S <input type="checkbox"/> m ³ /h <input type="checkbox"/> m ³ /min <input type="checkbox"/> m ³ /s <input type="checkbox"/> cfm	
● Pressure (static or total)		Sp : _____ TP : _____ <input type="checkbox"/> Pa <input type="checkbox"/> mmH ² o <input type="checkbox"/> inWG	
● Fan RPM (if specified)		Max : _____ Min : _____	
● Noise Level		<input type="checkbox"/> dB <input type="checkbox"/> dBA Lw : _____ Lp : _____ at distance : _____ m <input type="checkbox"/> Free Field <input type="checkbox"/> room condition <input type="checkbox"/> corner / wall	
● Ambient temperature		Temp : _____ °C	
● Air density, if differ from standard		<input type="checkbox"/> Density : _____ kg/m ³ <input type="checkbox"/> Altitude : _____ m	
Motor Detail		Fittings Detail	
● Power	<input type="checkbox"/> kW : _____ <input type="checkbox"/> HP : _____	● Accessories	<input type="checkbox"/> Inspection door <input type="checkbox"/> Drain plug <input type="checkbox"/> Flexible duct
● No. of Poles / Rpm	<input type="checkbox"/> 2P <input type="checkbox"/> 4P <input type="checkbox"/> 6P <input type="checkbox"/> Others : _____ (please state RPM)	Vibration Isolators:	<input type="checkbox"/> Rubber <input type="checkbox"/> Spring <input type="checkbox"/> Floor-mount <input type="checkbox"/> Ceiling-hang
● Voltage	<input type="checkbox"/> 220V <input type="checkbox"/> 415 <input type="checkbox"/> 380V <input type="checkbox"/> 440V <input type="checkbox"/> 400V <input type="checkbox"/> Others : _____	Silencers :	<input type="checkbox"/> With pod <input type="checkbox"/> Without pod <input type="checkbox"/> Inlet <input type="checkbox"/> Outlet <input type="checkbox"/> Both inlet & Outlet
● Phase	<input type="checkbox"/> 1 <input type="checkbox"/> 3	Counter-flanges :	<input type="checkbox"/> Flat L-type <input type="checkbox"/> U-type <input type="checkbox"/> Inlet <input type="checkbox"/> Outlet
● Frequency		Special Features	
● Frame size	<input type="checkbox"/> IEC: _____ <input type="checkbox"/> NEMA: _____ <input type="checkbox"/> Others : _____	● Other Requirements	<input type="checkbox"/> Painting <input type="checkbox"/> Powder coating <input type="checkbox"/> Hot-dipped galvanizing <input type="checkbox"/> Spark-resistant <input type="checkbox"/> Corrosion-resistant <input type="checkbox"/> Heat-resistant, temp. _____ °C <input type="checkbox"/> Smoke Spill, Max. temp. _____ °C for _____ Hr



THE FLOWTECH GROUP

● **TAIPEI Headquarters** 台北總公司

234 新北市永和區保生路一號 19 樓之 5

19F-5, No. 1, BaoSheng Rd., Yonghe dist, New Taipei City, Taiwan, 234

Tel : +886-2-2232-8066 Fax : +886-2-2231-0285~6

E-mail : ydc28066@ms8.hinet.net , flow.tech@msa.hinet.net

Website : www.flowtech.com.tw

● **Factory** 冬山廠

269 宜蘭縣冬山鄉得安村梅林路 658 號

No.658, Meilin Rd., De-an Village, Dongshan Township ,

Yilan County, Taiwan , 269

Tel : +886-39-612-449 Fax : +886-39-615-843

● **Lab** 實驗室

269 宜蘭縣冬山鄉內湖一路 102 號

No.102, Neihu 1st Rd., Dongshan Township,

Yilan County, Taiwan , 269

Tel : +886-39-612-449 Fax : +886-39-615-843

CNo. : CAT BCZ 0213.1 February 2013

AGENT (經銷商):

www.flowtech.com.tw