

Hurricane Louver

6" Deep · Fixed Drainable Blade · Severe Weather Louver

X6HW

STANDARD MATERIALS AND CONSTRUCTION

- HEAD:** .125" thick; extruded 6063-T5 aluminum
- SILL:** .125" thick; extruded 6063-T6 aluminum
- JAMBS:** .125" thick; extruded 6063-T5 aluminum
- BLADE:** .081" thick; extruded 6063-T5 aluminum
- ASSEMBLY:** Welded and mechanical fastened
- FINISH:** Mill
- SCREEN:** 1/2" removable expanded aluminum bird screen located on interior

MULLIONS: Exposed, vertical with 1 3/4" x .08" 6063-T5 extruded aluminum cover (multiple panels only); Hidden, horizontal

DESIGN DATA: NOA No: 05-1206.03 - TAS 100 with damper in sleeve
TAS 201, 202, 203 (180 PSF ≥ 36"W; 150 PSF < 36"W)

This system has been tested for water infiltration resistance and is a water resistant system when an AA20/AA21 damper is installed with the louver panel.

NOA No: 08-1030.05 - TAS 201, 202, 203 (150 PSF)

This system has not been tested for water infiltration resistance and is not a water resistant system.

OPTIONS

Finishes - Baked Enamel, Kynar, Anodize
Variety of bird and insect screens
See Available Option Chart for all other Options

NOTES

1. "A" width and "B" height are opening dimensions. Louvers are provided approximately 1/2" undersize.
2. NOA No: 05-1206.03: Panels over 60"W will have a 1 1/2" x 1 1/2" x .125" 6063-T5 support angle mounted vertically on interior at approximately midpoint full length of the louver.
3. NOA No: 08-1030.05: Panels over 30"W will have a 1 1/2" x 1 1/2" x .125" 6063-T5 support angle mounted vertically on interior at approximately midpoint full length of the louver.
4. Mullied panels may be horizontally installed to an unlimited number. Vertical stacking of mullied panels may occur providing a structural support is designed and installed by others to support all loads transferred from the louver assembly (single panel may run to unlimited height per elevation if no mullion exists).
5. Approved opening types: wood, steel, or concrete/masonry (masonry acceptable at jambs only, head and sill must be concrete). Anchoring details may vary.
6. Units are supplied with mounting angles, structural steel and mounting hardware for concrete installation as a standard. Please specify if louver are to be mounted in - substrate other than concrete.
7. See installation sketches for required mounting structure.

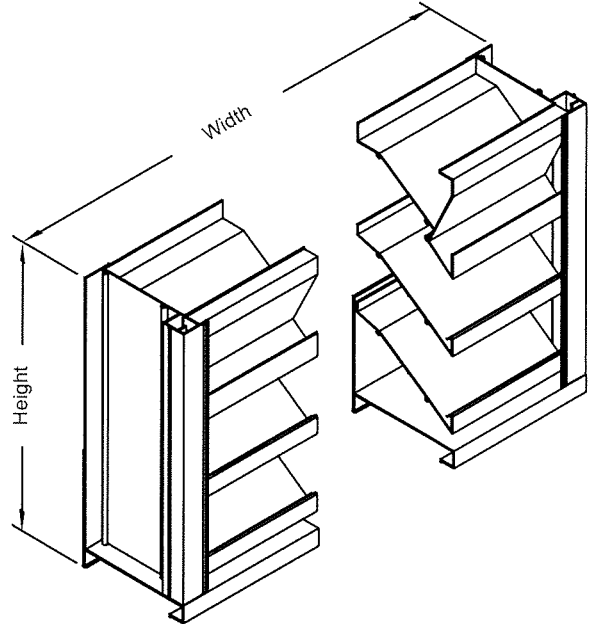

Available Options Chart

Option	NOA No: 05-1206.03		NOA No: 08-1030.05
	Screwed	Welded	w/Structural Steel
.125" Blades	No	Yes	STD*
Architectural Vertical Mullion	No	No	Yes
Welded Construction	No	STD*	STD*
Screwed Construction	Yes	No	No
Flanges 1 1/2"W x 1/8" thick	Yes	Yes	Yes
Extended Sill	Yes	Yes	Yes
Sill Pan	Yes	Yes	STD*†
Sleeve‡	Yes	Yes	No
Sleeve with Damper‡	Yes	Yes	No
Special Shape	No	Yes	No

*STD indicates this feature is standard construction for specified version and no other option is available.

†Sill Pan standard construction for Architectural Vertical Mullion. Optional construction for Visible Vertical Mullion.

‡See SI-SLVHRL-08.11 for more information.

LOUVER SIZES

Panels	Minimum Panel	Maximum Single Panel
NOA No: 05-1206.03	12"W x 12"H	96"W x 96"H
NOA No: 08-1030.05	12"W x 12"H	60"W x 96"H

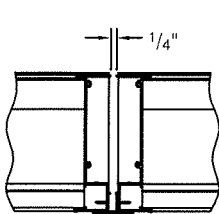

Standard Exposed Vertical Mullion (Available for NOA No: 05-1206.03)

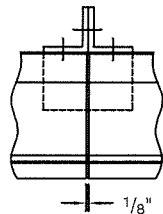

Optional Architectural Vertical Mullion (Available for NOA No: 08-1030.05)

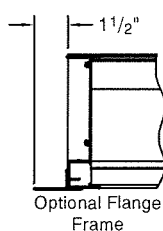

Optional Flange Frame

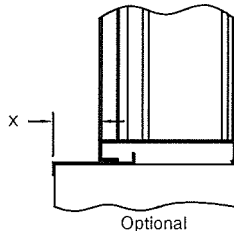

Optional Extended Sill

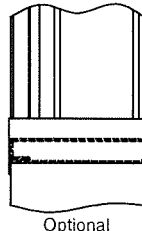

Optional Sill Pan

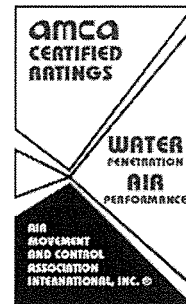

Cesco Products certifies that the model X6HW louver shown herein is licensed to bear the AMCA Seal. The ratings shown are based on tests and procedures performed in accordance with AMCA Publication 511 and comply with the requirements of AMCA Certified Ratings Program. The AMCA Certified Ratings Seal applies to Water Penetration and Air Performance Ratings only.

P.O. Box 606 • 7435 Industrial Rd. • Florence, KY 41042

Phone: 859-538-3450 • Fax: 859-647-7810

www.cescoproducts.com

SD-X6HW-08.12

Hurricane Louver

6" Deep · Fixed Drainable Blade · Severe Weather Louver

X6HW

Water Penetration: 0.01 oz. (3.0 g.) at 1250 fpm (6.35 m/s) maximum recommended free area velocity

Air Performance: 0.21 in.wg (52.1 Pa) at 1250 fpm (6.35 m/s) and 1150 SCFM (5.45 scm/s)

Free Area: 9.24 sq.ft. (0.858 sq.m) = 58% for 48"W x 48"H (1.22m x 1.22m) test size

1. Test size is 48"W x 48"H (1.2m x 1.2m).
2. Ratings do not include the effect of a screen.
3. Data is at standard air density (0.75 lbs/cu ft).
4. AMCA Ratings do not apply to special shapes.

Air Performance - Intake

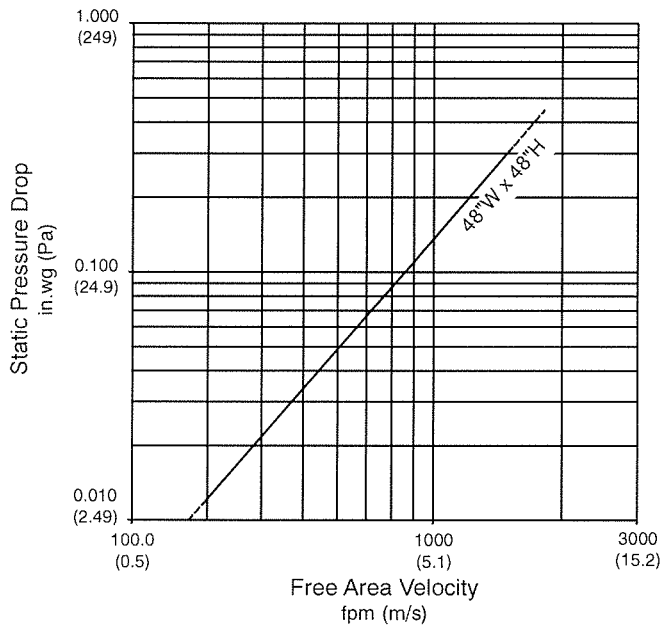

Water Penetration
 (15 min duration) Less than .01 oz./sq.ft.
 AMCA standards are based on a maximum of 1250 fpm free area velocity and a minimum of .01 oz./sq.ft. of free area water penetration. The AMCA test was unable to determine the beginning point of water penetration, since it lies above 1250 fpm free area velocity.

To determine minimum free area required for louver:

1. Divide the required flow by the maximum recommended free area velocity.
2. Select the most desirable louver size from the free area table that meets the minimum free area that is required.
3. Compare specified performance to the certified water penetration and air performance ratings.

Example:

Given 15,000 CFM design flow

$$1. \text{ minimum free area} = \frac{\text{design flow}}{\text{max recommended velocity}}$$

$$\text{minimum free area} = \frac{15,000}{1250} = 12.0 \text{ sq.ft.}$$

2. From the free area table, the required louver size is 48"W x 60"H.

Free Area in sq.ft. (sq.m)

		Nominal Width in Inches (mm)							
		12 (305)	24 (610)	36 (914)	48 (1219)	60 (1524)	72 (1829)	84 (2134)	96 (2438)
Nominal Height in Inches (mm)	12 (305)	0.18 (0.017)	0.43 (0.040)	0.69 (0.064)	0.94 (0.087)	1.16 (0.108)	1.42 (0.132)	1.67 (0.155)	1.93 (0.179)
	24 (610)	0.69 (0.064)	1.70 (0.158)	2.70 (0.251)	3.71 (0.345)	4.59 (0.426)	5.59 (0.519)	6.60 (0.613)	7.60 (0.706)
	36 (914)	1.21 (0.112)	2.96 (0.275)	4.72 (0.439)	6.47 (0.601)	8.01 (0.907)	9.76 (0.907)	11.52 (1.070)	13.27 (1.233)
	48 (1219)	1.72 (0.160)	4.23 (0.393)	6.73 (0.625)	9.24 (0.858)	11.43 (1.062)	13.93 (1.295)	16.44 (1.527)	18.94 (1.760)
	60 (1524)	2.24 (0.208)	5.49 (0.510)	8.75 (0.813)	12.00 (1.115)	14.85 (1.380)	18.11 (1.380)	21.36 (1.984)	24.62 (2.287)
	72 (1829)	2.75 (0.255)	6.76 (0.628)	10.76 (1.000)	14.77 (1.372)	18.27 (1.697)	22.28 (2.070)	26.28 (2.441)	30.29 (2.814)
	84 (2134)	3.27 (0.304)	8.02 (0.745)	12.78 (1.187)	17.53 (1.629)	21.69 (2.015)	26.45 (2.457)	31.20 (2.899)	35.96 (3.341)
	96 (2438)	3.78 (0.351)	9.29 (0.863)	14.79 (1.374)	20.30 (1.886)	25.12 (2.334)	30.62 (2.845)	36.13 (3.357)	41.63 (3.868)

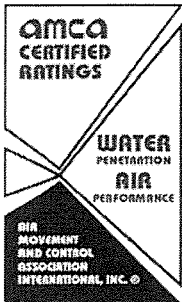

Cesco Products certifies that the model X6HW louver shown herein is licensed to bear the AMCA Seal. The ratings shown are based on tests and procedures performed in accordance with AMCA Publication 511 and comply with the requirements of AMCA Certified Ratings Program. The AMCA Certified Ratings Seal applies to Water Penetration and Air Performance Ratings only.

