

## Miami-Dade Approved Drainable Blade Louver

### Application and Design

ESD-635DE is a **Florida Product Approved and Miami-Dade Approved** stationary drainable blade extruded aluminum louver designed to protect air intake and exhaust openings in building exterior walls. ESD-635DE is tested in accordance with AMCA 500-L Air Performance and Water Penetration. ESD-635DE is tested in accordance with AMCA 540 Test Method for Louvers Impacted by Wind Borne Debris (Basic Protection, Missile Level D. When combined with the optional factory attached VCD-40 damper in the fully closed position, the ESD-635DE satisfies all requirements of the AMCA 550 High Velocity Wind Driven Rain Test. **ESD-635DE is licensed to bear the AMCA seal allowing design professionals to select and apply with confidence.** ESD-635DE is tested and approved per the following Florida test protocols: TAS 201 (Large Missile Impact), TAS 202 (Uniform Static Air Pressure) and TAS 203 (Cyclic Wind Loading). Building codes may allow ESD-635DE (when combined with the optional factory attached VCD-40 damper in the fully closed position) to be installed in locations where the space behind the louver is not designed to accept water penetration and houses non-water resistant/water proof equipment, components or supplies.

### Standard Construction

- Frame** . . . . . Heavy gauge extruded 6063T5 aluminum, 6 in. x 0.081 in. nominal wall thickness
- Blades** . . . . . Drainable design, heavy gauge extruded aluminum, 0.081 in. nominal wall thickness positioned at 37° angles on approximately 4 in. centers
- Construction** . . . . . Mechanically fastened
- Birdscreen** . . . . . 3/4 in. x 0.051 flattened expanded aluminum in removable frame, inside mount (rear), mill finish only
- Finish** . . . . . Mill
- Minimum Rough Opening Size** . . . . . 12 in. W x 12 in. H
- Maximum Rough Opening Size**
- Channel Frame** . . . . . 48.75 in. W x 48.50 in. H
- Maximum Rough Opening Size**
- Flange/Sleeve** . . . . . 48.50 in. W x 48.50 in. H

### Options (at additional cost)

- Factory attached VCD-40 control damper
- A variety of bird and insect screens
- Flange Frame (Channel Frame Installation)
- Mounting sleeve
- Blank off panel
- Filter rack
- Security bars
- A variety of architectural finishes including:
  - Clear anodize
  - Integral color anodize
  - Baked enamel
  - Kynar

Channel Frame Installation (default)

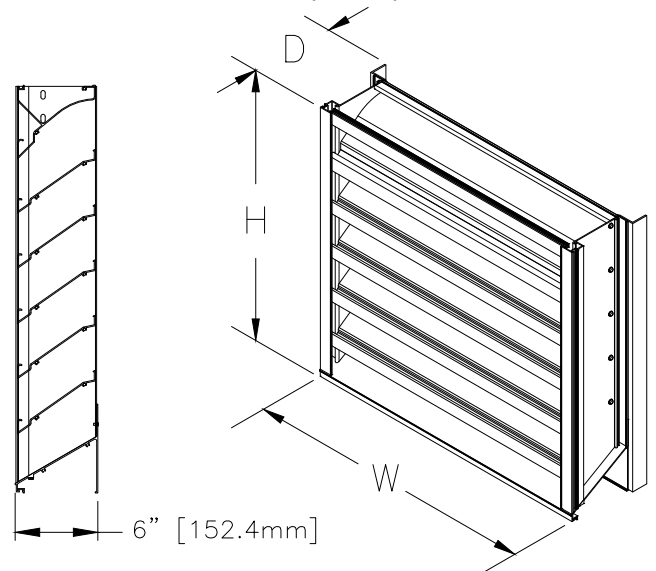

Flange/Sleeve Installation (optional)

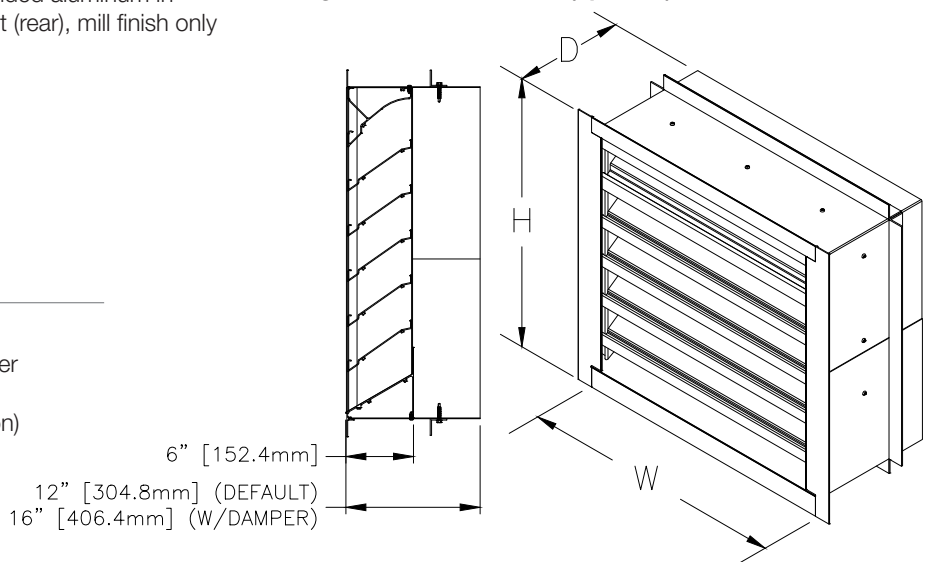

<sup>1</sup>Operable damper blades on optional VCD-40 damper in the closed position.

# PERFORMANCE DATA

# ESD-635DE

Florida Product Approval No: FL19675  
 Miami-Dade NOA No.: 19-0516.08, EXP. 2/4/2021  
 AMCA 540 and 550 Listed/  
 Maximum Wind-load: +/-150 PSF

## Free Area Chart

Louver Height Inches	Louver Width in Inches						
	12	18	24	30	36	42	48
12	0.19	0.32	0.44	0.57	0.69	0.82	0.94
18	0.48	0.80	1.11	1.42	1.74	2.05	2.36
24	0.77	1.27	1.77	2.27	2.77	3.27	3.76
30	1.05	1.73	2.41	3.09	3.77	4.45	5.13
36	1.35	2.22	3.09	3.97	4.84	5.71	6.59
42	1.62	2.67	3.71	4.76	5.81	6.86	7.91
<b>48</b>	<b>1.92</b>	<b>3.17</b>	<b>4.42</b>	<b>5.67</b>	<b>6.91</b>	<b>8.16</b>	<b>9.41</b>



Greenheck Fan Corporation certifies that the ESD-635DE louvers shown herein are licensed to bear the AMCA Seal. The ratings shown are based on tests and procedures performed in accordance with AMCA Publication 511 and comply with the requirements of the AMCA Certified Ratings Program. The AMCA Certified Ratings Seal applies to air performance and water penetration ratings.



**IMPACT RESISTANT LOUVER**  
*Basic Protection Level D*

See [www.AMCA.org](http://www.AMCA.org) for all certified or listed products

This label does not signify AMCA airflow performance certification.



**HIGH VELOCITY RAIN RESISTANT WITH BLADES FULLY CLOSED AND IMPACT RESISTANT LOUVER**  
*Basic Protection Level D*

See [www.AMCA.org](http://www.AMCA.org) for all certified or listed products

This label does not signify AMCA airflow performance certification.

With factory attached VCD-40 damper in the fully closed position.

## Airflow Resistance (Standard Air - .075 lb/ft<sup>3</sup>)

The graph plots Static Pressure Drop (Pa and in. wg) on the y-axis against Free Air Velocity (ft/min and m/s) on the x-axis. Two lines represent Intake and Exhaust resistance. A text box specifies: Test Size 48 in. x 48 in., Standard Air - .075 lb/ft<sup>3</sup>.

Model ESD-635DE resistance to airflow (pressure drop) varies depending on louver application (air intake or air exhaust). Free area velocities (shown) are higher than average velocity through the overall louver size. See louver selection information. (Test Figure 5.5-6.5)

## Water Penetration (Standard Air - .075 lb./ft.3)

Test size 48 in. x 48 in. Test duration of 15 min.

The graph plots Water Penetration per Unit Free Area (ml/m2 and oz/ft2) on the y-axis against Free Area Velocity (ft/min and m/s) on the x-axis. A single data point is marked with an asterisk at approximately 1250 ft/min. A text box specifies: Test Size 48 in. x 48 in., Test Period 15 minutes, Standard Air - .075 lb/ft<sup>3</sup>.

The AMCA Water Penetration Test provides a method for comparing various louver models and designs as to their efficiency in resisting the penetration of rainfall under specific laboratory test conditions. The beginning point of water penetration is defined as that velocity where the water penetration curve projects through .01 oz. of water (penetration) per sq. ft. of louver free area. **\*The beginning point of water penetration for Model ESD-635DE is above 1250 fpm free area velocity.** These performance ratings do not guarantee a louver to be weatherproof or stormproof and should be used in combination with other factors including good engineering judgement in selecting louvers.

Note: AMCA licensed performance data shown herein pertains only to the louver and does not include effects of the factory attached VCD-40 damper. AMCA 550 Listing shown herein pertains only to the ESD-635DE louver with factory attached VCD-40 damper in the closed position.

# OPTION DRAWINGS

# ESD-635DE

Florida Product Approval No: FL19675  
 Miami-Dade NOA No.: 19-0516.08, EXP. 2/4/2021  
 AMCA 540 and 550 Listed  
 Maximum Wind-load: +/-150 PSF

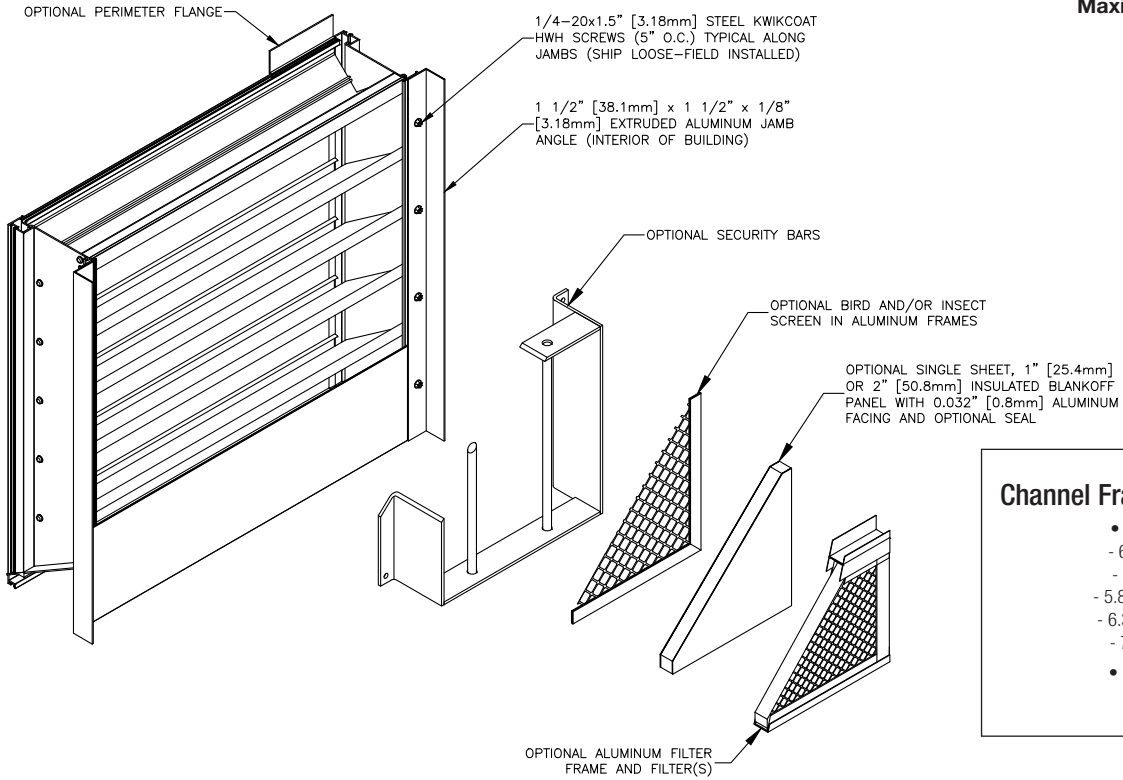

**Channel Frame Installation (default)**

- **Min. Structure Depth**
  - 6.8 in. (wood substrate)
  - 5.9 in. (steel substrate)
  - 5.8 in. (aluminum substrate)
  - 6.3 in. (concrete substrate)
  - 7.3 in. (CMU substrate)
- **Max. Structure Depth**
  - unlimited

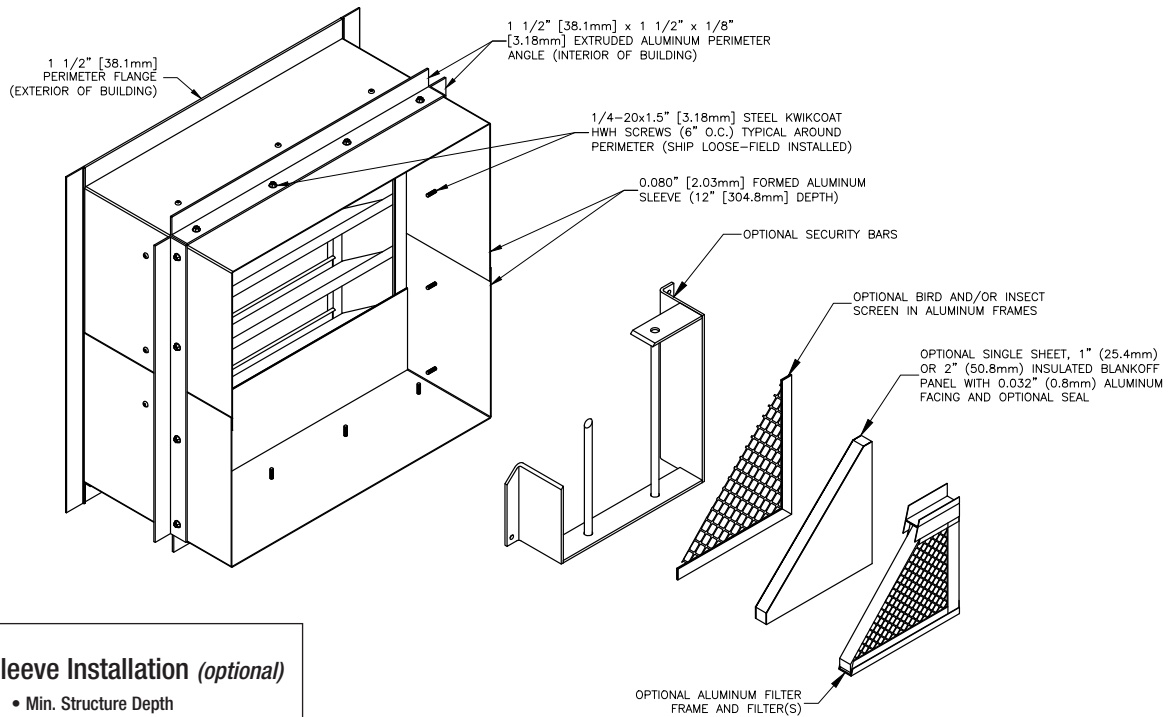

**Flange/Sleeve Installation (optional)**

- **Min. Structure Depth**
  - 6.0 in.
- **Max. Structure Depth**
  - 10.5 in. (12 in. sleeve)
  - 14.5 in. (16 in. sleeve)

# OPTION DRAWINGS

# ESD-635DE with VCD-40

Florida Product Approval No: FL19675  
 Miami-Dade NOA No.: 19-0516.08, EXP. 2/4/2021  
 AMCA 540 and 550 Listed  
 Maximum Wind-load: +/-150 PSF

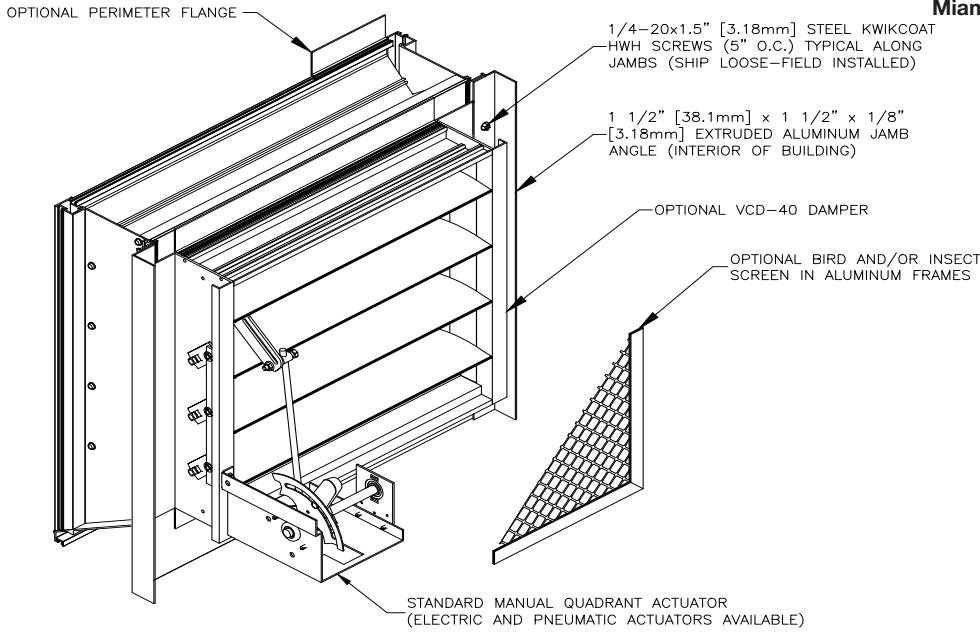

**Channel Frame Installation (default)**

- **Min. Structure Depth**
  - 6.8 in. (wood substrate)
  - 5.9 in (steel substrate)
  - 5.8 in. (aluminum substrate)
  - 6.3 in. (concrete substrate)
  - 7.3 in. (CMU substrate)
- **Max. Structure Depth**
  - unlimited

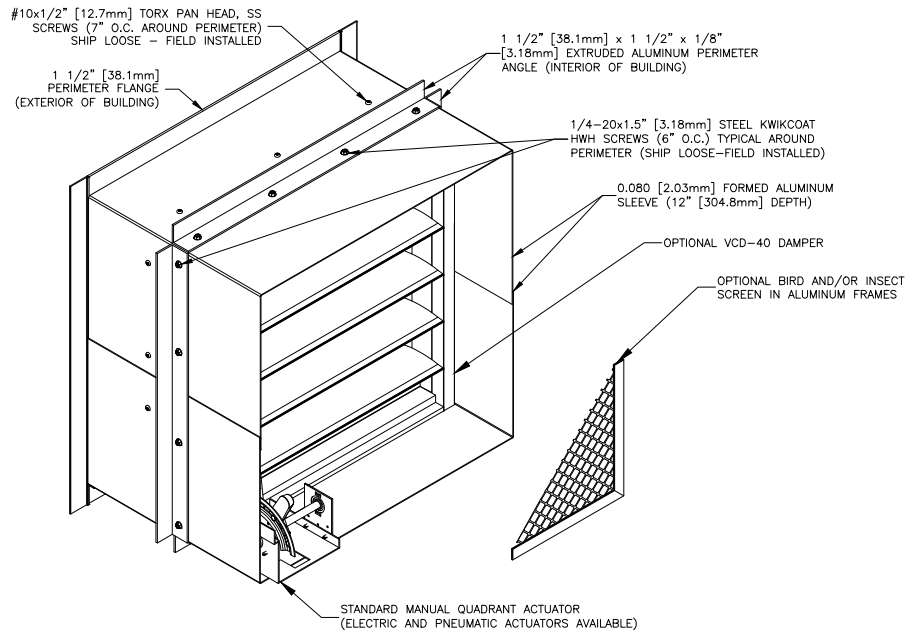

**Flange/Sleeve Installation (optional)**

- **Min. Structure Depth**
  - 6.0 in.
- **Max. Structure Depth**
  - 10.5 in. (12 in. sleeve)
  - 14.5 in. (16 in. sleeve)

## Building Condition/Substrate Limitations

### Channel Installation

- All steel substrate should be min. 16 Ga. FY= 33 KSI
- All concrete substrate shall be min. 2000 PSI
- All concrete masonry shall be ASTM C90, Type II, grout-filled
- All wood substrate shall be G= 0.42 density or better
- All aluminum substrate shall be min 0.125 in. thick FY=16 KSI

### Flange/Sleeve Installation

- Any substrate acceptable that is capable of withstanding imposed loads.

*For additional information reference the Installation, Operation and Maintenance (IOM) manuals.*



ESD-635DE  
 July 2020

Copyright © 2020 Greenheck Fan Corporation

Greenheck Fan Corporation reserves the right to make product changes without notice.