

Application

The EFD-637-MD is engineered and tested to withstand extreme loads, debris impact and cyclic fatigue failure associated with the severe weather effects of hurricanes (Miami-Dade County approval #18-1211.07). Constructed from 6063-T5 extruded aluminum the EFD-637-MD's design accommodates installations of unlimited width or height and single section assemblies up to 48" x 144" (1219 x 3658). Specially designed water resistant seam covers further enhance performance and aesthetics of this industry leading product.

Standard Construction

Material: Mill finish 6063-T5 extruded aluminum.

Frame: 6" deep x 0.125" thick (152 x 3) channel.

Blades: 37¹/₂° x 0.081" (2) thick horizontal style.

Screen: 1/2" x 0.063" (12.7 x 1.6) expanded and flattened aluminum.

Mullion: Visible.

Minimum Size: 12" x 12" (305 x 305)

Maximum Size: Single section: 48" x 144" (1219 x 3658)
Multiple section: Unlimited width x 144" (3658)
or 48" (1219) x unlimited height

Installation Hardware: Standard clip angles and associated fasteners (anchors to substrate by others - refer to installation instructions)

Options

- Factory finish:
 - High Performance Fluoropolymer - 100% resin Newlar®/ 70% resin Kynar®
 - Baked Enamel
 - Clear or Color Anodized, Class 1
 - Prime Coat
- 1¹/₂" (38) flange frame.
- Alternate bird or insect screens.
- Insulated or non-insulated blank-off panels.
- Filter racks.
- Head and/or sill flashing.
- Full sleeve and retaining angles (eliminates need for anchors to substrate; 1-1/2" flange frame required; available for single-section only).

Ratings

Free Area: [48" x 48" (1219 x 1219) unit]: 8.7 ft² (0.81 m²)
54.6%

Performance @ Beginning Point of Water Penetration

Free Area Velocity: 1100 fpm (5.59 m/s)

Air Volume Delivered: 9600 cfm (4.53 m³/s)

Pressure Loss: 0.14 in.wg. (35 Pa)

Velocity @ 0.15 in.wg. Pressure Loss: 1139 fpm (5.78 m/s)

Miami Dade County: NOA No. 18-1211.07 (Expires 2/19/2024)
Approved to FBC TAS202-94, TAS201-94
and TAS203-94.

Florida Building Code Approval: No. FL12672

Design Load: 150 psf

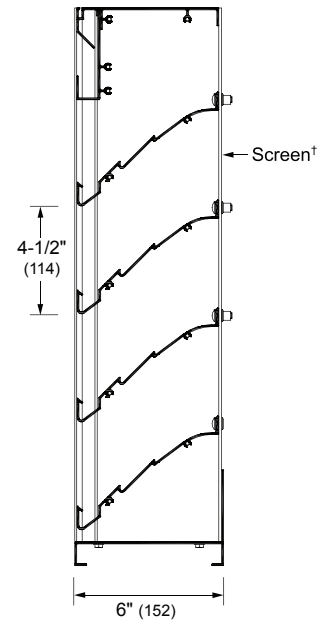
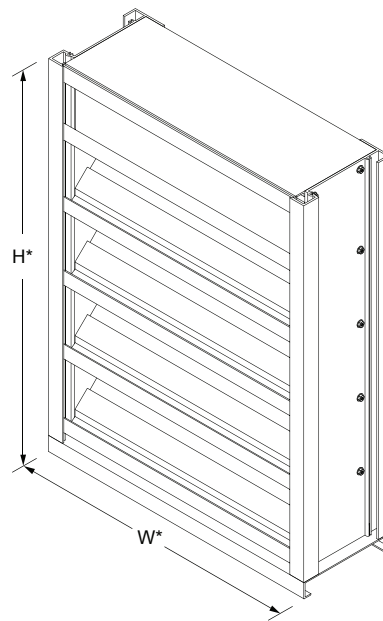

Model EFD-637-MD
(standard)
*Louvers dimensions furnished
approximately 1/2" (13) undersize.

Vertical Section
†Screen adds approximately
3/16" (5) to louver depth.

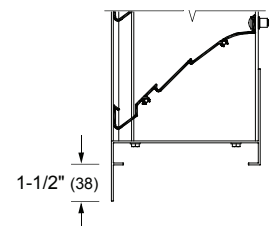

Flange Frame
(optional)

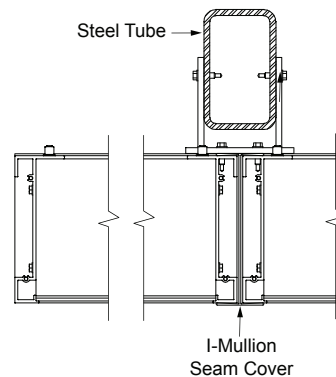

Visible Vertical Mullion
(standard)

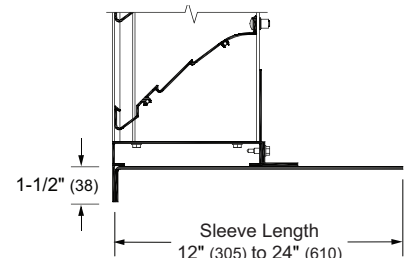

Sleeve
(optional, single sections only)



Certified Ratings:

All-Lite certifies that the model EFD-637-MD shown herein is licensed to bear the AMCA seal. The ratings shown are based on tests and procedures performed in accordance with AMCA Publication 511 and comply with the requirements of the AMCA Certified Ratings Program. The AMCA Certified Ratings seal applies to air performance and water penetration ratings.

Information is subject to change without notice or obligation.

NOTE: Dimensions in parentheses () are millimeters.

Performance Data

Free Area (ft²)

		Width (Inches)						
		12	18	24	30	36	42	48
Height (Inches)	12	0.2	0.4	0.6	0.7	0.9	1.1	1.2
	18	0.5	0.8	1.2	1.5	1.9	2.3	2.6
	24	0.7	1.2	1.7	2.2	2.7	3.2	3.7
	30	0.9	1.6	2.3	2.9	3.6	4.3	5.0
	36	1.1	2.0	2.9	3.7	4.6	5.5	6.4
	42	1.3	2.4	3.4	4.4	5.4	6.4	7.5
	48	1.6	2.8	3.9	5.1	6.3	7.5	8.7
	54	1.8	3.2	4.6	6.0	7.3	8.7	10.1
	60	2.0	3.5	5.1	6.6	8.1	9.7	11.2
	66	2.2	3.9	5.6	7.3	9.0	10.7	12.4
	72	2.5	4.4	6.3	8.2	10.0	11.9	13.8
	78	2.7	4.7	6.8	8.8	10.8	12.9	14.9
	84	2.9	5.1	7.3	9.5	11.7	14.0	16.2
	90	3.2	5.6	8.0	10.4	12.8	15.2	17.6
	96	3.3	5.9	8.5	11.0	13.6	16.1	18.7
	102	3.6	6.3	9.0	11.7	14.5	17.2	19.9
108	3.8	6.7	9.6	12.6	15.5	18.4	21.3	
114	4.0	7.1	10.1	13.2	16.3	19.3	22.4	
120	4.2	7.5	10.7	13.9	17.2	20.4	23.6	
126	4.5	7.9	11.3	14.8	18.2	21.6	25.0	
132	4.7	8.3	11.8	15.4	19.0	22.5	26.1	
138	4.9	8.7	12.4	16.1	19.9	23.6	27.4	
144	5.2	9.1	13.0	17.0	20.9	24.8	28.8	



Certified Ratings:
All-Lite certifies that the model EFD-637-MD shown herein is licensed to bear the AMCA seal. The ratings shown are based on tests and procedures performed in accordance with AMCA Publication 511 and comply with the requirements of the AMCA Certified Ratings Program. The AMCA Certified Ratings seal applies to air performance, and water penetration ratings.

Pressure Loss

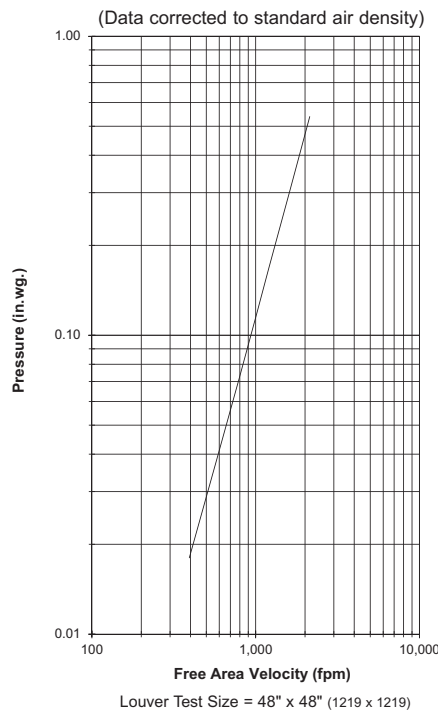

Pressure loss tested in accordance with Figure 5.5 of AMCA Standard 500-L.

Water Penetration

AMCA defines the beginning point of water penetration as the free area velocity at the intersection of a simple linear regression of test data and the line of 0.01 ounces of water per square foot of free area measured through a 48" x 48" louver during a 15 minute period. The AMCA water penetration test provides a method for comparing louver models and designs as to their efficiency in resisting the penetration of rainfall under specific lab conditions. All-Lite recommends that intake louvers are selected with a reasonable margin of safety below the beginning point of water penetration in order to avoid unwanted penetration during severe storm conditions.

Selection Criteria

Follow the steps listed below to calculate the louver size needed to satisfy the required air volume while minimizing the adverse effects of water penetration and pressure loss.

- Determine the Free Area Velocity (FAV) at the maximum allowable pressure loss using the *Pressure Loss* chart to the left. While job conditions vary, typically, the maximum allowable pressure loss should not exceed 0.15 in.wg., and the FAV for 0.15 in.wg. pressure loss is listed on the front page of this sheet.
- Intake Applications** If the FAV at the Beginning Point of Water Penetration (shown below) is less than the FAV from step 1, then use the FAV at the Beginning Point of Water Penetration in step 3, otherwise use the FAV from step 1.
- Exhaust Applications** Use the FAV from step 1 in step 3.
- Calculate the total louver square footage required using the following equation.

$$\frac{\text{Required Air Volume (cfm)}}{\text{FAV (fpm)}} = \frac{\text{Required Louver (Free-Area) Size (ft}^2\text{)}}{\text{ft}^2}$$

- Using the *Free Area* chart above, select a louver width and height that yields a free area ft² greater than or equal to the required louver size calculated in step 3.

Water Penetration

Beginning Point of Water Penetration = 1100 fpm

