

L6375D STATIONARY LOUVER ROLL FORMED STEEL

STANDARD CONSTRUCTION

FRAME

6" (152) deep, 18 gage (1.3) galvanized steel.

BLADES

18 (1.3) gage galvanized steel. Drainable blades are positioned at 37 1/2° angle and spaced approximately 4 3/4" (121) center to center.

SCREEN

1/2" mesh x 19 gage (13 x 1.1) galvanized bird screen in removable frame. Screen adds approximately 1/2" (13) to louver depth.

FINISH

Mill.

MINIMUM SIZE

12"w x 12"h (305 x 305).

APPROXIMATE SHIPPING WEIGHT

5 lbs. per sq. ft (24.4 kg/m²)

MAXIMUM FACTORY ASSEMBLY SIZE

64 square feet (6m²) per section, not to exceed 60"w x 120"h (1524 x 3048) or 120"w x 60"h (3048 x 1524).

Louvers larger than the maximum factory assembly size will require field assembly of smaller sections.

SUPPORTS

Louvers may be provided with rear mounted blade supports that increase overall louver depth depending on louver size, assembly configuration or windload.

Consult Ruskin for additional information.

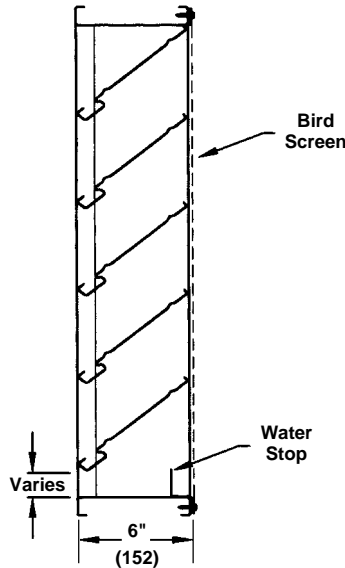
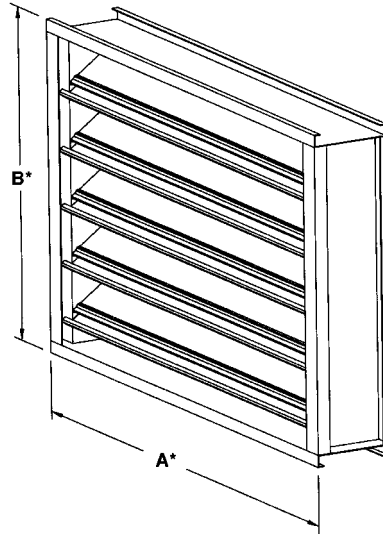

FEATURES

The L6375D offers:

- 54% Free Area.
- Published performance ratings based on testing in accordance with AMCA Publication 511.
- Drain gutters in each blade and downspouts in jambs and mullions to drain water from louver for minimum water cascade from blade to blade.
- Low pressure drop and low water penetration.
- Hidden vertical blade supports allow continuous blade appearance up to 120"w (3048).
- Economical galvanized steel construction.

VARIATIONS

Variations to the basic design of this louver are available at additional cost. They include:

- Extended sill.
- Hinged frame.
- Front or rear security bars.
- Filter racks.
- Installation angles.
- A variety of bird and insect screens.
- Heavier, 16 gage (1.6) construction.
- Formed stainless steel construction with 18 gage (1.3) or 16 gage (1.6) frame and blades.
- Selection of finishes: prime coat, baked enamel (modified fluoropolymer), epoxy, Acrodize and Kynar.

Consult Ruskin for other special requirements.

FRAME CONSTRUCTION

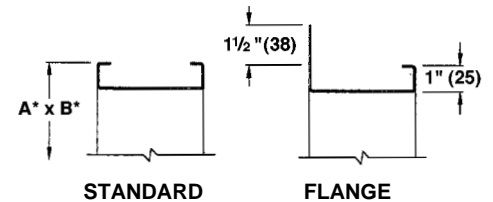

Dimensions in parenthesis () indicate millimeters.

*Units furnished 1/4" (6) smaller than given opening dimensions.

TAG	QTY.	SIZE		FRAME	VARIATIONS
		A*-WIDE	B*-HIGH		
PROJECT ARCH./ENGR. REPRESENTATIVE			LOCATION CONTRACTOR DATE		

SUGGESTED SPECIFICATION

Furnish and install louvers as hereinafter specified where shown on plans or as described in schedules. Louvers shall be stationary drainable type entirely contained within a 6" (152) frame. Louvers shall include a drain gutter in each blade and downspouts in jambs and mullions. Louver components (heads, jambs, sills, blades, and mullions) shall be factory assembled by the louver manufacturer. Louver sizes too large for shipping shall be built up by the contractor from factory assembled louver sections to provide overall sizes required. Louver design shall incorporate structural supports required to withstand a wind load of 20 lbs. per sq. ft. (.96kPa) (equivalent of a 90 mph wind [145 KPH] - specifier may substitute any loading required).

Louvers shall be Ruskin Model L6375D construction as follows:

- Frame: 18 gage (1.3) galvanized steel.
- Blades: 18 gage (1.3) galvanized steel positioned at 37¹/₂° angle and spaced approximately 4³/₄" (121) center to center.
- Screen: 1/2" mesh x 19 gage (13 x 1.1) galvanized steel in removable frame.
- Finish: Select finish specification from Ruskin/Valspar Finishes Brochure.

Published louver performance data bearing the AMCA Certified Ratings Seal for Air Performance & Water Penetration must be submitted for approval prior to fabrication and must demonstrate pressure drop and water penetration equal to or less than the Ruskin model specified.

PERFORMANCE DATA

AMCA Standard 500 provides a reasonable basis for testing and rating louvers. Testing to AMCA 500 is performed under a certain set of laboratory conditions. This does not guarantee that other conditions will not occur in the actual environment where louvers must operate.

Designs should provide a reasonable safety factor for louver performance by selecting at some point below pressure drop or water penetration system requirements.

WATER PENETRATION

Test size 48" wide x 48" high (1219 x 1219)

Beginning point of water penetration at .01 oz./sq. ft. is 896 fpm (273 m/min).

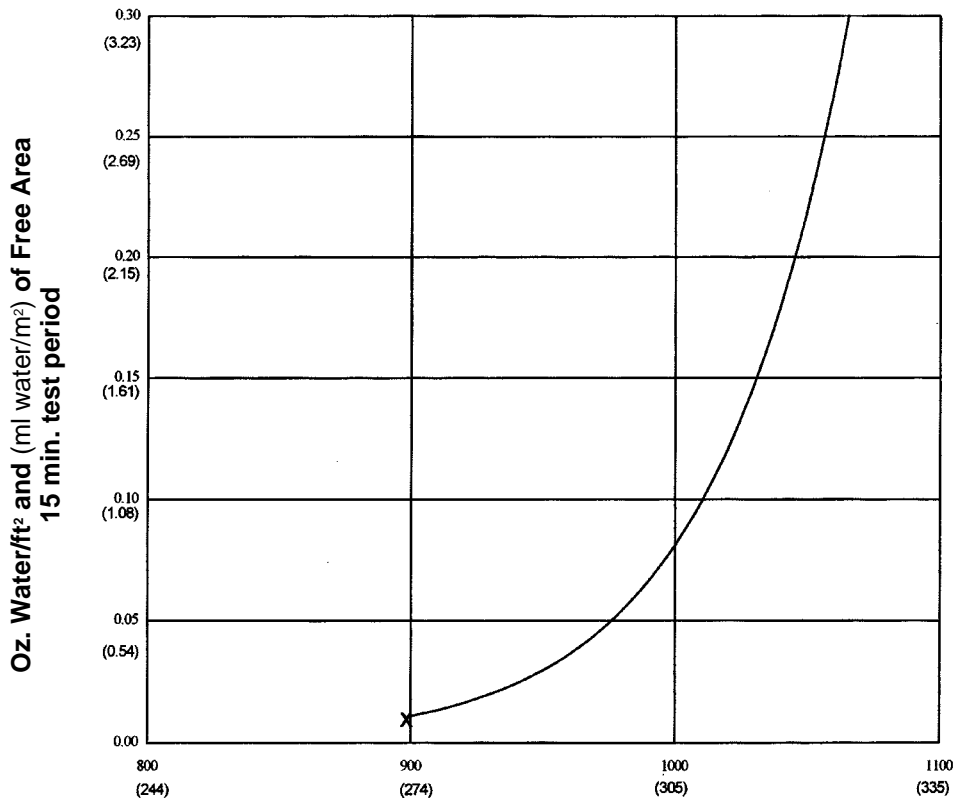

Ruskin Company certifies that the Louvers shown herein are licensed to bear the AMCA Seal. The ratings shown are based on tests and procedures performed in accordance with AMCA Publication 511 and comply with the requirements of the AMCA Certified Ratings Program. The AMCA Certified Ratings Seal applies to air performance and water penetration ratings only.

Free Area Velocity in feet and (meters) per minute
Standard air .075 lb/ft³ (1.2 kg/m³)

FREE AREA GUIDE

Free Area Guide shows free area in ft² and m² for various sizes of L6375D.

Height – Inches and Meters	12	18	24	30	36	42	48	54	60	66	72	78	84	90	96	102	108	114	120
	0.30	0.46	0.61	0.76	0.91	1.07	1.22	1.37	1.52	1.68	1.83	1.98	2.13	2.29	2.44	2.59	2.74	2.90	3.05
12	0.21	0.34	0.48	0.61	0.75	0.88	1.01	1.15	1.28	1.41	1.55	1.68	1.81	1.95	2.08	2.21	2.35	2.48	2.61
0.30	0.02	0.03	0.04	0.06	0.07	0.08	0.09	0.11	0.12	0.13	0.14	0.16	0.17	0.18	0.19	0.21	0.22	0.23	0.24
18	0.50	0.81	1.12	1.43	1.75	2.06	2.37	2.69	3.00	3.31	3.62	3.94	4.25	4.56	4.87	5.19	5.50	5.81	6.13
0.46	0.05	0.08	0.10	0.13	0.16	0.19	0.22	0.25	0.28	0.31	0.34	0.37	0.40	0.42	0.45	0.48	0.51	0.54	0.57
24	0.78	1.27	1.76	2.26	2.75	3.24	3.73	4.22	4.72	5.21	5.70	6.19	6.69	7.18	7.67	8.16	8.65	9.15	9.64
0.61	0.07	0.12	0.16	0.21	0.26	0.30	0.35	0.39	0.44	0.48	0.53	0.58	0.62	0.67	0.71	0.76	0.80	0.85	0.90
30	1.06	1.73	2.41	3.08	3.75	4.42	5.09	5.76	6.44	7.11	7.78	8.45	9.12	9.79	10.47	11.14	11.81	12.48	13.15
0.76	0.10	0.16	0.22	0.29	0.35	0.41	0.47	0.54	0.60	0.66	0.72	0.79	0.85	0.91	0.97	1.04	1.10	1.16	1.22
36	1.35	2.20	3.05	3.90	4.75	5.60	6.45	7.30	8.16	9.01	9.86	10.71	11.56	12.41	13.26	14.11	14.96	15.81	16.66
0.91	0.13	0.20	0.28	0.36	0.44	0.52	0.60	0.68	0.76	0.84	0.92	1.00	1.07	1.15	1.23	1.31	1.39	1.47	1.55
42	1.52	2.48	3.44	4.40	5.36	6.32	7.28	8.24	9.20	10.16	11.12	12.08	13.04	14.00	14.96	15.92	16.87	17.83	18.79
1.07	0.06	0.10	0.14	0.17	0.21	0.25	0.29	0.32	0.36	0.40	0.44	0.48	0.51	0.55	0.59	0.63	0.66	0.70	0.74
48	1.80	2.94	4.08	5.22	6.36	7.50	8.64	9.78	10.92	12.06	13.19	14.33	15.47	16.61	17.75	18.89	20.03	21.17	22.31
1.22	0.17	0.27	0.38	0.49	0.59	0.70	0.80	0.91	1.02	1.12	1.23	1.33	1.44	1.54	1.65	1.76	1.86	1.97	2.07
54	2.09	3.41	4.72	6.04	7.36	8.68	10.00	11.32	12.64	13.95	15.27	16.59	17.91	19.23	20.55	21.86	23.18	24.50	25.82
1.37	0.19	0.32	0.44	0.56	0.68	0.81	0.93	1.05	1.18	1.30	1.42	1.54	1.67	1.79	1.91	2.03	2.16	2.28	2.40
60	2.37	3.87	5.37	6.87	8.36	9.86	11.36	12.86	14.35	15.85	17.35	18.85	20.35	21.84	23.34	24.84	26.34	27.83	29.33
1.52	0.22	0.36	0.50	0.64	0.78	0.92	1.06	1.20	1.33	1.47	1.61	1.75	1.89	2.03	2.17	2.31	2.45	2.59	2.73
66	2.54	4.15	5.76	7.36	8.97	10.58	12.18	13.79	15.40	17.00	18.61	20.22	21.82	23.43	25.04	26.64	28.25	29.86	31.46
1.68	0.24	0.39	0.54	0.68	0.83	0.98	1.13	1.28	1.43	1.58	1.73	1.88	2.03	2.18	2.33	2.48	2.63	2.78	2.93
72	2.83	4.61	6.40	8.19	9.97	11.76	13.54	15.33	17.12	18.90	20.69	22.47	24.26	26.05	27.83	29.62	31.40	33.19	34.98
1.83	0.26	0.43	0.60	0.76	0.93	1.09	1.26	1.43	1.59	1.76	1.92	2.09	2.26	2.42	2.59	2.75	2.92	3.09	3.25
78	3.11	5.08	7.04	9.01	10.97	12.94	14.90	16.87	18.83	20.80	22.77	24.73	26.70	28.66	30.63	32.59	34.56	36.52	38.49
1.98	0.29	0.47	0.65	0.84	1.02	1.20	1.39	1.57	1.75	1.93	2.12	2.30	2.48	2.67	2.85	3.03	3.21	3.40	3.58
84	3.40	5.54	7.69	9.83	11.97	14.12	16.26	18.41	20.55	22.70	24.84	26.99	29.13	31.28	33.42	35.57	37.71	39.86	42.00
2.13	0.32	0.52	0.71	0.91	1.11	1.31	1.51	1.71	1.91	2.11	2.31	2.51	2.71	2.91	3.11	3.31	3.51	3.71	3.91
90	3.57	5.82	8.07	10.33	12.58	14.84	17.09	19.34	21.60	23.85	26.10	28.36	30.61	33.00	35.26	37.51	39.76	42.02	44.27
2.29	0.33	0.54	0.75	0.96	1.17	1.38	1.59	1.80	2.01	2.22	2.43	2.64	2.85	3.07	3.28	3.49	3.70	3.91	4.12

Width – Inches and Meters

PRESSURE DROP

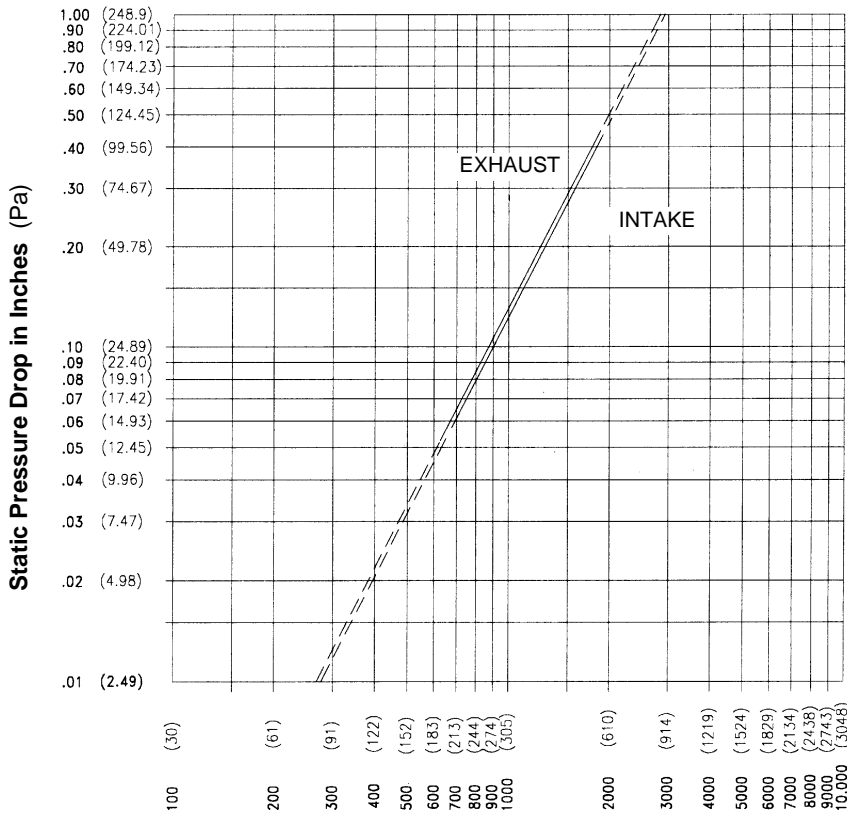

Ratings do not include the effect of a bird screen.

Air Velocity in feet (meters) per minute through Free Area

TYPICAL INSTALLATION DETAILS

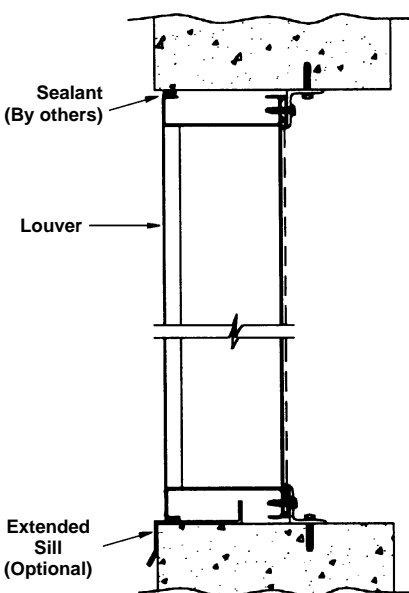
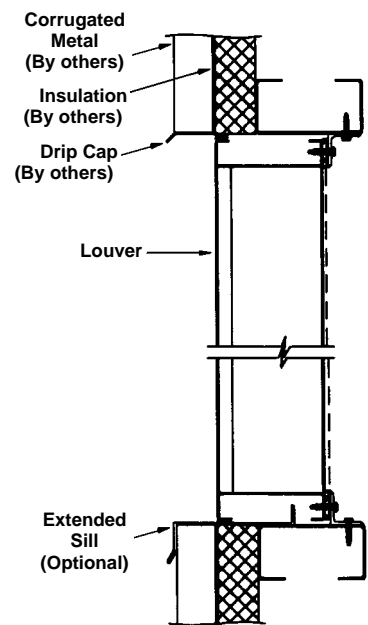
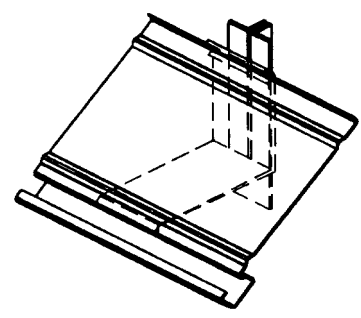
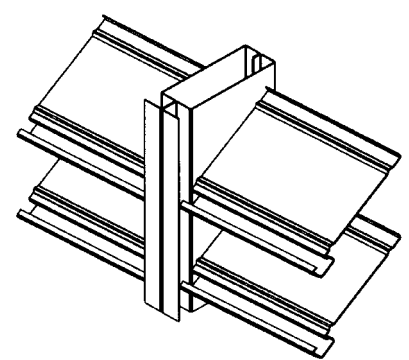
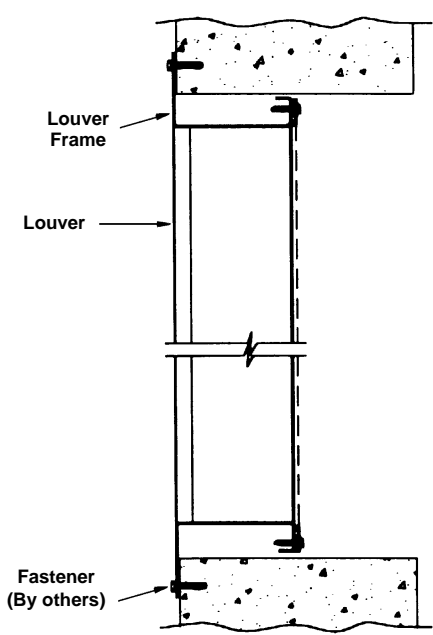
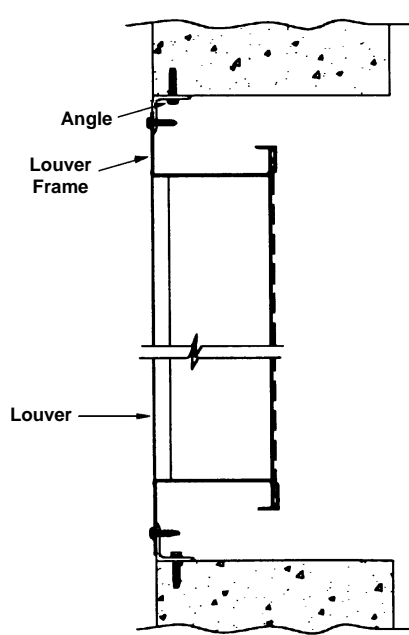
Masonry Wall	Metal Panel Wall	STANDARD CONSTRUCTION DETAILS
		 <p data-bbox="1023 735 1445 861">Hidden Vertical Blade Support (HVBS) Available up to 120" (3048)</p>
<h3>Flange Mount</h3>	<h3>Angle Subframe (Optional)</h3>	 <p data-bbox="1088 1659 1364 1743">Visible Mullion At Section Joints</p>
		

Optional items are available at additional cost.



3900 Dr. Greaves Rd.
 Kansas City, MO 64030
 (816) 761-7476
 FAX (816) 765-8955
 www.ruskin.com