

**LM6375D ADJUSTABLE DRAINABLE LOUVER
FORMED STEEL**

STANDARD CONSTRUCTION

FRAME

6" (152) deep, 16 (1.6) gauge galvanized steel. Caulking surface provided.

BLADES

16 (1.6) gauge galvanized steel drainable blades are positioned at 37¹/₂° angle and spaced approximately 4⁵/₁₆" (110) center to center.

SCREEN

1/2" (13) mesh x 19 gauge (1.1) galvanized bird screen in removable frame. Screen adds approximately 1/2" (13) to louver depth.

FINISH

Mill.

SEALS

Neoprene blade seal
Stainless steel jamb seal

LINKAGE

Concealed in frame

BEARINGS

Stainless Steel

AXLES

1/2" (13) plated steel hex.

ACTUATOR

Locking louver quadrant arm.

MINIMUM SIZE

12"w x 12"h (305 x 305).

APPROXIMATE SHIPPING WEIGHT

6 lbs. per sq. ft. (29.3 per m²).

MAXIMUM FACTORY ASSEMBLY SIZE

Shall be 60"w x 96"h (1524 x 2438) without seals. Louvers with optional blade and jamb seals shall be 48"w x 96"h (1219 x 2438). Louvers larger than the maximum factory assembly size will require field assembly of smaller sections.

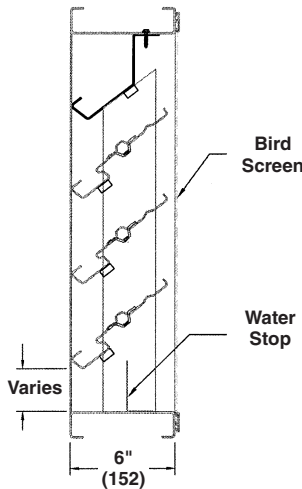
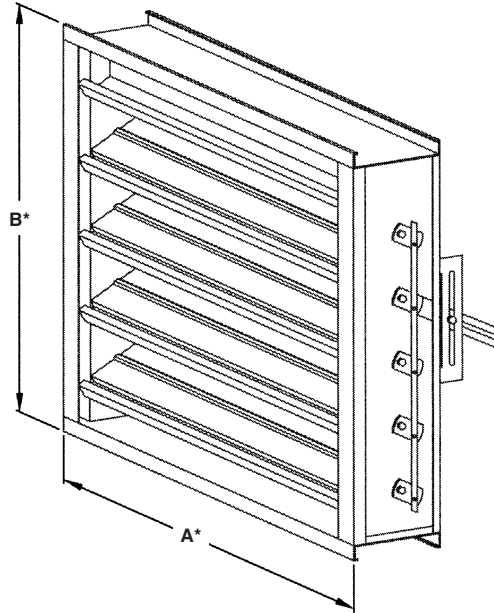

FEATURES

- Welded Construction
- Rugged galvanized steel construction ensures long operating life
- Blade and jamb seals provide tight closure
- Concealed blade linkage is protected from weather exposure and reduces required installation depth
- 51% Free Area
- Published performance ratings based on testing in accordance with AMCA Publication 511.

VARIATIONS

Variations to the basic design of this louver are available at additional cost. They include:

- Extended sill.
- A variety of bird and insect screens- aluminum, galvanized or stainless steel
- Hinged frame.
- Front or rear security bars.
- Filter racks.
- Installation angles.
- Front and Rear Flanges and Sleeves
- Special Material-18ga galvanized or stainless frame and blades
- Selection of finishes: PVDF and Pearledize 50 & 70, prime coat and epoxy
- Manual, electrical and pneumatic actuators available
- Blade edge and jamb seals
Consult Ruskin for other special requirements

FRAME CONSTRUCTION

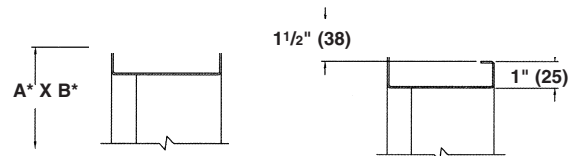

STANDARD

INTEGRAL FLANGE

Units furnished 1/4" (6) smaller than given opening dimensions.

Consult Ruskin for additional information.

Dimensions in parenthesis () indicate millimeters.

SUGGESTED SPECIFICATION

Furnish and install louvers as hereinafter specified where shown on plans or as described in schedule. Louvers shall be stationary type entirely contained within a 6" (152) frame. Louver components (heads, jambs, sills, blades & mullions) shall be factory assembled by the louver manufacturer. Louver sizes too large for shipping shall be built up by the contractor from factory assembled louver sections to provide overall sizes required. Louver design shall incorporate structural supports required to withstand a wind load of 20 lbs. per sq. ft. (.96kPa) equivalent of a 90 mph wind [145 KPH] - specifier may substitute any loading required).

Louvers shall be Ruskin Model LM6375D construction as follows:

Frame: 16 (1.6) gauge galvanized steel.

Blades: 16 (1.6) gauge galvanized steel at 37¹/₂° angle and spaced approximately 4⁵/₁₆" (110) center to center.

Screen: .50 (13) mesh x 19 gauge (13 x 1.1) galvanized steel in removable frame.

Finish: Select finish specification from Ruskin Finishes Brochure.

Published louver performance data bearing the AMCA Certified Ratings Seal for Air Performance & Water Penetration must be submitted for approval prior to fabrication and must demonstrate pressure drop and water penetration equal to or less than Ruskin model specified.

PERFORMANCE DATA

AMCA Standard 500 provides a reasonable basis for testing and rating louvers. Testing to AMCA 500 is performed under a certain set of laboratory conditions. This does not guarantee that other conditions will not occur in the actual environment where louvers must

operate. Designs should provide a reasonable safety factor for louver performance by selecting at some point below pressure drop or water penetration system requirements.

WATER PENETRATION

Test size 48" wide x 48" high (1219 x 1219)

Beginning point of water penetration at .01 oz./sq. ft. is 1038 fpm (316 m/min).

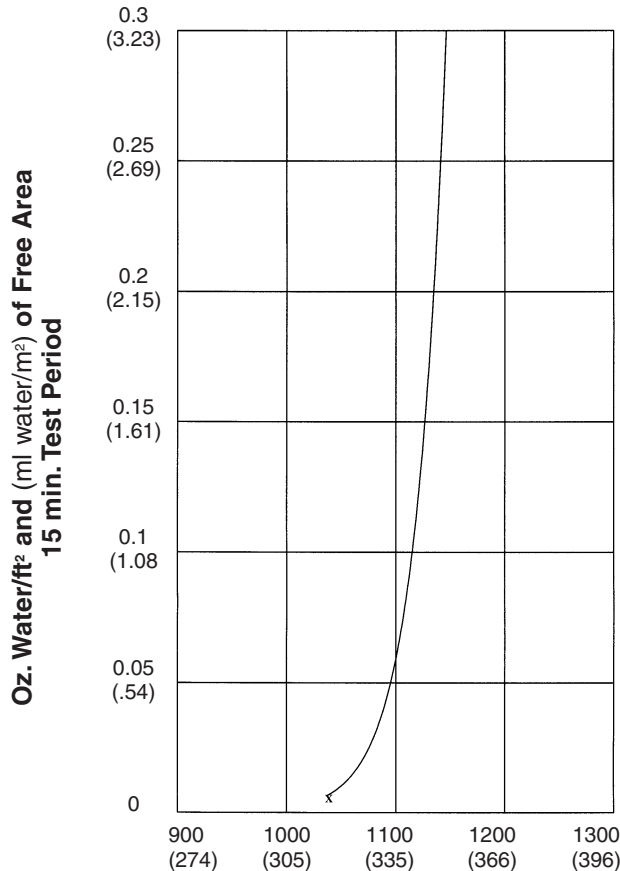

Free Area Velocity in feet (meters) per minute
Standard air .075 lb/ft³ (1.2 kg/m³)



Ruskin Manufacturing certifies that the louver shown herein is licensed to bear the AMCA Seal. The ratings shown are based on tests and procedures performed in accordance with AMCA Standard 511 and comply with the requirements of the AMCA Certified Ratings Program. AMCA Certified Ratings Seal applies to air performance and water penetration ratings only.

FREE AREA GUIDE

Free Area Guide shows free area in ft² and m² for various sizes of LM6375D.

Width – Inches and Meters

Height – Inches and Meters

	12	18	24	30	36	42	48	54	60	66	72	78	84	90	96	102	108	114	120
	0.30	0.46	0.61	0.76	0.91	1.07	1.22	1.37	1.52	1.68	1.83	1.98	2.13	2.29	2.44	2.59	2.74	2.90	3.05
18	0.24	0.38	0.53	0.68	0.82	0.97	1.12	1.26	1.41	1.55	1.70	1.85	1.99	2.14	2.29	2.43	2.58	2.72	2.87
0.46	0.02	0.04	0.05	0.06	0.08	0.09	0.10	0.12	0.13	0.14	0.16	0.17	0.19	0.20	0.21	0.23	0.24	0.25	0.27
24	0.49	0.79	1.09	1.38	1.68	1.98	2.28	2.58	2.88	3.18	3.48	3.78	4.08	4.38	4.68	4.98	5.28	5.58	5.88
0.61	0.05	0.07	0.10	0.13	0.16	0.18	0.21	0.24	0.27	0.30	0.32	0.35	0.38	0.41	0.44	0.46	0.49	0.52	0.55
30	0.74	1.19	1.64	2.09	2.55	3.00	3.45	3.90	4.36	4.81	5.26	5.71	6.17	6.62	7.07	7.52	7.98	8.43	8.88
0.76	0.07	0.11	0.15	0.19	0.24	0.28	0.32	0.36	0.41	0.45	0.49	0.53	0.57	0.62	0.66	0.70	0.74	0.78	0.83
36	0.98	1.59	2.20	2.80	3.41	4.01	4.62	5.22	5.83	6.44	7.04	7.65	8.25	8.86	9.46	10.07	10.67	11.28	11.89
0.91	0.09	0.15	0.20	0.26	0.32	0.37	0.43	0.49	0.54	0.60	0.65	0.71	0.77	0.82	0.88	0.94	0.99	1.05	1.11
42	1.48	2.39	3.31	4.22	5.13	6.04	6.95	7.87	8.78	9.69	10.60	11.51	12.42	13.34	14.25	15.16	16.07	16.98	17.90
1.07	0.14	0.22	0.31	0.39	0.48	0.56	0.65	0.73	0.82	0.90	0.99	1.07	1.16	1.24	1.33	1.41	1.49	1.58	1.66
48	1.73	2.80	3.86	4.93	5.99	7.06	8.12	9.19	10.25	11.32	12.38	13.45	14.51	15.58	16.64	17.71	18.77	19.84	20.90
1.22	0.16	0.26	0.36	0.46	0.56	0.66	0.76	0.85	0.95	1.05	1.15	1.25	1.35	1.45	1.55	1.65	1.75	1.84	1.94
54	1.98	3.20	4.42	5.63	6.85	8.07	9.29	10.51	11.72	12.94	14.16	15.38	16.60	17.82	19.03	20.25	21.47	22.69	23.91
1.37	0.18	0.30	0.41	0.52	0.64	0.75	0.86	0.98	1.09	1.20	1.32	1.43	1.54	1.66	1.77	1.88	2.00	2.11	2.22
60	2.23	3.60	4.97	6.34	7.71	9.08	10.46	11.86	13.20	14.57	15.94	17.31	18.68	20.06	21.43	22.80	24.17	25.54	26.91
1.52	0.21	0.33	0.46	0.59	0.72	0.84	0.97	1.10	1.23	1.36	1.48	1.61	1.74	1.87	1.99	2.12	2.25	2.38	2.50
66	2.48	4.00	5.53	7.05	8.57	10.10	11.62	13.15	14.67	16.20	17.72	19.25	20.77	22.29	23.82	25.34	26.87	28.39	29.92
1.68	0.23	0.37	0.51	0.66	0.80	0.94	1.08	1.22	1.36	1.51	1.65	1.79	1.93	2.07	2.22	2.36	2.50	2.64	2.78
72	2.73	4.40	6.08	7.76	9.44	11.11	12.79	14.47	16.15	17.82	19.50	21.28	22.86	24.53	26.21	27.89	29.57	31.24	32.92
1.83	0.25	0.41	0.57	0.72	0.88	1.03	1.19	1.35	1.50	1.66	1.81	1.97	2.13	2.28	2.44	2.59	2.75	2.91	3.06
78	2.97	4.81	6.64	8.47	10.30	12.13	13.96	15.79	17.62	19.45	21.28	23.11	24.94	26.77	28.60	30.43	32.27	34.10	35.93
1.98	0.28	0.45	0.62	0.79	0.96	1.13	1.30	1.47	1.64	1.81	1.98	2.15	2.32	2.49	2.66	2.83	3.00	3.17	3.34
84	3.22	5.21	7.19	9.18	11.16	13.14	15.13	17.11	19.09	21.08	23.06	25.05	27.03	29.01	31.00	32.98	34.96	36.95	38.93
2.13	0.30	0.48	0.67	0.85	1.04	1.22	1.41	1.59	1.78	1.96	2.14	2.33	2.51	2.70	2.88	3.07	3.25	3.44	3.62
90	3.47	5.61	7.75	9.88	12.02	14.16	16.29	18.43	20.57	22.70	24.84	26.98	29.12	31.25	33.39	35.53	37.66	39.80	41.94
2.29	0.32	0.52	0.72	0.92	1.12	1.32	1.52	1.71	1.91	2.11	2.31	2.51	2.71	2.91	3.11	3.30	3.50	3.70	3.90
96	3.72	6.01	8.30	10.59	12.88	15.17	17.46	19.75	22.04	24.33	26.62	28.91	31.20	33.49	35.78	38.07	40.36	42.65	44.94
2.44	0.34	0.55	0.77	0.99	1.20	1.41	1.62	1.84	2.05	2.26	2.48	2.69	2.90	3.11	3.33	3.54	3.75	3.97	4.18

PRESSURE DROP

Test size 48" x 48" (1219 x 1219)

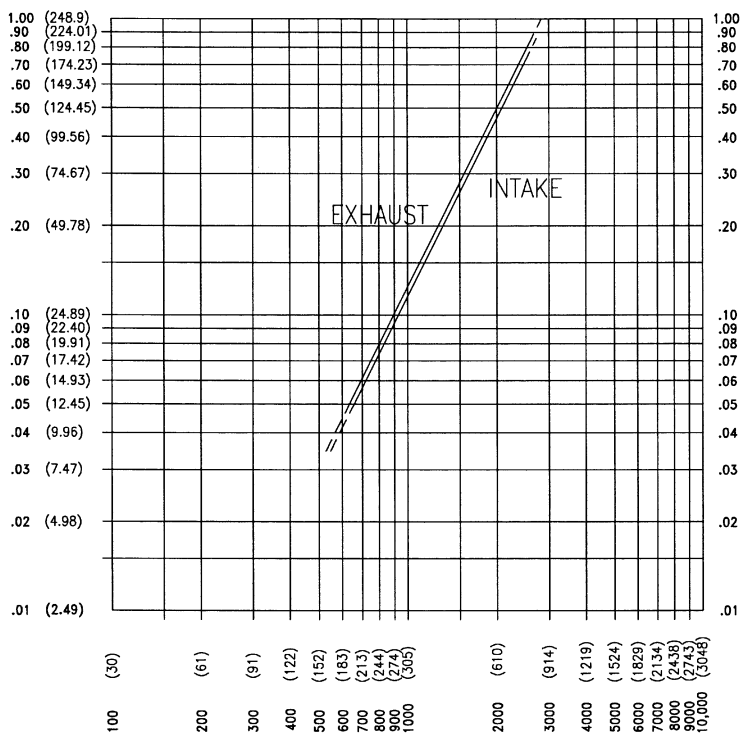

Ratings do not include the effect of a bird screen.

Air Velocity in feet (meters) per minute through Free Area



3900 Dr. Greaves Rd.
 Kansas City, MO 64030
 (816) 761-7476
 FAX (816) 765-8955
 www.ruskin.com