

Tag: _____ **Engineer:** _____
Project: _____ **Contractor:** _____
Location: _____ **Architect:** _____
Date: _____ **Submitted By:** _____



MODEL SLD-6-GL Formed Stationary Louver

Drainable Blade, AMCA Licensed

Standard Construction

- FRAME:** 6" (152) x 20 ga. galvanized steel
- BLADES:** 20 ga. galvanized steel,
Drainable Blades fixed at 37.5° angle,
Spaced approximately 4-3/4" (121)
- SCREEN:** Bird screen - 1/2" (12.7) x 1/2" (12.7) x 19 ga. galvanized steel with a removable frame on the interior of the louver. Screen adds approximately 1/2" (12.7) to depth of louver.
- FINISH:** Mill galvanized
- MINIMUM SIZE:** 6"w (152) x 12"h (305)
- MAXIMUM ASSEMBLY SIZE:** Single Sections will not exceed 120"w (3048) x 90"h (2286) or 90"w (2286) x 120"h (3048). Larger sizes will require field assembly of smaller sections.
- DESIGN LOAD:** 20 psf (97.6 kg/m²) Consult for higher pressures.

All dimensions shown in inches, parenthesis () indicate millimeters.

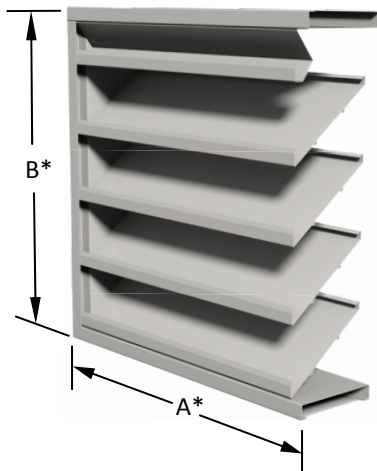

LEED Material Information

VOC Content (g/L) - 0

Manufacturing Location (MR 5.1)
• Marion, NC 28752

* Width [A dimension] and Height [B dimension] are approximately 1/4" (6) under listed size, unless otherwise specified.

Optional Construction

- Sill Extension
- Flange Frame [1 1/2" (38)]
- Welded Construction
- Filter Racks
- Security Bars:
 - Front
 - Rear
- Optional Bird and Insect Screens
- Optional Finishes: Consult Finishes Chart
- Blank Off Panel:
 - Galvanized Steel, Non-Insulated
 - Galvanized Steel, Insulated
- Alternate materials
 - 18 ga. galvanized steel
 - 16 ga. galvanized steel
 - 14 ga. galvanized steel
 - 304 Stainless Steel
 - 316 Stainless Steel

Consult NCA for Other Special Requirements

Frame Options

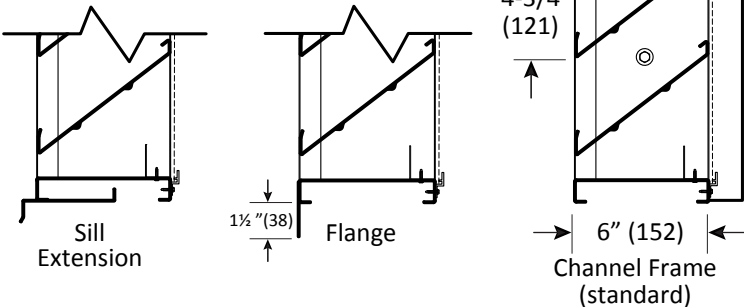

Note: Blade supports may be added as necessary. Blade supports will increase overall depth of louver; exact amount is dependent upon louver size, assembly configuration or windload requirements.

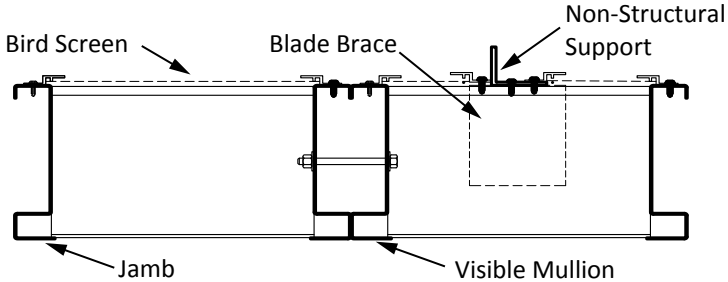

Note: Concealed (Architectural) mullions are not recommended with drainable blade products.

SLD-6-GL - 0613 / Replaces SLD-6-GL-0205

All Stated Specifications Are Subject to Change Without notice or Obligation.

FREE AREA GUIDE FOR SLD-6-GL

(Free area in ft² and m²)

Width in Inches (Meters)

		12	18	24	30	36	42	48	54	60	66	72	78	84	90	96	102	108	114	120
		0.30	0.46	0.61	0.76	0.91	1.07	1.22	1.37	1.52	1.68	1.83	1.98	2.13	2.29	2.44	2.59	2.74	2.90	3.05
Height in Inches (Meters)	12	0.34	0.55	0.76	0.97	1.17	1.38	1.59	1.80	2.01	2.22	2.42	2.63	2.84	3.05	3.26	3.47	3.68	3.88	4.09
	0.30	0.03	0.05	0.07	0.09	0.11	0.13	0.15	0.17	0.19	0.21	0.23	0.24	0.26	0.28	0.30	0.32	0.34	0.36	0.38
	18	0.65	1.04	1.44	1.83	2.23	2.62	3.02	3.42	3.81	4.21	4.60	5.00	5.39	5.79	6.18	6.58	6.98	7.37	7.77
	0.46	0.06	0.10	0.13	0.17	0.21	0.24	0.28	0.32	0.35	0.39	0.43	0.46	0.50	0.54	0.58	0.61	0.65	0.69	0.72
	24	0.85	1.37	1.89	2.41	2.93	3.45	3.97	4.49	5.01	5.53	6.05	6.57	7.09	7.61	8.13	8.65	9.17	9.69	10.21
	0.61	0.08	0.13	0.18	0.22	0.27	0.32	0.37	0.42	0.47	0.51	0.56	0.61	0.66	0.71	0.76	0.80	0.85	0.90	0.95
	30	1.16	1.86	2.57	3.28	3.98	4.69	5.40	6.11	6.81	7.52	8.23	8.93	9.64	10.35	11.05	11.76	12.47	13.17	13.88
	0.76	0.11	0.17	0.24	0.30	0.37	0.44	0.50	0.57	0.63	0.70	0.76	0.83	0.90	0.96	1.03	1.09	1.16	1.23	1.29
	36	1.46	2.36	3.25	4.15	5.04	5.93	6.83	7.72	8.62	9.51	10.40	11.30	12.19	13.09	13.98	14.87	15.77	16.66	17.56
	0.91	0.14	0.22	0.30	0.39	0.47	0.55	0.63	0.72	0.80	0.88	0.97	1.05	1.13	1.22	1.30	1.38	1.47	1.55	1.63
	42	1.77	2.85	3.93	5.01	6.09	7.18	8.26	9.34	10.42	11.50	12.58	13.66	14.74	15.82	16.91	17.99	19.07	20.15	21.23
	1.07	0.16	0.27	0.37	0.47	0.57	0.67	0.77	0.87	0.97	1.07	1.17	1.27	1.37	1.47	1.57	1.67	1.77	1.87	1.97
	48	1.97	3.18	4.38	5.59	6.79	8.00	9.21	10.41	11.62	12.82	14.03	15.23	16.44	17.64	18.85	20.05	21.26	22.46	23.67
	1.22	0.18	0.30	0.41	0.52	0.63	0.74	0.86	0.97	1.08	1.19	1.30	1.42	1.53	1.64	1.75	1.86	1.98	2.09	2.20
	54	2.28	3.67	5.06	6.46	7.85	9.24	10.63	12.03	13.42	14.81	16.20	17.60	18.99	20.38	21.77	23.17	24.56	25.95	27.34
	1.37	0.21	0.34	0.47	0.60	0.73	0.86	0.99	1.12	1.25	1.38	1.51	1.64	1.77	1.90	2.02	2.15	2.28	2.41	2.54
	60	2.59	4.16	5.74	7.32	8.90	10.48	12.06	13.64	15.22	16.80	18.38	19.96	21.54	23.12	24.70	26.28	27.86	29.44	31.02
	1.52	0.24	0.39	0.53	0.68	0.83	0.97	1.12	1.27	1.42	1.56	1.71	1.86	2.00	2.15	2.30	2.44	2.59	2.74	2.88
	66	2.89	4.66	6.43	8.19	9.96	11.73	13.49	15.26	17.03	18.79	20.56	22.33	24.09	25.86	27.63	29.39	31.16	32.93	34.69
1.68	0.27	0.43	0.60	0.76	0.93	1.09	1.25	1.42	1.58	1.75	1.91	2.08	2.24	2.40	2.57	2.73	2.90	3.06	3.23	
72	3.09	4.99	6.88	8.77	10.66	12.55	14.44	16.33	18.22	20.11	22.00	23.90	25.79	27.68	29.57	31.46	33.35	35.24	37.13	
1.83	0.29	0.46	0.64	0.82	0.99	1.17	1.34	1.52	1.69	1.87	2.05	2.22	2.40	2.57	2.75	2.93	3.10	3.28	3.45	
78	3.40	5.48	7.56	9.64	11.71	13.79	15.87	17.95	20.03	22.10	24.18	26.26	28.34	30.42	32.49	34.57	36.65	38.73	40.81	
1.98	0.32	0.51	0.70	0.90	1.09	1.28	1.48	1.67	1.86	2.06	2.25	2.44	2.64	2.83	3.02	3.22	3.41	3.60	3.80	
84	3.71	5.97	8.24	10.50	12.77	15.03	17.30	19.56	21.83	24.09	26.36	28.63	30.89	33.16	35.42	37.69	39.95	42.22	44.48	
2.13	0.34	0.56	0.77	0.98	1.19	1.40	1.61	1.82	2.03	2.24	2.45	2.66	2.87	3.08	3.29	3.50	3.72	3.93	4.14	
90	4.01	6.47	8.92	11.37	13.82	16.28	18.73	21.18	23.63	26.09	28.54	30.99	33.44	35.89	38.35	40.80	43.25	45.70	48.16	
2.29	0.37	0.60	0.83	1.06	1.29	1.51	1.74	1.97	2.20	2.43	2.65	2.88	3.11	3.34	3.57	3.79	4.02	4.25	4.48	
96	4.22	6.79	9.37	11.95	14.52	17.10	19.68	22.25	24.83	27.41	29.98	32.56	35.14	37.71	40.29	42.87	45.44	48.02	50.60	
2.44	0.39	0.63	0.87	1.11	1.35	1.59	1.83	2.07	2.31	2.55	2.79	3.03	3.27	3.51	3.75	3.99	4.23	4.47	4.71	

PRESSURE DROP

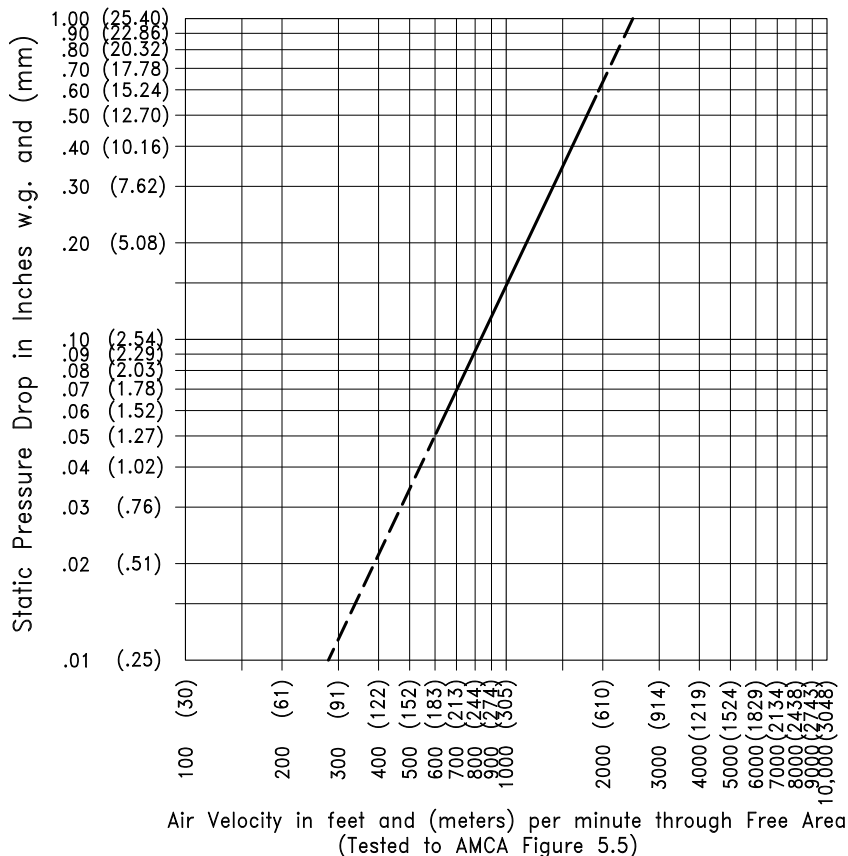

NCA Manufacturing Inc. certifies that the Model **SLD-6-GL** louver shown herein is certified to bear the AMCA seal. The ratings shown are based on tests and procedures performed in accordance with AMCA Publication 511 and comply with the requirements of the AMCA Certified Ratings Program.

The AMCA Certified Ratings Seal applies to air performance ratings and water penetration ratings only.

Beginning Point of Water Penetration at .01oz./ft² is **1084 FPM (330 m/min)** Free Area Velocity.

Notes:

- Pressure Drop and Water Penetration Data applies to test unit size 48" w x 48" h (1219 x 1219) only.
- Reported Pressure Drop is for Intake only.
- Performance data does not include the effects of bird screen.
- All Performance shown is at standard air density of 0.075 lb/ft³ (1.2 kg/m³).
- Water Penetration data is for 15 minute test duration