

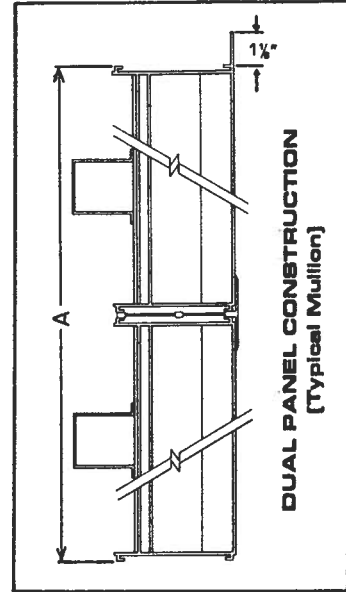

CERTIFICATION & SUBMITTAL
MODEL 2400 AJUST-O-VENT COMBINATION DAMPER/LOUVER
Drainable Blade Air Intake/Exhaust

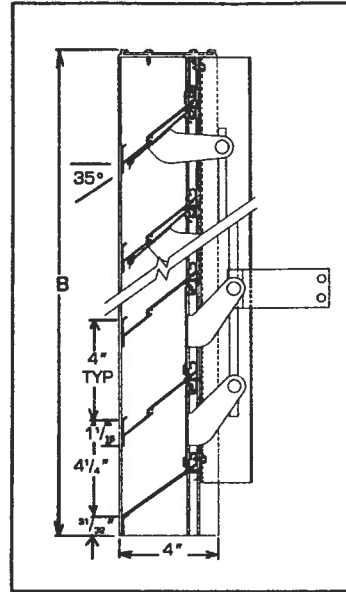
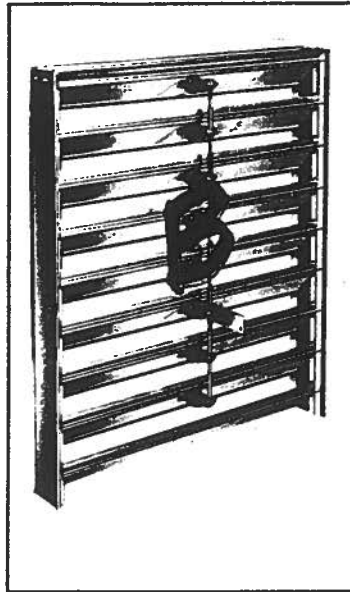
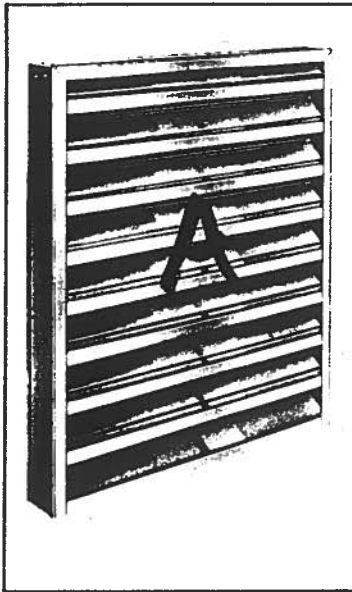

STANDARD SPECIFICATIONS

- **FRAME:** .081 6063T5 extruded aluminum.
- **BLADES:** .072 6063T5 extruded aluminum with full length pivoting.
- **BIRDSCREEN:** .051 x 3/4" diamond pattern expanded aluminum.
- **HARDWARE:** Plated steel center brackets; brass pivots; 1/16" dia. plated steel linkage rod.
- **OPERATING ARM:** 14 ga. galvanized steel.
- **COVER CHANNEL:** .063 aluminum.
- **BLADE EDGE SEAL:** Vinyl gasketing extending full length of adjustable blades.
- **FINISH:** Standard Mill.
- **MAXIMUM SINGLE SECTION:** 60" x 60", 48" x 72", 24" x 96"
- **MINIMUM SIZE:** 12" x 12".

OPTIONS

- 31 Flange.
- 32 Multiple Section.
- 34 Buck Frame.
- 35 Sill Extension.
- 40 Standard Screen in removable frame.
- 42 18" x 16" Mesh aluminum insect screen.
- 43 18" x 16" Mesh bronze insect screen.
- 44 1/2" x 1/2" x 16 Gauge S.S. screen.
- 45 1/2" x 1/2" x .063 Aluminum screen.
- 89 Sleeve.
- 90 Jackshaft.
- 92 Operators.

NOTE: A and B are opening dimensions. Unless otherwise specified, louvers are made 1/4" undersize.

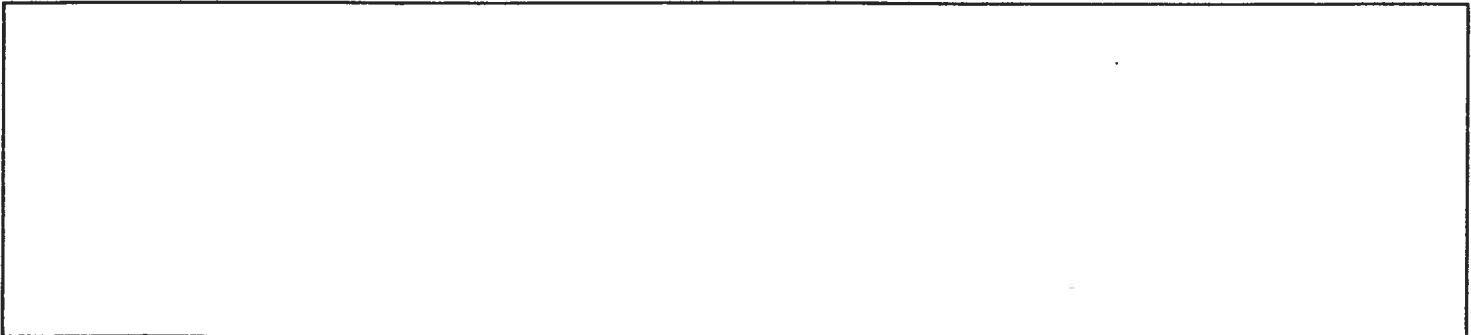



PERFORMANCE DATA MODEL 2400 EXTRUDED ALUMINUM COMBINATION DAMPER/LOUVER Drainable Blade Air Intake/Exhaust

Vent Products certifies that the Model 2400 Louver shown herein is licensed to bear the AMCA Seal. The ratings shown are based on the tests and procedures performed in accordance with AMCA Publication 511 and comply with the requirements of the AMCA Certified Ratings Program. The AMCA Certified Ratings Seal applies to air performance ratings and water penetration ratings.

FREE AREA CHART

		A WIDTH (In Inches)												
		12	16	20	24	28	32	36	40	44	48	52	56	60
B HEIGHT (In Inches)	12	.15	.21	.28	.34	.41	.47	.53	.60	.66	.73	.79	.85	.92
	16	.30	.43	.55	.68	.81	.94	1.07	1.20	1.32	1.45	1.58	1.71	1.84
	20	.45	.64	.83	1.02	1.22	1.41	1.60	1.79	1.99	2.18	2.37	2.56	2.76
	24	.59	.85	1.11	1.36	1.62	1.88	2.14	2.39	2.65	2.91	3.16	3.42	3.68
	28	.74	1.06	1.38	1.71	2.03	2.35	2.67	2.99	3.31	3.63	3.95	4.27	4.60
	32	.89	1.28	1.66	2.05	2.43	2.82	3.20	3.59	3.97	4.36	4.74	5.13	5.52
	36	1.04	1.49	1.94	2.39	2.84	3.29	3.74	4.19	4.64	5.09	5.54	5.98	6.43
	40	1.19	1.70	2.21	2.73	3.24	3.76	4.27	4.78	5.30	5.81	6.33	6.84	7.35
	44	1.34	1.91	2.49	3.07	3.65	4.23	4.80	5.38	5.96	6.54	7.12	7.69	8.27
	48	1.48	2.13	2.77	3.41	4.05	4.70	5.34	5.98	6.62	7.27	7.91	8.55	9.19
	52	1.63	2.34	3.05	3.75	4.46	5.17	5.87	6.58	7.29	7.99	8.70	9.40	10.11
	56	1.78	2.55	3.32	4.09	4.86	5.63	6.41	7.18	7.95	8.72	9.49	10.26	11.03
	60	1.93	2.76	3.60	4.43	5.27	6.10	6.94	7.77	8.61	9.44	10.28	11.11	11.95
	64	2.08	2.98	3.88	4.78	5.67	6.57	7.47	8.37	9.27	10.17	11.07	11.97	12.87
	68	2.23	3.19	4.15	5.12	6.08	7.04	8.01	8.97	9.93	10.90	11.86	12.82	13.79
	72	2.37	3.40	4.43	5.46	6.49	7.51	8.54	9.57	10.60	11.62	12.65	13.68	14.71
76	2.52	3.61	4.71	5.80	6.89	7.98	9.07	10.17	11.26	12.35	13.44	14.53	15.63	
80	2.67	3.83	4.98	6.14	7.30	8.45	9.61	10.76	11.92	13.08	14.23	15.39	16.55	
84	2.82	4.04	5.26	6.48	7.70	8.92	10.14	11.36	12.58	13.80	15.02	16.24	17.47	
88	2.97	4.25	5.54	6.82	8.11	9.39	10.68	11.96	13.25	14.53	15.81	17.10	18.38	
92	3.12	4.47	5.81	7.16	8.51	9.86	11.21	12.56	13.91	15.26	16.61	17.95	19.30	
96	3.26	4.68	6.09	7.50	8.92	10.33	11.74	13.16	14.57	15.98	17.40	18.81	20.22	

FREE AREA (sq. ft.)

AIR PERFORMANCE TEST

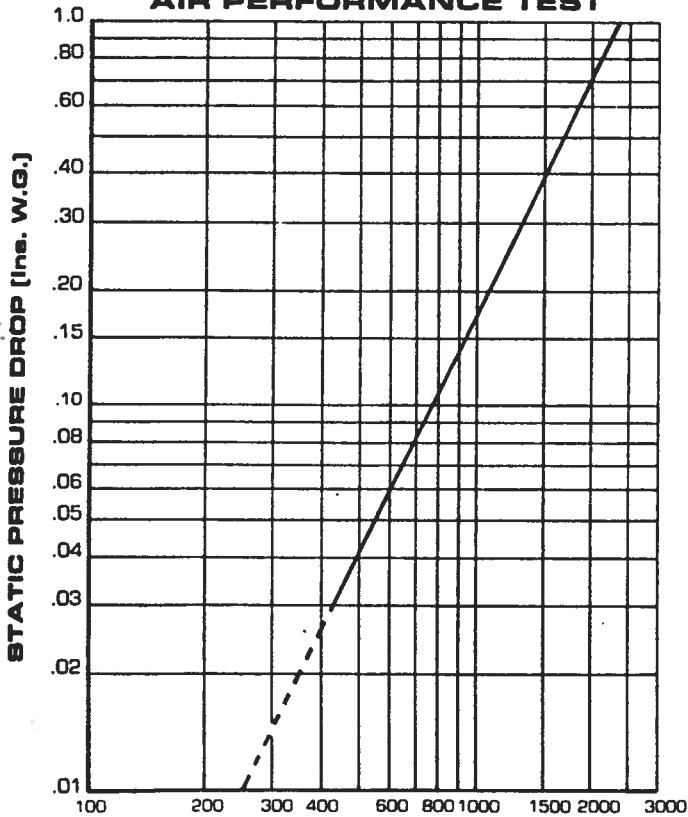

FREE AREA VELOCITY F.P.M.

Air Performance data reflects both intake and exhaust modes.

WATER PENETRATION CHART

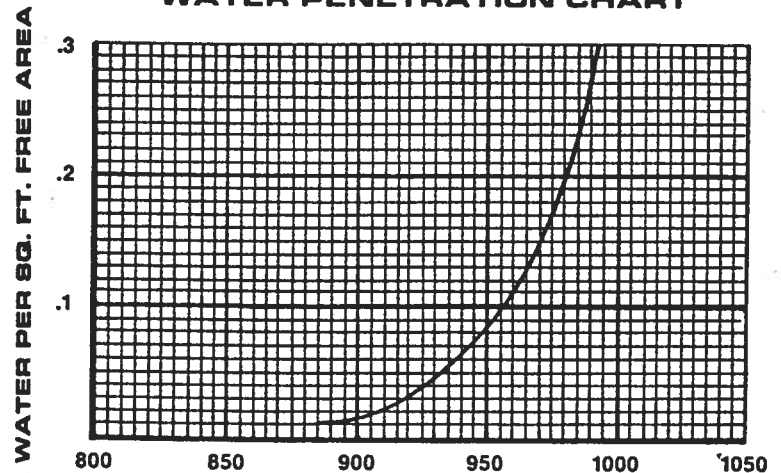

FREE AREA VELOCITY F.P.M.

(15 Min. Duration)

THE BEGINNING OF WATER PENETRATION IS 880 FPM

It is possible for moisture to penetrate louvers under adverse atmospheric conditions. For critical applications, drained ductwork or other means of drainage is recommended.

Data shown does not include the effect of the birdscreen.

Graphs are corrected to standard air density .075 lb. per cubic foot.

TEST UNIT SIZE 48" x 48"

RECOMMENDED MAXIMUM INTAKE FREE AREA VELOCITY 800 F.P.M.