



罡鼎有限公司
CIRCLE & CYCLE LTD.

CDB Series BC Centrifugal Fan

罡鼎雙吸後傾風機



CIRCLE & CYCLE CDB Series Centrifugal Fan

Circle & Cycle Ltd. certifies that the CDB series model 250 to 1000 shown herein is licensed to bear the AMCA seal.

The ratings shown are based on tests and procedures performed in accordance with AMCA Publication 211 and AMCA Publication 311 and comply with the requirements of the AMCA Certified Ratings Program.

罡鼎有限公司特此證明，此處所示 CDB 系列目錄中型號從 250 到 1000，獲得了加蓋 AMCA 印章的授權。

所示額定值係根據 AMCA 出版物 211 和 AMCA 出版物 311 所進行測試和程序確定，並符合 AMCA 認證額定值計劃的要求。



罡鼎有限公司



The characteristics of the machines stated in this catalogue, like dimensions, performances and so on can be modified without prior notice. Copyright Circle & Cycle Ltd - All rights reserved.
本目錄中所述的風機特性，如尺寸、性能參數等，可能進行修改，修改時恕不事先通知。
本本文中所使用之各項商標及企業識別圖示，均為其合法所有人之財產；未經書面同意，禁止任何形式之轉載。

CDB 罌鼎雙吸後傾式風機

▶ 離心式風機的主要結構：

離心風機的主要結構包括以下說明：

規格特徵

- 罌鼎有限公司所生產的離心式風機具有結構合理、流量大、噪音低、壓力高、安裝方便等優點。該風機適用於一般工廠及大型建築物的室內通風換氣。
- 罌鼎後傾離心式風機為 CDB 系列風機為雙進風、後傾離心式風機。且通過國際 AMCA 標準：205[能效等級]、210[性能]、300[噪音] 之嚴格認證 !! 該風機主要由葉輪、機殼、進風口、支架等部件組立配成，再搭配傳動部件構成完整的產品。其產品設計成以下幾種結構形式，從小型、標準結構到加強版結構依 AMCA 99 次序排列為：K 型 (CL.II) / G 型 (CL.III) 兩種通風形式。尺寸從 250 至 1000 mm，全壓最高可達到 3000 Pa。
- 雙入口型離心風機之進口端附加裝鐘型口 (Bell Mouth)；由裝設之馬達直接或皮帶驅動，提供高效能的運轉，運轉效率可達到 81% 以上，其風量性能可從由 1,000 m³/h 達到 120,000 m³/h。對於 CDB 系列，根據客戶要求，可提供輸送 280°C 氣體的風機；風機用於輸送不易燃燒、無腐蝕性氣體，含塵量和其他固體含量不大於 100 g/m³，環境溫度 - 20°C ~40°C，也可按 AMCA 標準要求加工使用鋁合金或玻璃纖維材質製作進風口的防火花風機。

傳動組件

- 傳動部份由主軸、軸承箱、滾動軸承、皮帶輪或聯軸器組成。主軸採用優質碳鋼製成，轉軸均為經研磨及拋光處理之實心或空心鋼軸。經調質處理後，在設計上有可靠的安全性和抗疲勞性。風機的葉輪及皮帶輪均以栓接或鏈接至鍵上，並用止擋螺絲固定於主軸上。
- 軸承配用自動調心軸承，使用連座軸承 (Pillow Block type) 或滾珠軸承 (Ball Bearing)，大型者則用滾筒軸承 (Roller Bearing)。軸承座 (箱) 為優質鑄鐵件加工而成，耐防塵保養容易，標準規格採用油脂或機油潤滑，如採特殊或高溫運轉時可使用水冷或油冷系統方式冷卻。

轉子組件

風機葉輪由後傾圓弧型葉片、曲線型輪蓋和平板型輪盤及輪殼組成，由後傾 (機翼) 形葉片焊接於弧錐形的輪蓋與平板型的轉盤中間，具有良好空氣動力性能和運轉的平穩可靠性。葉輪之輪轂均以防銹蝕、抗氧化的合金材質製造成形。葉片特色為採後傾 (翼截) 式的設計，固定於中板上。葉輪總成以鎖緊裝置直接固定於驅動主軸上，適合所指定的操作速度、溫度、壓力及流量；每組葉輪均並經過依 AMCA 204 或 ISO 1940 標準執行靜、動態平衡校正。

風機外殼

- 主要為標準 G.I. 或 CS 鋼材、SUS304 不銹鋼材質的蝸卷型外殼，厚度依尺寸大小從 1.2 至 5 mm。蝸形殼採用連續鎖定或銲工接著的精密加工方式附著在側板的結構上，可保證機殼的一體成型與強度堅固、穩定；且按空氣動力特性製造安裝，也和葉片徑向間隙均一。
- 整體法蘭為連續焊接或旋壓翻邊成形於出口端之外緣，並有等距之螺栓孔位便於和管路或消音器、風門等裝置連接使用。

罌鼎有限公司



The characteristics of the machines stated in this catalogue, like dimensions, performances and so on can be modified without prior notice. Copyright Circle & Cycle Ltd - All rights reserved.
本目錄中所述的風機特性，如尺寸、性能參數等，可能進行修改，修改時恕不事先通知。
本本文中所使用之各項商標及企業識別圖示，均為其合法所有人之財產；未經書面同意，禁止任何形式之轉載。

CIRCLE & CYCLE CDB Series Centrifugal Fan

●機殼採用先進的蝸線形狀用鋼板焊接而成的蝸形體，機殼可作為兩種不同形式：No.#250 - 1000 機殼作為整體，不能拆開。而 No.#1120-1600 大尺寸風機的外殼採分段建造機殼作成二開式，沿中心水平面分開，連接部分用螺栓及螺柱連接。以便允許在工地安裝時能夠進出結構的開口，進行安裝或拆除。當風機之葉輪直徑超過 550 mm 時，在風機殼板的開口上提供一具有壓力門門的蓋板，以供檢視之用途。

風切片

加裝於葉輪的前方出口處，符合空氣力學的外形，以期達到順風導流的效果；使流場係經一理想通過的形狀，故噪音可比一般機種低 3-5 dB。材質與外殼同等抗腐蝕之功能。

導風圈

和風機本體一併提供。且採用螺栓直接與風機側板之入口兩端固定。進風口製成空氣力學之流線型整體結構，均以沖壓或旋壓拉伸工法一次成型，具有光滑流線型表面。使空氣能均勻的進入整個入口的型式，與軸向平行的截面，為流線型具有理想的形狀能使氣體順利進入葉輪，且損失較小而實現高效低噪的性能表現。

馬達

CDB 系列離心式風機所搭配的馬達種類為低壓三相鼠籠式感應電動機 (SCIM)，冷卻方式：全密閉外扇型 (TEFC) 或全密閉空冷型 (TEAO)，或其它指定之規格，例如：防爆等級。馬達絕緣等級至少為 Ins. Class E 或 B/F 等級或依客戶指定的特別型號。保護等級為 IP54 或 IP55 也可依客戶需求亦可改造提供 IP-65 或更高等級。時間額定為在連續使用額定之使用係數 S.F.: 1.0(50Hz) / 1.15(60Hz)。軸承壽命依據 AFBM L-10 額定值要求，軸承至少具有 50,000 小時之操作壽命。出口導線可接至風機本體機殼上的選配的接線盒。也可指定選用帶有潤滑油脂補給裝置的配件，外接金屬軟管接至風機本體機殼上的補給用油脂接頭，並覆以防塵蓋以隔離水份及髒物。如有選購時的特殊需求，如馬達在其底殼上提供一排水栓，也可搭配訂製。

表面處理

外表除不銹鋼材質為原色呈現外，一般鋼材採防腐蝕保護措施，其保護方式可以選擇鍍鋅鋼板 (G.I. Sheet)、熱浸鍍鋅 (H.D.G.)、噴漆塗裝處理或特殊環氧樹脂漆 (Epoxy) 處理。外形美觀並防腐蝕、氧化防銹性能優良。

共同底座

離心式風機可提供一整合式鋼製底座，採全焊式構造焊接具有足夠的剛度，其設計強度足夠的支持力來支撐整組風機及馬達之重量，且能在規定的條件下運轉無虞。

其它選購配件

監控裝置及元件

加裝於機組上的振動、工作溫度、運轉狀態等 PTC, PT-100, SPM, Vibration 的感測元件，也可依客戶需求亦可提供加裝。(選購另件)

配件

根據需要可提供下列配件，加裝於機組上的法蘭、配套法蘭、撓性連接支撐底座皮帶張力止擋裝置等。也可依 AMCA 99 的標準，在入口圈防火花的應用中提供鋁、銅、黃銅材質；也可依客戶需求亦可提供加裝。(選購另件)

昱鼎有限公司



The characteristics of the machines stated in this catalogue, like dimensions, performances and so on can be modified without prior notice. Copyright Circle & Cycle Ltd - All rights reserved.
本目錄中所述的風機特性，如尺寸、性能參數等，可能進行修改，修改時恕不事先通知。
本本文中所有之各項商標及企業識別圖示，均為其合法所有人之財產；未經書面同意，禁止任何形式之轉載。



DOUBLE INLET CENTRIFUGAL FANS

CDB 250

WITH BACKWARD CURVED BLADES

Gas Density
氣體密度
1.2 kg/m³

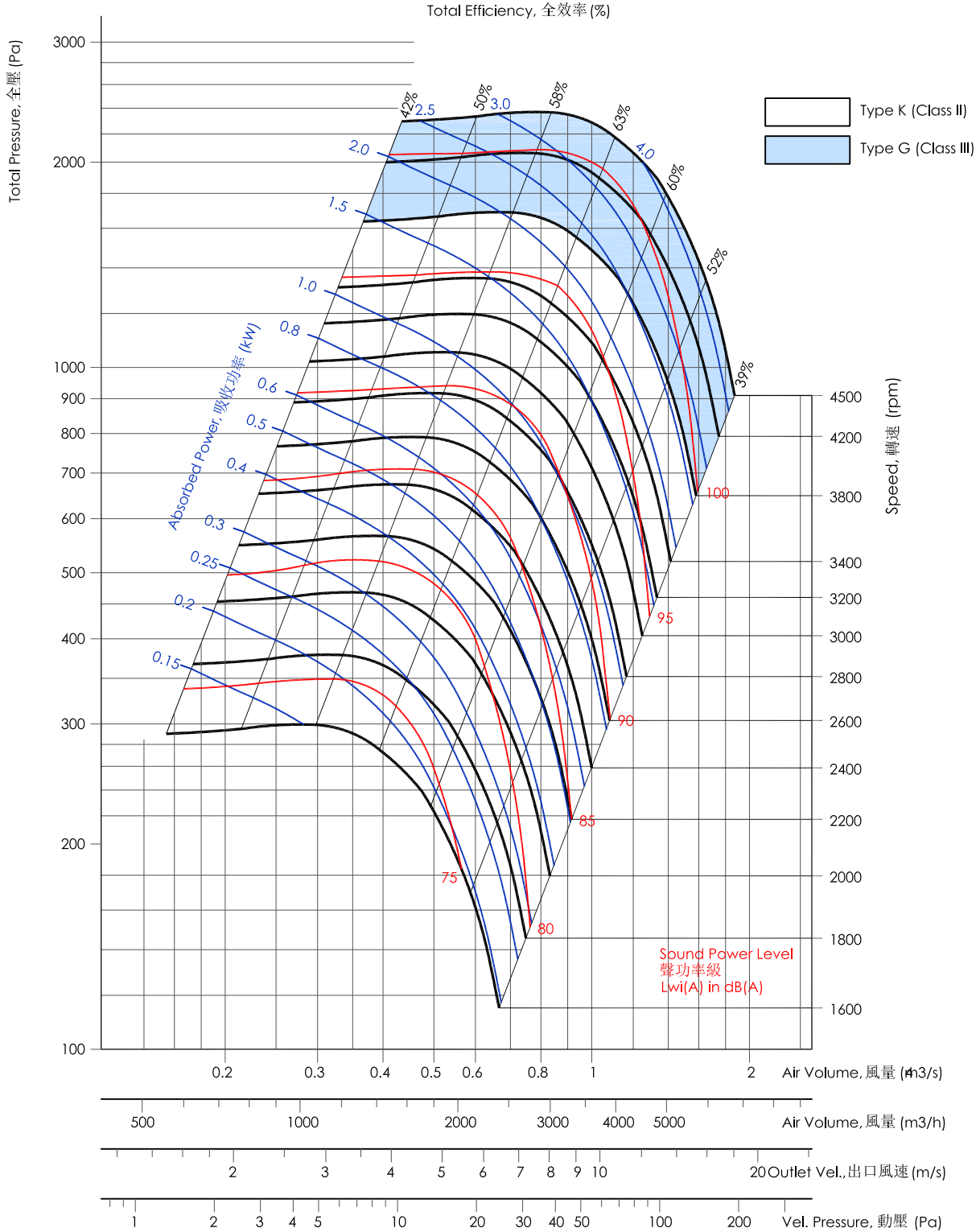

- Performance certified is for installation type B - Free inlet, Ducted outlet. Power rating (kW) does not include transmission losses. Performance ratings do not include the effects of appurtenances (accessories).
- The A-weighted sound ratings shown have been calculated per AMCA International Standard 301. Value shown are for inlet Lw(A) sound power levels for Installation type B - free inlet, ducted outlet.

- 經認證的性能是B類安裝 - 自由入口, 管道出口。功率額定值 (kW) 不包括傳輸(動)損失。各項性能額定值不包括附屬物(附件)的影響。
- 所示A加權聲音性能額定值已按AMCA International標準301計算。所示值為安裝類型 B: 自由入口, 管道出口的聲功率級 (入口Lw(A))。





DOUBLE INLET CENTRIFUGAL FANS **CDB 280**

WITH BACKWARD CURVED BLADES

Gas Density
氣體密度
1.2 kg/m³

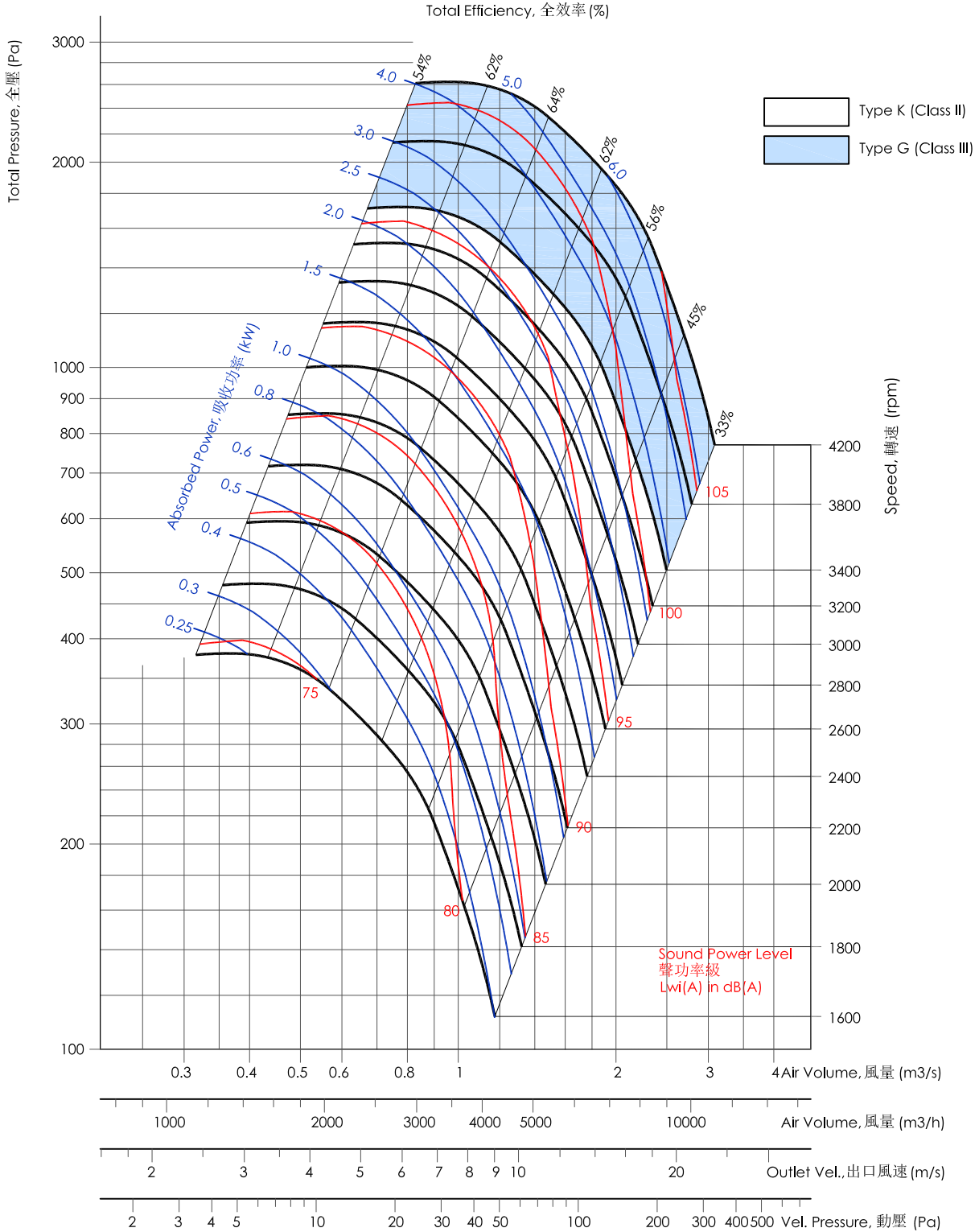

- Performance certified is for installation type B - Free inlet, Ducted outlet. Power rating (kW) does not include transmission losses. Performance ratings do not include the effects of appurtenances (accessories).
- The A-weighted sound ratings shown have been calculated per AMCA International Standard 301. Value shown are for inlet Lw(A) sound power levels for Installation type B - free inlet, ducted outlet.

- 經認證的性能是B類安裝 - 自由入口, 管道出口。功率額定值 (kW) 不包括傳輸(動)損失。各項性能額定值不包括附屬物(附件)的影響。
- 所示A加權聲音性能額定值已按AMCA International標準301計算。所示值為安裝類型 B: 自由入口, 管道出口的聲功率級(入口Lw(A))。



DOUBLE INLET CENTRIFUGAL FANS

CDB 315

WITH BACKWARD CURVED BLADES

Gas Density
氣體密度
1.2 kg/m³

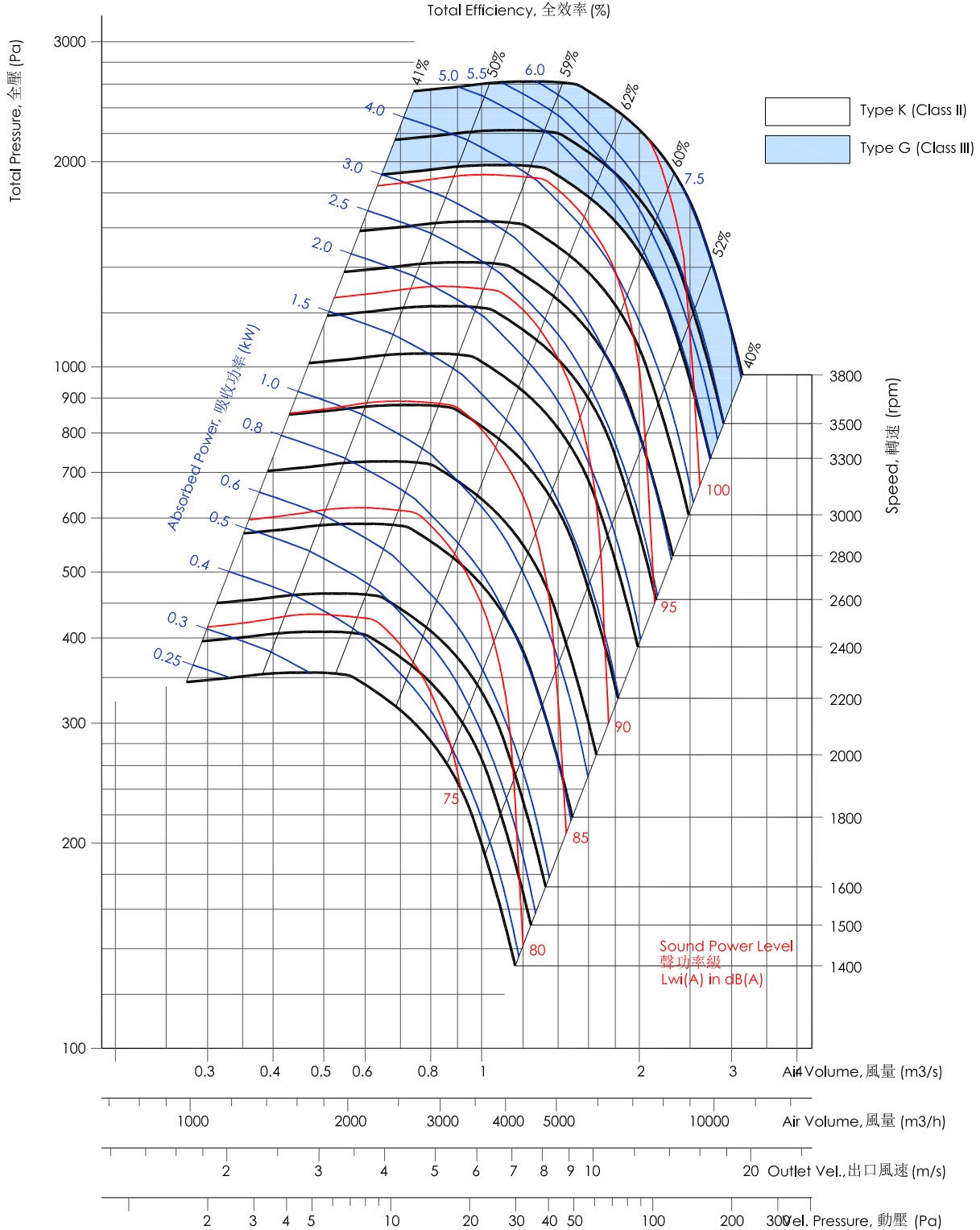

- Performance certified is for installation type B - Free inlet, Ducted outlet. Power rating (kW) does not include transmission losses. Performance ratings do not include the effects of appurtenances (accessories).

- The A-weighted sound ratings shown have been calculated per AMCA International Standard 301. Value shown are for inlet L_{wi} sound power levels for Installation type B - free inlet, ducted outlet.

- 經認證的性能是B類安裝 - 自由入口, 管道出口。功率額定值 (kW) 不包括傳輸(動)損失。各項性能額定值不包括附屬物(附件)的影響。

- 所示A加權聲音性能額定值已按AMCA International標準301計算。所示值為安裝類型 B: 自由入口, 管道出口的聲功率級 (入口L_{wi}(A))。





罡鼎有限公司
CIRCLE & CYCLE LTD

FEG75
Outlet Area =
出口面積
0.205 m²

Fan Performance Curves



DOUBLE INLET CENTRIFUGAL FANS

CDB 355

WITH BACKWARD CURVED BLADES

Gas Density
氣體密度
1.2 kg/m³

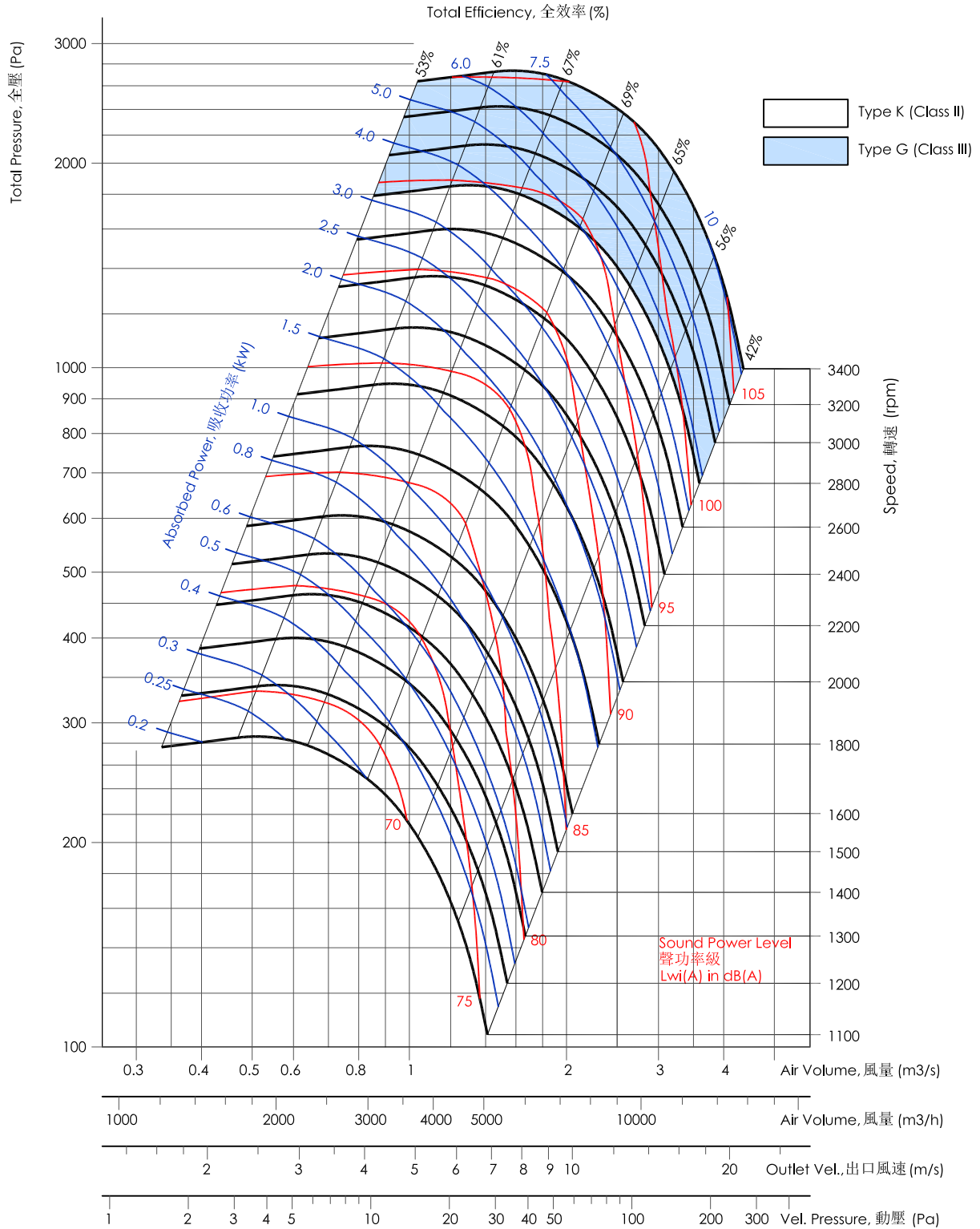

- Performance certified is for installation type B - Free inlet, Ducted outlet. Power rating (kW) does not include transmission losses. Performance ratings do not include the effects of appurtenances (accessories).
- The A-weighted sound ratings shown have been calculated per AMCA International Standard 301. Value shown are for inlet LwiA sound power levels for Installation type B - free inlet, ducted outlet.

- 經認證的性能是B類安裝 - 自由入口, 管道出口。功率額定值 (kW) 不包括傳輸(動)損失。各項性能額定值不包括附屬物(附件)的影響。
- 所示A加權聲音性能額定值已按AMCA International標準301計算。所示值為安裝類型 B; 自由入口, 管道出口的聲功率級(入口LwiA)。

罡鼎有限公司



The characteristics of the machines stated in this catalogue, like dimensions, performances and so on can be modified without prior notice. Copyright Circle & Cycle Ltd - All rights reserved.
本目錄中所述的風機特性, 如尺寸、性能參數等, 可能進行修改, 修改時恕不事先通知。
本本文中所有之各項商標及企業識別圖示, 均為其合法所有人之財產; 未經書面同意, 禁止任何形式之轉載。



DOUBLE INLET CENTRIFUGAL FANS

CDB 400

WITH BACKWARD CURVED BLADES

Gas Density
氣體密度
1.2 kg/m³

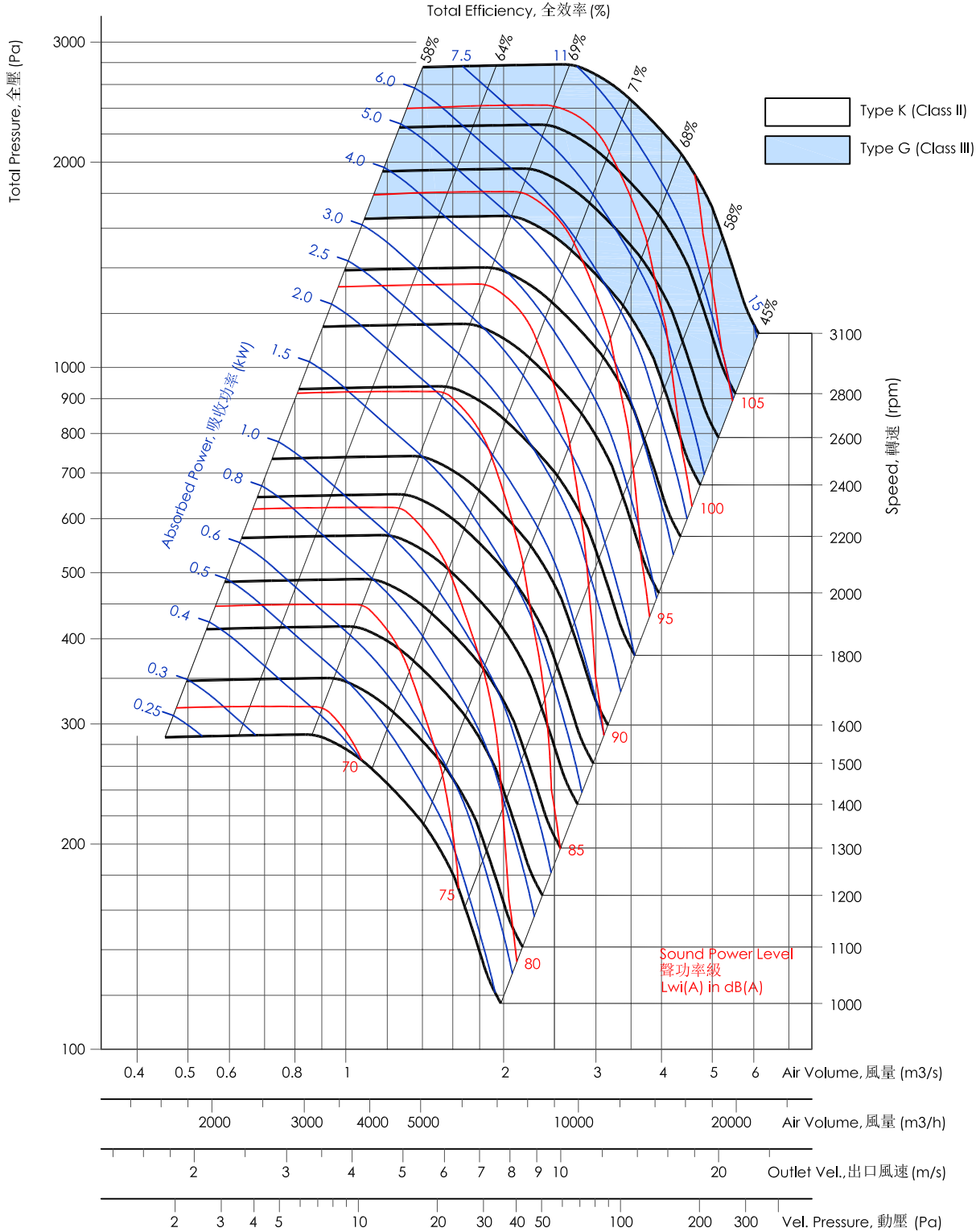

- Performance certified is for installation type B - Free inlet, Ducted outlet. Power rating (kW) does not include transmission losses. Performance ratings do not include the effects of appurtenances (accessories).
- The A-weighted sound ratings shown have been calculated per AMCA International Standard 301. Value shown are for inlet LwiA sound power levels for Installation type B - free inlet, ducted outlet.

- 經認證的性能是B類安裝 - 自由入口, 管道出口。功率額定值 (kW) 不包括傳輸(動)損失。各項性能額定值不包括附屬物(附件)的影響。
- 所示A加權聲音性能額定值已按AMCA International標準301計算。所示值為安裝類型 B: 自由入口, 管道出口的聲功率級(入口LwiA)。





DOUBLE INLET CENTRIFUGAL FANS

CDB 450

WITH BACKWARD CURVED BLADES

Gas Density
氣體密度
1.2 kg/m³

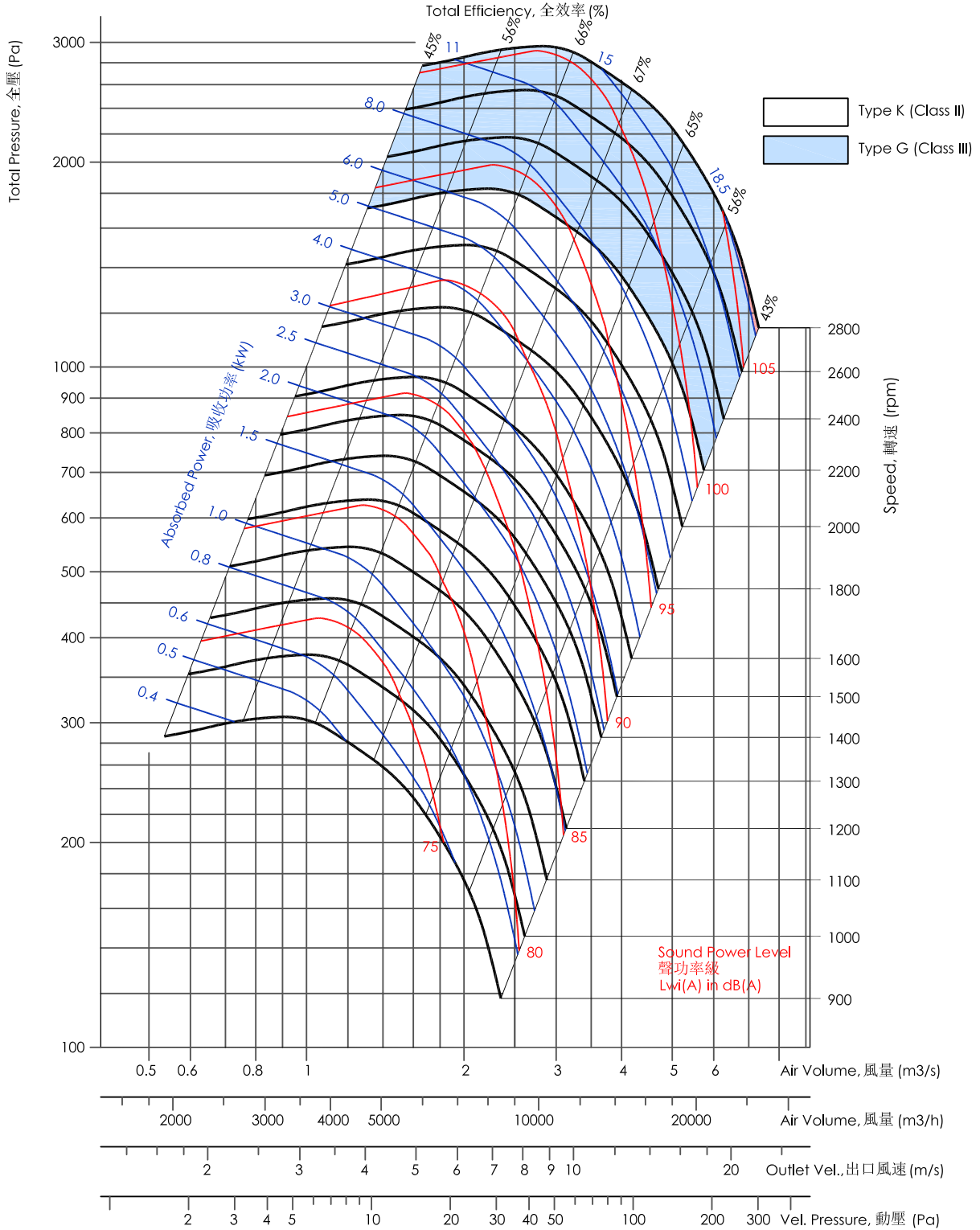

- Performance certified is for installation type B - Free inlet, Ducted outlet. Power rating (kW) does not include transmission losses. Performance ratings do not include the effects of appurtenances (accessories).
- The A-weighted sound ratings shown have been calculated per AMCA International Standard 301. Value shown are for inlet Lw(A) sound power levels for Installation type B - free inlet, ducted outlet.

- 經認證的性能是B類安裝 - 自由入口, 管道出口。功率額定值 (kW) 不包括傳輸(動)損失。各項性能額定值不包括附屬物(附件)的影響。
- 所示A加權聲音性能額定值已按AMCA International標準301計算。所示值為安裝類型 B: 自由入口, 管道出口的聲功率級(入口Lw(A))。

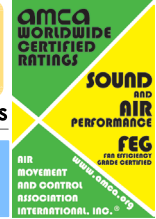

DOUBLE INLET CENTRIFUGAL FANS

CDB 500

WITH BACKWARD CURVED BLADES

Gas Density
氣體密度
1.2 kg/m³

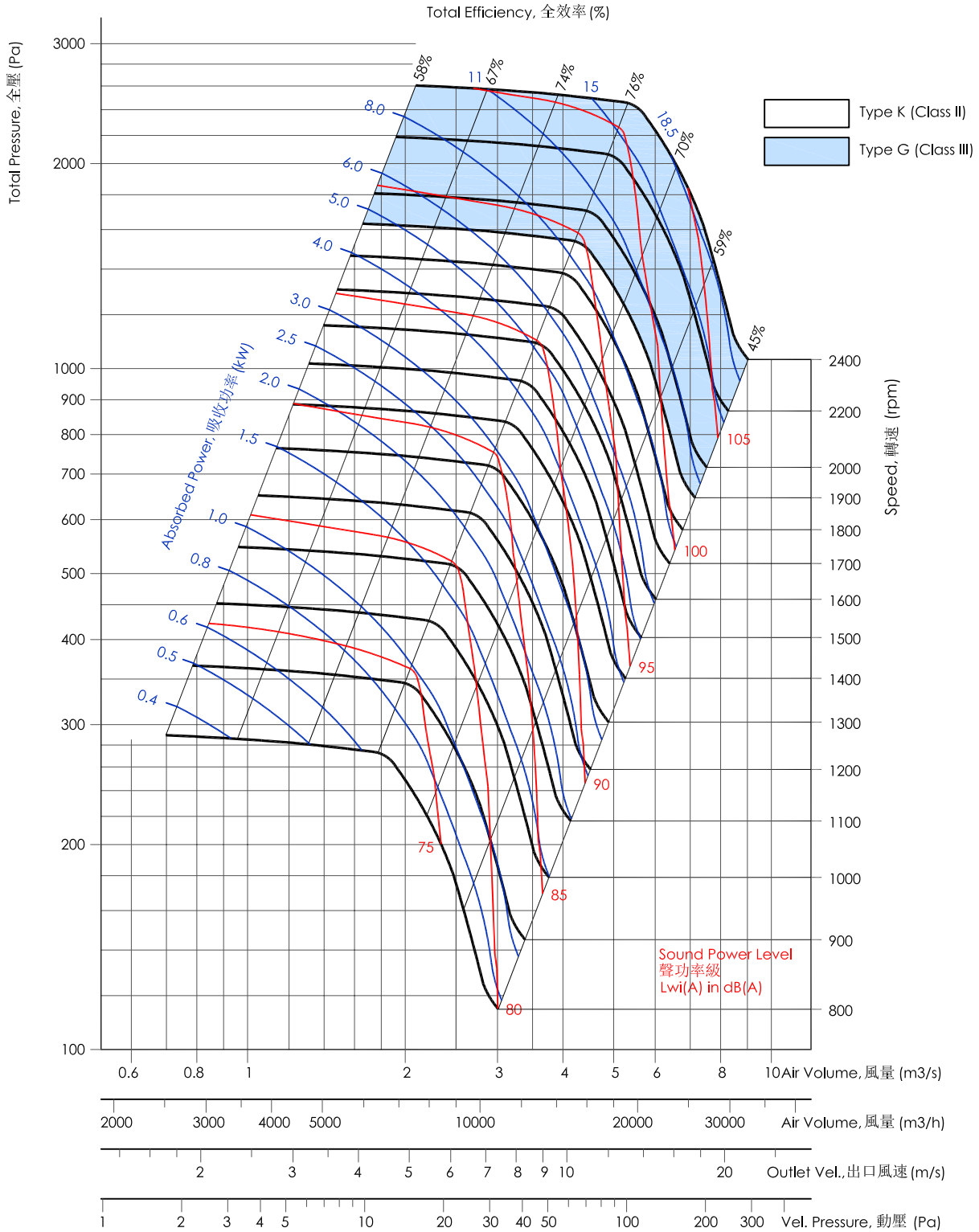

- Performance certified is for installation type B - Free inlet, Ducted outlet. Power rating (kW) does not include transmission losses. Performance ratings do not include the effects of appurtenances (accessories).
- The A-weighted sound ratings shown have been calculated per AMCA International Standard 301. Value shown are for inlet LwiA sound power levels for Installation type B - free inlet, ducted outlet.

- 經認證的性能是B類安裝 - 自由入口, 管道出口。功率額定值 (kW) 不包括傳輸(動)損失。各項性能額定值不包括附屬物(附件)的影響。
- 所示A加權聲音性能額定值已按AMCA International標準301計算。所示值為安裝類型 B: 自由入口, 管道出口的聲功率級(入口LwiA)。





DOUBLE INLET CENTRIFUGAL FANS

CDB 560

WITH BACKWARD CURVED BLADES

Gas Density
氣體密度
1.2 kg/m³

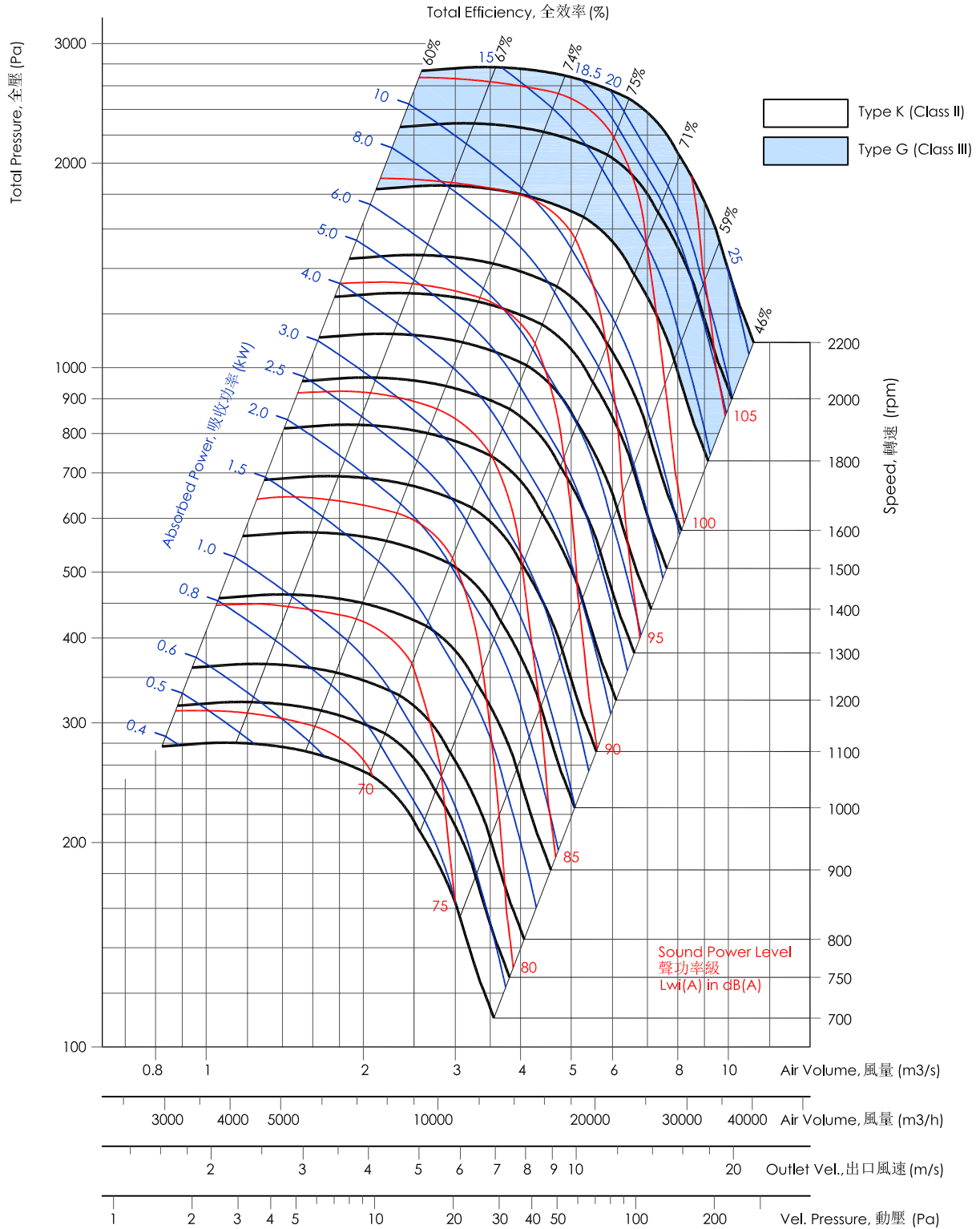

- Performance certified is for installation type B - Free inlet, Ducted outlet. Power rating (kW) does not include transmission losses. Performance ratings do not include the effects of appurtenances (accessories).
- The A-weighted sound ratings shown have been calculated per AMCA International Standard 301. Value shown are for inlet Lw(A) sound power levels for Installation type B - free inlet, ducted outlet.

- 經認證的性能是B類安裝 - 自由入口, 管道出口。功率額定值 (kW) 不包括傳輸(動)損失。各項性能額定值不包括附屬物(附件)的影響。
- 所示A加權聲音性能額定值已按AMCA International標準301計算。所示值為安裝類型 B; 自由入口, 管道出口的聲功率級(入口Lw(A))。





DOUBLE INLET CENTRIFUGAL FANS

CDB 630

WITH BACKWARD CURVED BLADES

Gas Density
氣體密度
1.2 kg/m³

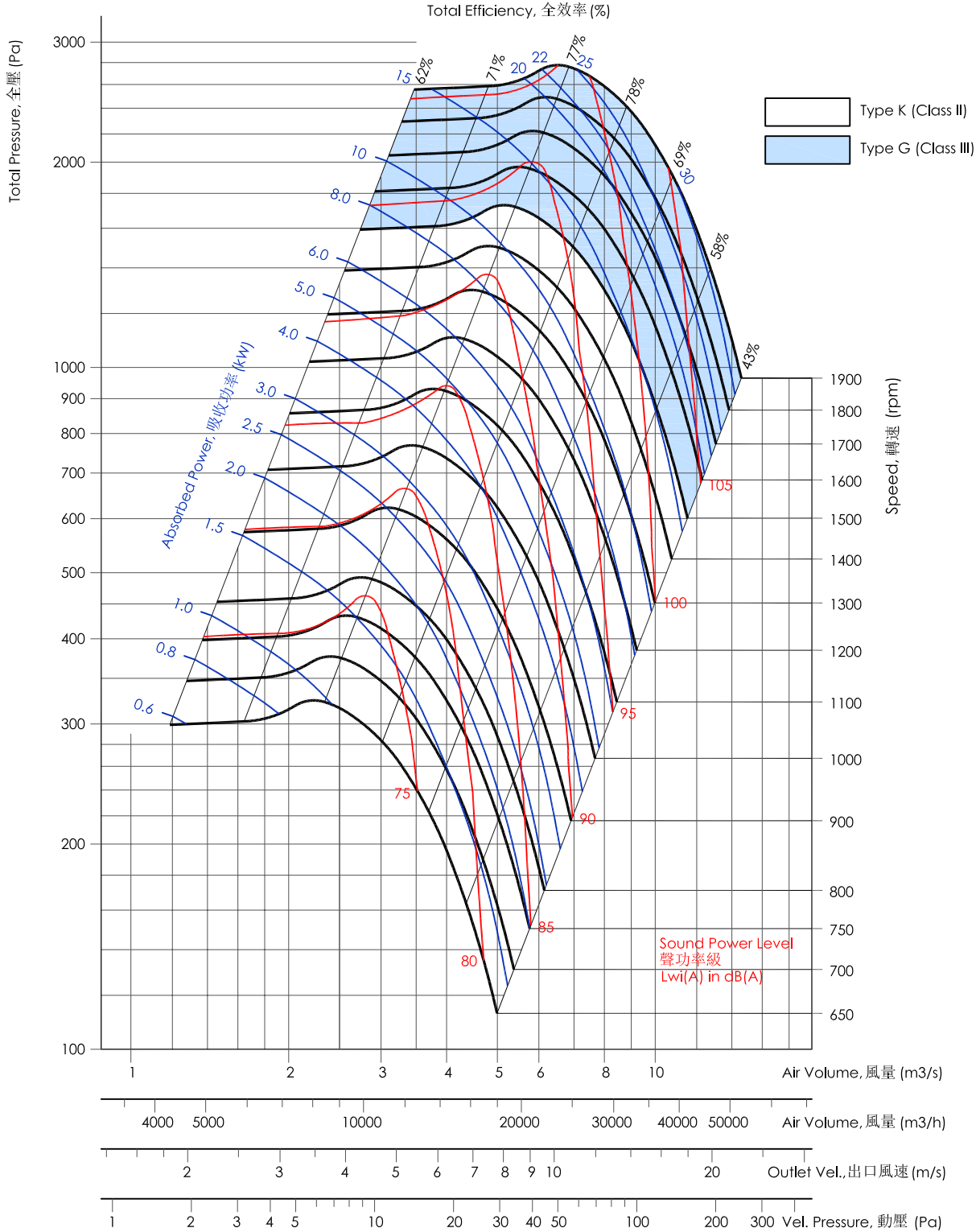

- Performance certified is for installation type B - Free inlet, Ducted outlet. Power rating (kW) does not include transmission losses. Performance ratings do not include the effects of appurtenances (accessories).
- The A-weighted sound ratings shown have been calculated per AMCA International Standard 301. Value shown are for inlet L_{wi}(A) sound power levels for Installation type B - free inlet, ducted outlet.

- 經認證的性能是B類安裝 - 自由入口, 管道出口。功率額定值 (kW) 不包括傳輸(動)損失。各項性能額定值不包括附屬物(附件)的影響。
- 所示A加權聲音性能額定值已按AMCA International標準301計算。所示值為安裝類型 B: 自由入口, 管道出口的聲功率級(入口L_{wi}(A))。





DOUBLE INLET CENTRIFUGAL FANS **CDB 710**

WITH BACKWARD CURVED BLADES

Gas Density
氣體密度
1.2 kg/m³

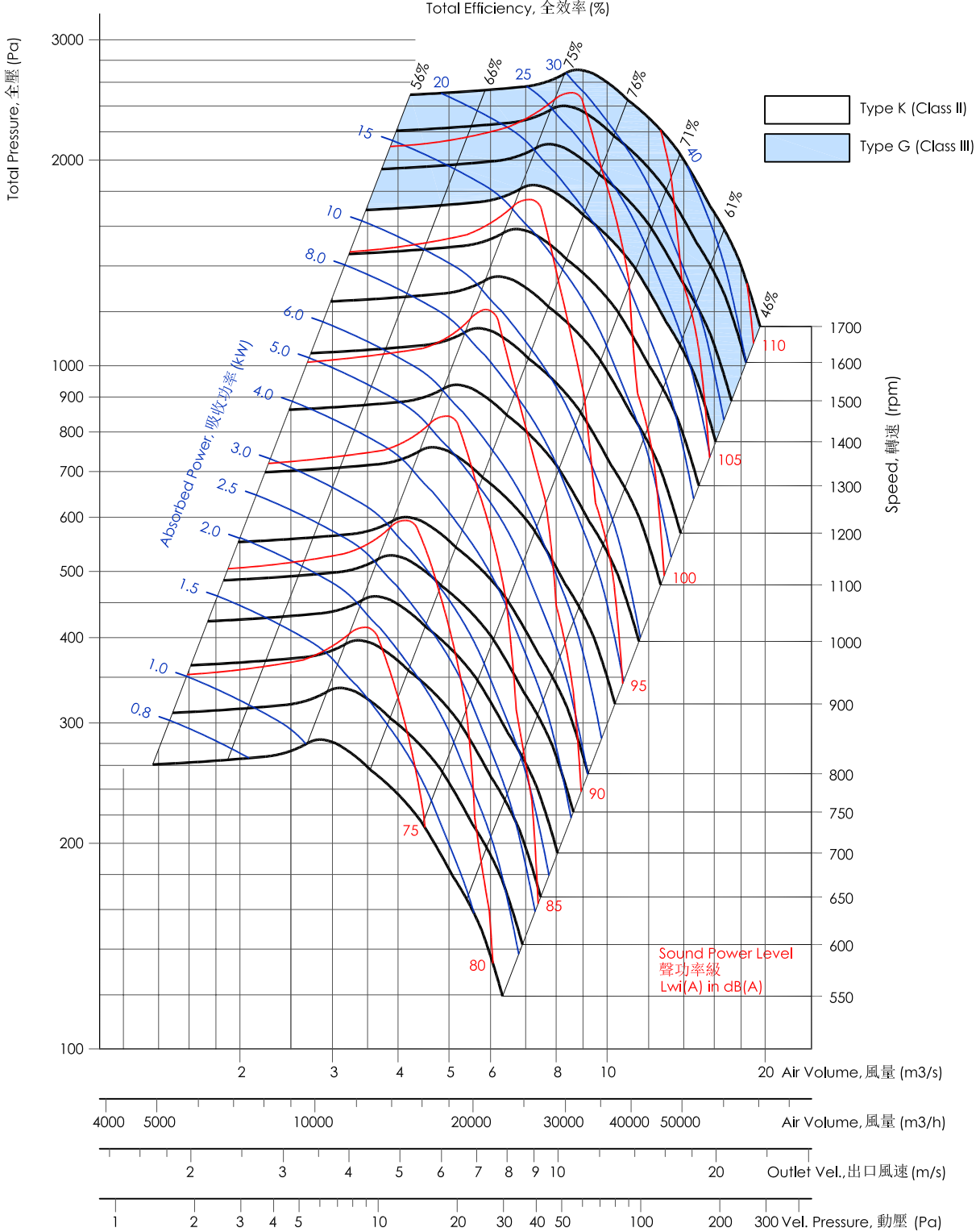

- Performance certified is for installation type B - Free inlet, Ducted outlet. Power rating (kW) does not include transmission losses. Performance ratings do not include the effects of appurtenances (accessories).
- The A-weighted sound ratings shown have been calculated per AMCA International Standard 301. Value shown are for inlet Lw(A) sound power levels for Installation type B - free inlet, ducted outlet.
- 經認證的性能是B類安裝 - 自由入口, 管道出口。功率額定值 (kW) 不包括傳輪(動)損失。各項性能額定值不包括附屬物(附件)的影響。
- 所示A加權聲音性能額定值已按AMCA International標準301計算。所示值為安裝類型 B: 自由入口, 管道出口的聲功率級(入口Lw(A))。





DOUBLE INLET CENTRIFUGAL FANS

CDB 800

WITH BACKWARD CURVED BLADES

Gas Density
氣體密度
1.2 kg/m³

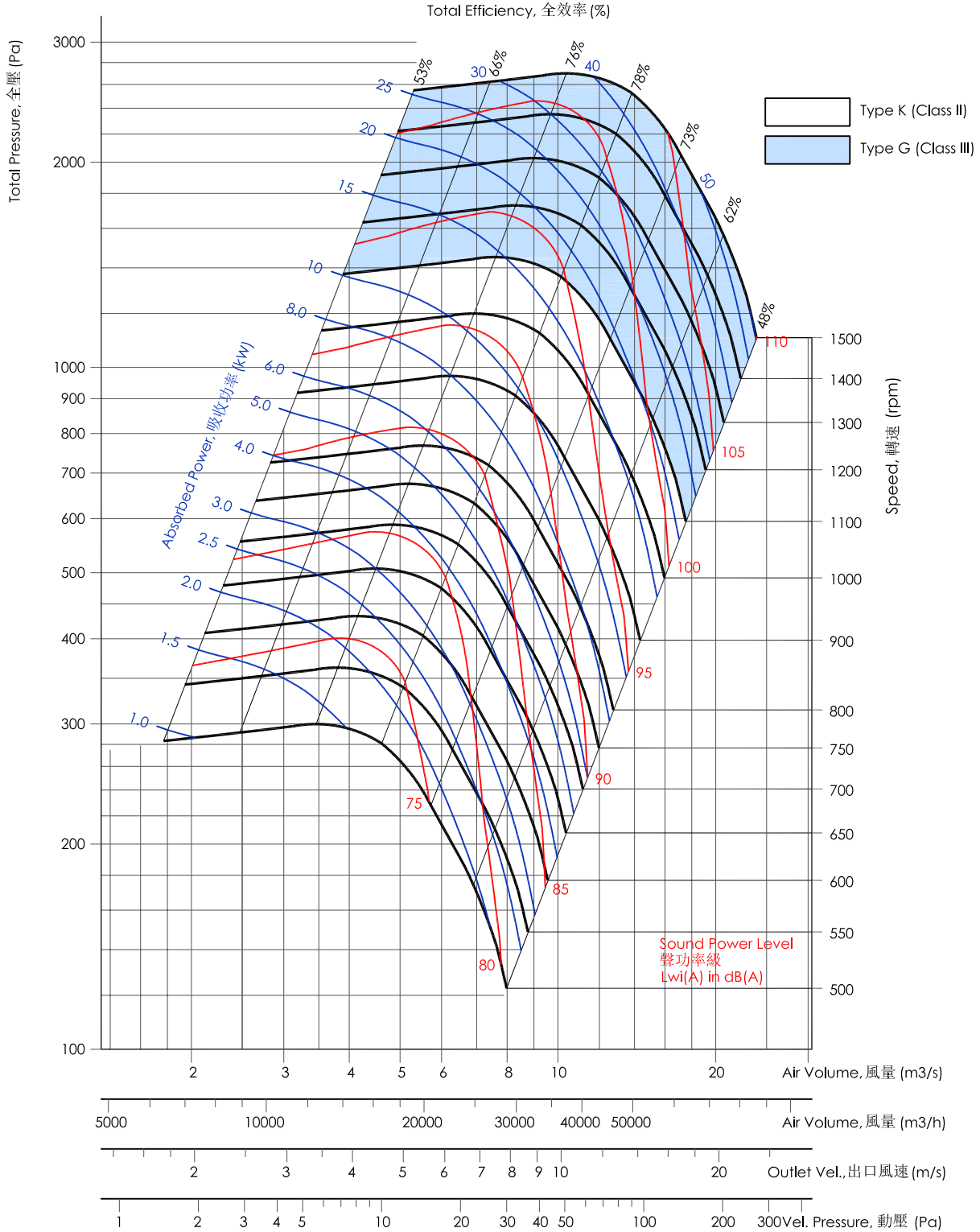

- Performance certified is for installation type B - Free inlet, Ducted outlet. Power rating (kW) does not include transmission losses. Performance ratings do not include the effects of appurtenances (accessories).
- The A-weighted sound ratings shown have been calculated per AMCA International Standard 301. Value shown are for inlet Lw(A) sound power levels for Installation type B - free inlet, ducted outlet.

- 經認證的性能是B類安裝 - 自由入口, 管道出口。功率額定值 (kW) 不包括傳輸(動)損失。各項性能額定值不包括附屬物(附件)的影響。
- 所示A加權聲音性能額定值已按AMCA International標準301計算。所示值為安裝類型 B: 自由入口, 管道出口的聲功率級(入口Lw(A))。





DOUBLE INLET CENTRIFUGAL FANS

CDB 900

WITH BACKWARD CURVED BLADES

Gas Density
氣體密度
1.2 kg/m³

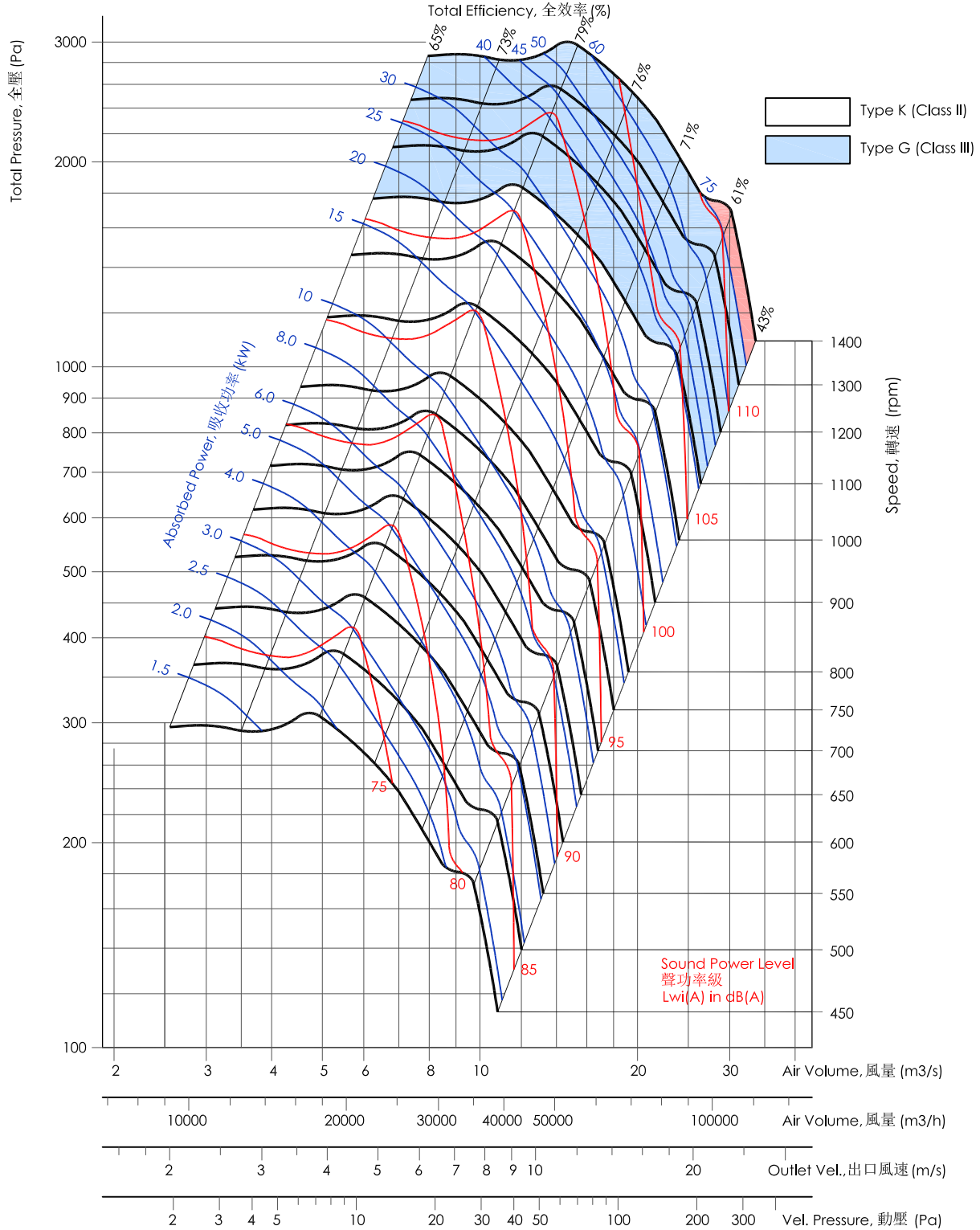

- Performance certified is for installation type B - Free inlet, Ducted outlet. Power rating (kW) does not include transmission losses. Performance ratings do not include the effects of appurtenances (accessories).
- The A-weighted sound ratings shown have been calculated per AMCA International Standard 301. Value shown are for inlet LwiA sound power levels for Installation type B - free inlet, ducted outlet.

- 經認證的性能是B類安裝 - 自由入口, 管道出口。功率額定值 (kW) 不包括傳輸(動)損失。各項性能額定值不包括附屬物(附件)的影響。
- 所示A加權聲音性能額定值已按AMCA International標準301計算。所示值為安裝類型 B: 自由入口, 管道出口的聲功率級(入口LwiA)。

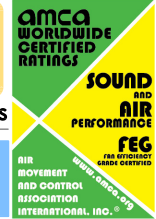

DOUBLE INLET CENTRIFUGAL FANS

CDB 1000

WITH BACKWARD CURVED BLADES

Gas Density
氣體密度
1.2 kg/m³

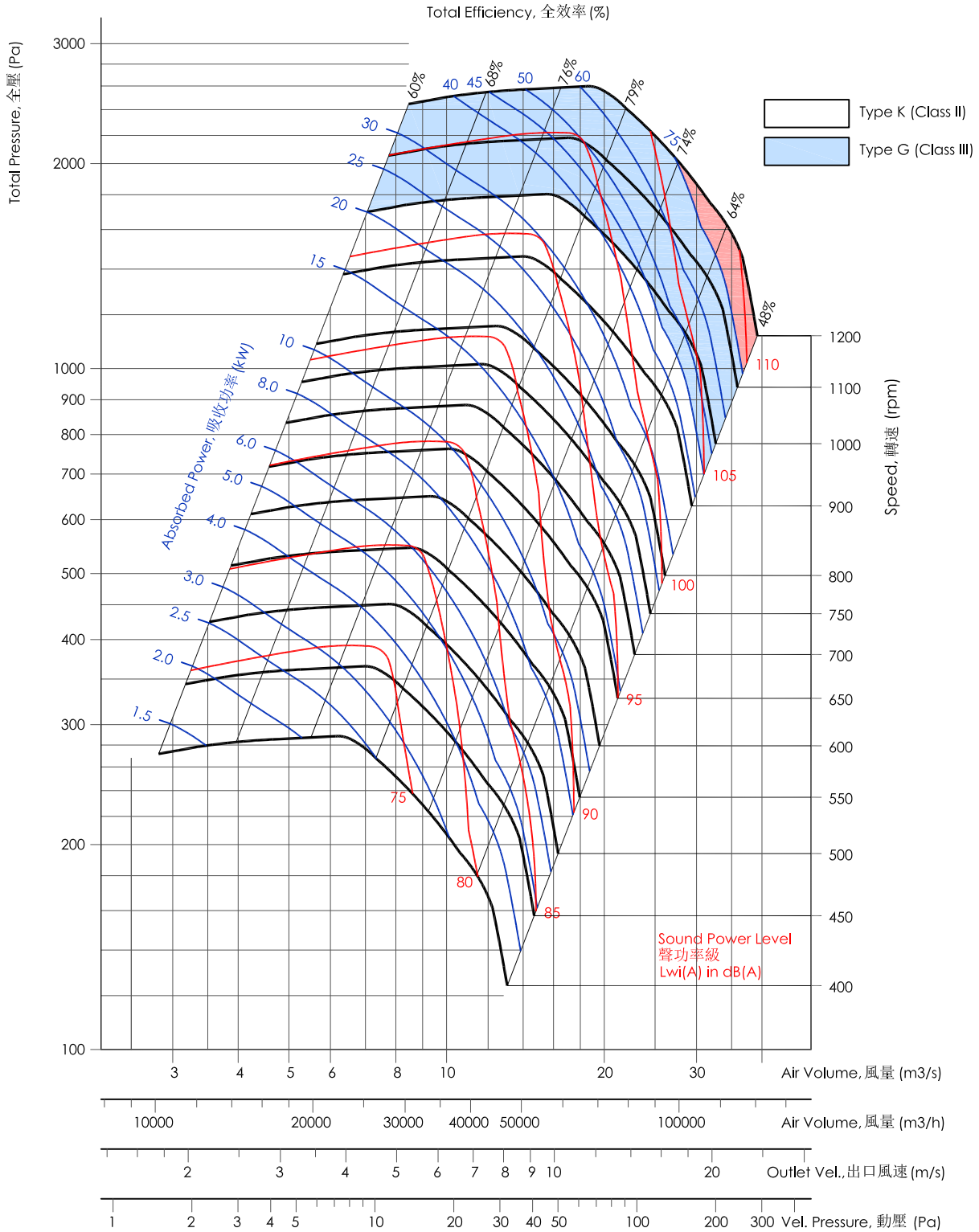

- Performance certified is for installation type B - Free inlet, Ducted outlet. Power rating (kW) does not include transmission losses. Performance ratings do not include the effects of appurtenances (accessories).
- The A-weighted sound ratings shown have been calculated per AMCA International Standard 301. Value shown are for inlet LwiA sound power levels for Installation type B - free inlet, ducted outlet.

- 經認證的性能是B類安裝 - 自由入口, 管道出口。功率額定值 (kW) 不包括傳輸(動)損失。各項性能額定值不包括附屬物(附件)的影響。
- 所示A加權聲音性能額定值已按AMCA International標準301計算。所示值為安裝類型 B: 自由入口, 管道出口的聲功率級(入口LwiA)。



CIRCLE & CYCLE CDB Series Centrifugal Fan

CDB -250K ~ 1000K 風機外型尺寸 Dimensions of CDB -250K ~ 1000K Fans

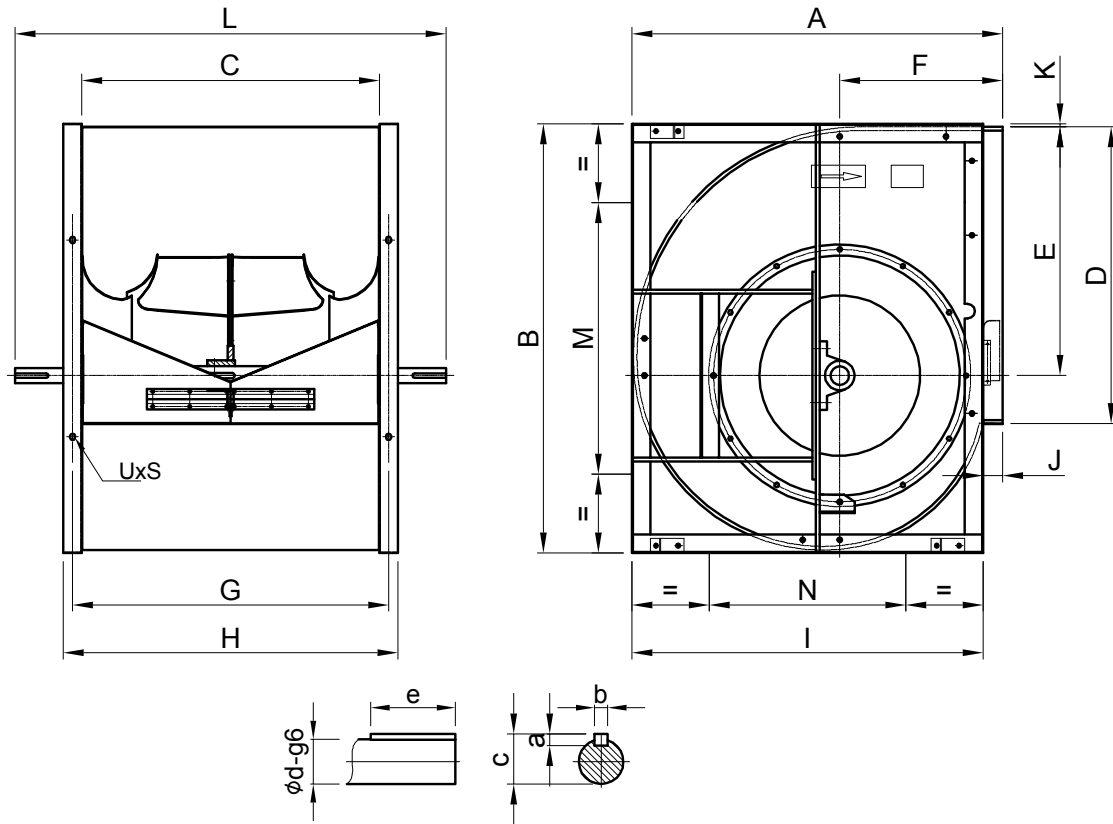

風機規格 Fan Model	A	B	C	D	E	F	G	H	I	J	K	L	M	N	a	b	c	d	e	UxS
CDB250K	427.5	475	322	322	264	193	350	372	391.5	36	10.5	520	224	224	6	6	6	20	45	11×16
CDB280K	476.5	530	361	361	296	213	391	421	440.5	36	11.5	580	280	280	7	8	8	25	50	11×16
CDB315K	530	595	404	404	336	234	434	464	492	38	11.5	625	280	280	7	8	8	25	50	11×16
CDB355K	587.5	663	453	453	376	260	489	513	550.5	37	12	680	355	355	7	8	8	30	65	11×16
CDB400K	656	742	507	507	421.5	292	547	587	620	36	12	760	355	355	7	8	8	30	65	11×16
CDB450K	739	841	569	569	482	325	609	649	699	40	12	845	530	530	8	10	10	35	75	11×16
CDB500K	810	929	638	638	530	352	678	718	762	48	12	920	530	530	8	10	10	35	75	13×18
CDB560K	890	1022	715	715	599	390	765	805	841	49	5	1060	530	530	8	12	12	40	75	13×18
CDB630K	998	1156	801	801	670	438	851	901	946	52	8	1160	530	530	8	12	12	40	90	13×18
CDB710K	1122	1298	898	898	761.5	482	948	998	1062	60	6.5	1300	630	630	9	14	14	50	110	17×22
CDB800K	1254	1466	1007	1007	855.5	538	1057	1107	1188	66	6.5	1450	710	710	9	14	14	50	110	17×22
CDB900K	1406	1641	1130	1130	962.5	600	1180	1230	1328	78	6.5	1580	800	800	11	18	18	60	110	17×22
CDB1000K	1538	1798	1267	1267	1052	655	1317	1367	1454	84	8	1700	900	900	11	18	18	60	110	17×22

昱鼎有限公司



The characteristics of the machines stated in this catalogue, like dimensions, performances and so on can be modified without prior notice. Copyright Circle & Cycle Ltd - All rights reserved.
本目錄中所述的風機特性, 如尺寸、性能參數等, 可能進行修改, 修改時恕不事先通知。
本本文中所有之各項商標及企業識別圖示, 均為其合法所有人之財產, 未經書面同意, 禁止任何形式之轉載。

CDB 罌鼎雙吸後傾式風機

CDB -250G ~ 1000G 風機外型尺寸 Dimensions of CDB -250G ~ 1000G Fans

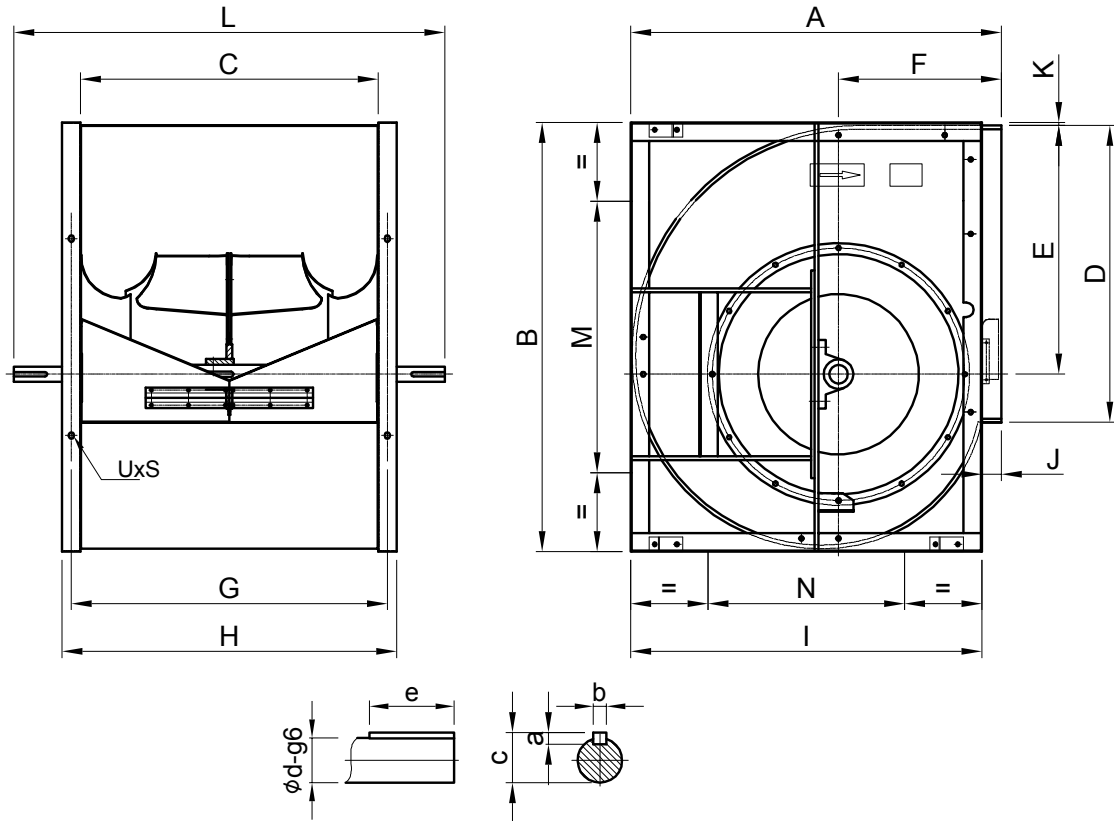

風機規格 Fan Model	A	B	C	D	E	F	G	H	I	J	K	L	M	N	a	b	c	d	e	UxS
CDB250G	427.5	475	322	322	264	193	350	372	391.5	36	10.5	520	224	224	7	8	28	25	45	11x16
CDB280G	476.5	530	361	361	296	213	391	421	440.5	36	11.5	580	280	280	7	8	33	30	50	11x16
CDB315G	530	595	404	404	336	234	434	464	492	38	11.5	625	280	280	7	8	33	30	50	11x16
CDB355G	587.5	663	453	453	376	260	489	513	550.5	37	12	680	355	355	8	10	38	35	65	11x16
CDB400G	656	742	507	507	421.5	292	547	587	620	36	12	760	355	355	8	10	38	35	65	11x16
CDB450G	739	841	569	569	482	325	609	649	699	40	12	845	530	530	8	12	43	40	75	11x16
CDB500G	810	929	638	638	530	352	678	718	762	48	12	920	530	530	8	12	43	40	75	13x18
CDB560G	890	1022	715	715	599	390	765	805	841	49	5	1060	530	530	9	14	53.8	50	90	13x18
CDB630G	998	1156	801	801	670	438	851	901	946	52	8	1160	530	530	9	14	53.8	50	90	13x18
CDB710G	1122	1298	898	898	761.5	482	948	998	1062	60	6.5	1300	630	630	11	18	64.4	60	110	17x22
CDB800G	1254	1466	1007	1007	855.5	538	1057	1107	1188	66	6.5	1450	710	710	11	18	64.4	60	110	17x22
CDB900G	1406	1641	1130	1130	962.5	600	1180	1230	1328	78	6.5	1580	800	800	12	20	69.5	65	110	17x22
CDB1000G	1538	1798	1267	1267	1052	655	1317	1367	1454	84	8	1700	900	900	12	20	69.5	65	110	17x22

罌鼎有限公司



The characteristics of the machines stated in this catalogue, like dimensions, performances and so on can be modified without prior notice. Copyright Circle & Cycle Ltd - All rights reserved.
本目錄中所述的風機特性, 如尺寸、性能參數等, 可能進行修改, 修改時恕不事先通知。
本本文中所使用之各項商標及企業識別圖示, 均為其合法所有人之財產; 未經書面同意, 禁止任何形式之轉載。

CIRCLE & CYCLE CDB Series Centrifugal Fan

		250	280	315	355	400	450	500	560	630	710	800	900	1000
	K	3	4	5.5	7.5	7.5	11	11	18.5	22	30	30	45	45
最大選配功率 Max.installed power (kW)	G	5.5	7.5	7.5	11	15	18.5	22	30	37	55	55	75	75
最大工作轉速 Max.speed (r/min)	K	3800	3400	3300	2800	2400	2200	1900	1800	1500	1400	1100	1100	1100
	G	4500	4200	3800	3400	3100	2800	2400	2200	1900	1700	1500	1400	1200
風機重量 Fan weight (kg)	K	16	22	30	40	55	74	89	162	196	260	325	410	530
	G	16.5	22.5	31	42	57	76	92	168	204	268	334	420	540
空氣溫度 (最低 -20°C) Air temperature (min-20°C)	K	85	85	85	85	85	85	85	85	85	85	85	85	85
	G	85	85	85	85	85	85	85	85	85	85	85	85	85
軸承額定動載荷 Bearing Dynamic Load(N)	K	12800	14000	14000	19500	19500	25700	29100	32500	32500	43500	43500	57500	57500
	G	14000	19500	19500	25700	25700	29100	32500	43500	43500	57500	57500	66000	66000
軸承型號 Bearing number	K	UCP204	UCP205	UCP205	UCP206	UCP206	UCP207	UCP208	UKP209	UKP209	UKP211	UKP211	UKP213	UKP213
	G	CUP205	UCP206	UCP206	UCP207	UCP207	UCP208	UKP209	UKP211	UKP211	UKP213	UKP213	UKP215	UKP215

NOTES

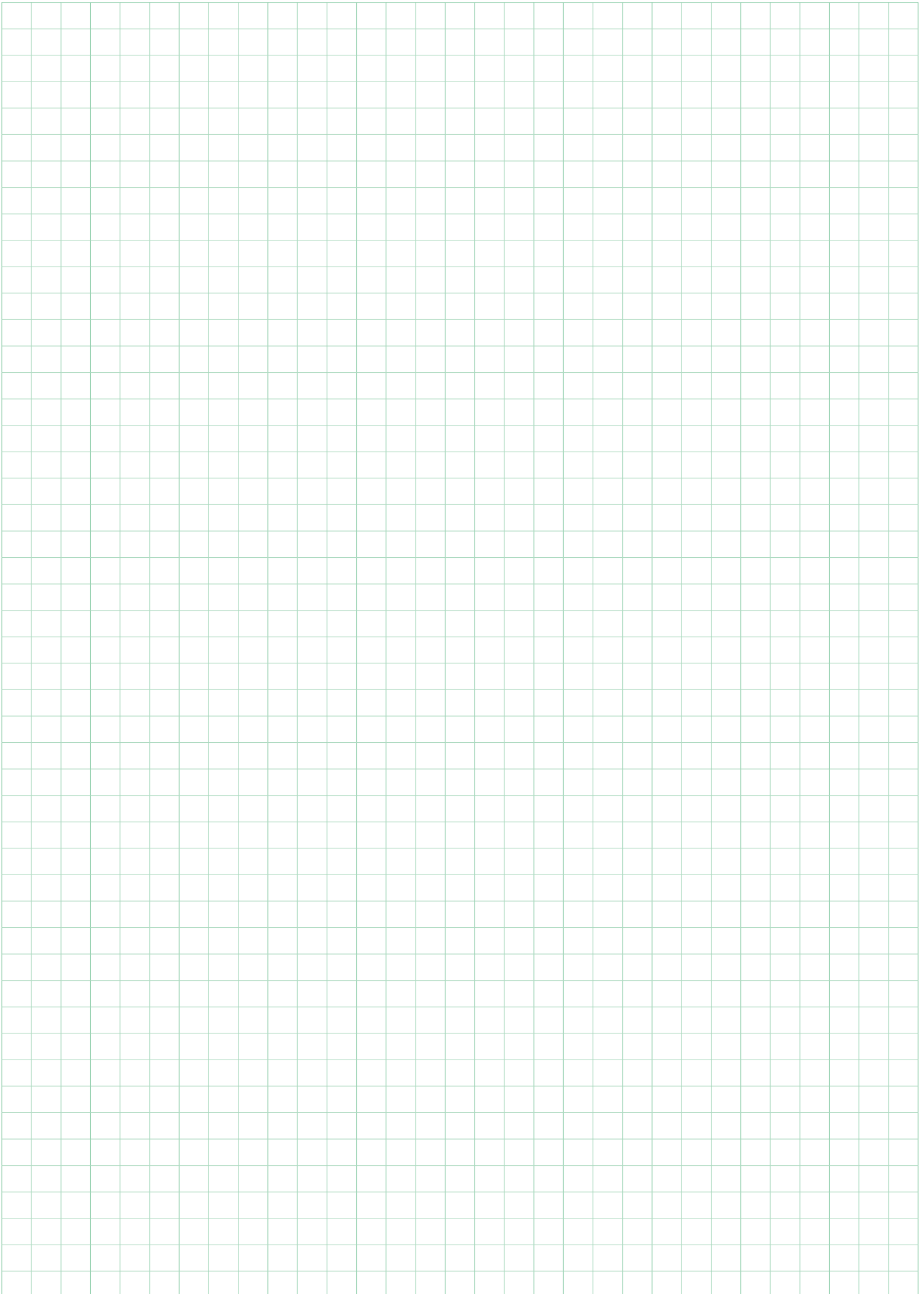

C No. : GT-004-C March / 2020
型錄編號 : GT-004-C 2020 / 三月

The characteristics of the machines stated in this catalogue, like dimensions, performances and so on, can be modified without previous notice.
Copyright Circle & Cycle Ltd - All rights reserved.

本目錄中所述的風機特性，如尺寸、性能參數等，可能進行修改，修改時恕不事先通知。
本文中所使用之各項商標及企業識別圖示，均為其合法所有人之財產；未經書面同意，禁止任何形式之轉載。



罡鼎有限公司 CIRCLE & CYCLE LTD.

台北事務所：10665 臺北市大安區復興南路1段293號3樓之1
3F.-1, NO.293, SEC. 1, FUXING S. RD., DA-AN DIST., TAIPEI CITY
10665, TAIWAN (R.O.C.)
TEL : 03-9895881
URL : www.ccfan.com.tw
E-mail : 9895881@gmail.com

罡鼎一廠：26641 宜蘭縣三星鄉集慶村集賢一路38號
No.38, Ji-Sian 1 Rd., Jiqing Village San-Sing Township,
Yi-Lan County 26641, Taiwan
TEL : 03-9895881 FAX : 03-9895311

罡鼎二廠：宜蘭縣三星鄉大隱村大埔中路233巷51弄3號
C&C 2nd Factory : No.3, Aly. 51, Ln. 233, Dapu Central Rd., Dayin Vil.,
Sanxing Township, Yilan County 26644, Taiwan
TEL : 03-9898885 FAX : 03-9898665