

ELF6425DD CONTINUOUS DRAINABLE STATIONARY LOUVER EXTRUDED ALUMINUM

STANDARD CONSTRUCTION

FRAME

6" (125) deep, 6063T5 extruded aluminum with .081" (2.1) nominal wall thickness. Downspouts and caulking surfaces provided.

BLADES

6063T5 extruded aluminum with .081" (2.1) nominal wall thickness. Double drainable blades positioned at 42¹/₂° angle and spaced at approximately 5" (127) center to center.

SCREEN

3/4" x .051" (19 x 1.3) expanded, flattened aluminum bird screen in removable frame. Screen adds approximately 1/2" (13) to louver depth.

FINISH

Mill.

MINIMUM SIZE

12"w x 12"h (305 x 305).

APPROXIMATE SHIPPING WEIGHT

8 lbs. per sq. ft. (39.1 per m²).

MAXIMUM FACTORY ASSEMBLY SIZE

Shall be 60 sq. ft. (6m²) per section, not to exceed 120"w x 90"h (3048 x 2286) or 90"w x 120"h (2286 x 3048).

Louvers larger than the maximum factory assembly size will require field assembly of smaller sections.

SUPPORTS

Louvers may be provided with rear mounted blade supports that increase overall louver depth depending on louver size, assembly configuration or windload.

Consult Ruskin for additional information.

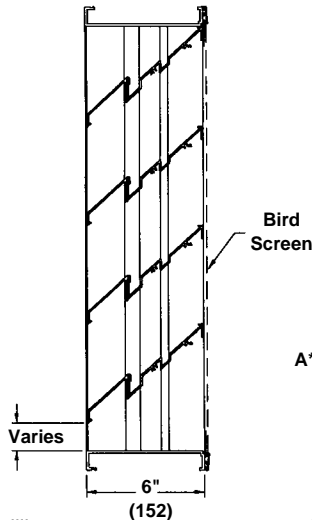
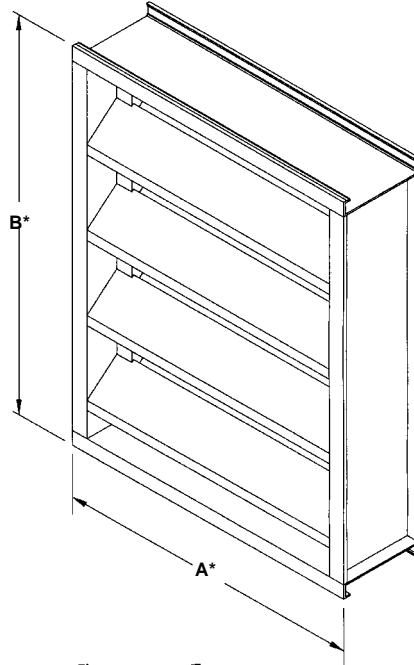

FEATURES

The ELF6425DD offers:

- Drainable louver performance with continuous blade construction.
- Recessed vertical drain mullions that do not interrupt exterior blade appearance.
- Drainable blades with recessed gutters for collection and removal of rain and a smooth exterior surface providing a clean, architectural look.
- 51% free area, beginning water penetration at 852 fpm free area velocity with .09" (2.29) pressure drop.
- AMCA licensed performance.
- Extruded aluminum construction for low maintenance and high resistance to corrosion.

VARIATIONS

Variations to the basic design of the louver are available at additional cost. They include:

- Extended sill.
- Hinged frame.
- Front or rear security bars.
- Filter racks.
- A variety of bird and insect screens.
- Selection of finishes: prime coat, baked enamel (modified fluoropolymer), epoxy, Acrodize, Kynar, clear and color anodize. (Some variation in anodize color consistency is possible.)

Consult Ruskin for other special requirements.

FRAME CONSTRUCTION

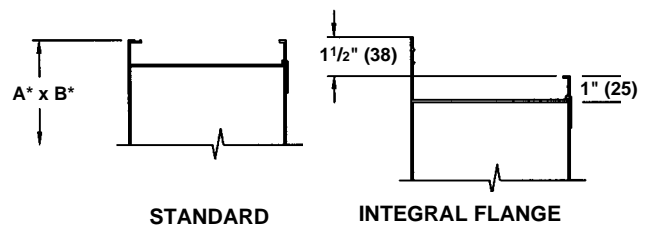

Dimensions in inches, parenthesis () indicate millimeters.

*Units furnished 1/4" (6) smaller than given opening dimensions.

TAG	QTY.	SIZE		FRAME	VARIATIONS
		A*-WIDE	B*-HIGH		
PROJECT ARCH./ENGR. REPRESENTATIVE				LOCATION CONTRACTOR DATE	

SUGGESTED SPECIFICATION

Furnish and install louvers as hereinafter specified where shown on plans or as described in schedules. Louvers shall be stationary type with downspouts in jambs and mullions. Louvers shall have a minimum of 50% free area based on a 48" w x 48" h (1219 x 1219) size. Stationary blades shall be contained within a 6" (152) frame. Louver components (heads, jambs, sills, blades & mullions) shall be factory assembled by the louver manufacturer. Louver sizes too large for shipping shall be built up by the contractor from factory assembled louver sections to provide overall sizes required. Louver design shall incorporate structural supports required to withstand a wind load of 20 lbs. per sq. ft. (.96kPa) (equivalent of a 90 mph wind [145 KPH] - specifier may substitute any loading required).

Louvers shall be Ruskin Model ELF6425DD.

Frame: 6" (152) deep, .081" (2.1) wall thickness.

Blades: .081" (2.1) wall thickness at 42¹/₂° angle and spaced approximately 5" (127) centers.

Screen: 3/4" x .051" (19 x 1.3) expanded, flattened aluminum in removable frame.

Finish: Select finish specification from Ruskin Finishes Brochure.

Published louver performance data bearing the AMCA Certified Ratings Seal for Air Performance & Water Penetration must be submitted for approval prior to fabrication and must demonstrate pressure drop and water penetration equal to or less than the Ruskin model specified.

PERFORMANCE DATA

AMCA Standard 500 provides a reasonable basis for testing and rating louvers. Testing to AMCA 500 is performed under a certain set of laboratory conditions. This does not guarantee that other conditions will not occur in the actual environment where louvers must operate. The louver system should be designed with a rea-

sonable safety factor for louver performance. To ensure protection from water carryover, design with a performance level somewhat below maximum desired pressure drop and .01 oz./sq. ft. of water penetration.

WATER PENETRATION

Test size 48" wide x 48" high (1219 x 1219)

Beginning point of water penetration at .01 oz./sq. ft. is 852 fpm (260 m/min).

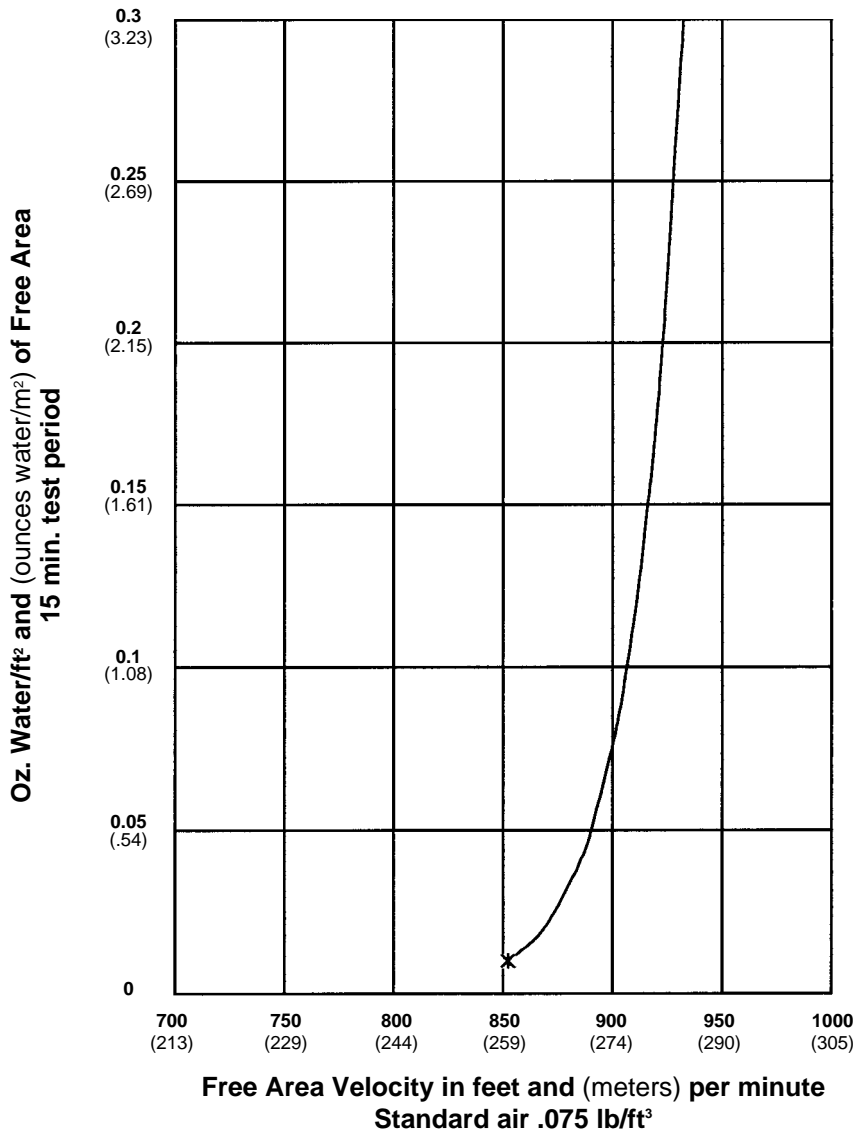

Ruskin Manufacturing Company certifies that the ELF6425DD louvers shown herein are licensed to bear the AMCA Seal. The ratings shown are based on tests and procedures performed in accordance with AMCA Publication 511 and comply with the requirements of the AMCA Certified Ratings Program. The AMCA Certified Ratings Seal applies to air performance ratings and water penetration ratings only.

FREE AREA GUIDE

Free Area Guide shows free area in ft² and m² for various sizes of ELF6425DD.

Width – Inches and Meters

Height – Inches and Meters	12	18	24	30	36	42	48	54	60	66	72	78	84	90	96	102	108	114	120
	0.30	0.46	0.61	0.76	0.91	1.07	1.22	1.37	1.52	1.68	1.83	1.98	2.13	2.29	2.44	2.59	2.74	2.90	3.05
12 0.30	0.26 0.02	0.46 0.04	0.67 0.06	0.87 0.08	1.07 0.10	1.27 0.12	1.47 0.14	1.68 0.16	1.88 0.17	2.08 0.19	2.28 0.21	2.48 0.23	2.69 0.25	2.89 0.27	3.09 0.29	3.29 0.31	3.49 0.32	3.70 0.34	3.90 0.36
18 0.46	0.40 0.04	0.71 0.07	1.01 0.09	1.32 0.12	1.63 0.15	1.94 0.18	2.24 0.21	2.55 0.24	2.86 0.27	3.17 0.29	3.48 0.32	3.78 0.35	4.09 0.38	4.40 0.41	4.71 0.44	5.02 0.47	5.32 0.50	5.63 0.52	5.94 0.55
24 0.61	0.63 0.06	1.11 0.10	1.60 0.15	2.08 0.19	2.57 0.24	3.06 0.28	3.54 0.33	4.03 0.37	4.51 0.42	5.00 0.46	5.49 0.51	5.97 0.56	6.46 0.60	6.94 0.65	7.43 0.69	7.91 0.74	8.40 0.78	8.89 0.83	9.37 0.87
30 0.76	0.86 0.08	1.52 0.14	2.18 0.20	2.85 0.24	3.51 0.33	4.18 0.39	4.84 0.45	5.50 0.51	6.17 0.57	6.83 0.64	7.49 0.70	8.16 0.76	8.82 0.82	9.49 0.88	10.15 0.94	10.81 1.01	11.48 1.07	12.14 1.13	12.80 1.19
36 0.91	1.09 0.10	1.93 0.18	2.77 0.26	3.61 0.34	4.45 0.31	5.30 0.49	6.14 0.57	6.98 0.65	7.82 0.73	8.66 0.81	9.50 0.88	10.34 0.96	11.19 1.04	12.03 1.12	12.87 1.20	13.71 1.28	14.55 1.35	15.39 1.43	16.24 1.51
42 1.07	1.32 0.05	2.34 0.09	3.36 0.13	4.38 0.17	5.40 0.21	6.41 0.25	7.43 0.29	8.45 0.33	9.47 0.37	10.49 0.41	11.51 0.45	12.53 0.49	13.55 0.53	14.57 0.57	15.59 0.61	16.61 0.65	17.63 0.69	18.65 0.73	19.67 0.77
48 1.22	1.45 0.14	2.58 0.24	3.70 0.34	4.83 0.45	5.96 0.55	7.08 0.66	8.21 0.76	9.33 0.87	10.46 0.97	11.58 1.08	12.71 1.18	13.83 1.29	14.96 1.39	16.08 1.50	17.21 1.60	18.33 1.71	19.46 1.81	20.58 1.91	21.71 2.02
54 1.37	1.68 0.16	2.99 0.28	4.29 0.40	5.59 0.52	6.90 0.64	8.20 0.76	9.50 0.88	10.81 1.01	12.11 1.13	13.41 1.25	14.72 1.37	16.02 1.49	17.32 1.61	18.63 1.73	19.93 1.85	21.23 1.97	22.54 2.10	23.84 2.22	25.14 2.34
60 1.52	1.91 0.18	3.39 0.32	4.88 0.45	6.36 0.59	7.84 0.73	9.32 0.87	10.80 1.00	12.28 1.14	13.76 1.28	15.24 1.42	16.73 1.56	18.21 1.69	19.69 1.83	21.19 1.97	22.65 2.11	24.13 2.24	25.61 2.38	27.09 2.52	28.57 2.66
66 1.68	2.14 0.20	3.80 0.35	5.46 0.51	7.12 0.66	8.78 0.82	10.44 0.97	12.10 1.13	13.76 1.28	15.42 1.43	17.08 1.59	18.73 1.74	20.39 1.90	22.05 2.05	23.71 2.21	25.37 2.36	27.03 2.51	28.69 2.67	30.35 2.82	32.01 2.98
72 1.83	2.37 0.22	4.21 0.39	6.05 0.56	7.88 0.73	9.72 0.90	11.56 1.07	13.40 1.25	15.23 1.42	17.07 1.59	18.91 1.76	20.74 1.93	22.58 2.10	24.42 2.27	26.25 2.44	28.09 2.61	29.93 2.78	31.77 2.95	33.60 3.13	35.44 3.30
78 1.98	2.51 0.23	4.45 0.41	6.40 0.59	8.34 0.78	10.28 0.96	12.22 1.14	14.17 1.32	16.11 1.50	18.05 1.68	20.00 1.86	21.94 2.04	23.88 2.22	25.82 2.40	27.77 2.58	29.71 2.76	31.65 2.94	33.60 3.12	35.54 3.31	37.48 3.49
84 2.13	2.74 0.25	4.86 0.45	6.98 0.65	9.10 0.85	11.22 1.04	13.34 1.24	15.46 1.44	17.58 1.64	19.71 1.83	21.83 2.03	23.95 2.23	26.07 2.42	28.19 2.62	30.31 2.82	32.43 3.02	34.55 3.21	36.67 3.41	38.79 3.61	40.91 3.80
90 2.29	2.97 0.28	5.27 0.49	7.57 0.70	9.87 0.92	12.16 1.13	14.46 1.35	16.76 1.56	19.06 1.77	21.36 1.99	23.66 2.20	25.96 2.41	28.25 2.63	30.55 2.84	32.85 3.06	35.15 3.27	37.45 3.48	39.75 3.70	42.05 3.91	44.35 4.12

PRESSURE DROP

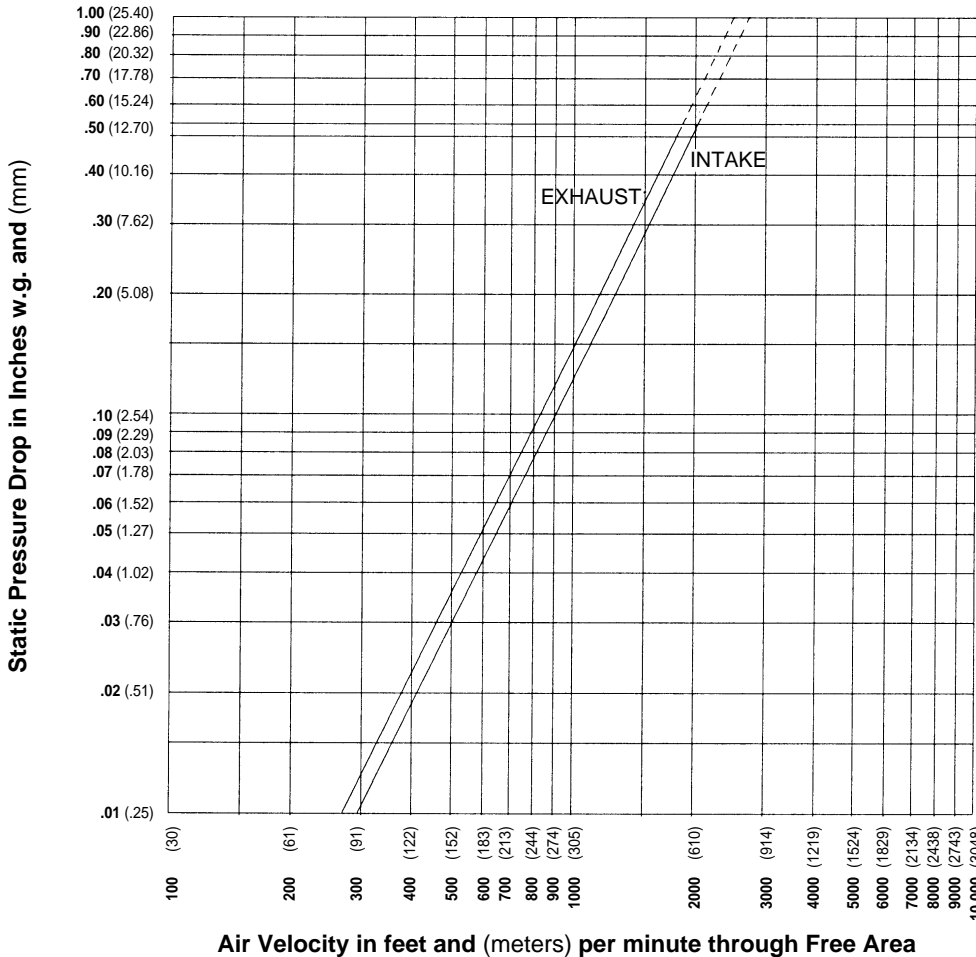

Ratings do not include the effect of a bird screen.

TYPICAL INSTALLATION DETAILS

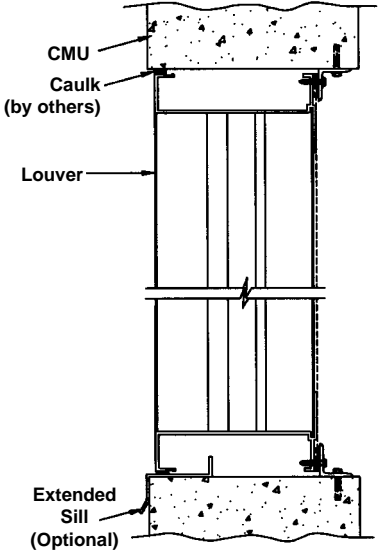
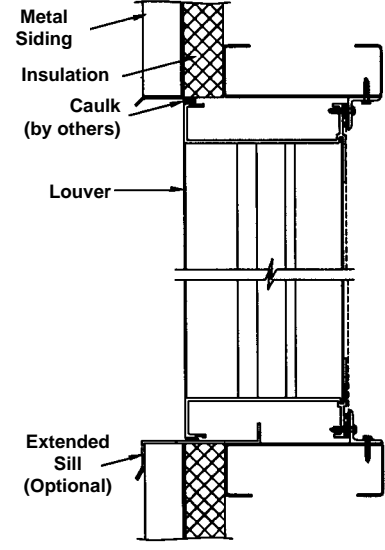
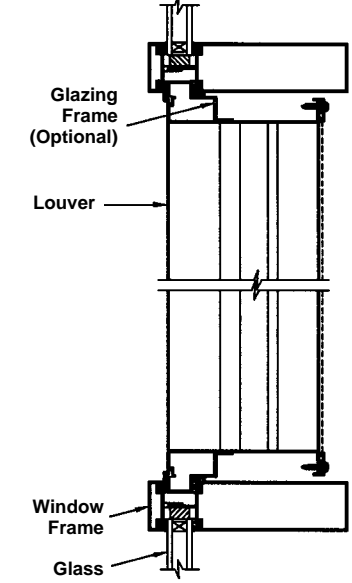
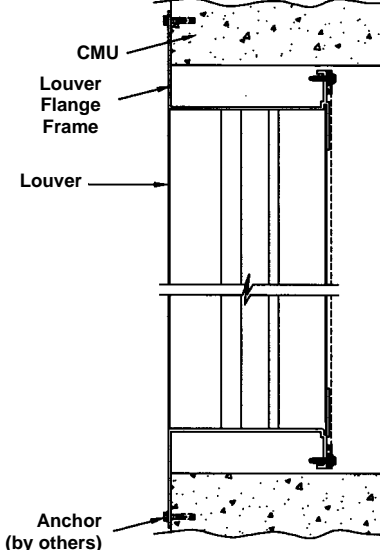
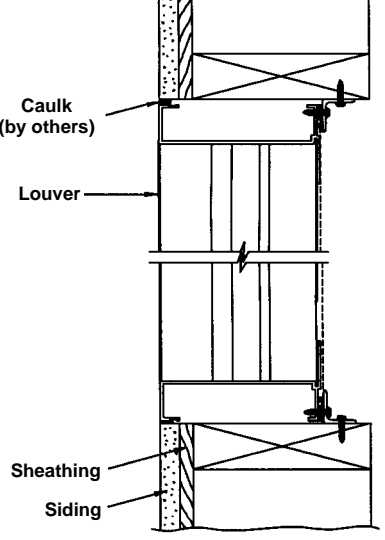
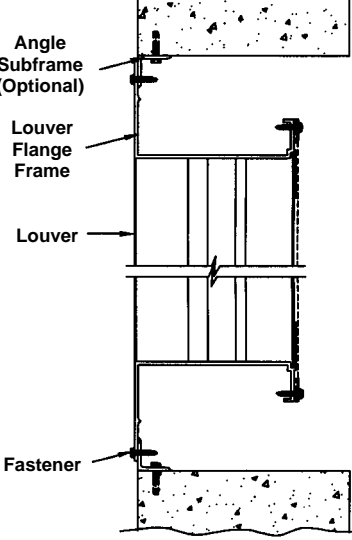
Masonry Wall	Metal Panel Wall	Glazing Frame
 <p>CMU Caulk (by others) Louver Extended Sill (Optional)</p>	 <p>Metal Siding Insulation Caulk (by others) Louver Extended Sill (Optional)</p>	 <p>Glazing Frame (Optional) Louver Window Frame Glass</p>
Flange Mount	Wood Installation	Angle Subframe
 <p>CMU Louver Flange Frame Louver Anchor (by others)</p>	 <p>Caulk (by others) Louver Sheathing Siding</p>	 <p>Angle Subframe (Optional) Louver Flange Frame Louver Fastener</p>

Options at additional cost.

RUSKIN®

3900 Dr. Greaves Rd.
Kansas City, MO 64030
(816) 761-7476
FAX (816) 765-8955
www.ruskin.com