



3900 Dr. Greaves Rd. • Kansas City, MO 64030 • (816) 761-7476 • FAX (816) 765-8955

**ELF375DXH DRAINABLE STATIONARY LOUVERS**  
EXTRUDED ALUMINUM

**STANDARD CONSTRUCTION**

**FRAME**

4" (102) deep, 6063T6 extruded aluminum. .125" (3.2) nominal wall thickness. Downspouts and caulking surfaces provided.

**BLADES**

6063T6 extruded aluminum. .125" (3.2) nominal wall thickness. Drainable blades are positioned at 37 1/2° angle and spaced approximately 5 3/32" (129) center to center.

**SCREEN**

5/8" x .040" (16 x 1) expanded, flattened aluminum bird screen in removable frame. Screen adds approximately 1/2" (13) to louver depth.

**FINISH**

Mill.

**MINIMUM SIZE**

12"w x 12"h (305 x 305).

**APPROXIMATE SHIPPING WEIGHT**

ELF375DXH - 6 lbs./ft.<sup>2</sup> (29.3 kg/m<sup>2</sup>).

**MAXIMUM FACTORY ASSEMBLY SIZE**

Single sections shall not exceed 120"w x 90"h (3048 x 2286) or 90"w x 120"h (2286 x 3048). Louvers larger than the maximum single section size will require field assembly of smaller sections.

**BLADE SUPPORTS**

Louvers may be provided with rear mounted blade supports that increase overall louver depth depending on louver size, assembly configuration or windload.

Consult Ruskin for additional information.

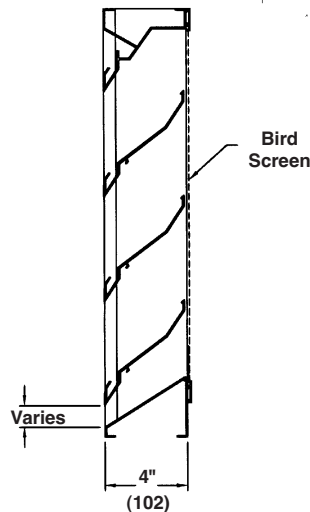
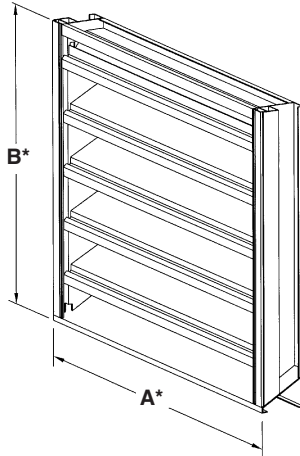

**FEATURES**

The ELF375DXH offers:

- 54% Free Area.
- Published performance ratings based on testing in accordance with AMCA Publication 511.
- High performance frame system with drainable head collects and removes water to provide excellent water penetration performance.
- Drain gutter in each blade minimizes water cascade between blades.
- Architecturally styled, hidden mullions allowing continuous line appearance up to 120" (3048).
- Aluminum construction for low maintenance and high resistance to corrosion.
- All welded construction.

**VARIATIONS**

Variations to the basic design of these louvers are available at additional cost. They include:

- Extended sill.
- Hinged frame.
- Front or rear security bars.
- Filter racks.
- A variety of bird and insect screens.
- Selection of finishes: prime coat, 50% PVDF, 70% PVDF, epoxy, Pearledize 50 & 70 (mica), clear and color anodize. (Some variation in anodize color consistency is possible.)

Consult Ruskin for other special requirements.

**FRAME CONSTRUCTION**

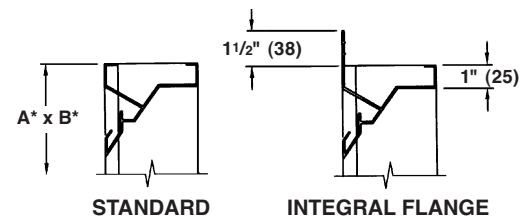

\*Units furnished 1/4" (6) smaller than given opening dimensions.

**LEED Material Information**

Contact Ruskin for Recycled Material and Manufacturing Location Information.

Dimensions in inches, parenthesis ( ) indicate millimeters.

TAG	QTY.	SIZE		FRAME	VARIATIONS
		A*-WIDE	B*-HIGH		
<b>PROJECT</b>			<b>LOCATION</b>		
<b>ARCH./ENGR.</b>			<b>CONTRACTOR</b>		
<b>REPRESENTATIVE</b>			<b>DATE</b>		

# SUGGESTED SPECIFICATION

## GENERAL

Furnish and install at locations shown on the plans or as described in schedules drainable louvers. Stationary louvers shall be manufactured in an ISO 9001 certified factory.

Stationary louvers shall be furnished with bird and/or insect screens, supports and finishes as specified and as required for a complete installation. Stationary louvers shall incorporate drainable stationary blade. All blades and frames shall be constructed of 6063-T5 aluminum alloy.

## MATERIAL

Stationary louvers shall be 4" (102) deep. Louver blade and frame nominal wall thickness shall be .125" (3.2). Integral gutters shall be incorporated into blades, louver head and jamb frames.

## PERFORMANCE

The louver shall be AMCA certified for Water Penetration and Air Performance conforming to the following minimum requirements: Free Area: 8.58 Square Feet (0.80 m<sup>2</sup>).

Maximum pressure drop at 1000 fpm (305 m/min): 0.20" w.g. (0.05 kPA).

Free Area Velocity at Beginning Point of Water Penetration: 873 fpm (+266 m/min).

## PERFORMANCE DATA

AMCA Standard 500 provides a reasonable basis for testing and rating louvers. Testing to AMCA 500 is performed under a certain set of laboratory conditions. This does not guarantee that other conditions will not occur in the actual environment where louvers must operate.

The louver system should be designed with a reasonable safety factor for louver performance. To ensure protection from water carryover, design with a performance level somewhat below maximum desired pressure drop and .01 oz./sq. ft. of water penetration.

## STRUCTURAL DESIGN

Integral structural supports shall be designed and furnished by the louver manufacturer to carry a wind load of not less than 20 psf (.96 kPA).

## FINISH

Stationary louvers shall be finished as specified by the architect. Painted finishes shall include the following minimum requirements. All Kynar finishes shall be applied at 1.2 mil total dry film thickness and meet the following AAMA standards. 70% Kynar finishes shall meet AAMA 2605-05 for organic coatings and exterior aluminum finishes requiring 10 years of South Florida exposure. 50% Kynar finishes shall meet AAMA 2604-05 for organic coatings and exterior aluminum finishes requiring 5 years of South Florida exposure.

Louver manufacturer shall provide 20 year limited warranty for fluoropolymer-based finishes. 10-year warranties shall not be acceptable. Finish coating shall not peel, blister, chip, crack or check. Chalking and fading of finish shall not exceed the maximum limits identified in the manufacturers finish warranty.

This warranty shall begin on the date of material shipment.

Stationary Louver shall be *Ruskin*<sup>®</sup> model ELF375DXH.

(Consult [www.ruskin.com](http://www.ruskin.com) for electronic version of this "Quick" spec as well as for complete 3- part CSI MasterFormat Specifications).

## WATER PENETRATION

Test size 48" wide x 48" high (1219 x 1219)  
**Beginning point of water penetration  
 at .01 oz./sq. ft. is 873 fpm (266 m/min).**

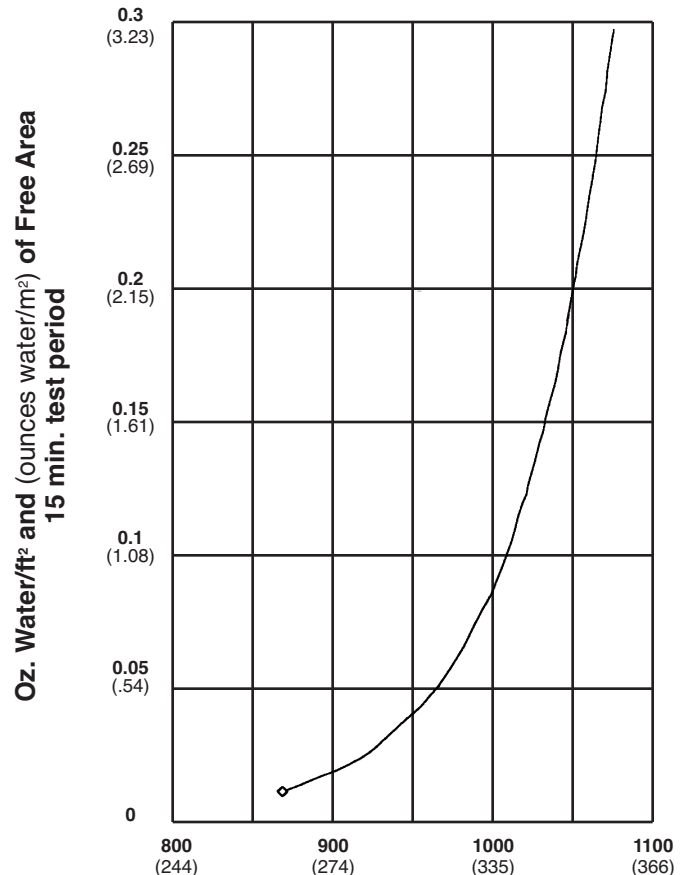

Free Area Velocity in feet and (meters) per minute  
 Standard air .075 lb/ft<sup>3</sup>

# FREE AREA GUIDE

Free Area Guide shows free area in ft<sup>2</sup> and m<sup>2</sup> for various sizes of ELF375DXH  
Width – Inches and Meters

Height – Inches and Meters	12	18	24	30	36	42	48	54	60	66	72	78	84	90	96	102	108	114	120
	0.30	0.46	0.61	0.76	0.91	1.07	1.22	1.37	1.52	1.68	1.83	1.98	2.13	2.29	2.44	2.59	2.74	2.90	3.05
12 0.30	0.26 0.02	0.41 0.04	0.56 0.05	0.71 0.07	0.87 0.08	1.02 0.09	1.17 0.11	1.33 0.12	1.48 0.14	1.63 0.15	1.79 0.17	1.94 0.18	2.09 0.19	2.24 0.21	2.40 0.22	2.55 0.24	2.70 0.25	2.86 0.27	3.01 0.28
18 0.46	0.61 0.06	0.97 0.09	1.33 0.12	1.70 0.16	2.06 0.19	2.43 0.23	2.79 0.26	3.15 0.29	3.52 0.33	3.88 0.36	4.25 0.39	4.61 0.43	4.97 0.46	5.34 0.50	5.70 0.53	6.06 0.56	6.43 0.60	6.79 0.63	7.16 0.67
24 0.61	0.87 0.08	1.40 0.13	1.92 0.18	2.45 0.23	2.97 0.28	3.50 0.33	4.02 0.37	4.55 0.42	5.07 0.47	5.60 0.52	6.12 0.57	6.65 0.62	7.17 0.67	7.70 0.72	8.22 0.76	8.75 0.81	9.27 0.86	9.80 0.91	10.32 0.96
30 0.76	1.14 0.11	1.83 0.17	2.51 0.23	3.20 0.30	3.89 0.36	4.57 0.42	5.26 0.49	5.94 0.55	6.63 0.62	7.32 0.68	8.00 0.74	8.69 0.81	9.37 0.87	10.06 0.93	10.74 1.00	11.43 1.06	12.12 1.13	12.80 1.19	13.49 1.25
36 0.91	1.33 0.12	2.13 0.20	2.92 0.27	3.72 0.35	4.52 0.42	5.31 0.49	6.11 0.57	6.91 0.64	7.70 0.72	8.50 0.79	9.30 0.86	10.09 0.94	10.89 1.01	11.69 1.09	12.49 1.16	13.28 1.23	14.08 1.31	14.88 1.38	15.67 1.46
42 1.07	1.60 0.15	2.55 0.24	3.51 0.33	4.47 0.42	5.43 0.50	6.39 0.59	7.34 0.68	8.30 0.77	9.26 0.86	10.22 0.95	11.18 1.04	12.13 1.13	13.09 1.22	14.05 1.31	15.01 1.39	15.96 1.48	16.92 1.57	17.88 1.66	18.84 1.75
48 1.22	1.86 0.17	2.98 0.28	4.10 0.38	5.22 0.49	6.34 0.59	7.46 0.69	8.58 0.80	9.70 0.90	10.82 1.01	11.93 1.11	13.05 1.21	14.17 1.32	15.29 1.42	16.41 1.52	17.53 1.63	18.65 1.73	19.77 1.84	20.89 1.94	22.00 2.04
54 1.37	2.13 0.20	3.41 0.32	4.69 0.44	5.97 0.55	7.25 0.67	8.53 0.79	9.81 0.91	11.09 1.03	12.37 1.15	13.65 1.27	14.93 1.39	16.21 1.51	17.49 1.63	18.77 1.74	20.05 1.86	21.33 1.98	22.61 2.10	23.89 2.22	25.17 2.34
60 1.52	2.40 0.22	3.84 0.36	5.28 0.49	6.72 0.62	8.16 0.76	9.61 0.89	11.05 1.03	12.49 1.16	13.93 1.29	15.37 1.43	16.81 1.56	18.25 1.70	19.69 1.83	21.13 1.96	22.57 2.10	24.01 2.23	25.45 2.37	26.90 2.50	28.34 2.63
66 1.68	2.59 0.24	4.14 0.38	5.69 0.53	7.24 0.67	8.79 0.82	10.35 0.96	11.90 1.11	13.45 1.25	15.00 1.39	16.55 1.54	18.11 1.68	19.66 1.83	21.21 1.97	22.76 2.12	24.31 2.26	25.86 2.40	27.41 2.55	28.97 2.69	30.52 2.84
72 1.83	2.85 0.26	4.57 0.42	6.28 0.58	7.99 0.74	9.71 0.90	11.42 1.06	13.13 1.22	14.84 1.38	16.56 1.54	18.27 1.70	19.98 1.86	21.70 2.02	23.41 2.18	25.12 2.33	26.83 2.49	28.55 2.65	30.26 2.81	31.97 2.97	33.69 3.13
78 1.98	3.12 0.29	5.00 0.46	6.87 0.64	8.74 0.81	10.62 0.99	12.49 1.16	14.37 1.34	16.24 1.51	18.11 1.68	19.99 1.86	21.86 2.03	23.74 2.21	25.61 2.38	27.48 2.55	29.36 2.73	31.23 2.90	33.10 3.08	34.98 3.25	36.85 3.42
84 2.13	3.39 0.32	5.43 0.50	7.46 0.69	9.50 0.88	11.53 1.07	13.57 1.26	15.60 1.44	17.63 1.64	19.67 1.83	21.70 2.02	23.74 2.21	25.77 2.39	27.81 2.58	29.84 2.77	31.88 2.96	33.91 3.15	35.95 3.34	37.98 3.53	40.02 3.72
90 2.29	3.66 0.34	5.86 0.54	8.05 0.75	10.25 0.95	12.44 1.16	14.64 1.36	16.83 1.56	19.03 1.77	21.23 1.97	23.42 2.18	25.62 2.38	27.81 2.58	30.01 2.79	32.20 2.99	34.40 3.20	36.60 3.40	38.79 3.60	40.99 3.81	43.18 4.01

## PRESSURE DROP

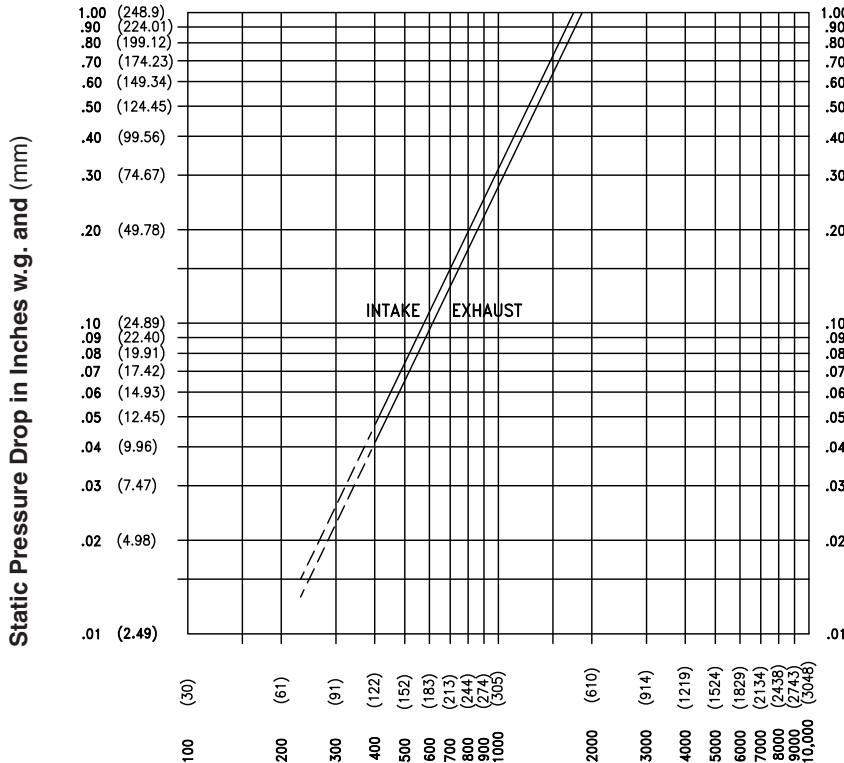

Ratings do not include the effect of a bird screen.



Ruskin® Company certifies that the ELF375DXH Louvers shown herein are licensed to bear the AMCA Seal. The ratings shown are based on tests and procedures performed in accordance with AMCA Publication 511 and comply with the requirements of the AMCA Certified Ratings Program. The AMCA Certified Ratings Seal applies to air performance ratings and water penetration ratings only.

Air Velocity in feet and (meters) per minute through Free Area  
(Data corrected to standard air density and AMCA figure tested to 5.5)

# TYPICAL INSTALLATION DETAILS

## Masonry Wall

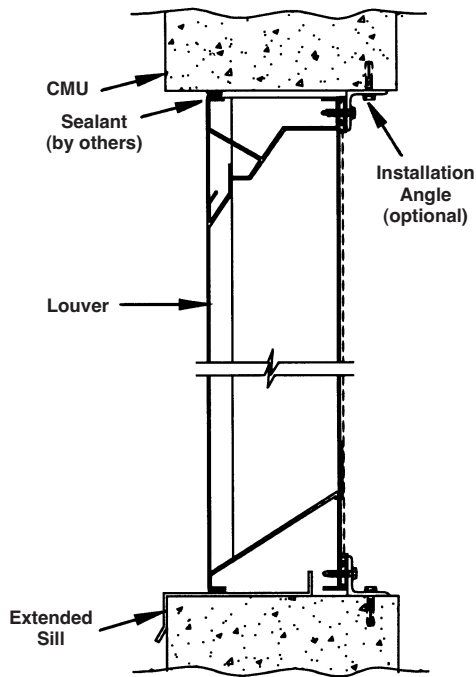

## Metal Panel Wall

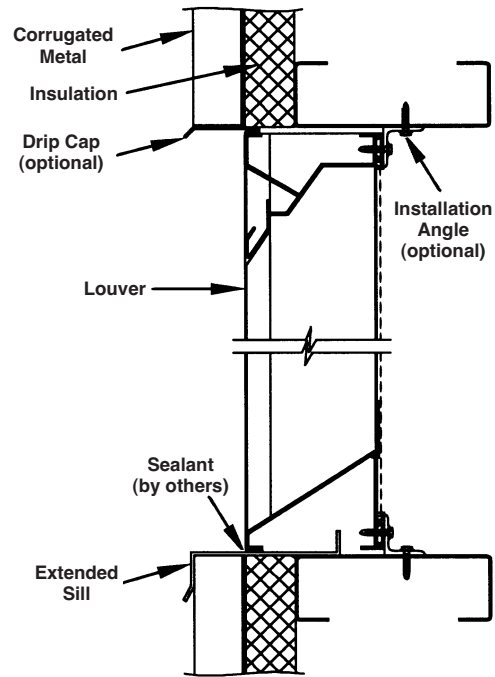

## Wood Installation

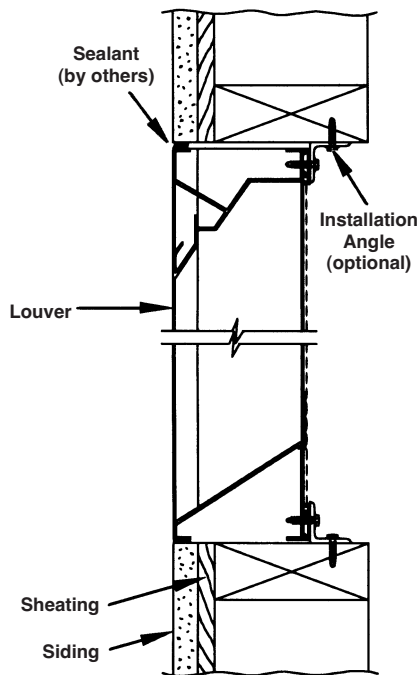

## Flange Mount

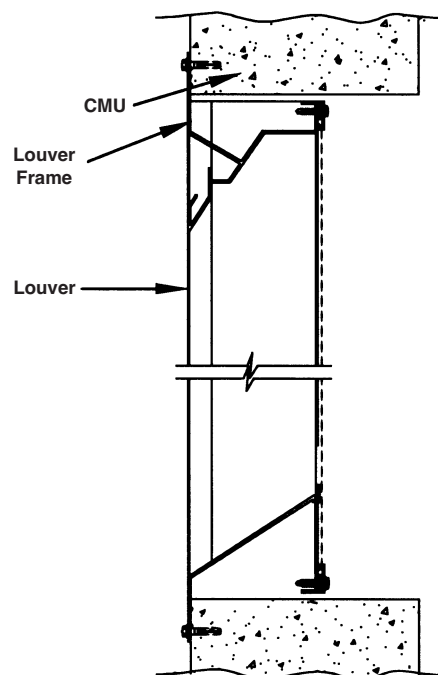

Options are available at additional cost. Fasteners into substrate are not provided by Ruskin®.

**RUSKIN**®

3900 Dr. Greaves Rd.  
Kansas City, MO 64030  
(816) 761-7476  
FAX (816) 765-8955  
www.ruskin.com

Printed on recycled paper  
using vegetable based inks

