

ACL445 STATIONARY ACOUSTICAL LOUVER FORMED STEEL

STANDARD CONSTRUCTION

FRAME

4" (102) deep, 16 gage (1.6) galvanized steel channel.

BLADES

18 gage (1.3) galvanized steel exterior surface, with 22 gage (.9) perforated steel interior surface that covers insulation. Blades positioned at 45° angle and spaced approximately 6" (152) center to center.

INSULATION

Ruskatherm blanket.

SCREEN

1/2" mesh x 19 gage (13 x 1.1) galvanized bird screen in removable frame. Screen adds approximately 1/2" (13) to louver depth.

FINISH

Mill.

MINIMUM SIZE

12"w x 18"h (305 x 457).

APPROXIMATE SHIPPING WEIGHT

5 lbs. per sq. ft.

MAXIMUM FACTORY ASSEMBLY SIZE

Shall be 64 sq. ft. (6m²). Maximum single section size shall be 48" x 96" (1219 x 2438). Louvers larger than the maximum single section size will require field assembly of smaller sections.

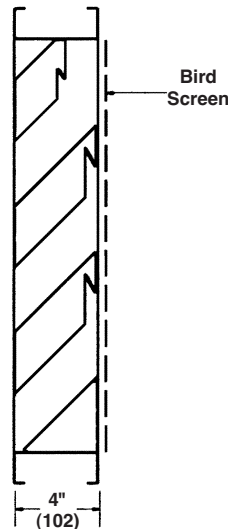
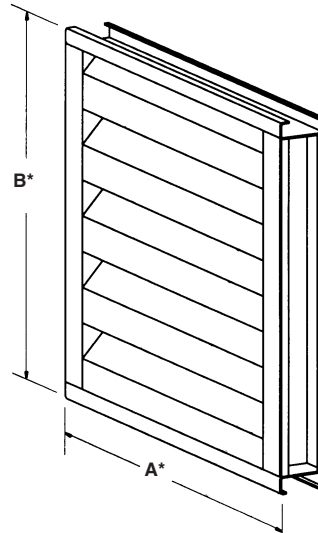

FEATURES

The ACL445 offers insulated blades which provide effective sound attenuation and weather protection with an architecturally pleasing appearance.

VARIATIONS

Variations to the basic design of this louver are available at additional cost. They include:

- Extended sill.
- Front or rear security bars.
- Filter racks.
- A variety of bird and insect screens.
- Selection of finishes: baked enamel (modified fluoropolymer), epoxy, Kynar, Acrodize, prime coat, integral color and clear anodize. (Some variation in anodize color consistency is possible.) (Anodize finish available only on aluminum construction.)
- Formed aluminum frame with .100" (2.5) nominal wall thickness and .080" (1.6) blade with .040" (1) perforated aluminum interior surface.

Octave Band Frequency (Hz)	Free Field Noise Reduction (db) Ruskatherm Blanket
1/63	9
2/125	11
3/250	9
4/500	11
5/1000	15
6/2000	17
7/4000	16
8/8000	16

To calculate Transmission Loss (db), subtract 6 db from Free Field Noise Reduction (db).

Dimensions in parenthesis () indicate millimeters.

Units furnished 1/4" (6) smaller than given opening dimensions.

TAG	QTY.	SIZE		FRAME	VARIATIONS
		A"-WIDE	B"-HIGH		
PROJECT			LOCATION		
ARCH./ENGR.			CONTRACTOR		
REPRESENTATIVE			DATE		

SUGGESTED SPECIFICATION

Furnish and install louvers as hereinafter specified where shown on plans or as described in schedules. Louvers shall be stationary acoustical type contained within a 4" (102) frame. Louver components (heads, jambs, sills, blades, and mullions) shall be factory assembled by the louver manufacturer. Louver sizes too large for shipping shall be built up by the contractor from factory assembled louver sections to provide overall sizes required. Louver design shall incorporate structural supports required to withstand a wind-load of 20 lbs. per sq. ft. (.96kPa) (equivalent of a 90 mph wind [145 KPH] - specifier may substitute any loading required).

Louvers shall be Ruskin Model ACL445 construction as follows:

- Frame: 16 gage (1.6) galvanized steel channel.
- Blades: 20 gage (1.0) galvanized steel exterior surface, 22 gage (.9) perforated steel interior surface that covers insulation. Blade angle 45° on 6" (152) centers.
- Screen: 1/2" mesh x 19 gage (13 x 1.1) galvanized steel in removable frame.
- Finish: Select finish specification from Ruskin/Valspar Finishes Brochure.

Published louver performance data bearing the AMCA Certified Ratings Seal for Air Performance must be submitted for approval prior to fabrication and must demonstrate pressure drop equal to or less than the Ruskin model specified.

PERFORMANCE DATA

AMCA Standard 500 provides a reasonable basis for testing and rating louvers. Testing to AMCA 500 is performed under a certain set of laboratory conditions. This does not guarantee that other conditions will not occur in the actual environment where louvers must operate.

The louver system should be designed with a reasonable safety factor for louver performance. To ensure protection from water carryover, design with a performance level somewhat below maximum desired pressure drop and .01 oz./sq. ft. of water penetration.

WATER PENETRATION

Test size 48" wide x 48" high (1219 x 1219)

Beginning point of water penetration at .01 oz./sq. ft. is 512 fpm (156 m/min).

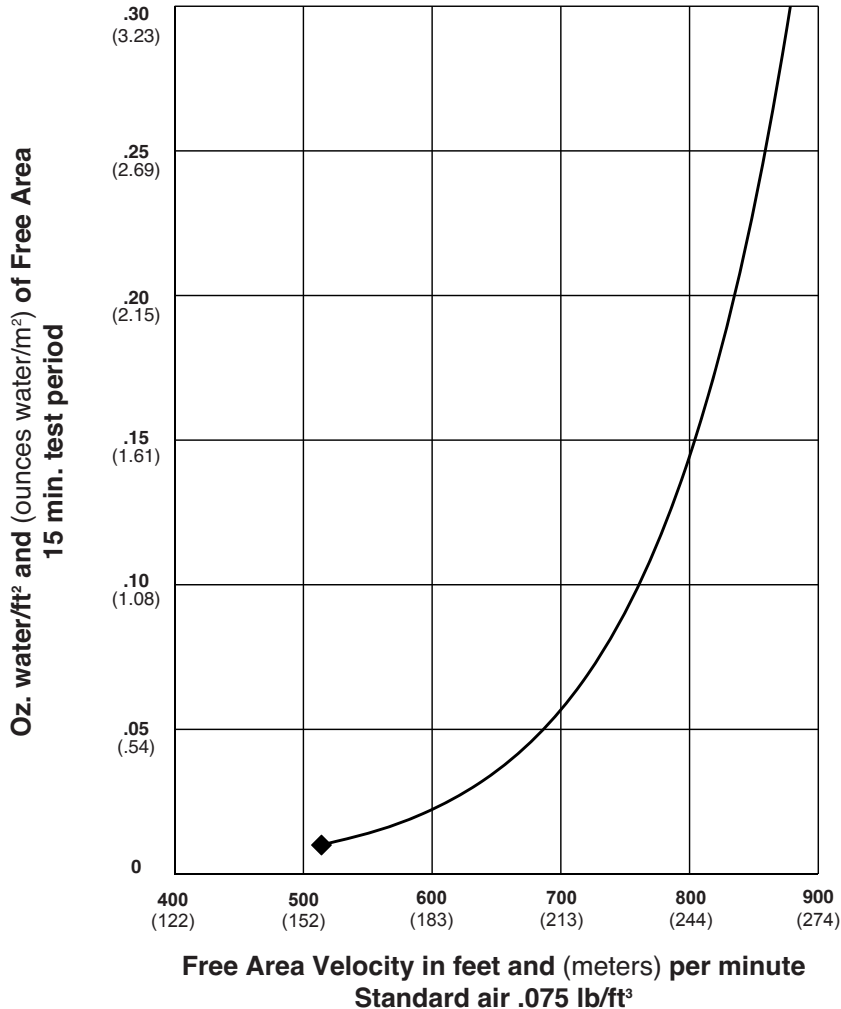

FREE AREA GUIDE

Free Area Guide shows free area in ft² and m² for various sizes of ACL445

Height – Inches and Meters	12	18	24	30	36	42	48
	0.30	0.46	0.61	0.76	0.91	1.07	1.22
18 0.46	0.25 0.02	0.42 0.04	0.58 0.05	0.75 0.07	0.92 0.09	1.08 0.10	1.25 0.12
24 0.61	0.38 0.03	0.63 0.06	0.88 0.08	1.13 0.10	1.38 0.13	1.63 0.15	1.88 0.17
30 0.76	0.50 0.05	0.84 0.08	1.17 0.11	1.51 0.14	1.84 0.17	2.17 0.20	2.51 0.23
36 0.91	0.63 0.06	1.05 0.10	1.46 0.14	1.88 0.18	2.30 0.21	2.72 0.25	3.14 0.29
42 1.07	0.75 0.07	1.26 0.12	1.76 0.16	2.26 0.21	2.76 0.26	3.27 0.30	3.77 0.35
48 1.22	0.88 0.08	1.47 0.14	2.05 0.19	2.64 0.25	3.23 0.30	3.81 0.35	4.40 0.41
54 1.37	1.01 0.09	1.68 0.16	2.35 0.22	3.02 0.28	3.69 0.34	4.36 0.41	5.03 0.47
60 1.52	1.13 0.11	1.89 0.18	2.64 0.25	3.39 0.32	4.15 0.39	4.90 0.46	5.66 0.53
66 1.68	1.26 0.12	2.10 0.19	2.93 0.27	3.77 0.35	4.61 0.43	5.45 0.51	6.29 0.58
72 1.83	1.38 0.13	2.31 0.21	3.23 0.30	4.15 0.39	5.07 0.47	5.99 0.56	6.92 0.64
78 1.98	1.51 0.14	2.52 0.23	3.52 0.33	4.53 0.42	5.53 0.51	6.54 0.61	7.55 0.70
84 2.13	1.64 0.15	2.73 0.25	3.82 0.35	4.91 0.46	6.00 0.56	7.09 0.66	8.18 0.76
90 2.29	1.76 0.16	2.94 0.27	4.11 0.38	5.28 0.49	6.46 0.60	7.63 0.71	8.81 0.82
96 2.44	1.89 0.18	3.15 0.29	4.40 0.41	5.66 0.53	6.92 0.64	8.18 0.76	9.44 0.88



Ruskin Company certifies that the louver shown herein is licensed to bear the AMCA Seal. The ratings shown are based on tests and procedures performed in accordance with AMCA Standard 511 and comply with the requirements of the AMCA Certified Ratings Program. AMCA Certified Ratings Seal applies to air performance ratings and water penetration ratings only.

Width – Inches and Meters

PRESSURE DROP

Test size 48" wide x 48" high (1219 x 1219) Tested to AMCA Figure 5.5

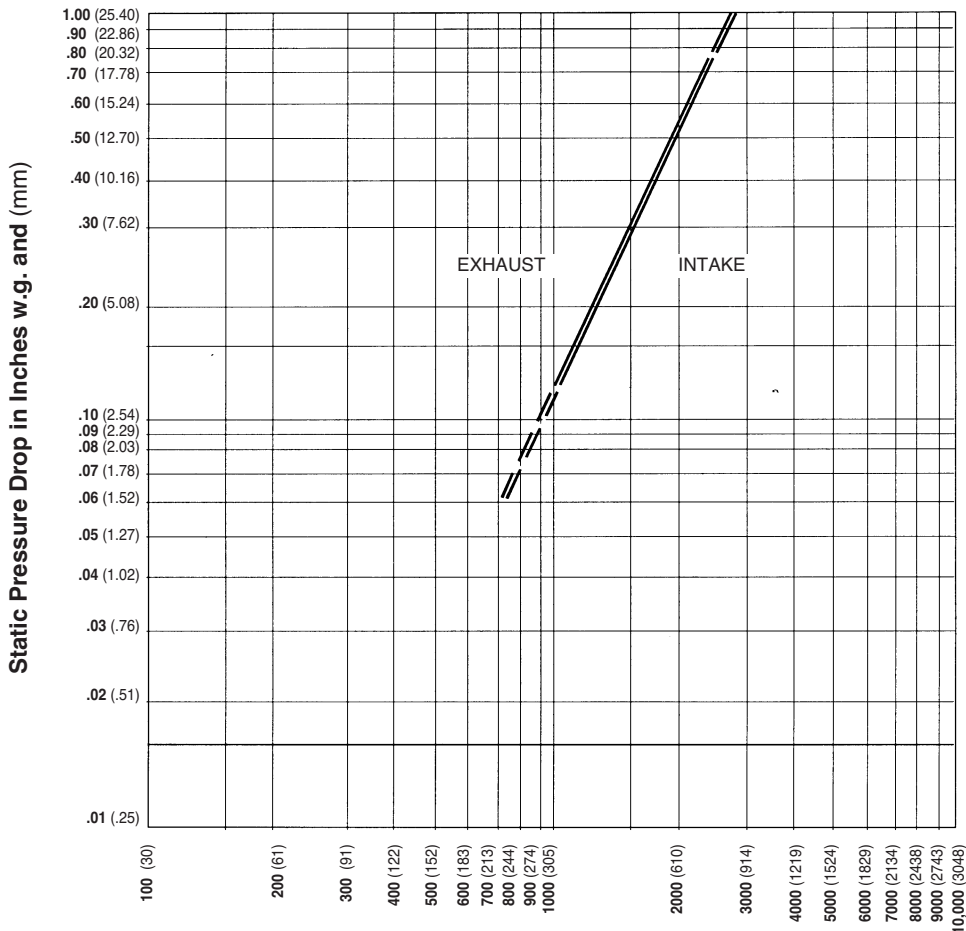

Ratings do not include the effect of a bird screen.

Air Velocity in feet and (meters) per minute through Free Area

(Data corrected to standard air density and AMCA figure or figures tested to 5.5)

TYPICAL INSTALLATION DETAILS

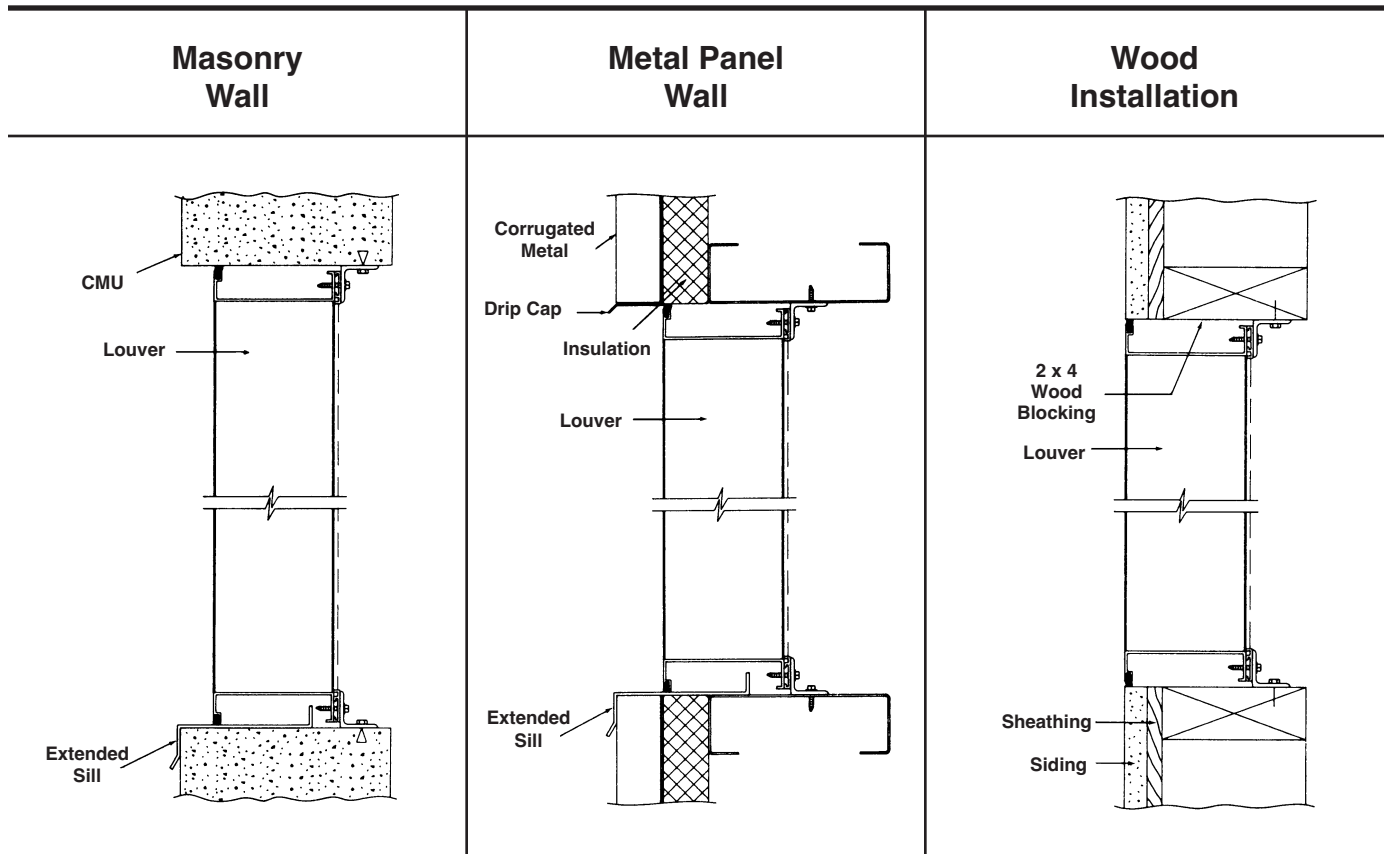

Accessories at additional cost.