

TURNING AIR INTO SOLUTIONS.

Fan & Blower

Twin City



BACKWARD CURVED HIGH PRESSURE COMPOSITE FANS

Model BCSF

**CATALOG 410
December 2016**

COMPOSITE FANS



Overview

BCSF

The BCSF fan from Twin City Fan & Blower is a backward curved industrial fan designed for handling particulate free, corrosive or caustic air in high pressure applications where conventional steel and stainless steel fans are not suitable.

Model BCSF is designed so all parts exposed to the airstream are constructed of, or protected with, high-quality corrosion resistant materials to avoid material breakdown from most chemicals.

Model BCSF features a wide wheel and housing, producing a high volume of air at a lower velocity, therefore the need for an expansion easé is eliminated.

Typical Applications Include

Fume Control, Fume Exhausting, Odor Control, Oil Mist Emissions, Pollution/Emissions Control, Process Control (Heating or Cooling), Scrubbers

Typical Industries Include

Fertilizer, Metal/Mineral Processing, Pulp and Paper, Petrochemical, Pharmaceutical, Water and Wastewater Treatment

Arrangements

Available in Arrangements 1, 8, 9, 9F and 10
Direct Drive & Belt Driven Configurations

Wheel Types

Backward Curved

Standard Construction

Class FS & CF

Optional Construction

ASTM D4167

Certifications

AMCA Sound/Air and FEG



BCSF Arrg. 1



BCSF Wheel



Twin City Fan & Blower, a Twin City Fan Company, certifies that the BCSF High Pressure Composite Fans shown herein are licensed to bear the AMCA Seal. The ratings shown are based on tests and procedures performed in accordance with AMCA Publication 211 and AMCA Publication 311 and comply with the AMCA Certified Ratings Program. See Catalog 411 for sound ratings.



For complete product performance, drawings, and available accessories, Download Fan Selector 10 at tcf.com.

Overview

BCSF

The BCSF industrial fan, with its patent pending backward-curved wheel, is designed to provide long-lasting, efficient performance for corrosive applications.

Suitable for indoor and outdoor applications, the BCSF is an ideal choice for applications in municipal and private sectors.

Sizes and Performance

- 16.5" to 60" wheel diameters
- Airflow to 151,000 CFM
- Static pressure to 34" w.g.
- Airstream temperature to 200° F

Wheel Designs

The BCSF features a non-overloading wheel design suitable for applications requiring large volumes of air at moderate to high pressures. The high efficiency wheel features backward curved blades of single thickness affixed to the rim and backplate through a patent-pending three-way fastening design.

Four discrete wheel designs are available for the BCSF product line. Two medium pressure wheels (M1 and M2) and two high pressure wheels (H1 and H2).

- Medium Pressure (M1 and M2) — for tip speeds to 24,500 FPM
- High Pressure (H1 and H2) — for tip speeds to 26,000 FPM

Fiberglass & Carbon Fiber Wheel Options

Wheels are available in fiberglass (Class FG) and carbon fiber (Class CF) construction. For other specific wheel materials of construction, please consult Twin City Fan & Blower for material suitability and compatibility to the airstream.

The composite wheel is constructed of a premium quality, corrosion resistant vinyl ester resin, reinforced with fiberglass or carbon fiber and other proprietary materials for minimal weight and optimum strength.

A conical shroud (rim) makes the BCSF less susceptible to performance losses associated with poor inlet conditions. All steel hubs, shaft and stainless steel fasteners are encapsulated for corrosion resistance. All BCSF wheels and shafts are statically and dynamically balanced as an assembly to grade G6.3 per ANSI S2.19 for smooth operation prior to assembly of the fan, followed by a final balance of the entire fan assembly.



Microchip Processing

Fan & Blower
Twin City

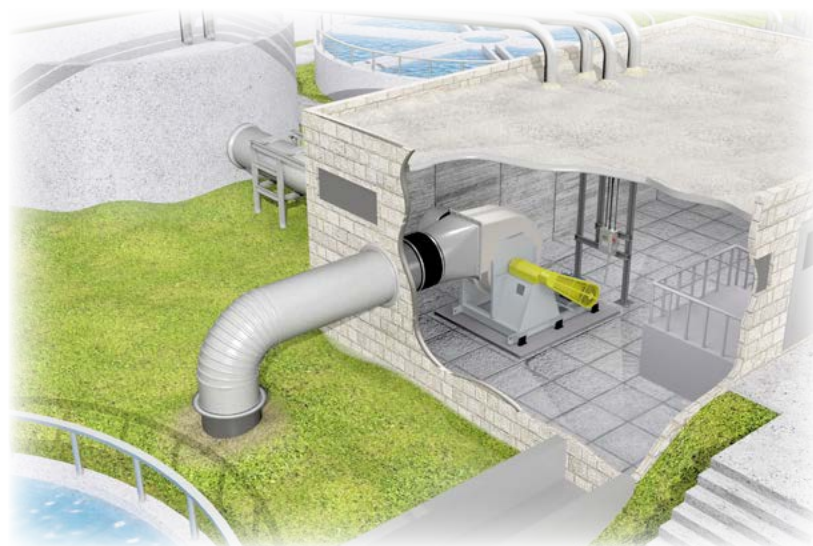

Wastewater Treatment

CONSTRUCTION FEATURES



Housing

Housings are constructed of premium quality, fiberglass reinforced resin composite in a manner ensuring a smooth airpath surface. Coupled with aerodynamically designed inlet cones the BCSF housings provide high efficiency and smooth airflow through the fan.

All housings utilize external, structural components for mounting. Mild steel structural components are mechanically fastened to the encapsulated hardware to prevent bleed-through corrosion. The mild steel bearing pedestal and non-airstream contact parts are epoxy coated for corrosion resistance. The exterior of the housing is coated with a UV resistant coating. Outlet flanges for duct connection and lifting lugs are standard.

Sizes 165 to 365 are field rotatable to one of five (5) discharge positions.

Fire Retardant Resin

Standard on the BCSF, fire retardant resin reduces the resin's tendency to burn, attaining a flame spread rating of 25 or less in accordance with the ASTM E-84 testing method.

Shaft

Shafts are AISI 1045 hot-rolled steel accurately turned, ground, polished, and ring gauged for accuracy. Shaft areas exposed to the airstream are encapsulated to prevent corrosion. Shafts are generously sized for first critical speed of at least 1.43 times the maximum speed. Stainless steel shafts available.

Bearings

Bearings are heavy-duty, grease-lubricated, anti-friction ball or roller, self-aligning, pillow block type and are selected for minimum average bearing life (AFBMA L-50) in excess of 200,000 hours at the maximum fan RPM.

Shaft Sleeve

A fiberglass shaft sleeve encapsulates the standard mild steel shaft, protecting it from the airstream environment. The sleeve is bonded to the backplate of the wheel and extends through the opening of the housing. The fiberglass shaft sleeve is only available with standard shaft seal.

Round Inlet Collar

Fiberglass inlet collar (stub) for connecting to customer-supplied round duct or flexible inlet connector.

Shaft Seal

A shaft seal reduces leakage and protects the bearings from a contaminated airstream. Standard seals are constructed of Tetraglas compressed between an aluminum cover plate and the fan housing. The standard shaft seal is not gas tight. Special seals are available for low leakage applications requiring more protection.

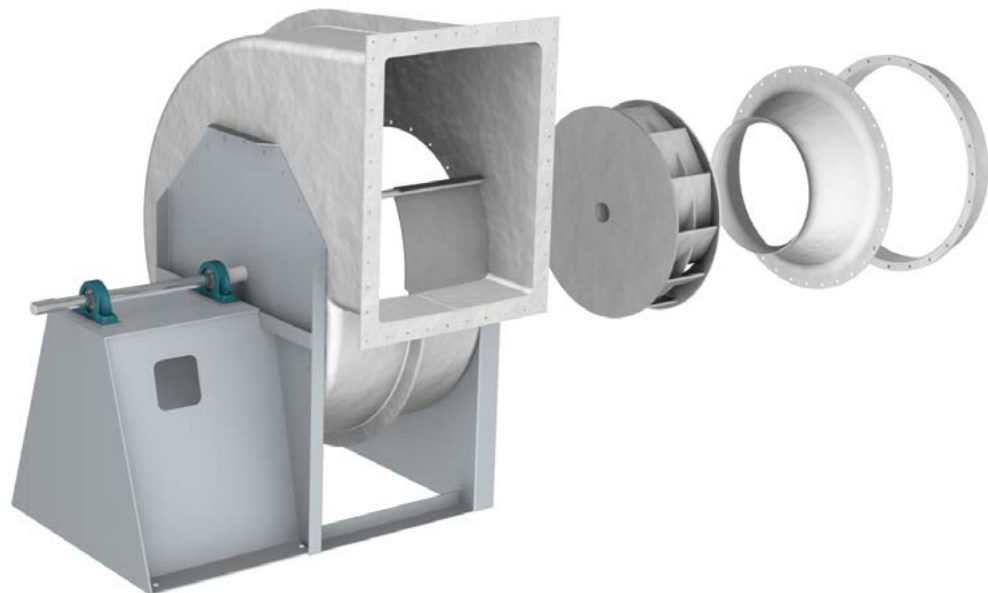

Spark Resistant Construction

Spark resistant construction for fiberglass fans is recommended when the fan is handling explosive fumes. Although fiberglass and carbon fiber are non-sparking materials, they can build and retain a static charge that can be potentially hazardous. With spark resistant construction, the fan is statically grounded by graphite impregnation to reduce a static charge buildup.

ASTM D4167 Construction

Fans constructed to meet ASTM D4167 include spark resistant construction, surface veil for the airstream and rotor assembly balanced to grade G6.3.

Special Width & Diameter Construction

Variations in wheel widths (70% to 100%) are available to match designed performance at motor speeds for the greatest efficiency for any given application.

Special Materials

Please contact Twin City Fan & Blower to ensure a suitable material is selected for the specific application.

Vinyl Ester — Provides increased corrosion resistance to stronger acids, chlorine and oxidizing agents. For use in industrial applications such as chemical and water treatment plants, and commercial applications where urban or salt air corrosion exists.

Housing construction of vinyl ester is available as an option. Wheel is constructed of vinyl ester as standard.

Surface Veil — A single layer of synthetic veil on specific airstream parts is available to increased chemical resistance. A second layer is available if necessary for the application. Consult Twin City Fan & Blower for application information.

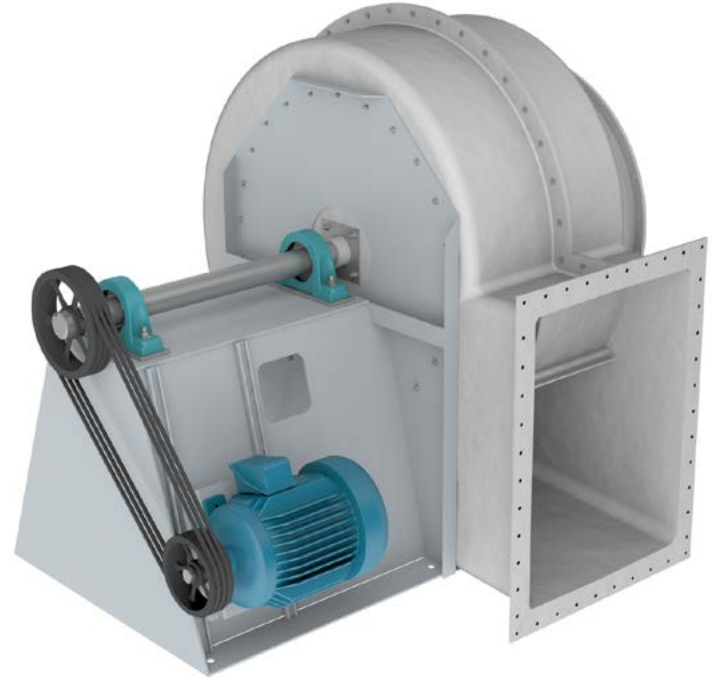

BCSF Arrg. 9

Fan & Blower
Twin City

Installations



Paper Machine Exhaust



Scrubber Fan



Wastewater Treatment
Odor Control

ARRANGEMENTS

Arrangement 1

Arrangement 1 fans are available in either direct drive (see Arrangement 8 below), or belt driven installations. The belt driven configuration allows the motor to be mounted in any of the four standard motor positions shown on page 7. The choice of a belt driven installation provides greater performance flexibility with the use of belts and sheaves of differing sizes.



Arrangement 8

Arrangement 8 fans use a fan shaft and motor direct coupled via a flexible coupling. The integral motor subbase is fabricated of heavy gauge steel and securely reinforced for rigidity. Twin City Fan & Blower can supply wheels in a variety of diameters and differing widths to give the greatest efficiency for any given application. If desired, an Arrangement 1 fan can be set up for direct drive. This requires a concrete motor pedestal to be built in the field.



Arrangement 9

Arrangement 9 fans include a motor slide base mounted on the side of the motor pedestal. The motor and drive can be installed at the factory or field installed. Refer to dimensional data on pages 33-36 for maximum motor frame sizes on Arrangement 9 fans.

Unless otherwise specified, the motor will be installed on the left (L) side of the pedestal on CW fans and on the right (R) side on CCW fans.



Arrangement 9F

Arrangement 9F is available when an Arrangement 9 requires a motor which is too large to mount on the bearing pedestal. The fan frame is extended to accommodate the motor, for horizontal mounting, similar to an Arrangement 1 fan. Arrangement 9F is not suitable for mounting vibration isolators directly under the fan.

Unless otherwise specified, the motor will be installed on the left (L) side of the pedestal on CW fans and on the right (R) side on CCW fans. Arrangement 9F requires a separate subbase when vibration isolation is required.

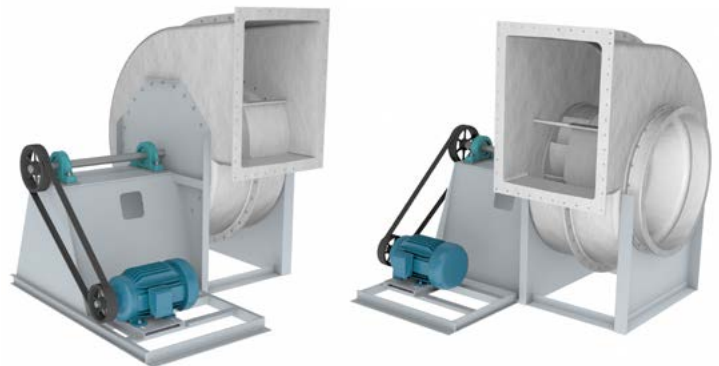

Arrangement 10

Arrangement 10 fans are suitable for roof or outdoor installations. An optional weather cover, provides complete weather protection for motor, shaft, bearings, and drives. This arrangement available on sizes up through 365. Refer to dimensional data on pages 41 and 42 for maximum motor frame sizes on Arrangement 10 fans.



CLOCKWISE (CW) - ROTATION & DISCHARGE (ROTATION VIEW FROM DRIVE SIDE)



UBD
Upblast
CW 360

TAU
Top Angular Up
CW 45

THD
Top Horizontal
CW 90

BHD
Bottom Horizontal
CW 270

BAU
Bottom Angular Up
CW 315

COUNTER CLOCKWISE (CCW) - ROTATION & DISCHARGE (ROTATION VIEW FROM DRIVE SIDE)



UBD
Upblast
CCW 360

TAU
Top Angular Up
CCW 45

THD
Top Horizontal
CCW 90

BHD
Bottom Horizontal
CCW 270

BAU
Bottom Angular Up
CCW 315

MOTOR POSITIONS

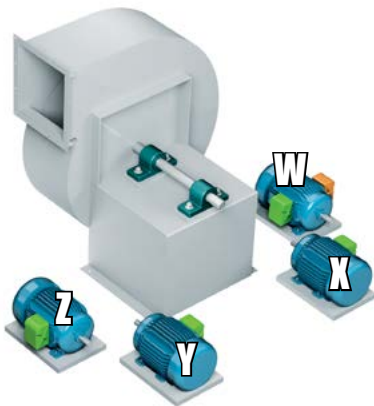

Arrangement 1



Arrangement 9



Arrangement 9F

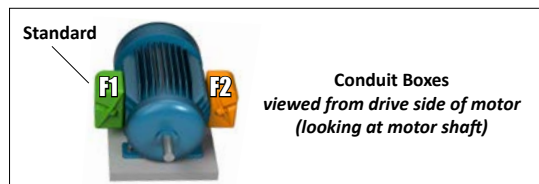

OPTIONS/ACCESSORIES

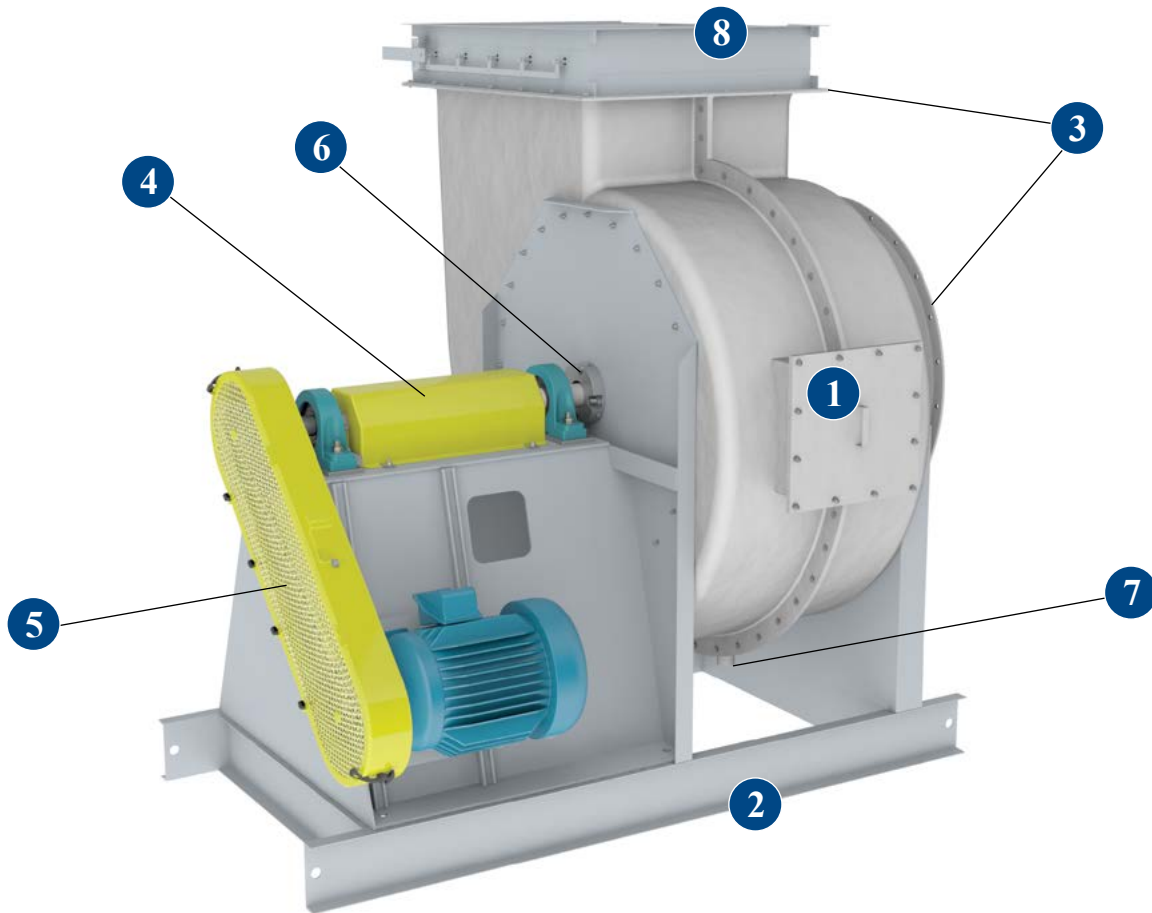

1 Bolted Access Doors Bolted access door allows for inspection and maintenance of internal fan components.

2 Unitary Base A structural steel base provides common support to fan, motor and drive including guards. This style of base is designed for use without isolators and requires adequate foundation integrity for proper operation.

3 Inlet/Outlet Flange Inlet and outlet flanges allow for duct mounting. Non-drilled outlet flanges are integrated into the housings as standard. Drilled bolt pattern is available. Inlet flange, drilled or undrilled, is bolted on in lieu of the standard inlet collar.

4 Shaft Guard (Exposed Bearings) Shaft guard is designed to allow access to the bearings and protect personnel from the moving drive parts. A shaft guard with bearings fully guarded is also available.

5 Quick Access Belt Guard Belt guard protects personnel from the moving drive parts. OSHA and quick access guards are available. Arrangement 10 offers a standard belt guard.

6 Shaft Seal, Double Lip-Type A double lip shaft seal significantly reduces leakage of the contaminated airstream. The optional double-lip type shaft seal utilizes either Viton[®] (fluoroelastomer) or Teflon[™] (fluoropolymer) seal element. The seal is positioned in fiberglass reinforced case and mounted to the housing. Double-lip shaft seals require a 316 stainless steel or Hastelloy[®] shaft sleeve or a solid 316 stainless steel shaft. Fiberglass shaft sleeves are not available for double-lip shaft seals. Consult Twin City Fan & Blower for shaft seal element chemical compatibility.

7 Housing Drain A fiberglass drain coupling mounted to the lowest point of the housing allows drainage of condensate from fan housing.

8 Opposed Blade Outlet Damper Outlet dampers add resistance to the fan by shifting the operating point to the left of the rating point. The horsepower savings depends on the relative position on the fan curve and is usually much less than other methods. Opposed blade dampers are recommended for systems where volume is modulated over the entire range. Opposed blade outlet dampers are available in epoxy coated mild steel or FRP.

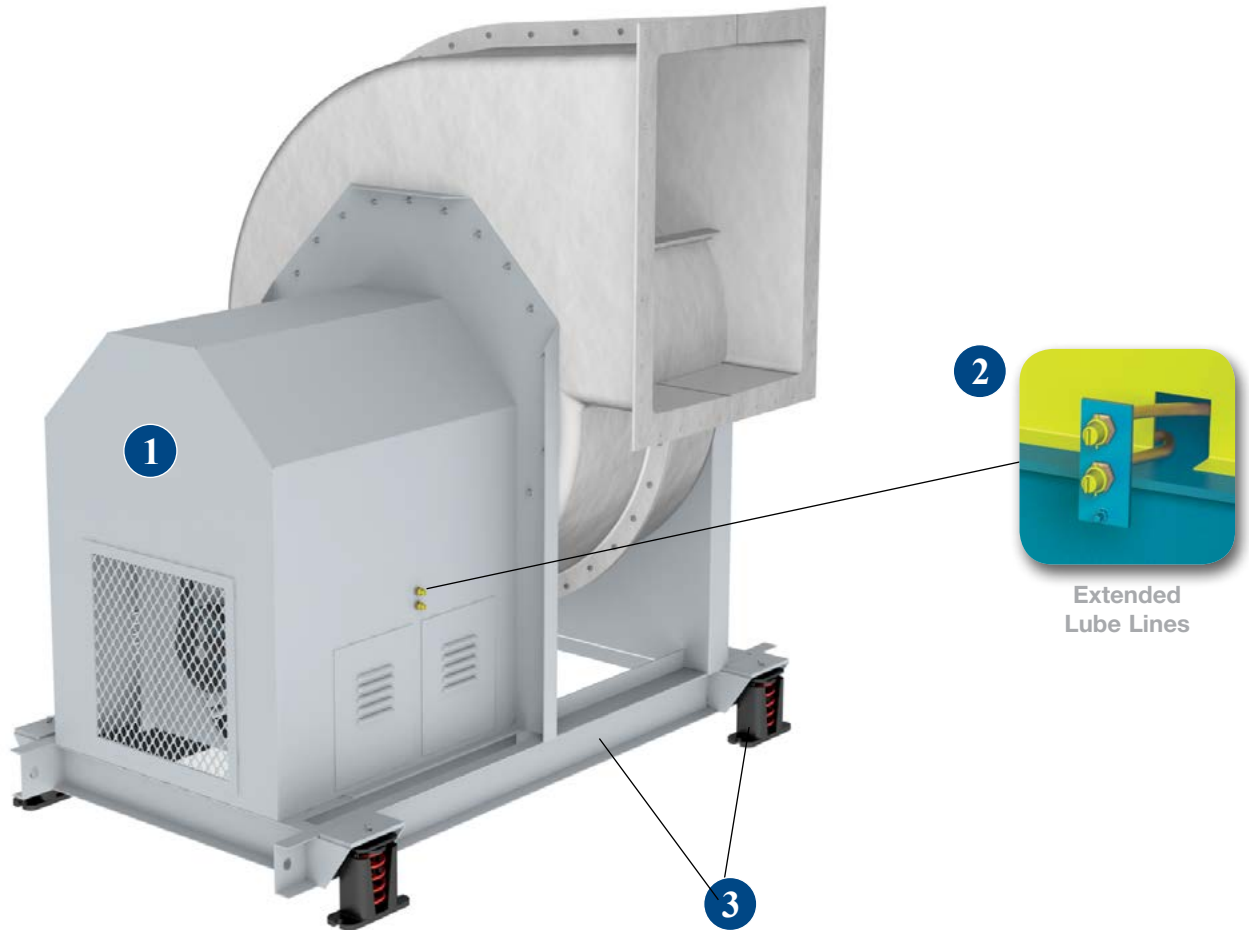

1 Weather Cover An easily removable weather cover is available for Arrangement 10 fans. The weather cover provides complete protection for the motor, fan bearings, and V-belt drive.

2 Extended Lube Lines Allow for easy lubrication of bearings on belt driven units without disassembly by extending polyethylene lines from fan bearings to exterior of base.

3 Isolation Base w/ Spring Isolator A structural steel base minimize the transmission of sound vibration from the fan to the building structure and provides common support to fan, motor and drive including guards. This style of base is designed for use with isolators and requires adequate foundation integrity for proper operation.

Other Options/Accessories Include:

- Detached Inlet Box
- Inlet Box Drain
- Inlet Box Access Door
- Inertia Base
- Parallel-Blade Outlet Damper
- Extended Life Bearings
- Shaft/Bearing Guard
- 316 Stainless Steel Shaft (No Sleeve)
- Stainless Steel Nameplate

Table 1. Maximum RPM, Wheel Weights, and WR² (moment of inertia in lb-ft²)

FAN SIZE	M1						M2					
	CLASS FG			CLASS CF			CLASS FG			CLASS CF		
	MAX. RPM	WEIGHT (LB)	WR ² (LB-FT ²)	MAX. RPM	WEIGHT (LB)	WR ² (LB-FT ²)	MAX. RPM	WEIGHT (LB)	WR ² (LB-FT ²)	MAX. RPM	WEIGHT (LB)	WR ² (LB-FT ²)
165	4208	22	4	4836	18	4	4765	24	6	5732	20	4
182	3766	42	8	4353	36	6	4265	42	8	5158	38	6
200	3405	44	10	3955	38	8	3856	46	12	4687	38	8
222	3028	68	20	3537	60	14	3429	70	20	4192	62	16
245	2724	74	26	3199	62	18	3084	76	26	3791	64	20
270	2448	84	38	2890	70	26	2772	88	42	3425	72	30
300	2180	94	56	2588	76	38	2469	100	60	3067	80	42
330	1963	125	88	2342	98	60	2223	135	96	2776	105	66
365	1737	160	140	2097	130	92	1967	165	150	2485	135	100
402	1543	185	210	1884	145	140	1747	195	220	2233	150	150
445	1366	300	370	1687	240	260	1547	310	400	1999	250	280
490	1215	340	540	1518	265	360	1376	355	580	1816	275	390
542	1074	485	960	1350	385	650	1217	505	1030	1600	395	700
600	951	545	1360	1215	420	890	1077	570	1470	1440	440	980

FAN SIZE	H1						H2					
	CLASS FG			CLASS CF			CLASS FG			CLASS CF		
	MAX. RPM	WEIGHT (LB)	WR ² (LB-FT ²)	MAX. RPM	WEIGHT (LB)	WR ² (LB-FT ²)	MAX. RPM	WEIGHT (LB)	WR ² (LB-FT ²)	MAX. RPM	WEIGHT (LB)	WR ² (LB-FT ²)
165	4579	22	4	5424	18	4	5260	22	4	6110	20	4
182	4098	40	8	4882	36	6	4708	42	8	5498	36	6
200	3706	42	10	4435	38	8	4257	44	10	4996	38	8
222	3295	66	18	3967	58	14	3785	70	20	4469	60	14
245	2964	72	24	3587	62	18	3405	74	26	4041	64	18
270	2664	84	36	3241	68	26	3060	88	40	3650	72	28
300	2372	92	52	2902	74	36	2725	98	58	3269	78	40
330	2136	125	84	2627	96	56	2454	130	92	2959	105	62
365	1890	155	130	2352	125	86	2171	165	150	2649	130	96
402	1679	180	200	2113	140	130	1928	190	210	2380	150	140
445	1487	295	360	1892	235	250	1708	305	390	2131	245	270
490	1323	330	520	1702	260	350	1519	345	560	1917	270	380
542	1169	480	930	1515	380	630	1343	495	990	1706	390	680
600	1035	535	1310	1363	410	860	1189	565	1430	1535	435	1260

Table 2. Shaft and Bearing Data

FAN SIZE	DESIGN	ARRANGEMENT 1		ARRANGEMENT 9 & 9F		ARRANGEMENT 10		ARRANGEMENT 8			
		SHAFT DIAMETER	BEARINGS	SHAFT DIAMETER	BEARINGS	SHAFT DIAMETER	BEARINGS	RPM	MOTOR HP	SHAFT DIAMETER	BEARINGS
165	M1 & M2	1.938	HDB	1.938	HDB	1.688	HDB	3550	15	1.938	HDB
	H1 & H2	1.938	HDB	1.938	HDB	1.688	HDB	3550	10	1.938	HDB
182	M1 & M2	2.188	HDB	2.188	HDB	1.938	HDB	3550	20	2.188	HDB
	H1 & H2	2.188	HDB	2.188	HDB	1.938	HDB	3550	15	2.188	HDB
200	M1 & M2	2.188	RB	2.188	RB	1.938	RB	3550	30	2.188	HDB
	H1 & H2	2.188	RB	2.438	HDB	1.938	RB	3550	25	2.188	HDB
222	M1 & M2	2.438	HDB	2.438	RB	2.188	RB	1775	7.5	2.438	HDB
	H1 & H2	2.438	RB	2.688	HDB	2.188	RB	3550	40	2.438	HDB
245	M1 & M2	2.438	HDB	2.438	RB	2.188	RB	1775	15	2.438	HDB
	H1 & H2	2.688	RB	2.688	RB	2.188	RB	1775	75	2.688	HDB
270	M1 & M2	2.688	RB	2.688	RB	2.188	RB	1775	20	2.688	HDB
	H1 & H2	2.938	RB	2.938	RB	2.188	RB	1775	15	2.938	HDB
300	M1 & M2	2.688	RB	2.688	RB	2.188	RB	1775	40	2.688	HDB
	H1 & H2	2.938	RB	2.938	RB	2.438	RB	1775	25	2.938	HDB
330	M1 & M2	2.938	RB	2.938	RB	2.438	RB	1775	60	2.938	HDB
	H1 & H2	2.938	RB	2.938	RB	2.438	RB	1775	40	2.938	HDB
365	M1 & M2	3.438	RB	3.438	RB	2.438	RB	1775	100	3.438	HDB
	H1 & H2	3.438	RB	3.438	RB	2.688	RB	1775	60	3.438	HDB
402	M1 & M2	3.438	RB	3.438	RB	—	—	1775	150	3.438	HDB
	H1 & H2	3.438	RB	3.438	RB	—	—	1775	100	3.438	HDB
445	M1 & M2	3.938	RB	3.938	RB	—	—	1180	75	3.938	HDB
	H1 & H2	3.938	RB	3.938	RB	—	—	1775	200	3.938	HDB
490	M1 & M2	3.938	RB	3.938	RB	—	—	1180	125	3.938	HDB
	H1 & H2	3.938	RB	3.938	RB	—	—	1775	300	3.938	HDB
542	M1 & M2	4.438	RB	4.438	RB	—	—	1180	200	3.938	HDB
	H1 & H2	4.438	RB	4.438	RB	—	—	1180	150	3.938	HDB
600	M1 & M2	4.938	RB	4.938	RB	—	—	1180	300	3.938	RB
	H1 & H2	4.938	RB	4.938	RB	—	—	1180	250	3.938	RB

NOTES:

HDB = Heavy Duty Ball Bearing
 RB = Unit Roller Bearing

Table 3. Bare Fan Weights (lb)

FAN SIZE	M1										M2									
	CLASS FG					CLASS CF					CLASS FG					CLASS CF				
	ARR. 1	ARR. 8	ARR. 9	ARR. 9F	ARR. 10	ARR. 1	ARR. 8	ARR. 9	ARR. 9F	ARR. 10	ARR. 1	ARR. 8	ARR. 9	ARR. 9F	ARR. 10	ARR. 1	ARR. 8	ARR. 9	ARR. 9F	ARR. 10
165	265	354	350	344	280	249	332	334	328	264	266	355	351	345	281	250	334	335	329	265
182	334	446	451	434	361	314	419	431	414	341	335	447	452	435	362	315	420	432	415	342
200	344	459	442	439	365	321	428	419	416	342	346	462	444	441	367	322	430	420	417	343
222	430	574	542	537	437	401	535	513	508	408	432	576	544	539	439	403	538	515	510	410
245	482	643	574	587	477	448	598	540	553	443	485	647	577	590	480	450	600	542	555	445
270	565	754	680	714	541	521	695	636	670	497	569	759	684	718	545	524	699	639	673	500
300	654	872	762	773	632	602	803	710	721	580	659	879	767	778	637	606	808	714	725	584
330	787	1050	940	953	778	722	963	875	888	713	793	1058	946	959	784	727	970	880	893	718
365	1036	1382	1291	1305	881	958	1278	1213	1227	803	1043	1391	1298	1312	888	963	1284	1218	1232	808
402	1596	2128	1958	1921	—	1513	2018	1875	1838	—	1605	2140	1967	1930	—	1520	2027	1882	1845	—
445	2098	2798	2370	2337	—	1987	2650	2259	2226	—	2109	2812	2381	2348	—	1996	2662	2268	2235	—
490	2350	3134	2559	2582	—	2215	2954	2424	2447	—	2364	3152	2573	2596	—	2226	2968	2435	2458	—
542	2875	3834	3004	3084	—	2700	3600	2829	2909	—	2892	3856	3021	3101	—	2713	3618	2842	2922	—
600	3451	4602	3579	3662	—	3239	4319	3367	3450	—	3477	4636	3605	3688	—	3259	4346	3387	3470	—

FAN SIZE	H1										H2									
	CLASS FG					CLASS CF					CLASS FG					CLASS CF				
	ARR. 1	ARR. 8	ARR. 9	ARR. 9F	ARR. 10	ARR. 1	ARR. 8	ARR. 9	ARR. 9F	ARR. 10	ARR. 1	ARR. 8	ARR. 9	ARR. 9F	ARR. 10	ARR. 1	ARR. 8	ARR. 9	ARR. 9F	ARR. 10
165	262	350	347	341	277	247	330	332	326	262	263	351	348	342	278	248	331	333	327	263
182	330	440	447	430	357	311	415	428	411	338	331	442	448	431	358	312	416	429	412	339
200	340	454	438	435	361	319	426	417	414	340	342	456	440	437	363	320	427	418	415	341
222	425	567	537	532	432	397	530	509	504	404	427	570	539	534	434	399	532	511	506	406
245	476	635	568	581	471	444	592	536	549	439	479	639	571	584	474	446	595	538	551	441
270	559	746	674	708	535	516	688	631	665	492	563	751	678	712	539	519	692	634	668	495
300	646	862	754	765	624	595	794	703	714	573	651	868	759	770	629	599	799	707	718	577
330	776	1035	929	942	767	714	952	867	880	705	782	1043	935	948	773	719	959	872	885	710
365	1024	1366	1279	1293	869	949	1266	1204	1218	794	1031	1375	1286	1300	876	954	1272	1209	1223	799
402	1583	2111	1945	1908	—	1503	2004	1865	1828	—	1592	2123	1954	1917	—	1510	2014	1872	1835	—
445	2082	2776	2354	2321	—	1974	2632	2246	2213	—	2093	2791	2365	2332	—	1983	2644	2255	2222	—
490	2330	3107	2539	2562	—	2199	2932	2408	2431	—	2344	3126	2553	2576	—	2210	2947	2419	2442	—
542	2852	3803	2981	3061	—	2682	3576	2811	2891	—	2869	3826	2998	3078	—	2695	3594	2824	2904	—
600	3423	4564	3551	3634	—	3216	4288	3344	3427	—	3449	4599	3577	3660	—	3236	4315	3364	3447	—



CORROSIVE ATMOSPHERE GUIDE

CORROSIVE AGENT	STANDARD CONSTRUCTION (°F)	ALL VINYLESTER AIRSTREAM (°F)
Acetaldehyde	120 (Fumes Only)	120 (Fumes Only)
Acetic Acid to 10%	180	210
Acetic Acid to 50%	90	180
Acetic Acid to 100%	Not Recommended	Not Recommended
Acetic Acid, Glacial	Not Recommended	Not Recommended
Acetic Acid: HCl	Recommended	Recommended
Acetic Anhydride	Not Recommended	Not Recommended
Acetic: H ₂ O ₂ (Peracetic Acid)	Recommended	Recommended
Acetone to 10%	Not Recommended	180
Acetyl Chloride	Not Recommended	Recommended
Acrylic Acid to 25%	Consult Factory	100
Acrylonitrile (20%)	Not Recommended	100 ²
Aluminum Chloride	*120	*210
Aluminum Fluoride	No Data	80 (Veil Recommended)
Aluminum Potassium Sulfate	160	210
Aluminum Sulfate	240	210
Ammonia, Dry to 100%	Consult Factory	100
Ammonia, Vapors to 40%	Consult Factory	180
Ammonium Bicarbonate to 50%	140	160
Ammonium Carbonate	120	150
Ammonium Chloride	*200	*210
Ammonium Hydroxide to 5%	90 (Veil Recommended)	180 (Veil Recommended)
Ammonium Hydroxide to 10%	90 (Veil Recommended)	150 (Veil Recommended)
Ammonium Hydroxide to 29%	Consult Factory	100 (Veil Recommended)
Ammonium Nitrate	200	220
Ammonium Persulfate	150	180
Ammonium Phosphate	150	210
Ammonium Sulfate	200	220
Ammonium Sulfite	Consult Factory	150
Amyl Acetate	Consult Factory	Consult Factory
Amyl Alcohol	Consult Factory	120
Aniline to 20%	Consult Factory	100
Aniline Sulfate to 25%	150	210
Antimony Pentachloride	Consult Factory	100
Arsenious Acid	Consult Factory	180
Barium Carbonate	180 (Veil Recommended)	180
Barium Chloride	200	210
Barium Hydroxide to 10%	Consult Factory	150
Barium Sulfide	Consult Factory	180
Benzaldehyde	Not Recommended	Not Recommended
Benzene	Not Recommended	Not Recommended
Benzene Sulfonic Acid to 25%	Consult Factory	150
Benzoic Acid	Consult Factory	210
Benzyl Alcohol	Not Recommended	Not Recommended
Benzyl Chloride	Not Recommended	Not Recommended
Boric Acid	180	210
Bromine, Dry Gas	Recommended	100
Bromine, Moist Gas	Recommended	100
Butyl Alcohol	Consult Factory	120
Butylene Oxide	Not Recommended	Not Recommended
Butyric Acid to 50%	150	210
Butyric Acid up to 50%	Consult Factory	80
Calcium Chlorate	180	220
Calcium Chloride	240	210
Calcium Hydroxide to 15%	No Data, Veil Recommended	180 (Veil Recommended)
Calcium Hypochlorite	Consult Factory	Consult Factory
Calcium Sulfate	*200	*210

CORROSIVE AGENT	STANDARD CONSTRUCTION (°F)	ALL VINYLESTER AIRSTREAM (°F)
Carbon Dioxide	250	250
Carbon Disulfide	Not Recommended	Not Recommended
Carbon Monoxide	200	250
Carbon Tetrachloride	Consult Factory	150
Carbonic Acid	Not Recommended	Not Recommended
Chlorinated Brine, pH>9 (Hypochlorite), Cl ₂ Sat'd	Consult Factory	180 (Double Veil Recommended)
Chlorine Dioxide	Consult Factory	Consult Factory
Chlorine Gas, Dry	Consult Factory	Consult Factory
Chlorine Gas, Wet	Consult Factory	Consult Factory
Chlorine Water	*125	*200
Chloroacetic Acid to 25%	Consult Factory	*120
Chloroacetic Acid 25% to 50%	Consult Factory	*100
Chlorobenzene	Not Recommended	Not Recommended
Chloroform	Not Recommended	Fumes Only
Chlorosulfonic Acid	Not Recommended	Not Recommended
Chlorotoluene	Not Recommended	80° (Fumes Only)
Chrome-Plating Bath	Consult Factory	Recommended
Chromic Acid to 20%	Consult Factory	150
Chromic Acid + Sulfuric	Recommended	Recommended
Citric Acid	Recommended	210
Copper Chloride	*220	*220
Copper Cyanide	Consult Factory	210
Copper Nitrate	Recommended	210
Copper Sulfate	Recommended	210
Cyclohexane	Consult Factory	120
Dichlorobenzene	Not Recommended	Not Recommended
Dichloroethylene	Not Recommended	Not Recommended
Dichlorophenoxyacetic Acid	Consult Factory	120
Dichloropropane	Not Recommended	Not Recommended
Dichlorotoluene	Not Recommended	120
Diesel Fuel	Recommended	180
Diethyl Ether	Not Recommended	Not Recommended
Diethyl Ketone	Not Recommended	Not Recommended
Diethylbenzene	No Data	100
Diisobutyl Ketone	Not Recommended	Not Recommended
Diisobutylene	No Data	100
Dimethyl Sulfide	Not Recommended	Not Recommended
Dimethyl Sulfoxide to 20%	Consult Factory	100 (Fumes Only)
Dimethylformamide	Not Recommended	Not Recommended
Dipropylene Glycol	Consult Factory	180
Dodecene	Not Recommended	150
Dodecylbenzenesulfonic Acid: H ₂ SO ₄ : H ₂ O: Oil	Consult Factory	200
Esters, Fatty Acid	Recommended	180
Ethyl Acetate	Not Recommended	Consult Factory
Ethyl Acrylate	Not Recommended	Not Recommended
Ethyl Alcohol	Consult Factory	Consult Factory
Ethyl Benzene	Not Recommended	80
Ethyl Chloride	Not Recommended	Not Recommended
Ethyl Ether	Not Recommended	Not Recommended
Ethylene Chlorohydrin	Consult Factory	120
Ethylene Dibromide	Not Recommended	Not Recommended
Ethylene Dichloride	Not Recommended	Not Recommended
Ethylene Glycol	210	210
Ethylene Oxide	Not Recommended	Not Recommended
Ethylenediamine Tetra Acetic Acid	Not Recommended	120
Ferric Chloride	*220	*210
Ferric Nitrate	170	210
Ferric Sulfate	200	210
Ferrous Chloride	Consult Factory	*210

No Data = No data has been collected for corrosive agent; Consult factory.

* = Special Shaft and hardware required; Consult factory.

Agents without a temperature limit assume ambient (70 °F) conditions. If higher temperatures are required, consult factory.

Concentration levels are by weight unless otherwise stated.

CORROSIVE AGENT	STANDARD CONSTRUCTION (°F)	ALL VINYLESTER AIRSTREAM (°F)
Ferrous Nitrate	160	210
Ferrous Sulfate	Consult Factory	210
Flue Gas, (wet)	Consult Factory	180
Fluoboric Acid	*90 (Double Veil Recommended)	210 (Double Veil Recommended)
Fluorine Gas	Not Recommended	120 (Double Veil Recommended)
Fluosilicic Acid	Veil Recommended	Veil Recommended
Formaldehyde	Consult Factory	120
Formic Acid up to 10%	150	180
Fuel Oil	Consult Factory	180
Furfural to 10%	Consult Factory	100 (Fumes Only)
Gasoline, No Lead, No Methanol	Consult Factory	120
Gasoline, Aviation	Consult Factory	180
Glycerine	200	210
Glycolic Acid	Consult Factory	100
Heptane	120	210
Hexachloroethane	Not Recommended	Not Recommended
Hexamethylenetetramine to 40%	Consult Factory	100
Hexane	Consult Factory	160
Hydrazine	Not Recommended	Not Recommended
Hydrobromic Acid to 25%	*160	*180
Hydrochloric Acid	Consult Factory	Consult Factory
Hydrocyanic Acid to 10%	170	210
Hydrofluoric Acid to 10%	*100 (Double Veil Recommended)	*150 (Double Veil Recommended)
Hydrogen	Recommended	Recommended
Hydrogen Bromide, Dry	Recommended	180
Hydrogen Chloride	Consult Factory	Consult Factory
Hydrogen Fluoride, Vapor	*90 Veil Recommended)	*180 (Veil Recommended)
Hydrogen Peroxide to 30%	100	150
Hydrogen Sulfide to 5%	Consult Factory	Consult Factory
Hydroxyacetic Acid	Consult Factory	100
Hypochlorous Acid to 10%	90	100
Iodine Vapor	Consult Factory	150
Isobutyl Alcohol to 20%	No Data	150
Isopropyl Alcohol	No Data	120
Isopropyl Amine	No Data	100
Kerosene	120	180
Lactic Acid	Consult Factory	*210
Lead Acetate	160	210
Linseed Oil	Consult Factory	210
Lithium Carbonate	Not Recommended	180 (Veil Recommended)
Lithium Chloride	Consult Factory	180
Lithium Hydroxide	Not Recommended	180 (Veil Recommended)
Lithium Hypochlorite	Consult Factory	Consult Factory
Magnesium Carbonate	160	180
Magnesium Chloride	Consult Factory	210
Magnesium Hydroxide	Consult Factory	210
Magnesium Sulfate	200	210
Maleic Acid	170	180
Mercapto Acetic Acid	Not Recommended	Not Recommended
Mercuric Chloride	*210	*210
Mercurous Chloride	210	210
Mercury	Consult Factory	210
Methacrylic Acid to 25%	Consult Factory	100
Methyl Alcohol to 5%	Consult Factory	20 (Fumes Only)
Methyl Bromide to 10%	Consult Factory	80 (Fumes Only)
Methyl Chloride	Consult Factory	Consult Factory
Methyl Ethyl Ketone	Not Recommended	Not Recommended
Methylene Chloride	Not Recommended	Not Recommended
Mineral Oil, Aliphatic	Recommended	210

CORROSIVE AGENT	STANDARD CONSTRUCTION (°F)	ALL VINYLESTER AIRSTREAM (°F)
Monochloroacetic Acid	Consult Factory	120 (Fumes Only)
Monochlorobenzene	Not Recommended	Not Recommended
Monoethanolamine	Not Recommended	Not Recommended
Naphtha	180	180
Naphthalene	130	210
Nickel Chloride	220	210
Nickel Nitrate	220	210
Nickel Sulfate	220	210
Nitric Acid to 5%	170	150
Nitric Acid 5% to 20%	Consult Factory	120
Nitrobenzene	Not Recommended	Not Recommended
Nitrogen	Recommended	Recommended
Oleic Acid	200	210
Oleum	Not Recommended	Not Recommended
Olive Oil	Recommended	Recommended
Oxalic Acid	Consult Factory	120
Ozone	Consult Factory	Consult Factory
Palmitic Acid	Consult Factory	Consult Factory
Perchloric Acid to 10%	Consult Factory	150 (Fumes Only)
Perchloroethylene	Consult Factory	80
Phenol (Carbolic Acid)	Not Recommended	Not Recommended
Phenol Sulfonic Acid	Not Recommended	Not Recommended
Phosphoric Acid	*210 (Veil Recommended)	*210 (Veil Recommended)
Phosphorous Acid to 70%	Consult Factory	180
Phosphorous Oxichloride	NR	No Data
Phosphorous Trichloride	NR	No Data
Phthalic Acid	Consult Factory	210
Phthalic Anhydride	*150	*210
Picric Acid (Alcoholic)	Not Recommended	Not Recommended
Polyvinyl Acetate Emulsions	Consult Factory	120
Polyvinyl Alcohol	Consult Factory	180
Potassium Bicarbonate to 10%	Consult Factory	150 (Veil Recommended)
Potassium Carbonate to 10%	Consult Factory	150 (Double Veil Recommended)
Potassium Chloride	200	210
Potassium Cyanide	Consult Factory	Consult Factory
Potassium Dichromate	200	210
Potassium Ferricyanide	200	210
Potassium Hydroxide to 25%	Consult Factory	150 (Double Veil Recommended)
Potassium Nitrate	200	210
Potassium Permanganate	150	210
Potassium Persulfate	90	210
Potassium Sulfate	200	210
Propionic Acid to 50%	Consult Factory	180
Propionyl Chloride	Not Recommended	Not Recommended
Propylene Glycol	Recommended	210
Pulp and Paper Mill Blow Down Gases	Consult Factory	Consult Factory
Pyridine	Not Recommended	Not Recommended
Rayon Spin Bath (Fumes)	Consult Factory	140
Selenious Acid	No Data	210
Silver Nitrate	200	210
Sodium Acetate	150	210
Sodium Benzoate	Consult Factory	180
Sodium Bicarbonate to 10%	140 (Veil Recommended)	180 (Veil Recommended)
Sodium Bisulfate	200	210
Sodium Borate	Consult Factory	210
Sodium Bromide	Consult Factory	210
Sodium Carbonate to 35%	Consult Factory	180 (Veil Recommended)
Sodium Chlorate	90	210

No Data = No data has been collected for corrosive agent; Consult factory.

* = Special Shaft and hardware required; Consult factory.

Agents without a temperature limit assume ambient (70 °F) conditions. If higher temperatures are required, consult factory.

Concentration levels are by weight unless otherwise stated.

CORROSIVE ATMOSPHERE GUIDE

CORROSIVE AGENT	STANDARD CONSTRUCTION (°F)	ALL VINYLESTER AIRSTREAM (°F)
Sodium Chloride	200	210
Sodium Chlorite	Consult Factory	Consult Factory
Sodium Cyanide	100	210
Sodium Dichromate	160	210
Sodium Ferricyanide	Consult Factory	210
Sodium Flouride	Consult Factory	180 (Veil Recommended)
Sodium Hydroxide	Consult Factory	180 (Veil Recommended)
Sodium Hypochlorite pH>11 (active Chlorine) to 18%	Consult Factory	180 (Double Veil Recommended)
Sodium Hypochlorite (active Chlorine) 18% to 21%	Consult Factory	100 (Double Veil Recommended)
Sodium Hypochlorite (active Chlorine) >18%	Not Recommended	Not Recommended
Sodium Nitrate	Consult Factory	210
Sodium Nitrite	Consult Factory	210
Sodium Silicate	Consult Factory	210
Sodium Sulfate	180	210
Sodium Sulfide	90	210
Sodium Sulfite	Consult Factory	210
Sodium Tetraborate	180	180
Sodium Tripolyphosphate	125	210
Sodium Xylenesulfonate	Recommended	Recommended
Sorbitol Solutions	Consult Factory	160
Stannic Chloride	*180	*210
Stannous Chloride	*200	*210
Stannous Fluoride: Hydro-fluoric Acid	Not Recommended	120 (Veil Recommended)
Steam Vapor	180	180
Stearic Acid	200	210
Styrene	Not Recommended	Not Recommended
Sulfamic Acid to 25%	150	150
Sulfate Liquors	Consult Factory	200
Sulfonated Detergents	Consult Factory	160
Sulfite Liquors	Consult Factory	200
Sulfur Dioxide, Dry	Consult Factory	210
Sulfur Dioxide, Wet	Consult Factory	180
Sulfur Trioxide, Dry	Consult Factory	210
Sulfur Trioxide, Wet	Consult Factory	210
Sulfur, Wetttable, Fungicide	Consult Factory	180
Sulfuric Acid to 25%	Consult Factory	*210
Sulfuric Acid to 50%	Consult Factory	*180

CORROSIVE AGENT	STANDARD CONSTRUCTION (°F)	ALL VINYLESTER AIRSTREAM (°F)
Sulfuric Acid to 70%	Consult Factory	*100
Sulfuric Acid to 80%	Consult Factory	Not Recommended
Sulfuric: Nitric Acids	Consult Factory	150
Sulfuric Acid/Phosphoric Acid to 25%/to 25%	Consult Factory	180
Sulfurous Acid to 10%	90	120
Tannic Acid	200	210
Tartaric Acid	210	210
Tetrachloroethane	No Data	100 (Fumes Only)
Tetrachloroethylene (perchloroethylene)	Consult Factory	80
Tetrachloropyridine	Consult Factory	80
Tetrapotassium Pyrophosphate to 60%	Consult Factory	130
Thionyl Chloride	Not Recommended	Not Recommended
Toluene	Consult Factory	80
Toluene Sulfonic Acid	Consult Factory	200
Trichloroethane	Not Recommended	100
Trichloroethylene	Not Recommended	Not Recommended
Trichloromonofluoromethane (FREON II)	Consult Factory	80
Trichoroacetic Acid to 50%	Consult Factory	*100
Triethanolamine	Consult Factory	120
Trimethylene Chlorobromide	Not Recommended	Not Recommended
Trisodium Phosphate to 50%	Consult Factory	210
Turpentine	Not Recommended	150
Urea to 50%	90	160
Urea-Ammonium-Nitrate	Consult Factory	Consult Factory
Vinegar	Recommended	210
Vinyl Chloride	Not Recommended	Not Recommended
Vinyltoluene	No Data	Recommended ³
Waste, Organic (H ₂ O-HCl, Cl ₂ Vapors)	Consult Factory	Consult Factory
Water, Deionized	180	180
Water, Demineralized	180	180
Water, Distilled	180	180
Water, Sea	180	180
Water, Steam Condensate	180	180
Xylene	Consult Factory	80
Zinc Chloride	200	*210
Zinc Hydrosulfite	Consult Factory	Consult Factory
Zinc Nitrate	180	210

No Data = No data has been collected for corrosive agent; Consult factory.

* = Special Shaft and hardware required; Consult factory.

Agents without a temperature limit assume ambient (70 °F) conditions. If higher temperatures are required, consult factory.

Concentration levels are by weight unless otherwise stated.



165 M1

Outlet Area: 1.57 ft²
Wheel Dia.: 16.50"

Class FG Max. RPM: 4000
Class CF Max. RPM: 4000

Tip Speed (FPM) = 4.32 x RPM
Fan Efficiency Grade: FEG 80

CFM	OV	4" SP		5" SP		6" SP		7" SP		8" SP		8" SP		9" SP		10" SP		11" SP	
		RPM	BHP	RPM	BHP	RPM	BHP	RPM	BHP	RPM	BHP	RPM	BHP	RPM	BHP	RPM	BHP	RPM	BHP
2000	1274	2060	2.05																
2500	1592	2116	2.32	2319	2.98	2523	3.78												
3000	1911	2226	2.77	2405	3.45	2578	4.17	2747	4.97	2916	5.88	3085	6.90						
3500	2229	2364	3.34	2525	4.06	2681	4.83	2832	5.63	2980	6.47	3125	7.37	3270	8.36	3415	9.45	3559	10.63
4000	2548	2510	3.97	2667	4.80	2810	5.61	2947	6.45	3083	7.34	<u>3215</u>	<u>8.26</u>	3345	9.21	3472	10.20	3598	11.25
4500	2866	2665	4.69	2813	5.59	2954	6.52	3084	7.43	3209	8.36	3330	9.32	<u>3449</u>	<u>10.30</u>	<u>3567</u>	<u>11.33</u>	<u>3683</u>	<u>12.37</u>
5000	3185	2838	5.57	2968	6.49	3101	7.49	3230	8.52	3350	9.53	3464	10.54	3575	11.58	3683	12.63	<u>3791</u>	<u>13.72</u>
5500	3503	3025	6.63	3138	7.55	3257	8.58	3377	9.66	3496	10.79	3608	11.91	3715	13.02	3818	14.14	3918	15.27
6000	3822	3221	7.87	3323	8.83	3427	9.86	3535	10.96	3645	12.13	3754	13.34	3860	14.57	3961	15.79		
6500	4140	3421	9.28	3516	10.30	3610	11.36	3706	12.47	3804	13.65	3906	14.91						
7000	4459	3624	10.86	3715	11.98	3802	13.08	3889	14.22	3977	15.40								
7500	4777	3829	12.63	3916	13.84	3999	15.02												

165 M2

Outlet Area: 1.57 ft²
Wheel Dia.: 16.50"

Class FG Max. RPM: 4000
Class CF Max. RPM: 4000

Tip Speed (FPM) = 4.32 x RPM
Fan Efficiency Grade: FEG 75

CFM	OV	4" SP		5" SP		6" SP		7" SP		8" SP		8" SP		9" SP		10" SP		11" SP	
		RPM	BHP	RPM	BHP	RPM	BHP	RPM	BHP	RPM	BHP	RPM	BHP	RPM	BHP	RPM	BHP	RPM	BHP
2000	1274																		
2500	1592	2180	2.45	2381	3.12	2580	3.91												
3000	1911	2305	2.97	2483	3.67	2654	4.41	2821	5.21	2986	6.10								
3500	2229	2457	3.60	2618	4.36	2772	5.15	2923	5.98	3069	6.85	3213	7.76	3354	8.73	3496	9.80	3638	10.97
4000	2548	2614	4.29	2772	5.17	2917	6.03	3054	6.91	3187	7.83	<u>3318</u>	<u>8.78</u>	<u>3447</u>	<u>9.76</u>	3573	10.77	3698	11.83
4500	2866	2785	5.11	2930	6.04	3072	7.03	3204	8.00	3329	8.98	3449	9.97	3567	10.99	<u>3684</u>	<u>12.06</u>	<u>3799</u>	<u>13.14</u>
5000	3185	2976	6.12	3101	7.06	3230	8.09	3359	9.17	3482	10.27	3597	11.34	3708	12.42	3816	13.53	3922	14.65
5500	3503	3180	7.33	3290	8.30	3403	9.34	3520	10.46	3638	11.64	3752	12.83	3861	14.03	3964	15.20		
6000	3822	3391	8.74	3491	9.75	3591	10.81	3695	11.94	3801	13.14	3909	14.41						
6500	4140	3606	10.34	3700	11.43	3792	12.54	3884	13.68	3979	14.89								
7000	4459	3823	12.14	3913	13.33	4000	14.51												
7500	4777																		

165 H1

Outlet Area: 1.41 ft²
Wheel Dia.: 16.50"

Class FG Max. RPM: 4000
Class CF Max. RPM: 4000

Tip Speed (FPM) = 4.32 x RPM
Fan Efficiency Grade: FEG 80

CFM	OV	6" SP		7" SP		8" SP		9" SP		10" SP		11" SP		12" SP		13" SP		14" SP	
		RPM	BHP	RPM	BHP	RPM	BHP	RPM	BHP	RPM	BHP	RPM	BHP	RPM	BHP	RPM	BHP	RPM	BHP
2000	1418	2578	3.01																
2300	1631	2618	3.24	2796	3.89	2975	4.64												
2600	1844	2690	3.61	2851	4.23	3010	4.91	3167	5.66	3325	6.49	3480	7.39						
2900	2057	2780	4.04	2930	4.69	3076	5.37	3219	6.08	3361	6.84	3501	7.66	3643	8.57	3784	9.55		
3200	2270	2884	4.53	3023	5.20	<u>3160</u>	<u>5.91</u>	<u>3294</u>	<u>6.65</u>	3426	7.40	3555	8.19	3683	9.03	3810	9.92	3937	10.88
3500	2482	2996	5.08	3130	5.80	3257	6.52	3382	7.28	<u>3506</u>	<u>8.07</u>	<u>3628</u>	<u>8.87</u>	3748	9.70	3866	10.56	3982	11.46
3800	2695	3110	5.66	3242	6.44	3366	7.22	3484	8.00	3600	8.80	<u>3714</u>	<u>9.63</u>	<u>3828</u>	<u>10.50</u>	<u>3939</u>	<u>11.37</u>		
4100	2908	3226	6.27	3355	7.11	3478	7.95	3594	8.79	3704	9.63	3812	10.48	<u>3919</u>	<u>11.36</u>				
4400	3121	3349	6.95	3471	7.82	3591	8.72	3706	9.63	3815	10.52	3919	11.42						
4700	3333	3481	7.72	3593	8.61	3707	9.54	3820	10.50	3928	11.46								
5000	3546	3622	8.61	3723	9.48	3828	10.42	3935	11.41										
5300	3759	3769	9.59	3862	10.48	3958	11.42												

165 H2

Outlet Area: 1.41 ft²
Wheel Dia.: 16.50"

Class FG Max. RPM: 4000
Class CF Max. RPM: 4000

Tip Speed (FPM) = 4.32 x RPM
Fan Efficiency Grade: FEG 71

CFM	OV	6" SP		7" SP		8" SP		9" SP		10" SP		11" SP		12" SP		13" SP		14" SP	
		RPM	BHP	RPM	BHP	RPM	BHP	RPM	BHP	RPM	BHP	RPM	BHP	RPM	BHP	RPM	BHP	RPM	BHP
2000	1418	2638	3.12																
2300	1631	2693	3.42	2868	4.07	3042	4.79												
2600	1844	2777	3.84	2937	4.48	3094	5.17	3248	5.91	3402	6.73								
2900	2057	2879	4.32	3027	4.99	<u>3173</u>	<u>5.70</u>	3315	6.43	3454	7.20	3592	8.02	3730	8.90	3869	9.87		
3200	2270	2995	4.88	3133	5.58	3268	6.31	<u>3401</u>	<u>7.07</u>	<u>3532</u>	<u>7.86</u>	3660	8.66	3786	9.51	3911	10.39		
3500	2482	3115	5.47	3250	6.24	3378	7.00	3502	7.78	<u>3624</u>	<u>8.59</u>	<u>3745</u>	<u>9.44</u>	<u>3864</u>	<u>10.30</u>	3981	11.18		
3800	2695	3236	6.10	3371	6.94	3496	7.77	3615	8.59	3730	9.43	3843	10.29	<u>3955</u>	<u>11.17</u>				
4100	2908	3364	6.79	3492	7.67	3617	8.57	3734	9.46	3846	10.36	3954	11.25						
4400	3121	3500	7.57	3619	8.47	3738	9.41	3854	10.37	3965	11.33								
4700	3333	3647	8.47	3754	9.36	3865	10.33	3976	11.33										
5000	3546	3802	9.48	3899	10.38	4000	11.35												
5300	3759	3961	10.60																

Class FG (Fiberglass Wheel)

Class CF (Carbon Fiber Wheel)

- NOTES:
- Performance certified is for installation Type B: Free inlet, Ducted outlet.
 - Power rating (BHP) does not include transmission losses.
 - Performance ratings do not include the effects of appurtenances (accessories).
 - Underlined values indicate maximum static efficiency.

PERFORMANCE DATA

182 M1

Outlet Area: 1.92 ft²
Wheel Dia.: 18.25"

Class FG Max. RPM: 3766
Class CF Max. RPM: 4000

Tip Speed (FPM) = 4.78 x RPM
Fan Efficiency Grade: FEG 80

CFM	OV	4" SP		5" SP		6" SP		8" SP		10" SP		12" SP		14" SP		15" SP		16" SP	
		RPM	BHP	RPM	BHP	RPM	BHP	RPM	BHP	RPM	BHP	RPM	BHP	RPM	BHP	RPM	BHP	RPM	BHP
1800	938																		
2600	1354	1868	2.55																
3400	1771	1965	3.13	2135	3.93	2300	4.83	2629	7.04										
4200	2188	2120	3.99	2267	4.86	2410	5.79	2684	7.79	2951	10.14	3216	12.93						
5000	2604	2293	5.00	2434	6.03	2563	7.05	2805	9.18	3039	11.48	3264	13.96	3488	16.80	3600	18.37	3712	20.05
5800	3021	2483	6.23	2609	7.35	2735	8.54	2962	10.91	3171	13.32	3375	15.92	3572	18.62	3669	20.04	3766	21.53
6600	3438	2699	7.82	2804	8.95	2914	10.20	3133	12.87	3332	15.55	3517	18.26	3697	21.10	<u>3786</u>	<u>22.58</u>	<u>3874</u>	<u>24.08</u>
7400	3854	2929	9.78	3021	10.97	3114	12.22	3309	15.01	3503	18.02	<u>3681</u>	<u>21.00</u>	<u>3848</u>	<u>24.00</u>	3930	25.54		
8200	4271	3167	12.11	3251	13.40	3334	14.72	3502	17.54	3678	20.67	3853	24.00						
9000	4688	3409	14.82	3488	16.25	3564	17.67	3714	20.58	3868	23.74								
9800	5104	3653	17.91	3729	19.51	3801	21.07	3939	24.16										
10600	5521	<u>3901</u>	<u>21.47</u>	<u>3972</u>	<u>23.20</u>														

182 M2

Outlet Area: 1.92 ft²
Wheel Dia.: 18.25"

Class FG Max. RPM: 4000
Class CF Max. RPM: 4000

Tip Speed (FPM) = 4.78 x RPM
Fan Efficiency Grade: FEG 71

CFM	OV	4" SP		5" SP		6" SP		8" SP		10" SP		12" SP		14" SP		15" SP		16" SP	
		RPM	BHP	RPM	BHP	RPM	BHP	RPM	BHP	RPM	BHP	RPM	BHP	RPM	BHP	RPM	BHP	RPM	BHP
3000	1563	1962	2.95	2146	3.77														
3600	1875	2069	3.55	2232	4.40	2389	5.31	2695	7.40										
4200	2188	2202	4.29	2350	5.21	2490	6.16	2763	8.24	3024	10.55								
4800	2500	2341	5.11	2485	6.16	2616	7.20	2863	9.37	3102	11.73	3332	14.26	3559	17.14	3674	18.75		
5400	2813	2490	6.06	2624	7.20	2753	8.38	2986	10.72	3204	13.16	3417	15.78	3623	18.53	3724	19.98	3825	21.51
6000	3125	2657	7.23	2773	8.39	2893	9.64	3121	12.25	3327	14.85	3523	17.55	<u>3715</u>	<u>20.41</u>	<u>3809</u>	<u>21.87</u>	3902	23.37
6600	3438	2836	8.64	2937	9.81	3042	11.07	3259	13.87	3461	16.73	3647	19.59	3825	22.53	<u>3912</u>	<u>24.04</u>	<u>4000</u>	<u>25.62</u>
7200	3750	3021	10.27	3114	11.50	3207	12.79	3402	15.64	3598	18.73	3781	21.85	3950	24.93				
7800	4063	3211	12.14	3298	13.46	3383	14.79	3556	17.65	3738	20.85	3918	24.24						
8400	4375	3404	14.24	3486	15.66	3566	17.08	3723	20.00	3887	23.23								
9000	4688	3598	16.57	3678	18.13	3753	19.64	3899	22.68										
9600	5000	3794	19.17	3871	20.86	3943	22.48												

182 H1

Outlet Area: 1.74 ft²
Wheel Dia.: 18.25"

Class FG Max. RPM: 4000
Class CF Max. RPM: 4000

Tip Speed (FPM) = 4.78 x RPM
Fan Efficiency Grade: FEG 75

CFM	OV	6" SP		8" SP		10" SP		11" SP		12" SP		13" SP		14" SP		15" SP		16" SP	
		RPM	BHP	RPM	BHP	RPM	BHP	RPM	BHP	RPM	BHP	RPM	BHP	RPM	BHP	RPM	BHP	RPM	BHP
2500	1437	2334	3.72																
3000	1724	2398	4.18	2701	5.81														
3500	2011	2502	4.87	2772	6.48	3032	8.29	3161	9.31	3291	10.44	3420	11.64						
4000	2299	2631	5.70	2876	7.40	3113	9.24	3228	10.20	3342	11.22	3454	12.29	3567	13.44	3680	14.68	3793	16.00
4500	2586	2770	6.63	3003	8.48	3219	10.39	3325	11.40	3430	12.43	3533	13.49	3635	14.59	3735	15.71	3835	16.90
5000	2874	2912	7.64	3140	9.69	3345	11.74	3443	12.78	3539	13.85	3635	14.96	<u>3730</u>	<u>16.09</u>	<u>3823</u>	<u>17.23</u>	<u>3915</u>	<u>18.40</u>
5500	3161	3065	8.79	3280	10.98	3482	13.24	3576	14.36	3666	15.47	3755	16.61	3843	17.78	<u>3929</u>	<u>18.96</u>		
6000	3448	3233	10.17	3426	12.40	3621	14.83	3714	16.06	3803	17.28	3888	18.49	3972	19.72				
6500	3736	3413	11.79	3583	14.02	3763	16.52	3854	17.85	3942	19.18								
7000	4023	3600	13.63	3754	15.91	3915	18.42	3999	19.78										
7500	4310	3790	15.69	3934	18.08														
8000	4598	3984	17.99																

182 H2

Outlet Area: 1.74 ft²
Wheel Dia.: 18.25"

Class FG Max. RPM: 4000
Class CF Max. RPM: 4000

Tip Speed (FPM) = 4.78 x RPM
Fan Efficiency Grade: FEG 71

CFM	OV	6" SP		8" SP		10" SP		11" SP		12" SP		13" SP		14" SP		15" SP		16" SP	
		RPM	BHP	RPM	BHP	RPM	BHP	RPM	BHP	RPM	BHP	RPM	BHP	RPM	BHP	RPM	BHP	RPM	BHP
2400	1379	2381	3.79																
2900	1667	2451	4.30	2758	5.95														
3400	1954	2564	5.04	2838	6.70	3100	8.53	3230	9.57	3361	10.70								
3900	2241	2703	5.93	2951	7.68	3190	9.57	3306	10.56	3421	11.60	3534	12.68	3647	13.84	3760	15.08	3874	16.41
4400	2529	2851	6.94	3088	8.86	3306	10.83	3413	11.86	3519	12.94	3623	14.02	3725	15.14	3826	16.29	3927	17.50
4900	2816	3004	8.03	3236	10.18	3443	12.30	3542	13.38	3639	14.48	3735	15.61	<u>3830</u>	<u>16.77</u>	<u>3924</u>	<u>17.96</u>		
5400	3103	3171	9.31	3385	11.57	3590	13.92	3686	15.10	3777	16.26	3867	17.44	3955	18.64				
5900	3391	3354	10.85	3543	13.12	3739	15.65	3833	16.93	3924	18.21								
6400	3678	3548	12.65	3716	14.94	3893	17.51	3983	18.87										
6900	3966	3748	14.69	3902	17.07														
7400	4253	3953	16.99																
7900	4540																		

Class FG (Fiberglass Wheel) Class CF (Carbon Fiber Wheel)

NOTES:
1. Performance certified is for installation Type B: Free inlet, Ducted outlet.
2. Power rating (BHP) does not include transmission losses.
3. Performance ratings do not include the effects of appurtenances (accessories).
4. Underlined values indicate maximum static efficiency.

200 M1

Outlet Area: 2.30 ft²
Wheel Dia.: 20.00"

Class FG Max. RPM: 3405
Class CF Max. RPM: 3955

Tip Speed (FPM) = 5.24 x RPM
Fan Efficiency Grade: FEG 75

CFM	OV	4" SP		6" SP		8" SP		10" SP		12" SP		14" SP		16" SP		18" SP		20" SP	
		RPM	BHP	RPM	BHP	RPM	BHP	RPM	BHP	RPM	BHP	RPM	BHP	RPM	BHP	RPM	BHP	RPM	BHP
3000	1304	1701	3.03																
3700	1609	1748	3.42	2082	5.56														
4400	1913	1835	4.06	2126	6.12	2406	8.64												
5100	2217	1943	4.85	2206	7.03	2454	9.44	2695	12.23	2936	15.59								
5800	2522	2058	5.73	2306	8.11	2533	10.64	2751	13.36	2963	16.39	3175	19.91	3384	23.86				
6500	2826	2179	6.73	2419	9.37	2630	12.03	2831	14.88	3026	17.90	3216	21.15	3403	24.75	3592	28.85	3778	33.29
7200	3130	2312	7.90	2534	10.71	2740	13.65	2927	16.61	3109	19.76	3285	23.04	3457	26.51	3627	30.27	3796	34.38
7900	3435	2457	9.33	2654	12.18	2854	15.38	3036	18.59	3205	21.84	3370	25.25	3532	28.83	3690	32.53	3845	36.42
8600	3739	2609	10.99	2785	13.90	2970	17.22	3150	20.74	3313	24.20	3468	27.72	3619	31.38	3769	35.23	3915	39.16
9300	4043	2766	12.90	2926	15.90	3093	19.27	3264	22.97	3426	26.74	3576	30.48	3719	34.26	3859	38.17		
10000	4348	2925	15.03	3075	18.21	3225	21.59	3383	25.38	3541	29.41	3689	33.44	3828	37.45				
10700	4652	3085	17.39	3228	20.79	3366	24.26	3509	28.06	3657	32.21	3803	36.52	3941	40.84				

200 M2

Outlet Area: 2.30 ft²
Wheel Dia.: 20.00"

Class FG Max. RPM: 3856
Class CF Max. RPM: 4000

Tip Speed (FPM) = 5.24 x RPM
Fan Efficiency Grade: FEG 71

CFM	OV	4" SP		6" SP		8" SP		10" SP		12" SP		14" SP		16" SP		18" SP		20" SP	
		RPM	BHP	RPM	BHP	RPM	BHP	RPM	BHP	RPM	BHP	RPM	BHP	RPM	BHP	RPM	BHP	RPM	BHP
3400	1478	1768	3.37																
4000	1739	1841	3.92	2148	5.99														
4600	2000	1933	4.58	2213	6.75	2477	9.19												
5200	2261	2037	5.36	2296	7.66	2539	10.17	2772	12.93	3003	16.18								
5800	2522	2142	6.19	2393	8.72	2618	11.34	2834	14.15	3043	17.20	3250	20.65						
6400	2783	2255	7.13	2497	9.89	2711	12.68	2912	15.60	3108	18.72	3297	22.00	3484	25.62	3671	29.69		
7000	3043	2379	8.25	2602	11.12	2812	14.17	3002	17.22	3185	20.44	3364	23.82	3538	27.37	3709	31.16	3879	35.30
7600	3304	2512	9.57	2713	12.49	2917	15.77	3102	19.05	3275	22.38	3443	25.86	3608	29.52	3768	33.27	3926	37.24
8200	3565	2651	11.08	2832	14.05	3022	17.43	3206	21.00	3373	24.52	3532	28.11	3687	31.84	3840	35.74	3990	39.75
8800	3826	2794	12.80	2960	15.84	3133	19.26	3310	23.02	3476	26.82	3630	30.60	3777	34.43	3922	38.42		
9400	4087	2938	14.68	3094	17.87	3252	21.33	3417	25.17	3580	29.22	3732	33.26	3875	37.28				
10000	4348	3084	16.77	3233	20.15	3378	23.65	3530	27.53	3686	31.74	3836	36.03	3977	40.31				

200 H1

Outlet Area: 2.08 ft²
Wheel Dia.: 20.00"

Class FG Max. RPM: 3706
Class CF Max. RPM: 4000

Tip Speed (FPM) = 5.24 x RPM
Fan Efficiency Grade: FEG 75

CFM	OV	6" SP		8" SP		10" SP		12" SP		14" SP		16" SP		18" SP		19" SP		20" SP	
		RPM	BHP	RPM	BHP	RPM	BHP	RPM	BHP	RPM	BHP	RPM	BHP	RPM	BHP	RPM	BHP	RPM	BHP
2200	1058																		
3000	1442	2129	4.46																
3800	1827	2216	5.27	2481	7.19	2742	9.52												
4600	2212	2359	6.48	2590	8.50	2812	10.66	3028	13.07	3244	15.86	3457	19.00						
5400	2596	2527	7.96	2739	10.17	2936	12.46	3129	14.92	3316	17.50	3499	20.28	3682	23.39	3773	25.07	3865	26.84
6200	2981	2701	9.60	2907	12.14	3092	14.66	3266	17.24	3435	19.95	3601	22.78	3763	25.71	3843	27.24	3923	28.83
7000	3365	2896	11.61	3079	14.28	3261	17.15	3427	19.99	3583	22.85	3733	25.78	3882	28.86	3956	30.45		
7800	3750	3113	14.14	3268	16.81	3433	19.83	3596	23.01	3748	26.18	3890	29.32						
8600	4135	3340	17.13	3478	19.92	3620	22.94	3768	26.24	3916	29.72								
9400	4519	3574	20.62	3700	23.58	3826	26.67	3955	29.98										
10200	4904	3811	24.58	3930	27.80														
11000	5288																		

200 H2

Outlet Area: 2.08 ft²
Wheel Dia.: 20.00"

Class FG Max. RPM: 4000
Class CF Max. RPM: 4000

Tip Speed (FPM) = 5.24 x RPM
Fan Efficiency Grade: FEG 71

CFM	OV	6" SP		8" SP		10" SP		12" SP		14" SP		16" SP		18" SP		19" SP		20" SP	
		RPM	BHP	RPM	BHP	RPM	BHP	RPM	BHP	RPM	BHP	RPM	BHP	RPM	BHP	RPM	BHP	RPM	BHP
2300	1106																		
3000	1442	2180	4.63																
3700	1779	2271	5.47	2538	7.41	2801	9.77												
4400	2115	2405	6.60	2641	8.65	2868	10.86	3089	13.32	3310	16.17								
5100	2452	2560	7.95	2778	10.19	2982	12.52	3181	15.01	3374	17.64	3563	20.50	3753	23.72	3848	25.47		
5800	2788	2721	9.45	2933	11.98	3124	14.51	3304	17.11	3480	19.85	3653	22.72	3821	25.70	3905	27.29	3988	28.92
6500	3125	2897	11.22	3092	13.93	3279	16.77	3450	19.58	3612	22.44	3770	25.42	3926	28.52				
7200	3462	3094	13.42	3262	16.15	3438	19.20	3607	22.34	3762	25.43	3910	28.56						
7900	3798	3302	16.03	3450	18.81	3605	21.90	3765	25.25	3919	28.68								
8600	4135	3517	19.04	3652	21.96	3788	25.06	3931	28.46										
9300	4471	3736	22.46	3863	25.60	3986	28.78												
10000	4808	3958	26.31																

Class FG (Fiberglass Wheel)

Class CF (Carbon Fiber Wheel)

NOTES:

1. Performance certified is for installation Type B: Free inlet, Ducted outlet.
2. Power rating (BHP) does not include transmission losses.
3. Performance ratings do not include the effects of appurtenances (accessories).
4. Underlined values indicate maximum static efficiency.

PERFORMANCE DATA

222 M1

Outlet Area: 2.85 ft²
Wheel Dia.: 22.25"

Class FG Max. RPM: 3028
Class CF Max. RPM: 3537

Tip Speed (FPM) = 5.83 x RPM
Fan Efficiency Grade: FE₈₀

CFM	OV	4" SP		6" SP		8" SP		10" SP		12" SP		14" SP		16" SP		18" SP		20" SP	
		RPM	BHP	RPM	BHP	RPM	BHP	RPM	BHP	RPM	BHP	RPM	BHP	RPM	BHP	RPM	BHP	RPM	BHP
2600	912																		
4000	1404	1480	3.59																
5400	1895	1582	4.72	1840	7.12	2076	9.75												
6800	2386	1732	6.21	1953	8.92	2162	11.85	2360	14.95	2547	18.24	2724	21.69						
8200	2877	1909	8.14	2103	11.15	2287	14.39	2463	17.81	2633	21.38	2797	25.10	2954	28.97	3105	32.98	3251	37.13
9600	3368	2102	10.52	2277	13.93	2441	17.46	2599	21.18	2752	25.08	2900	29.11	3044	33.24	3185	37.53	3322	41.94
11000	3860	2304	13.39	2465	17.25	2615	21.16	2758	25.18	2896	29.34	3031	33.67	3162	38.13	3291	42.74	3417	47.43
12400	4351	2517	16.92	2662	21.14	2801	25.49	2933	29.88	3059	34.33	3183	38.95	3304	43.72	3422	48.60	3537	53.57
13800	4842	2738	21.19	2867	25.69	2995	30.43	3119	35.29	3236	40.11	3350	45.02	3461	50.04				
15200	5333	2964	26.26	3080	31.05	3197	36.13	3312	41.37	3423	46.67	3529	51.95						
16600	5825	3195	32.24	3300	37.33	3405	42.65	3512	48.28										
18000	6316	3429	39.19	3525	44.60														

222 M2

Outlet Area: 2.85 ft²
Wheel Dia.: 22.25"

Class FG Max. RPM: 3429
Class CF Max. RPM: 4192

Tip Speed (FPM) = 5.83 x RPM
Fan Efficiency Grade: FE₇₅

CFM	OV	4" SP		7" SP		10" SP		13" SP		16" SP		19" SP		22" SP		25" SP		28" SP	
		RPM	BHP	RPM	BHP	RPM	BHP	RPM	BHP	RPM	BHP	RPM	BHP	RPM	BHP	RPM	BHP	RPM	BHP
3700	1298	1502	3.55																
5100	1789	1606	4.74	1996	8.47														
6500	2281	1764	6.31	2099	10.54	2407	15.21												
7900	2772	1953	8.36	2245	13.07	2517	18.26	2774	23.79	3017	29.67								
9300	3263	2158	10.91	2420	16.21	2663	21.87	2893	27.90	3114	34.25	3327	40.87	3531	47.80	3726	55.00		
10700	3754	2375	14.03	2614	20.02	2833	26.17	3042	32.68	3242	39.50	3436	46.62	3625	53.99	3809	61.62	3986	69.47
12100	4246	2602	17.87	2819	24.47	3021	31.26	3212	38.25	3396	45.56	3573	53.12	3746	60.97	3915	69.06		
13500	4737	2839	22.57	3032	29.64	3221	37.16	3398	44.74	3567	52.50	3731	60.53	3891	68.85				
14900	5228	3081	28.17	3254	35.70	3429	43.84	3594	52.08	3752	60.43	3904	68.91						
16300	5719	3327	34.77	3484	42.79	3643	51.40	3799	60.36	3947	69.34								
17700	6211	3577	42.50	3720	51.00	3864	60.02												
19100	6702	3829	51.40	3961	60.44														

222 H1

Outlet Area: 2.56 ft²
Wheel Dia.: 22.25"

Class FG Max. RPM: 3295
Class CF Max. RPM: 3967

Tip Speed (FPM) = 5.83 x RPM
Fan Efficiency Grade: FE₈₀

CFM	OV	6" SP		9" SP		12" SP		15" SP		18" SP		21" SP		23" SP		25" SP		27" SP	
		RPM	BHP	RPM	BHP	RPM	BHP	RPM	BHP	RPM	BHP	RPM	BHP	RPM	BHP	RPM	BHP	RPM	BHP
3500	1367	1827	4.85																
4600	1797	1909	6.06	2253	9.37														
5700	2227	2037	7.58	2341	11.24	2625	15.22	2886	19.46										
6800	2656	2198	9.47	2467	13.49	2721	17.82	2964	22.41	3193	27.25	3410	32.31	3549	35.80				
7900	3086	2379	11.79	2621	16.16	2851	20.87	3070	25.82	3282	31.00	3485	36.36	3617	40.10	3744	43.89	3868	47.77
9000	3516	2573	14.54	2795	19.37	3004	24.41	3204	29.72	3397	35.25	3585	41.01	3707	44.91	3827	48.91	3945	53.02
10100	3945	2776	17.76	2982	23.10	3174	28.53	3358	34.18	3536	40.06	3708	46.13	3821	50.31	3932	54.55		
11200	4375	2986	21.51	3177	27.34	3357	33.28	3527	39.28	3692	45.50	3852	51.92	3957	56.33				
12300	4805	3205	25.95	3380	32.18	3549	38.64	3708	45.09	3861	51.65								
13400	5234	3430	31.11	3589	37.68	3747	44.59	3898	51.60										
14500	5664	3660	37.08	3805	43.96	3950	51.22												
15600	6094	3893	43.87																

222 H2

Outlet Area: 2.56 ft²
Wheel Dia.: 22.25"

Class FG Max. RPM: 3785
Class CF Max. RPM: 4000

Tip Speed (FPM) = 5.83 x RPM
Fan Efficiency Grade: FE₇₅

CFM	OV	6" SP		9" SP		12" SP		15" SP		18" SP		21" SP		23" SP		25" SP		27" SP	
		RPM	BHP	RPM	BHP	RPM	BHP	RPM	BHP	RPM	BHP	RPM	BHP	RPM	BHP	RPM	BHP	RPM	BHP
3600	1406	1879	5.21																
4700	1836	1979	6.58	2320	10.04														
5800	2266	2128	8.31	2426	12.16	2706	16.31	2967	20.75										
6900	2695	2307	10.46	2571	14.68	2821	19.24	3060	24.06	3288	29.10	3505	34.40	3644	38.05				
8000	3125	2506	13.10	2744	17.74	2969	22.66	3185	27.87	3393	33.30	3595	38.94	3726	42.82	3853	46.77	3977	50.83
9100	3555	2716	16.22	2935	21.37	3140	26.68	3337	32.25	3527	38.06	3712	44.10	3833	48.24	3951	52.40		
10200	3984	2936	19.90	3139	25.61	3328	31.37	3509	37.31	3684	43.48	3855	49.90	3966	54.27				
11300	4414	3165	24.26	3351	30.43	3528	36.75	3696	43.13	3858	49.66								
12400	4844	3401	29.38	3570	35.93	3736	42.79	3894	49.70										
13500	5273	3644	35.38	3797	42.26	3951	49.57												
14600	5703	3891	42.28																
15700	6133																		

Class FG (Fiberglass Wheel)

Class CF (Carbon Fiber Wheel)

NOTES:

1. Performance certified is for installation Type B: Free inlet, Ducted outlet.
2. Power rating (BHP) does not include transmission losses.
3. Performance ratings do not include the effects of appurtenances (accessories).
4. Underlined values indicate maximum static efficiency.

245 M1

Outlet Area: 3.45 ft²
Wheel Dia.: 24.50"

Class FG Max. RPM: 2724
Class CF Max. RPM: 3199

Tip Speed (FPM) = 6.41 x RPM
Fan Efficiency Grade: FEG 80

CFM	OV	4" SP		7" SP		10" SP		12" SP		14" SP		16" SP		18" SP		20" SP		22" SP	
		RPM	BHP	RPM	BHP	RPM	BHP	RPM	BHP	RPM	BHP	RPM	BHP	RPM	BHP	RPM	BHP	RPM	BHP
4900	1420	1346	4.38																
6500	1884	1434	5.69	1779	10.14														
8100	2348	1560	7.36	1861	12.35	2137	17.86	2308	21.83	2469	25.95								
9700	2812	1710	9.51	1975	15.01	2222	21.08	2379	25.36	2529	29.80	2673	34.45	2811	39.24	2945	44.23		
11300	3275	1873	12.13	2112	18.24	2334	24.81	2475	29.44	2612	34.24	2746	39.20	2876	44.32	3002	49.62	3123	55.02
12900	3739	2044	15.27	2264	22.10	2466	29.20	2595	34.18	2720	39.33	2842	44.65	2961	50.09	3079	55.72	3193	61.41
14500	4203	2224	19.08	2426	26.61	2612	34.33	2730	39.62	2846	45.14	2958	50.77	3068	56.58	3176	62.54		
16100	4667	2411	23.65	2594	31.76	2768	40.21	2878	45.92	2984	51.71	3089	57.73	3191	63.86				
17700	5130	2603	29.07	2768	37.67	2932	46.89	3035	53.07	3134	59.26								
19300	5594	2799	35.42	2949	44.52	3100	54.31	3198	61.02										
20900	6058	2998	42.78	3135	52.38														
22500	6522	3199	51.21																

245 M2

Outlet Area: 3.45 ft²
Wheel Dia.: 24.50"

Class FG Max. RPM: 3084
Class CF Max. RPM: 3791

Tip Speed (FPM) = 6.41 x RPM
Fan Efficiency Grade: FEG 75

CFM	OV	4" SP		8" SP		12" SP		15" SP		18" SP		21" SP		24" SP		27" SP		30" SP	
		RPM	BHP	RPM	BHP	RPM	BHP	RPM	BHP	RPM	BHP	RPM	BHP	RPM	BHP	RPM	BHP	RPM	BHP
4500	1304	1365	4.32																
6400	1855	1475	5.96	1928	12.23														
8300	2406	1642	8.20	2028	15.36	2377	23.44												
10200	2957	1841	11.21	2175	19.26	2481	28.22	2699	35.42	2906	43.03	3101	50.95						
12100	3507	2054	14.96	2353	24.13	2625	33.96	2818	41.80	3005	50.02	3187	58.59	3361	67.42	3528	76.57	3690	86.04
14000	4058	2280	19.70	2550	30.06	2795	40.79	2970	49.31	3138	58.14	3302	67.35	3462	76.83	3618	86.55	3770	96.57
15900	4609	2518	25.67	2759	37.05	2984	48.93	3143	58.07	3297	67.56	3447	77.41	3592	87.48	3735	97.90		
17800	5159	2763	33.00	2977	45.25	3186	58.39	3333	68.35	3474	78.45	3611	88.84	3746	99.62				
19700	5710	3013	41.83	3204	54.92	3396	69.14	3534	80.06	3665	90.96								
21600	6261	3267	52.34	3439	66.28	3613	81.35	3742	93.16										
23500	6812	3524	64.69	3681	79.57														
25400	7362	3783	79.01																

245 H1

Outlet Area: 3.10 ft²
Wheel Dia.: 24.50"

Class FG Max. RPM: 2964
Class CF Max. RPM: 3587

Tip Speed (FPM) = 6.41 x RPM
Fan Efficiency Grade: FEG 80

CFM	OV	6" SP		9" SP		12" SP		15" SP		18" SP		21" SP		23" SP		25" SP		27" SP	
		RPM	BHP	RPM	BHP	RPM	BHP	RPM	BHP	RPM	BHP	RPM	BHP	RPM	BHP	RPM	BHP	RPM	BHP
4200	1355	1657	5.84																
5400	1742	1722	7.14	2038	11.09														
6600	2129	1820	8.74	2105	13.07	2367	17.78	2609	22.84										
7800	2516	1945	10.67	2199	15.40	2439	20.50	2665	25.90	2878	31.65	3079	37.65						
9000	2903	2087	13.00	2318	18.14	2535	23.64	2743	29.45	2943	35.54	3133	41.89	3255	46.28	3374	50.79	3489	55.37
10200	3290	2242	15.79	2452	21.33	2651	27.20	2842	33.43	3026	39.91	3205	46.65	3320	51.23	3433	55.96	3543	60.80
11400	3677	2403	18.98	2599	25.06	2782	31.31	2959	37.92	3129	44.79	3294	51.91	3402	56.78	3508	61.73		
12600	4065	2571	22.67	2755	29.33	2925	36.03	3089	42.99	3247	50.22	3401	57.73	3501	62.84				
13800	4452	2744	26.91	2916	34.09	3077	41.37	3230	48.76	3377	56.31	3521	64.18						
15000	4839	2924	31.85	3081	39.40	3234	47.27	3379	55.19	3517	63.15								
16200	5226	3108	37.50	3252	45.41	3396	53.78	3534	62.28										
17400	5613	3295	43.90	3428	52.18	3562	60.96												

245 H2

Outlet Area: 3.10 ft²
Wheel Dia.: 24.50"

Class FG Max. RPM: 3405
Class CF Max. RPM: 4041

Tip Speed (FPM) = 6.41 x RPM
Fan Efficiency Grade: FEG 75

CFM	OV	6" SP		9" SP		12" SP		15" SP		18" SP		21" SP		25" SP		29" SP		33" SP	
		RPM	BHP	RPM	BHP	RPM	BHP	RPM	BHP	RPM	BHP	RPM	BHP	RPM	BHP	RPM	BHP	RPM	BHP
4300	1387	1703	6.24																
5600	1806	1789	7.84	2101	12.00														
6900	2226	1917	9.83	2192	14.47	2449	19.46	2688	24.81										
8200	2645	2073	12.31	2317	17.39	2547	22.86	2767	28.63	2976	34.70	3175	41.09						
9500	3065	2248	15.37	2467	20.90	2675	26.82	2873	33.04	3066	39.60	3251	46.33	3488	55.78	3712	65.61		
10800	3484	2433	18.97	2634	25.09	2823	31.43	3005	38.12	3180	45.08	3351	52.34	3571	62.28	3784	72.67	3988	83.47
12100	3903	2625	23.16	2813	29.97	2987	36.83	3154	43.93	3316	51.34	3473	59.00	3676	69.57	3874	80.52		
13400	4323	2826	28.12	2999	35.50	3162	43.00	3317	50.61	3467	58.44	3613	66.54	3802	77.70	3985	89.19		
14700	4742	3034	33.96	3192	41.82	3345	49.96	3491	58.20	3630	66.48	3766	74.99	3942	86.67				
16000	5161	3248	40.78	3391	49.03	3534	57.75	3672	66.64	3803	75.51	3930	84.48						
17300	5581	3466	48.63	3596	57.26	3728	66.44	3858	75.93	3983	85.49								
18600	6000	3687	57.59	3807	66.67	3928	76.23												

Class FG (Fiberglass Wheel)

Class CF (Carbon Fiber Wheel)

NOTES:

- Performance certified is for installation Type B: Free inlet, Ducted outlet.
- Power rating (BHP) does not include transmission losses.
- Performance ratings do not include the effects of appurtenances (accessories).
- Underlined values indicate maximum static efficiency.

PERFORMANCE DATA

270 M1

Outlet Area: 4.19 ft²
Wheel Dia.: 27.00"

Class FG Max. RPM: 2448
Class CF Max. RPM: 2890

Tip Speed (FPM) = 7.07 x RPM
Fan Efficiency Grade: FEG 85

CFM	OV	4" SP		7" SP		10" SP		13" SP		15" SP		17" SP		19" SP		21" SP		23" SP	
		RPM	BHP	RPM	BHP	RPM	BHP	RPM	BHP	RPM	BHP	RPM	BHP	RPM	BHP	RPM	BHP	RPM	BHP
4200	1002	1193	4.21																
6300	1504	1233	5.52	1581	10.42														
8400	2005	1314	7.17	1631	12.83	1902	19.07	2147	25.92	2302	30.92								
10500	2506	1436	9.40	1707	15.63	1961	22.68	2189	30.20	2330	35.46	2464	40.89	2593	46.53	2720	52.53	2842	58.69
12600	3007	1584	12.32	1816	19.12	2039	26.71	2252	34.97	2388	40.82	2516	46.79	2637	52.84	2754	59.10	2866	65.44
14700	3508	1748	16.07	1950	23.47	2146	31.62	2336	40.39	2460	46.65	2581	53.10	2698	59.72	2812	66.59		
16800	4010	1922	20.75	2101	28.79	2275	37.52	2445	46.88	2556	53.40	2666	60.22	2773	67.22	2879	74.47		
18900	4511	2101	26.40	2263	35.18	2420	44.55	2572	54.42	2672	61.31	2772	68.49	2870	75.83				
21000	5012	2285	33.19	2434	42.80	2576	52.79	2714	63.24	2805	70.51								
23100	5513	2472	41.19	2610	51.66	2740	62.32	2867	73.45										
25200	6014	2661	50.50	2791	61.95														
27300	6516	2853	61.33																

270 M2

Outlet Area: 4.19 ft²
Wheel Dia.: 27.00"

Class FG Max. RPM: 2772
Class CF Max. RPM: 3425

Tip Speed (FPM) = 7.07 x RPM
Fan Efficiency Grade: FEG 75

CFM	OV	4" SP		8" SP		12" SP		16" SP		19" SP		22" SP		25" SP		28" SP		31" SP	
		RPM	BHP	RPM	BHP	RPM	BHP	RPM	BHP	RPM	BHP	RPM	BHP	RPM	BHP	RPM	BHP	RPM	BHP
2200	525	610	0.56																
4900	1169	725	1.16	1226	4.81														
7600	1814	942	2.37	1318	6.89	1650	12.50	2019	20.91										
10300	2458	1190	4.47	1481	9.88	1753	16.31	2089	26.12	2383	36.74	2650	48.16	2902	60.62				
13000	3103	1450	7.72	1691	14.20	1913	21.42	2197	32.22	2468	44.27	2719	57.10	2948	70.41	3163	84.34	3368	98.95
15700	3747	1717	12.44	1924	20.10	2112	28.20	2352	40.00	2587	53.00	2812	66.90	3031	81.80	3237	97.25		
18400	4391	1987	18.89	2169	27.80	2333	36.89	2542	49.84	2745	63.79	2944	78.67	3138	94.40	3327	110.95		
21100	5036	2261	27.44	2422	37.57	2569	47.81	2753	61.92	2932	76.91	3107	92.74	3280	109.43				
23800	5680	2536	38.33	2680	49.67	2814	61.15	2979	76.56	3139	92.69	3296	109.60						
26500	6325	2813	51.92	2943	64.48	3065	77.16	3216	94.06	3359	111.24								
29200	6969	3090	68.42	3208	82.19	3320	96.07												
31900	7613	3369	88.29																

270 H1

Outlet Area: 3.77 ft²
Wheel Dia.: 27.00"

Class FG Max. RPM: 2664
Class CF Max. RPM: 3241

Tip Speed (FPM) = 7.07 x RPM
Fan Efficiency Grade: FEG 80

CFM	OV	6" SP		9" SP		12" SP		15" SP		18" SP		21" SP		24" SP		26" SP		28" SP	
		RPM	BHP	RPM	BHP	RPM	BHP	RPM	BHP	RPM	BHP	RPM	BHP	RPM	BHP	RPM	BHP	RPM	BHP
4100	1088	1492	6.18																
5800	1538	1530	7.75	1832	12.27	2105	17.42												
7500	1989	1605	9.65	1887	14.84	2134	20.39	2360	26.33	2574	32.80								
9200	2440	1717	12.05	1963	17.70	2197	23.94	2411	30.51	2607	37.32	2792	44.46	2970	52.00	3086	57.32	3198	62.73
10900	2891	1859	15.14	2072	21.22	2279	27.88	2478	35.03	2668	42.57	2845	50.35	3012	58.36	3118	63.78	3222	69.37
12600	3342	2019	18.97	2206	25.52	2390	32.64	2568	40.18	2742	48.22	2911	56.62	3073	65.32	3177	71.29		
14300	3793	2191	23.64	2359	30.73	2522	38.27	2682	46.26	2840	54.71	2994	63.54	3145	72.75				
16000	4244	2373	29.31	2524	36.91	2671	44.93	2816	53.41	2958	62.24	3099	71.49	3237	81.05				
17700	4695	2560	35.97	2698	44.16	2832	52.70	2964	61.64	3093	70.90	3221	80.56						
19400	5146	2751	43.73	2879	52.59	3001	61.60	3122	71.04	3241	80.80								
21100	5597	2944	52.63	3065	62.26	3178	71.86												
22800	6048	3141	62.90																

270 H2

Outlet Area: 3.77 ft²
Wheel Dia.: 27.00"

Class FG Max. RPM: 3060
Class CF Max. RPM: 3650

Tip Speed (FPM) = 7.07 x RPM
Fan Efficiency Grade: FEG 75

CFM	OV	6" SP		9" SP		12" SP		15" SP		18" SP		22" SP		26" SP		30" SP		34" SP	
		RPM	BHP	RPM	BHP	RPM	BHP	RPM	BHP	RPM	BHP	RPM	BHP	RPM	BHP	RPM	BHP	RPM	BHP
4200	1114	1523	6.52																
6100	1618	1583	8.50	1884	13.33	2151	18.65												
8000	2122	1690	10.98	1960	16.51	2208	22.57	2430	28.89	2638	35.60	2901	45.29						
9900	2626	1845	14.29	2073	20.33	2293	26.98	2504	34.12	2701	41.61	2942	51.91	3167	62.67	3383	74.11	3592	86.30
11800	3130	2030	18.60	2226	25.21	2417	32.37	2603	40.02	2784	48.16	3016	59.58	3231	71.36	3433	83.53	3624	96.01
13700	3634	2234	24.07	2406	31.31	2573	39.02	2736	47.14	2898	55.79	3106	67.82	3310	80.59	3506	93.87		
15600	4138	2451	30.89	2602	38.70	2751	47.01	2896	55.69	3040	64.85	3228	77.55	3412	90.90	3592	104.87		
17500	4642	2674	39.08	2812	47.68	2945	56.57	3076	65.85	3205	75.51	3374	88.91	3541	102.92				
19400	5146	2903	48.88	3030	58.29	3150	67.78	3269	77.68	3386	87.90	3539	101.97						
21300	5650	3135	60.35	3254	70.68	3365	80.94	3473	91.41	3579	102.15								
23200	6154	3371	73.76	3482	84.96	3586	96.07												
25100	6658	3609	89.19																

Class FG (Fiberglass Wheel)

Class CF (Carbon Fiber Wheel)

NOTES:

1. Performance certified is for installation Type B: Free inlet, Ducted outlet.
2. Power rating (BHP) does not include transmission losses.
3. Performance ratings do not include the effects of appurtenances (accessories).
4. Underlined values indicate maximum static efficiency.

300 M1

Outlet Area: 5.17 ft²
Wheel Dia.: 30.00"

Class FG Max. RPM: 2180
Class CF Max. RPM: 2588

Tip Speed (FPM) = 7.85 x RPM
Fan Efficiency Grade: FEG 80

CFM	OV	4" SP		7" SP		10" SP		13" SP		15" SP		17" SP		19" SP		21" SP		23" SP	
		RPM	BHP	RPM	BHP	RPM	BHP	RPM	BHP	RPM	BHP	RPM	BHP	RPM	BHP	RPM	BHP	RPM	BHP
5200	1006	1074	5.21																
7800	1509	1110	6.82	1423	12.88														
10400	2012	1184	8.88	1469	15.89	1712	23.58	1933	32.08	2072	38.23								
13000	2515	1294	11.64	1537	19.33	1766	28.08	1971	37.37	2097	43.83	2218	50.57	2334	57.54	2448	64.94	2558	72.57
15600	3017	1428	15.28	1636	23.67	1837	33.09	2028	43.29	2150	50.50	2265	57.86	2374	65.37	2479	73.08	2580	80.94
18200	3520	1576	19.94	1758	29.11	1933	39.13	2105	50.08	2215	57.70	2324	65.71	2430	73.96	2532	82.41		
20800	4023	1733	25.75	1894	35.70	2050	46.48	2203	58.07	2303	66.17	2401	74.53	2497	83.17				
23400	4526	1895	32.79	2041	43.68	2181	55.20	2318	67.45	2408	75.99	2497	84.79	2585	93.86				
26000	5029	2061	41.22	2195	53.12	2322	65.44	2447	78.46	2528	87.39								
28600	5532	2230	51.18	2354	64.14	2471	77.37	2585	91.13										
31200	6035	2401	62.79	2517	76.90														
33800	6538	2574	76.24																

300 M2

Outlet Area: 5.17 ft²
Wheel Dia.: 30.00"

Class FG Max. RPM: 2469
Class CF Max. RPM: 3067

Tip Speed (FPM) = 7.85 x RPM
Fan Efficiency Grade: FEG 75

CFM	OV	4" SP		8" SP		12" SP		16" SP		19" SP		22" SP		25" SP		28" SP		31" SP	
		RPM	BHP	RPM	BHP	RPM	BHP	RPM	BHP	RPM	BHP	RPM	BHP	RPM	BHP	RPM	BHP	RPM	BHP
5300	1025	1096	5.48																
8300	1605	1153	7.59	1555	16.42														
11300	2186	1264	10.46	1616	20.72	1920	32.41	2188	45.16										
14300	2766	1419	14.50	1712	25.91	1988	39.06	2239	53.33	2410	64.49	2572	76.16	2727	88.35	2878	101.30		
17300	3346	1598	19.99	1846	32.60	2084	46.80	2312	62.42	2476	74.88	2631	87.82	2776	100.97	2914	114.43	3047	128.30
20300	3926	1791	27.18	2006	41.10	2212	56.39	2414	73.09	2560	86.31	2704	100.27	2844	114.74	2978	129.55		
23300	4507	1992	36.26	2182	51.59	2365	68.18	2542	85.87	2673	99.90	2802	114.53	2928	129.70	3053	145.55		
26300	5087	2197	47.39	2370	64.43	2533	82.25	2692	101.16	2809	116.01	2924	131.32	3039	147.32				
29300	5667	2406	60.90	2565	79.73	2712	98.87	2856	119.03	2962	134.76	3066	150.90						
32300	6248	2619	77.13	2766	97.82	2900	118.38	3030	139.66										
35300	6828	2833	96.18	2969	118.63														
38300	7408	3050	118.53																

300 H1

Outlet Area: 4.65 ft²
Wheel Dia.: 30.00"

Class FG Max. RPM: 2372
Class CF Max. RPM: 2902

Tip Speed (FPM) = 7.85 x RPM
Fan Efficiency Grade: FEG 80

CFM	OV	6" SP		9" SP		12" SP		15" SP		18" SP		21" SP		24" SP		26" SP		28" SP	
		RPM	BHP	RPM	BHP	RPM	BHP	RPM	BHP	RPM	BHP	RPM	BHP	RPM	BHP	RPM	BHP	RPM	BHP
5000	1075	1342	7.57																
7100	1527	1375	9.49	1648	15.06	1895	21.43												
9200	1978	1442	11.84	1696	18.20	1919	25.04	2123	32.37	2316	40.34								
11300	2430	1542	14.79	1764	21.73	1975	29.40	2168	37.50	2345	45.91	2512	54.71	2673	64.05	2777	70.56	2878	77.23
13400	2882	1669	18.57	1862	26.07	2049	34.29	2229	43.12	2400	52.40	2559	61.95	2709	71.79	2805	78.50	2899	85.41
15500	3333	1813	23.28	1982	31.35	2148	40.13	2309	49.44	2466	59.35	2618	69.67	2765	80.48	2858	87.78		
17600	3785	1968	29.04	2120	37.79	2267	47.09	2411	56.91	2554	67.36	2692	78.17	2828	89.51				
19700	4237	2131	35.97	2267	45.32	2401	55.29	2531	65.68	2659	76.56	2786	87.95						
21800	4688	2300	44.20	2424	54.27	2545	64.80	2664	75.82	2781	87.29	2896	99.16						
23900	5140	2471	53.70	2587	64.64	2697	75.76	2807	87.47										
26000	5591	2646	64.74	2754	76.52	2857	88.45												
28100	6043	2822	77.28																

300 H2

Outlet Area: 4.65 ft²
Wheel Dia.: 30.00"

Class FG Max. RPM: 2725
Class CF Max. RPM: 3269

Tip Speed (FPM) = 7.85 x RPM
Fan Efficiency Grade: FEG 75

CFM	OV	6" SP		9" SP		12" SP		15" SP		18" SP		22" SP		26" SP		30" SP		34" SP	
		RPM	BHP	RPM	BHP	RPM	BHP	RPM	BHP	RPM	BHP	RPM	BHP	RPM	BHP	RPM	BHP	RPM	BHP
5100	1097	1370	7.97																
7400	1591	1421	10.35	1692	16.23	1935	22.80												
9700	2086	1512	13.29	1758	20.07	1982	27.47	2183	35.20	2371	43.42								
12000	2581	1646	17.21	1855	24.62	2055	32.74	2247	41.51	2424	50.60	2642	63.20	2847	76.48	3043	90.56		
14300	3075	1807	22.28	1986	30.36	2161	39.13	2331	48.53	2496	58.48	2706	72.42	2901	86.88	3083	101.70	3256	116.99
16600	3570	1985	28.71	2143	37.57	2295	46.95	2445	56.94	2593	67.52	2783	82.28	2969	97.94	3146	114.13		
18900	4065	2175	36.71	2314	46.27	2450	56.39	2583	67.01	2715	78.22	2887	93.78	3055	110.15	3220	127.34		
21200	4559	2372	46.40	2497	56.77	2620	67.69	2740	79.03	2857	90.74	3012	107.15	3165	124.29				
23500	5054	2573	57.88	2689	69.29	2799	80.86	2908	92.93	3015	105.38	3155	122.56						
25800	5548	2777	71.32	2885	83.78	2987	96.28	3086	109.05	3184	122.23								
28100	6043	2985	87.05	3086	100.59	3181	114.05												
30400	6538	3195	105.16																

Class FG (Fiberglass Wheel)

Class CF (Carbon Fiber Wheel)

NOTES:

1. Performance certified is for installation Type B: Free inlet, Ducted outlet.
2. Power rating (BHP) does not include transmission losses.
3. Performance ratings do not include the effects of appurtenances (accessories).
4. Underlined values indicate maximum static efficiency.

PERFORMANCE DATA

330 M1

Outlet Area: 6.26 ft²
Wheel Dia.: 33.00"

Class FG Max. RPM: 1963
Class CF Max. RPM: 2342

Tip Speed (FPM) = 8.64 x RPM
Fan Efficiency Grade: FEG 85

CFM	OV	4" SP		7" SP		10" SP		13" SP		15" SP		17" SP		19" SP		21" SP		23" SP	
		RPM	BHP	RPM	BHP	RPM	BHP	RPM	BHP	RPM	BHP	RPM	BHP	RPM	BHP	RPM	BHP	RPM	BHP
6400	1022	970	6.28																
9600	1534	1002	8.18	1284	15.54														
12800	2045	1071	10.71	1325	19.01	1546	28.42	1745	38.75	1870	46.04								
16000	2556	1176	14.03	1390	23.36	1593	33.64	1779	44.82	1893	52.73	2002	60.99	2107	69.52	2210	78.42	2309	87.47
19200	3067	1302	18.43	1484	28.54	1660	39.89	1830	52.02	1940	60.51	2044	69.29	2143	78.44	2238	87.91	2329	97.54
22400	3578	1435	23.91	1600	35.12	1753	47.22	1903	60.39	2000	69.52	2097	78.99	2192	88.67	2284	98.62		
25600	4089	1574	30.64	1727	43.06	1864	56.08	1997	69.99	2085	79.84	2171	89.95	2256	100.36	2340	110.94		
28800	4601	1720	38.84	1859	52.43	1987	66.57	2107	81.36	2185	91.59	2263	102.25	2340	113.23				
32000	5112	1871	48.65	1996	63.47	2117	78.81	2228	94.57	2299	105.37								
35200	5623	2026	60.31	2137	76.20	2249	92.67												
38400	6134	2183	73.90	2284	91.03														
41600	6645	2342	89.64																

330 M2

Outlet Area: 6.26 ft²
Wheel Dia.: 33.00"

Class FG Max. RPM: 2223
Class CF Max. RPM: 2776

Tip Speed (FPM) = 8.64 x RPM
Fan Efficiency Grade: FEG 80

CFM	OV	4" SP		8" SP		12" SP		16" SP		19" SP		22" SP		25" SP		28" SP		31" SP	
		RPM	BHP	RPM	BHP	RPM	BHP	RPM	BHP	RPM	BHP	RPM	BHP	RPM	BHP	RPM	BHP	RPM	BHP
6600	1054	990	6.66																
10200	1629	1040	9.11	1403	19.79														
13800	2204	1143	12.50	1457	24.73	1731	38.71	1974	54.27										
17400	2780	1285	17.21	1543	30.86	1790	46.45	2017	63.29	2173	76.96	2320	91.24	2461	106.10	2597	121.44		
21000	3355	1442	23.40	1666	38.60	1877	55.67	2081	74.22	2229	88.76	2369	103.96	2501	119.88	2626	136.25	2747	153.25
24600	3930	1608	31.35	1812	48.42	1994	66.67	2173	86.72	2303	102.51	2432	118.91	2558	135.69	2680	153.11		
28200	4505	1784	41.39	1968	60.33	2133	80.22	2290	101.38	2407	118.33	2521	135.83	2634	154.02	2745	172.46		
31800	5080	1966	53.70	2129	74.51	2284	96.28	2426	118.89	2529	136.53	2632	154.99	2734	174.19				
35400	5655	2152	68.59	2297	91.34	2441	114.96	2574	139.32	2669	158.19	2761	177.46						
39000	6230	2342	86.47	2472	111.14	2602	136.46	2729	162.77										
42600	6805	2534	107.53	2651	133.96	2769	161.23												
46200	7380	2728	132.12																

330 H1

Outlet Area: 5.63 ft²
Wheel Dia.: 33.00"

Class FG Max. RPM: 2136
Class CF Max. RPM: 2627

Tip Speed (FPM) = 8.64 x RPM
Fan Efficiency Grade: FEG 80

CFM	OV	6" SP		9" SP		12" SP		15" SP		18" SP		21" SP		24" SP		26" SP		28" SP	
		RPM	BHP	RPM	BHP	RPM	BHP	RPM	BHP	RPM	BHP	RPM	BHP	RPM	BHP	RPM	BHP	RPM	BHP
6200	1101	1212	9.16																
8800	1563	1242	11.43	1488	18.27	1711	25.90												
11400	2025	1305	14.37	1532	21.92	1733	30.24	1917	39.25	2091	48.85								
14000	2487	1403	17.99	1597	26.40	1784	35.46	1958	45.13	2118	55.45	2269	66.34	2413	77.63	2507	85.47	2599	93.53
16600	2948	1524	22.59	1692	31.69	1855	41.62	2014	52.14	2167	63.05	2312	74.64	2447	86.64	2534	94.96	2618	103.40
19200	3410	1659	28.32	1808	38.16	1952	48.77	2092	60.04	2230	71.95	2365	84.16	2497	96.89	2581	105.59		
21800	3872	1799	35.19	1938	45.98	2066	57.23	2192	69.20	2316	81.83	2437	94.93	2556	108.38				
24400	4334	1945	43.39	2075	55.14	2194	67.29	2307	79.88	2418	93.02	2529	106.91						
27000	4796	2097	53.06	2215	65.69	2329	78.88	2434	92.30	2535	106.11								
29600	5258	2254	64.35	2361	77.98	2467	91.99	2568	106.46										
32200	5719	2414	77.34	2511	91.94	2609	106.90												
34800	6181	2577	92.29																

330 H2

Outlet Area: 5.63 ft²
Wheel Dia.: 33.00"

Class FG Max. RPM: 2454
Class CF Max. RPM: 2959

Tip Speed (FPM) = 8.64 x RPM
Fan Efficiency Grade: FEG 75

CFM	OV	6" SP		9" SP		12" SP		15" SP		18" SP		22" SP		26" SP		30" SP		34" SP	
		RPM	BHP	RPM	BHP	RPM	BHP	RPM	BHP	RPM	BHP	RPM	BHP	RPM	BHP	RPM	BHP	RPM	BHP
6400	1137	1238	9.74																
9200	1634	1284	12.50	1529	19.69	1747	27.67												
12000	2131	1370	16.11	1588	24.23	1790	33.03	1972	42.56	2141	52.61								
14800	2629	1497	20.79	1680	29.78	1856	39.51	2028	49.85	2189	60.78	2386	76.19	2570	92.41	2747	109.50		
17600	3126	1647	26.86	1804	36.61	1957	47.21	2106	58.51	2252	70.31	2441	86.71	2618	104.10	2782	122.14	2939	141.02
20400	3623	1806	34.35	1950	45.18	2083	56.48	2215	68.60	2344	81.32	2512	99.04	2678	117.47	2838	136.57		
23200	4121	1973	43.56	2106	55.45	2228	67.75	2344	80.52	2459	93.95	2610	112.78	2759	132.63	2904	152.85		
26000	4618	2146	54.53	2267	67.55	2383	81.04	2490	94.78	2593	108.94	2728	128.59	2863	149.44				
28800	5115	2327	67.71	2435	81.83	2542	96.30	2644	111.19	2739	126.21	2862	146.93						
31600	5613	2512	83.17	2608	98.30	2706	113.89	2802	129.80	2893	145.97								
34400	6110	2700	101.14	2788	117.48	2876	134.07												
37200	6607	2890	121.82																

Class FG (Fiberglass Wheel)

Class CF (Carbon Fiber Wheel)

NOTES:

- Performance certified is for installation Type B: Free inlet, Ducted outlet.
- Power rating (BHP) does not include transmission losses.
- Performance ratings do not include the effects of appurtenances (accessories).
- Underlined values indicate maximum static efficiency.

365 M1

Outlet Area: 7.66 ft²
Wheel Dia.: 36.50"

Class FG Max. RPM: 1737
Class CF Max. RPM: 2097

Tip Speed (FPM) = 9.56 x RPM
Fan Efficiency Grade: FEG 85

CFM	OV	4" SP		7" SP		10" SP		13" SP		15" SP		17" SP		19" SP		21" SP		23" SP	
		RPM	BHP	RPM	BHP	RPM	BHP	RPM	BHP	RPM	BHP	RPM	BHP	RPM	BHP	RPM	BHP	RPM	BHP
7900	1031	877	7.72																
11700	1527	905	9.96	1161	18.99														
15500	2023	965	12.96	1196	23.05	1396	34.51	1577	47.11	1691	56.06								
19300	2520	1056	16.85	1251	28.13	1437	40.67	1606	54.32	1709	63.90	1808	73.94	1904	84.37	1997	95.11	2088	106.28
23100	3016	1165	21.93	1333	34.27	1494	48.04	1650	62.77	1749	72.95	1844	83.73	1934	94.90	2020	106.36		
26900	3512	1282	28.32	1432	41.81	1573	56.51	1711	72.52	1800	83.57	1889	95.02	1976	106.81	2059	118.79		
30700	4008	1403	36.09	1543	51.05	1668	66.70	1791	83.63	1872	95.59	1951	107.83	2029	120.41				
34500	4504	1530	45.50	1658	61.83	1775	78.87	1885	96.70	1958	109.25	2029	122.04						
38300	5000	1662	56.77	1777	74.49	1888	92.96	1990	111.99	2055	124.98								
42100	5496	1797	70.05	1900	89.13	2004	109.03												
45900	5992	1934	85.52	2028	106.11														
49700	6488	2073	103.44																

365 M2

Outlet Area: 7.66 ft²
Wheel Dia.: 36.50"

Class FG Max. RPM: 1967
Class CF Max. RPM: 2485

Tip Speed (FPM) = 9.56 x RPM
Fan Efficiency Grade: FEG 80

CFM	OV	4" SP		8" SP		12" SP		16" SP		19" SP		22" SP		25" SP		28" SP		31" SP	
		RPM	BHP	RPM	BHP	RPM	BHP	RPM	BHP	RPM	BHP	RPM	BHP	RPM	BHP	RPM	BHP	RPM	BHP
8000	1044	895	8.11																
12400	1619	939	11.08	1268	24.12														
16800	2193	1031	15.19	1316	30.11	1564	47.18	1785	66.27										
21200	2768	1159	20.92	1394	37.66	1617	56.60	1823	77.25	1963	93.78	2096	111.19	2224	129.37	2348	148.27		
25600	3342	1301	28.47	1504	47.02	1695	67.84	1880	90.49	2014	108.24	2141	126.87	2260	146.25	2374	166.43	2483	187.08
30000	3916	1451	38.16	1635	58.92	1801	81.34	1963	105.81	2081	125.14	2198	145.17	2312	165.66	2422	186.86		
34400	4491	1609	50.31	1776	73.44	1926	97.81	2068	123.61	2174	144.32	2277	165.63	2379	187.76	2480	210.36		
38800	5065	1774	65.35	1921	90.66	2062	117.34	2190	144.84	2284	166.51	2378	189.24	2470	212.61				
43200	5640	1942	83.49	2073	111.20	2203	139.95	2324	169.82	2409	192.63								
47600	6214	2113	105.18	2231	135.33	2349	166.28	2464	198.43										
52000	6789	2287	130.92	2393	163.20														
56400	7363	2462	160.83																

365 H1

Outlet Area: 6.88 ft²
Wheel Dia.: 36.50"

Class FG Max. RPM: 1890
Class CF Max. RPM: 2352

Tip Speed (FPM) = 9.56 x RPM
Fan Efficiency Grade: FEG 80

CFM	OV	6" SP		9" SP		12" SP		15" SP		18" SP		21" SP		23" SP		25" SP		27" SP	
		RPM	BHP	RPM	BHP	RPM	BHP	RPM	BHP	RPM	BHP	RPM	BHP	RPM	BHP	RPM	BHP	RPM	BHP
7600	1105	1096	11.23																
10800	1570	1124	14.04	1346	22.41	1547	31.75												
14000	2035	1181	17.64	1386	26.90	1568	37.12	1734	48.17	1891	59.93								
17200	2500	1270	22.09	1445	32.40	1614	43.53	1772	55.46	1916	68.06	2052	81.36	2139	90.51	2225	100.03	2308	109.64
20400	2965	1382	27.86	1532	38.93	1679	51.11	1822	63.99	1961	77.48	2091	91.54	2174	101.42	2253	111.39	2330	121.64
23600	3430	1504	34.90	1639	47.03	1768	59.98	1895	73.90	2018	88.36	2140	103.37	2220	113.73	2297	124.22		
26800	3895	1632	43.44	1757	56.66	1872	70.43	1986	85.18	2097	100.58	2206	116.63	2278	127.68	2350	138.95		
30000	4360	1765	53.61	1882	68.04	1989	82.91	2091	98.39	2191	114.52	2290	131.40						
33200	4826	1903	65.56	2010	81.17	2112	97.27	2207	113.79	2298	130.76								
36400	5291	2046	79.56	2143	96.41	2238	113.56	2329	131.32										
39600	5756	2192	95.73	2280	113.79														
42800	6221	2341	114.38																

365 H2

Outlet Area: 6.88 ft²
Wheel Dia.: 36.50"

Class FG Max. RPM: 2171
Class CF Max. RPM: 2649

Tip Speed (FPM) = 9.56 x RPM
Fan Efficiency Grade: FEG 75

CFM	OV	6" SP		9" SP		12" SP		15" SP		18" SP		21" SP		25" SP		29" SP		33" SP	
		RPM	BHP	RPM	BHP	RPM	BHP	RPM	BHP	RPM	BHP	RPM	BHP	RPM	BHP	RPM	BHP	RPM	BHP
7800	1134	1119	11.88																
11200	1628	1160	15.23	1382	24.03	1580	33.81												
14600	2122	1237	19.62	1434	29.48	1617	40.23	1782	51.88	1935	64.14	2083	77.25						
18000	2616	1350	25.26	1516	36.21	1676	48.09	1832	60.70	1977	73.97	2112	87.97	2282	107.64	2444	128.27		
21400	3110	1484	32.57	1626	44.41	1765	57.33	1901	71.18	2034	85.59	2163	100.44	2326	121.34	2477	143.17	2621	166.04
24800	3605	1626	41.55	1757	54.77	1878	68.57	1997	83.23	2115	98.85	2230	115.00	2381	137.19	2528	160.32		
28200	4099	1775	52.59	1896	67.06	2007	82.08	2113	97.71	2217	114.01	2321	131.26	2456	155.02	2589	179.67		
31600	4593	1931	65.88	2041	81.71	2146	98.11	2243	114.82	2336	131.97	2429	149.97	2552	175.08				
35000	5087	2092	81.58	2191	98.84	2288	116.40	2381	134.60	2467	152.84	2551	171.67						
38400	5581	2258	100.16	2346	118.64	2435	137.57	2522	156.89	2605	176.67								
41800	6076	2427	121.80	2507	141.65	2587	161.79												
45200	6570	2597	146.55																

Class FG (Fiberglass Wheel)

Class CF (Carbon Fiber Wheel)

NOTES:

1. Performance certified is for installation Type B: Free inlet, Ducted outlet.
2. Power rating (BHP) does not include transmission losses.
3. Performance ratings do not include the effects of appurtenances (accessories).
4. Underlined values indicate maximum static efficiency.

PERFORMANCE DATA

402 M1

Outlet Area: 9.31 ft²
Wheel Dia.: 40.25"

Class FG Max. RPM: 1543
Class CF Max. RPM: 1884

Tip Speed (FPM) = 10.54 x RPM
Fan Efficiency Grade: FEG 85

CFM	OV	4" SP		7" SP		10" SP		12" SP		14" SP		16" SP		18" SP		20" SP		22" SP	
		RPM	BHP	RPM	BHP	RPM	BHP	RPM	BHP	RPM	BHP	RPM	BHP	RPM	BHP	RPM	BHP	RPM	BHP
9600	1031	795	9.38																
14200	1525	821	12.12	1053	23.08														
18800	2019	875	15.75	1084	27.96	1266	41.93	1376	51.91	1482	62.54								
23400	2513	956	20.39	1134	34.16	1302	49.28	1406	60.15	1503	71.65	1595	83.64	1683	96.00	1769	108.90	1853	122.31
28000	3008	1055	26.57	1207	41.49	1353	58.16	1448	69.96	1541	82.25	1629	94.95	1712	108.15	1792	121.94	1869	136.11
32600	3502	1160	34.24	1296	50.56	1425	68.52	1509	81.33	1591	94.62	1672	108.28	1752	122.36	1829	136.73		
37200	3996	1269	43.58	1396	61.69	1510	80.73	1585	94.30	1659	108.50	1731	123.05	1803	138.27	1874	153.75		
41800	4490	1384	54.97	1500	74.72	1607	95.50	1673	109.61	1739	124.43	1805	139.91	1870	155.88				
46400	4984	1502	68.39	1607	89.91	1708	112.32	1771	127.75	1831	143.36								
51000	5478	1624	84.39	1719	107.74	1813	131.75	1872	148.05										
55600	5972	1748	103.06	1834	128.10														
60200	6466	1874	124.72																

402 M2

Outlet Area: 9.31 ft²
Wheel Dia.: 40.25"

Class FG Max. RPM: 1747
Class CF Max. RPM: 2233

Tip Speed (FPM) = 10.54 x RPM
Fan Efficiency Grade: FEG 80

CFM	OV	4" SP		8" SP		12" SP		15" SP		18" SP		21" SP		24" SP		27" SP		30" SP	
		RPM	BHP	RPM	BHP	RPM	BHP	RPM	BHP	RPM	BHP	RPM	BHP	RPM	BHP	RPM	BHP	RPM	BHP
9800	1053	812	9.91																
15100	1622	852	13.50	1150	29.36														
20400	2191	934	18.41	1193	36.56	1418	57.31	1570	74.54										
25700	2760	1049	25.30	1262	45.55	1465	68.57	1608	87.26	1738	106.97	1861	127.87	1978	149.52	2092	172.23		
31000	3330	1177	34.41	1361	56.85	1535	82.14	1661	102.49	1785	123.83	1903	146.16	2013	169.37	2118	193.59	2218	218.37
36300	3899	1311	45.95	1479	71.19	1629	98.18	1740	120.22	1849	143.51	1955	167.35	2061	192.30	2162	217.65		
41600	4468	1453	60.50	1605	88.49	1741	117.91	1838	141.12	1935	165.81	2030	191.50	2124	218.26	2216	245.41		
46900	5038	1600	78.30	1735	109.05	1863	141.29	1951	166.14	2037	192.05	2123	219.26	2207	247.20				
52200	5607	1751	99.95	1871	133.52	1990	168.43	2073	195.36	2152	222.95	2228	251.03						
57500	6176	1905	125.87	2012	162.13	2121	199.90	2200	228.89										
62800	6745	2061	156.46	2158	195.52														
68100	7315	2218	192.00																

402 H1

Outlet Area: 8.36 ft²
Wheel Dia.: 40.25"

Class FG Max. RPM: 1679
Class CF Max. RPM: 2113

Tip Speed (FPM) = 10.54 x RPM
Fan Efficiency Grade: FEG 80

CFM	OV	6" SP		9" SP		12" SP		15" SP		18" SP		21" SP		23" SP		25" SP		27" SP	
		RPM	BHP	RPM	BHP	RPM	BHP	RPM	BHP	RPM	BHP	RPM	BHP	RPM	BHP	RPM	BHP	RPM	BHP
9200	1100	994	13.62																
13000	1555	1018	16.95	1220	27.09														
16800	2010	1067	21.17	1254	32.33	1420	44.75	1571	58.07	1714	72.27								
20600	2464	1145	26.42	1305	38.82	1460	52.26	1603	66.60	1735	81.96	1859	98.04	1939	109.19	2017	120.61	2093	132.29
24400	2919	1242	33.07	1381	46.52	1515	61.11	1647	76.69	1774	92.96	1892	109.96	1967	121.80	2039	133.84	2110	146.38
28200	3373	1350	41.31	1473	55.81	1592	71.44	1709	88.25	1822	105.63	1935	123.88	2007	136.15	2078	149.01		
32000	3828	1462	51.12	1577	67.04	1683	83.65	1787	101.26	1890	119.97	1990	139.25	2057	152.68				
35800	4282	1579	62.86	1686	80.08	1785	98.06	1878	116.52	1971	136.09	2063	156.61						
39600	4737	1701	76.72	1799	95.29	1893	114.67	1980	134.46	2064	154.90								
43400	5191	1826	92.70	1916	112.86	2004	133.49	2087	154.71										
47200	5646	1955	111.31	2036	132.78														
51000	6100	2086	132.62																

402 H2

Outlet Area: 8.36 ft²
Wheel Dia.: 40.25"

Class FG Max. RPM: 1928
Class CF Max. RPM: 2380

Tip Speed (FPM) = 10.54 x RPM
Fan Efficiency Grade: FEG 75

CFM	OV	6" SP		9" SP		12" SP		15" SP		18" SP		21" SP		25" SP		29" SP		33" SP	
		RPM	BHP	RPM	BHP	RPM	BHP	RPM	BHP	RPM	BHP	RPM	BHP	RPM	BHP	RPM	BHP	RPM	BHP
9400	1124	1014	14.35																
13600	1627	1052	18.52	1253	29.19	1432	41.01												
17800	2129	1122	23.88	1301	35.93	1467	49.03	1616	63.15	1755	78.12	1889	94.07						
22000	2632	1227	30.91	1377	44.26	1522	58.81	1662	74.04	1794	90.28	1916	107.29	2070	131.27	2216	156.29	2357	182.49
26200	3134	1351	40.01	1480	54.57	1605	70.30	1727	87.11	1847	104.72	1964	122.92	2111	148.26	2248	174.93	2378	202.74
30400	3636	1483	51.32	1600	67.35	1709	84.18	1817	102.21	1923	121.22	2026	140.83	2163	168.15	2295	196.18		
34600	4139	1620	65.06	1729	82.78	1829	101.13	1924	120.16	2018	140.14	2111	161.07	2233	190.19	2353	220.42		
38800	4641	1764	81.69	1863	101.13	1957	121.08	2045	141.64	2129	162.69	2212	184.55	2322	215.04				
43000	5144	1913	101.45	2001	122.48	2089	144.16	2172	166.26	2251	188.97	2326	211.87						
47200	5646	2066	124.77	2145	147.48	2225	170.75	2303	194.38	2378	218.65								
51400	6148	2222	152.02	2294	176.45	2366	201.29												
55600	6651	2379	183.24																

Class FG (Fiberglass Wheel)

Class CF (Carbon Fiber Wheel)

NOTES:

1. Performance certified is for installation Type B: Free inlet, Ducted outlet.
2. Power rating (BHP) does not include transmission losses.
3. Performance ratings do not include the effects of appurtenances (accessories).
4. Underlined values indicate maximum static efficiency.

445 M1

Outlet Area: 11.39 ft²
Wheel Dia.: 44.50"

Class FG Max. RPM: 1366
Class CF Max. RPM: 1687

Tip Speed (FPM) = 11.65 x RPM
Fan Efficiency Grade: FEG 85

CFM	OV	4" SP		7" SP		10" SP		12" SP		14" SP		16" SP		18" SP		20" SP		22" SP	
		RPM	BHP	RPM	BHP	RPM	BHP	RPM	BHP	RPM	BHP	RPM	BHP	RPM	BHP	RPM	BHP	RPM	BHP
11700	1027	719	11.44																
17200	1510	741	14.67	952	28.06														
22700	1993	788	18.99	979	33.88	1144	50.87	1244	63.01	1340	75.88								
28200	2476	859	24.47	1021	41.09	1175	59.52	1270	72.87	1357	86.66	1441	101.31	1521	116.32	1600	132.17	1676	148.38
33700	2959	945	31.64	1085	49.82	1219	70.09	1306	84.38	1390	99.15	1470	114.64	1546	130.86	1618	147.44		
39200	3442	1038	40.66	1163	60.51	1280	82.04	1357	97.57	1433	113.86	1507	130.31	1580	147.37	1650	164.84		
44700	3924	1134	51.57	1250	73.40	1355	96.55	1423	112.81	1491	130.05	1558	147.96	1623	166.09				
50200	4407	1235	64.80	1342	88.70	1439	113.64	1500	130.82	1561	148.86	1622	167.77	1681	186.92				
55700	4890	1339	80.42	1436	106.38	1528	133.33	1585	151.78	1640	170.64								
61200	5373	1447	99.07	1534	127.01	1620	155.85	1675	175.86										
66700	5856	1556	120.61	1635	150.64														
72200	6339	1667	145.62																

445 M2

Outlet Area: 11.39 ft²
Wheel Dia.: 44.50"

Class FG Max. RPM: 1547
Class CF Max. RPM: 1999

Tip Speed (FPM) = 11.65 x RPM
Fan Efficiency Grade: FEG 80

CFM	OV	4" SP		8" SP		11" SP		14" SP		17" SP		20" SP		23" SP		26" SP		29" SP	
		RPM	BHP	RPM	BHP	RPM	BHP	RPM	BHP	RPM	BHP	RPM	BHP	RPM	BHP	RPM	BHP	RPM	BHP
11900	1045	734	12.05																
18300	1607	769	16.35	1040	35.73														
24700	2169	842	22.29	1077	44.28	1234	63.11	1374	83.39	1507	105.33								
31100	2730	943	30.42	1138	55.14	1278	75.98	1411	98.17	1532	121.74	1645	146.61	1754	173.00	1858	200.10		
37500	3292	1057	41.25	1225	68.54	1345	91.39	1461	115.78	1575	141.34	1684	168.04	1786	196.00	1882	224.90	1975	255.17
43900	3854	1177	55.06	1329	85.49	1433	110.02	1535	136.30	1635	164.16	1732	192.78	1829	222.68	1922	253.20		
50300	4416	1303	72.27	1442	106.25	1536	132.89	1625	160.59	1714	190.14	1801	220.91	1887	253.01	1971	285.63		
56700	4978	1434	93.38	1558	130.75	1646	159.75	1728	189.74	1807	220.81	1885	253.13	1963	287.13				
63100	5540	1569	119.10	1679	159.80	1761	191.37	1838	223.66	1911	256.86	1981	290.70						
69500	6102	1706	149.70	1804	193.60	1879	227.78	1952	262.61										
75900	6664	1845	185.83	1934	233.16														
82300	7226	1985	227.82																

445 H1

Outlet Area: 10.24 ft²
Wheel Dia.: 44.50"

Class FG Max. RPM: 1487
Class CF Max. RPM: 1892

Tip Speed (FPM) = 11.65 x RPM
Fan Efficiency Grade: FEG 80

CFM	OV	6" SP		9" SP		12" SP		15" SP		18" SP		20" SP		22" SP		24" SP		26" SP	
		RPM	BHP	RPM	BHP	RPM	BHP	RPM	BHP	RPM	BHP	RPM	BHP	RPM	BHP	RPM	BHP	RPM	BHP
11300	1104	899	16.69																
15900	1553	921	20.73	1103	33.08	1269	46.96												
20500	2002	965	25.86	1134	39.47	1284	54.61	1421	70.93	1551	88.38								
25100	2451	1034	32.14	1180	47.38	1320	63.72	1449	81.16	1569	100.01	1644	112.90	1717	126.24	1789	140.12	1859	154.28
29700	2900	1121	40.20	1247	56.58	1369	74.44	1488	93.29	1603	113.12	1676	127.06	1745	141.26	1811	155.71	1876	170.79
34300	3350	1217	50.04	1329	67.75	1437	86.80	1543	107.24	1646	128.49	1715	143.31	1781	158.06	1846	173.43		
38900	3799	1318	61.94	1422	81.28	1518	101.46	1613	123.03	1706	145.70	1767	161.34	1828	177.53	1888	193.78		
43500	4248	1422	75.94	1520	97.05	1609	118.77	1694	141.36	1779	165.35	1834	181.66	1889	198.55				
48100	4697	1531	92.55	1621	115.30	1706	138.83	1785	162.92	1861	187.71								
52700	5146	1643	111.74	1725	136.25	1805	161.34	1880	187.06										
57300	5596	1759	134.17	1832	160.06														
61900	6045	1876	159.62																

445 H2

Outlet Area: 10.24 ft²
Wheel Dia.: 44.50"

Class FG Max. RPM: 1708
Class CF Max. RPM: 2131

Tip Speed (FPM) = 11.65 x RPM
Fan Efficiency Grade: FEG 75

CFM	OV	6" SP		9" SP		12" SP		15" SP		18" SP		21" SP		24" SP		28" SP		32" SP	
		RPM	BHP	RPM	BHP	RPM	BHP	RPM	BHP	RPM	BHP	RPM	BHP	RPM	BHP	RPM	BHP	RPM	BHP
11500	1123	918	17.60																
16500	1611	950	22.46	1133	35.55	1295	49.92												
21500	2100	1011	28.84	1174	43.43	1325	59.44	1460	76.59	1587	94.92	1708	114.17						
26500	2588	1102	37.06	1239	53.22	1372	70.89	1500	89.43	1620	109.26	1731	130.01	1836	151.57	1971	181.81	2100	213.18
31500	3076	1210	47.64	1328	65.24	1443	84.37	1555	104.78	1665	126.09	1772	148.23	1873	171.18	1999	203.13	2119	236.71
36500	3564	1326	60.83	1433	80.19	1533	100.56	1632	122.37	1729	145.34	1824	169.19	1918	193.70	2041	227.76		
41500	4053	1446	76.75	1546	98.14	1637	120.19	1725	143.37	1811	167.46	1897	192.99	1981	219.24	2091	255.26		
46500	4541	1572	95.98	1663	119.31	1749	143.36	1829	167.99	1907	193.65	1984	220.29	2060	247.84				
51500	5029	1702	118.65	1784	144.05	1865	170.17	1941	196.83	2012	223.75	2082	251.77						
56500	5518	1836	145.41	1910	172.90	1984	200.90	2055	229.12	2124	258.49								
61500	6006	1973	176.70	2039	205.83	2106	235.69												
66500	6494	2111	212.51																

Class FG (Fiberglass Wheel)

Class CF (Carbon Fiber Wheel)

NOTES:

1. Performance certified is for installation Type B: Free inlet, Ducted outlet.
2. Power rating (BHP) does not include transmission losses.
3. Performance ratings do not include the effects of appurtenances (accessories).
4. Underlined values indicate maximum static efficiency.

PERFORMANCE DATA

490 M1

Outlet Area: 13.80 ft²
Wheel Dia.: 49.00"

Class FG Max. RPM: 1215
Class CF Max. RPM: 1518

Tip Speed (FPM) = 12.83 x RPM
Fan Efficiency Grade: FEG 85

CFM	OV	4" SP		7" SP		9" SP		11" SP		13" SP		15" SP		17" SP		19" SP		21" SP	
		RPM	BHP	RPM	BHP	RPM	BHP	RPM	BHP	RPM	BHP	RPM	BHP	RPM	BHP	RPM	BHP	RPM	BHP
14100	1022	653	13.83																
20800	1507	673	17.78	864	33.91														
27500	1993	715	22.96	889	41.05	991	54.53	1085	68.93	1174	84.10	1260	100.27						
34200	2478	780	29.66	928	49.95	1022	64.58	1111	80.12	1193	96.52	1271	113.89	1345	131.78	1417	150.43	1487	169.74
40900	2964	859	38.47	986	60.52	1067	76.56	1147	93.67	1225	111.31	1300	129.78	1370	148.82	1437	168.68	1502	189.41
47600	3449	943	49.34	1057	73.52	1128	90.66	1199	109.17	1268	128.41	1335	147.98	1402	168.35	1467	189.29		
54300	3935	1031	62.70	1137	89.39	1200	107.67	1263	127.24	1325	147.69	1385	168.61	1445	190.56	1504	212.94		
61000	4420	1123	78.83	1200	107.83	1280	128.01	1336	148.49	1391	169.78	1447	192.46	1501	215.42				
67700	4906	1219	98.16	1306	129.48	1363	151.31	1416	173.50	1467	196.28	1516	219.35						
74400	5391	1317	120.83	1396	154.86	1448	177.96	1499	201.90										
81100	5877	1416	147.04	1488	183.68														
87800	6362	1517	177.52																

490 M2

Outlet Area: 13.80 ft²
Wheel Dia.: 49.00"

Class FG Max. RPM: 1376
Class CF Max. RPM: 1816

Tip Speed (FPM) = 12.83 x RPM
Fan Efficiency Grade: FEG 80

CFM	OV	4" SP		8" SP		11" SP		14" SP		17" SP		20" SP		23" SP		26" SP		29" SP	
		RPM	BHP	RPM	BHP	RPM	BHP	RPM	BHP	RPM	BHP	RPM	BHP	RPM	BHP	RPM	BHP	RPM	BHP
14400	1043	667	14.62																
22200	1609	699	19.88	944	43.27														
30000	2174	765	27.06	979	53.88	1121	76.63	1248	101.22	1368	127.65								
37800	2739	858	37.08	1034	66.97	1161	92.29	1282	119.29	1392	147.95	1495	178.31	1593	210.01	1687	242.74		
45600	3304	962	50.31	1114	83.42	1223	111.24	1328	140.83	1431	171.77	1530	204.22	1622	237.89	1710	273.38	1794	309.93
53400	3870	1071	67.11	1209	104.12	1303	133.85	1396	165.96	1486	199.57	1574	234.40	1662	270.77	1747	308.17		
61200	4435	1186	88.14	1312	129.45	1397	161.74	1478	195.53	1559	231.59	1638	269.08	1715	307.60	1792	347.78		
69000	5000	1307	114.35	1418	159.44	1499	195.17	1573	231.53	1644	269.05	1715	308.53	1785	349.47				
76800	5565	1430	145.82	1529	195.19	1603	233.47	1673	272.82	1739	313.11	1803	354.59						
84600	6130	1555	183.35	1644	236.95	1711	278.16	1777	320.45										
92400	6696	1682	227.74	1762	285.11														
100200	7261	1810	279.38																

490 H1

Outlet Area: 12.39 ft²
Wheel Dia.: 49.00"

Class FG Max. RPM: 1323
Class CF Max. RPM: 1702

Tip Speed (FPM) = 12.83 x RPM
Fan Efficiency Grade: FEG 80

CFM	OV	6" SP		9" SP		12" SP		15" SP		18" SP		20" SP		22" SP		24" SP		26" SP	
		RPM	BHP	RPM	BHP	RPM	BHP	RPM	BHP	RPM	BHP	RPM	BHP	RPM	BHP	RPM	BHP	RPM	BHP
13700	1106	816	20.20																
19200	1550	836	25.07	1002	40.07														
24700	1994	875	31.17	1029	47.63	1165	65.88	1290	85.66	1408	106.68								
30200	2437	936	38.61	1069	56.95	1197	76.70	1315	97.94	1423	120.43	1492	136.19	1559	152.45	1624	169.03	1688	186.23
35700	2881	1013	48.08	1128	67.80	1240	89.43	1350	112.45	1454	136.22	1520	152.97	1583	170.20	1643	187.64	1702	205.78
41200	3325	1099	59.77	1201	81.04	1300	104.04	1397	128.71	1492	154.53	1554	172.06	1615	190.13	1674	208.64		
46700	3769	1189	73.76	1284	97.05	1372	121.40	1459	147.41	1545	175.06	1600	193.64	1656	213.20				
52200	4213	1282	90.29	1371	115.53	1453	141.85	1531	169.13	1608	197.73	1659	217.64						
57700	4657	1379	109.76	1462	137.24	1539	165.34	1611	194.24	1681	224.22								
63200	5101	1479	132.32	1554	161.65	1628	192.06	1696	222.80										
68700	5545	1582	158.45	1650	189.81														
74200	5989	1687	188.43																

490 H2

Outlet Area: 12.39 ft²
Wheel Dia.: 49.00"

Class FG Max. RPM: 1519
Class CF Max. RPM: 1917

Tip Speed (FPM) = 12.83 x RPM
Fan Efficiency Grade: FEG 75

CFM	OV	6" SP		9" SP		12" SP		15" SP		18" SP		21" SP		24" SP		27" SP		31" SP	
		RPM	BHP	RPM	BHP	RPM	BHP	RPM	BHP	RPM	BHP	RPM	BHP	RPM	BHP	RPM	BHP	RPM	BHP
14000	1130	833	21.33																
20000	1614	863	27.26	1028	42.97	1176	60.51												
26000	2098	918	34.95	1066	52.59	1202	71.76	1326	92.79	1441	114.89								
32000	2583	999	44.71	1124	64.31	1245	85.65	1362	108.21	1470	131.97	1571	157.10	1667	183.35	1759	210.44	1878	248.19
38000	3067	1096	57.37	1203	78.54	1308	101.70	1410	126.35	1510	151.99	1608	178.96	1700	206.83	1786	235.45	1897	275.89
44000	3551	1199	72.88	1297	96.35	1389	121.16	1479	147.44	1568	175.39	1654	203.98	1740	233.67	1824	264.19		
50000	4036	1307	91.88	1398	117.62	1482	144.52	1562	172.44	1641	201.73	1719	232.40	1796	264.27	1871	296.61		
56000	4520	1420	114.71	1503	142.78	1582	171.97	1655	201.72	1726	232.62	1796	264.64	1866	298.20				
62000	5004	1537	141.71	1612	172.31	1686	203.81	1755	235.86	1820	268.44	1884	302.29						
68000	5488	1658	173.67	1725	206.56	1792	240.02	1858	274.54										
74000	5973	1780	210.42	1841	245.73	1902	281.55												
80000	6457	1904	252.86																

Class FG (Fiberglass Wheel)

Class CF (Carbon Fiber Wheel)

NOTES:

1. Performance certified is for installation Type B: Free inlet, Ducted outlet.
2. Power rating (BHP) does not include transmission losses.
3. Performance ratings do not include the effects of appurtenances (accessories).
4. Underlined values indicate maximum static efficiency.

542 M1

Outlet Area: 16.92 ft²
Wheel Dia.: 54.25"

Class FG Max. RPM: 1074
Class CF Max. RPM: 1350

Tip Speed (FPM) = 14.20 x RPM
Fan Efficiency Grade: FEG 85

CFM	OV	4" SP		7" SP		9" SP		11" SP		13" SP		15" SP		17" SP		19" SP		21" SP	
		RPM	BHP	RPM	BHP	RPM	BHP	RPM	BHP	RPM	BHP	RPM	BHP	RPM	BHP	RPM	BHP	RPM	BHP
17300	1022	590	16.97																
25300	1495	607	21.64	780	41.35														
33300	1968	644	27.88	802	49.93	894	66.30	979	83.79	1060	102.35								
41300	2441	700	35.72	835	60.37	921	78.21	1002	97.27	1076	117.19	1147	138.45	1214	160.16	1280	183.12	1343	206.40
49300	2914	768	45.88	884	72.58	959	92.30	1032	112.98	1103	134.36	1171	156.84	1235	180.31	1296	204.63		
57300	3387	842	58.64	946	87.90	1011	108.68	1076	131.14	1139	154.41	1201	178.33	1263	203.44	1322	228.90		
65300	3859	919	74.19	1015	106.18	1074	128.76	1131	152.19	1188	177.07	1244	202.95	1299	229.61				
73300	4332	999	92.77	1088	127.74	1143	152.21	1195	177.30	1245	202.88	1296	230.18	1346	258.29				
81300	4805	1083	115.12	1164	153.14	1216	179.49	1264	206.11	1310	233.28								
89300	5278	1169	141.31	1242	182.29	1290	210.22	1337	239.36										
97300	5751	1256	171.58	1322	215.41														
105300	6223	1345	206.83																

542 M2

Outlet Area: 16.92 ft²
Wheel Dia.: 54.25"

Class FG Max. RPM: 1217
Class CF Max. RPM: 1600

Tip Speed (FPM) = 14.20 x RPM
Fan Efficiency Grade: FEG 80

CFM	OV	4" SP		7" SP		10" SP		13" SP		16" SP		19" SP		22" SP		25" SP		28" SP	
		RPM	BHP	RPM	BHP	RPM	BHP	RPM	BHP	RPM	BHP	RPM	BHP	RPM	BHP	RPM	BHP	RPM	BHP
17700	1046	602	17.91																
27000	1596	630	24.14	802	45.19														
36300	2145	687	32.62	835	56.63	970	83.53	1089	112.92	1200	144.50								
45600	2695	768	44.36	890	71.13	1007	101.03	1119	132.90	1222	167.23	1318	203.87	1408	241.75	1495	281.39		
54900	3245	859	59.80	964	89.32	1065	122.18	1162	157.38	1257	194.36	1349	233.36	1434	273.70	1515	316.24	1593	360.71
64200	3794	954	79.25	1051	112.64	1138	147.75	1224	185.92	1307	225.97	1389	268.18	1469	311.13	1548	356.46		
73500	4344	1055	103.74	1142	140.54	1223	179.46	1298	219.69	1372	262.27	1445	307.13	1517	353.96	1588	402.23		
82800	4894	1160	133.71	1237	174.20	1313	216.79	1382	260.22	1448	305.19	1513	352.01	1578	401.32				
92100	5443	1267	169.62	1336	214.10	1405	259.89	1471	307.25	1532	355.25	1591	404.72						
101400	5993	1377	212.86	1439	261.10	1501	310.37	1563	361.34										
110700	6543	1488	263.53	1544	315.24	1600	368.21												
120000	7092	1600	322.42																

542 H1

Outlet Area: 15.22 ft²
Wheel Dia.: 54.25"

Class FG Max. RPM: 1169
Class CF Max. RPM: 1515

Tip Speed (FPM) = 14.20 x RPM
Fan Efficiency Grade: FEG 80

CFM	OV	6" SP		9" SP		12" SP		15" SP		17" SP		19" SP		21" SP		23" SP		25" SP	
		RPM	BHP	RPM	BHP	RPM	BHP	RPM	BHP	RPM	BHP	RPM	BHP	RPM	BHP	RPM	BHP	RPM	BHP
16800	1104	737	24.77																
23400	1537	754	30.53	905	48.99														
30000	1971	788	37.80	928	57.93	1052	80.43	1165	104.52	1237	121.49	1306	138.99						
36600	2405	842	46.77	963	69.09	1079	93.07	1186	119.06	1252	137.21	1316	156.26	1377	175.56	1437	195.64	1496	216.46
43200	2838	909	57.91	1014	81.93	1116	108.22	1216	136.11	1280	155.39	1341	175.39	1399	196.00	1455	217.30	1509	239.03
49800	3272	984	71.57	1078	97.65	1168	125.53	1257	155.70	1315	176.52	1372	197.60	1428	219.24	1483	241.80		
56400	3706	1064	88.19	1150	116.30	1231	146.09	1310	177.53	1363	199.97	1414	222.48	1465	245.81				
63000	4139	1146	107.66	1227	138.21	1301	169.84	1373	203.25	1420	226.21	1467	250.14	1514	275.01				
69600	4573	1231	130.39	1306	163.27	1377	197.65	1443	232.82	1486	257.05								
76200	5007	1319	156.80	1388	192.30	1455	228.85												
82800	5440	1410	187.43	1472	225.09														
89400	5874	1502	222.10																

542 H2

Outlet Area: 15.22 ft²
Wheel Dia.: 54.25"

Class FG Max. RPM: 1343
Class CF Max. RPM: 1706

Tip Speed (FPM) = 14.20 x RPM
Fan Efficiency Grade: FEG 75

CFM	OV	6" SP		9" SP		12" SP		15" SP		18" SP		21" SP		24" SP		27" SP		30" SP	
		RPM	BHP	RPM	BHP	RPM	BHP	RPM	BHP	RPM	BHP	RPM	BHP	RPM	BHP	RPM	BHP	RPM	BHP
17100	1124	753	26.16																
24300	1597	778	33.11	928	52.41	1062	73.80												
31500	2070	826	42.31	961	63.83	1084	87.21	1196	112.76	1301	139.90								
38700	2543	896	53.75	1011	77.78	1121	103.61	1227	130.96	1325	160.02	1417	190.84	1504	222.78	1588	255.98	1670	290.61
45900	3016	981	68.63	1079	94.39	1175	122.57	1269	152.82	1360	183.84	1449	216.66	1532	250.53	1611	285.98	1686	322.21
53100	3489	1072	86.93	1161	115.28	1245	145.33	1328	177.54	1409	211.35	1489	246.68	1567	282.45	1644	319.95		
60300	3962	1167	109.19	1251	140.68	1327	173.07	1400	206.88	1472	242.31	1544	279.91	1614	318.39	1684	358.42		
67500	4435	1267	136.11	1343	170.04	1415	205.41	1481	241.15	1546	278.65	1611	318.01	1675	358.76				
74700	4908	1370	167.70	1438	204.27	1506	242.48	1569	281.34	1629	321.17	1687	361.88						
81900	5381	1476	204.74	1537	244.11	1600	285.27	1660	326.88										
89100	5854	1584	247.75	1640	290.32	1696	333.46												
96300	6327	1693	296.94																

Class FG (Fiberglass Wheel)

Class CF (Carbon Fiber Wheel)

NOTES:

1. Performance certified is for installation Type B: Free inlet, Ducted outlet.
2. Power rating (BHP) does not include transmission losses.
3. Performance ratings do not include the effects of appurtenances (accessories).
4. Underlined values indicate maximum static efficiency.

PERFORMANCE DATA

600 M1

Outlet Area: 20.70 ft²
Wheel Dia.: 60.00"

Class FG Max. RPM: 951
Class CF Max. RPM: 1215

Tip Speed (FPM) = 15.71 x RPM
Fan Efficiency Grade: FEG 85

CFM	OV	4" SP		7" SP		9" SP		11" SP		13" SP		15" SP		17" SP		19" SP		21" SP	
		RPM	BHP	RPM	BHP	RPM	BHP	RPM	BHP	RPM	BHP	RPM	BHP	RPM	BHP	RPM	BHP	RPM	BHP
21200	1024	533	20.73																
30900	1493	549	26.48	706	50.70														
40600	1961	581	33.87	724	60.72	808	80.91	885	102.29	959	125.21								
50300	2430	631	43.32	754	73.50	832	95.26	905	118.42	972	142.74	1036	168.54	1098	195.72	1157	223.32	1215	252.34
60000	2899	693	55.84	798	88.36	866	112.41	932	137.51	997	163.90	1058	191.09	1116	219.79	1171	249.34		
69700	3367	759	71.16	853	106.72	912	132.04	971	159.43	1028	187.69	1085	217.23	1141	247.73	1194	278.51		
79400	3836	827	89.58	915	128.88	968	156.14	1020	184.79	1072	215.28	1122	246.28	1172	278.78				
89100	4304	899	112.05	980	154.68	1030	184.54	1077	214.99	1123	246.52	1169	279.59	1214	313.55				
98800	4773	974	138.82	1048	185.21	1095	217.19	1139	249.87	1181	283.15								
108500	5242	1051	170.24	1117	219.78	1161	253.96	1203	288.95										
118200	5710	1129	206.57	1189	259.79														
127900	6179	1208	248.37																

600 M2

Outlet Area: 20.70 ft²
Wheel Dia.: 60.00"

Class FG Max. RPM: 1077
Class CF Max. RPM: 1440

Tip Speed (FPM) = 15.71 x RPM
Fan Efficiency Grade: FEG 80

CFM	OV	4" SP		7" SP		10" SP		13" SP		16" SP		19" SP		22" SP		25" SP		28" SP	
		RPM	BHP	RPM	BHP	RPM	BHP	RPM	BHP	RPM	BHP	RPM	BHP	RPM	BHP	RPM	BHP	RPM	BHP
21600	1043	544	21.84																
32900	1589	569	29.40	725	55.16														
44200	2135	620	39.68	754	68.90	876	101.65	984	137.60	1085	176.35								
55500	2681	692	53.75	803	86.45	910	123.21	1011	161.90	1104	203.71	1191	248.47	1273	295.03	1352	343.55		
66800	3227	774	72.47	870	108.73	961	148.54	1049	191.44	1136	236.98	1219	284.39	1296	333.73	1369	385.42	1439	439.09
78100	3773	859	95.86	947	136.51	1026	179.30	1104	225.77	1180	275.04	1254	326.14	1327	378.82	1398	433.60		
89400	4319	950	125.53	1029	170.34	1102	217.49	1170	266.44	1238	318.93	1304	373.41	1369	430.16	1434	489.47		
100700	4865	1044	161.54	1114	210.82	1183	262.71	1245	315.16	1305	369.98	1365	427.91	1424	488.03				
112000	5411	1140	204.76	1203	259.05	1266	315.02	1325	372.03	1381	431.08	1435	491.84						
123300	5957	1239	256.95	1295	315.40	1351	375.01	1407	436.72										
134600	6502	1338	317.46	1389	380.40	1440	444.86												
145900	7048	1439	388.59																

600 H1

Outlet Area: 18.60 ft²
Wheel Dia.: 60.00"

Class FG Max. RPM: 1035
Class CF Max. RPM: 1363

Tip Speed (FPM) = 15.71 x RPM
Fan Efficiency Grade: FEG 80

CFM	OV	6" SP		9" SP		12" SP		15" SP		17" SP		19" SP		21" SP		23" SP		25" SP	
		RPM	BHP	RPM	BHP	RPM	BHP	RPM	BHP	RPM	BHP	RPM	BHP	RPM	BHP	RPM	BHP	RPM	BHP
20500	1102	667	30.34																
28600	1538	682	37.38	818	59.84														
36700	1973	713	46.34	839	70.85	951	98.33	1053	127.73	1118	148.43	1181	170.09						
44800	2409	761	57.14	871	84.61	976	114.01	1072	145.54	1132	167.88	1190	191.24	1245	214.79	1299	239.23	1352	264.49
52900	2844	822	70.86	917	100.28	1010	132.78	1100	166.79	1158	190.48	1213	214.89	1265	239.88	1316	266.17		
61000	3280	891	87.90	975	119.54	1057	153.95	1137	190.72	1189	216.01	1241	242.10	1292	268.84	1341	296.00		
69100	3715	963	108.17	1041	142.72	1114	179.14	1186	218.01	1233	245.00	1279	272.52	1325	301.05				
77200	4151	1037	131.95	1111	169.72	1178	208.58	1242	248.92	1285	277.38	1327	306.39						
85300	4586	1114	159.84	1183	200.73	1246	242.24	1306	285.55	1344	314.64								
93400	5022	1195	192.86	1257	236.25	1317	280.74												
101500	5457	1277	230.29	1333	276.48														
109600	5892	1361	273.39																

600 H2

Outlet Area: 15.22 ft²
Wheel Dia.: 60.00"

Class FG Max. RPM: 1189
Class CF Max. RPM: 1535

Tip Speed (FPM) = 15.71 x RPM
Fan Efficiency Grade: FEG 75

CFM	OV	6" SP		9" SP		12" SP		15" SP		18" SP		21" SP		24" SP		27" SP		30" SP	
		RPM	BHP	RPM	BHP	RPM	BHP	RPM	BHP	RPM	BHP	RPM	BHP	RPM	BHP	RPM	BHP	RPM	BHP
20900	1124	681	32.01																
29700	1597	704	40.59	839	64.07	961	90.45												
38500	2070	746	51.58	869	78.08	980	106.61	1081	137.74	1176	170.93								
47300	2543	810	65.72	913	94.79	1013	126.49	1109	159.96	1198	195.67	1281	233.25	1360	272.50	1436	313.13	1510	355.36
56100	3016	887	83.97	976	115.61	1063	150.18	1147	186.72	1230	224.99	1310	264.85	1385	306.25	1456	349.27	1524	393.69
64900	3489	969	106.26	1050	141.14	1126	177.93	1200	216.77	1274	258.52	1346	301.48	1417	345.53	1486	390.89		
73700	3962	1055	133.52	1130	171.61	1199	211.30	1265	252.58	1331	296.45	1396	342.36	1459	389.15	1522	437.80		
82500	4435	1144	165.84	1214	207.88	1278	250.48	1339	294.98	1398	340.99	1456	388.52	1514	438.42				
91300	4909	1238	204.82	1300	249.80	1361	296.22	1418	343.73	1472	392.20	1525	442.42						
100100	5382	1333	249.62	1389	298.21	1445	347.80	1500	399.18										
108900	5855	1431	302.34	1482	354.60	1533	407.59												
117700	6328	1530	362.75																

Class FG (Fiberglass Wheel)

Class CF (Carbon Fiber Wheel)

NOTES:

1. Performance certified is for installation Type B: Free inlet, Ducted outlet.
2. Power rating (BHP) does not include transmission losses.
3. Performance ratings do not include the effects of appurtenances (accessories).
4. Underlined values indicate maximum static efficiency.

Arrg. 1 M1/M2, Sizes 165 – 365 Rotatable

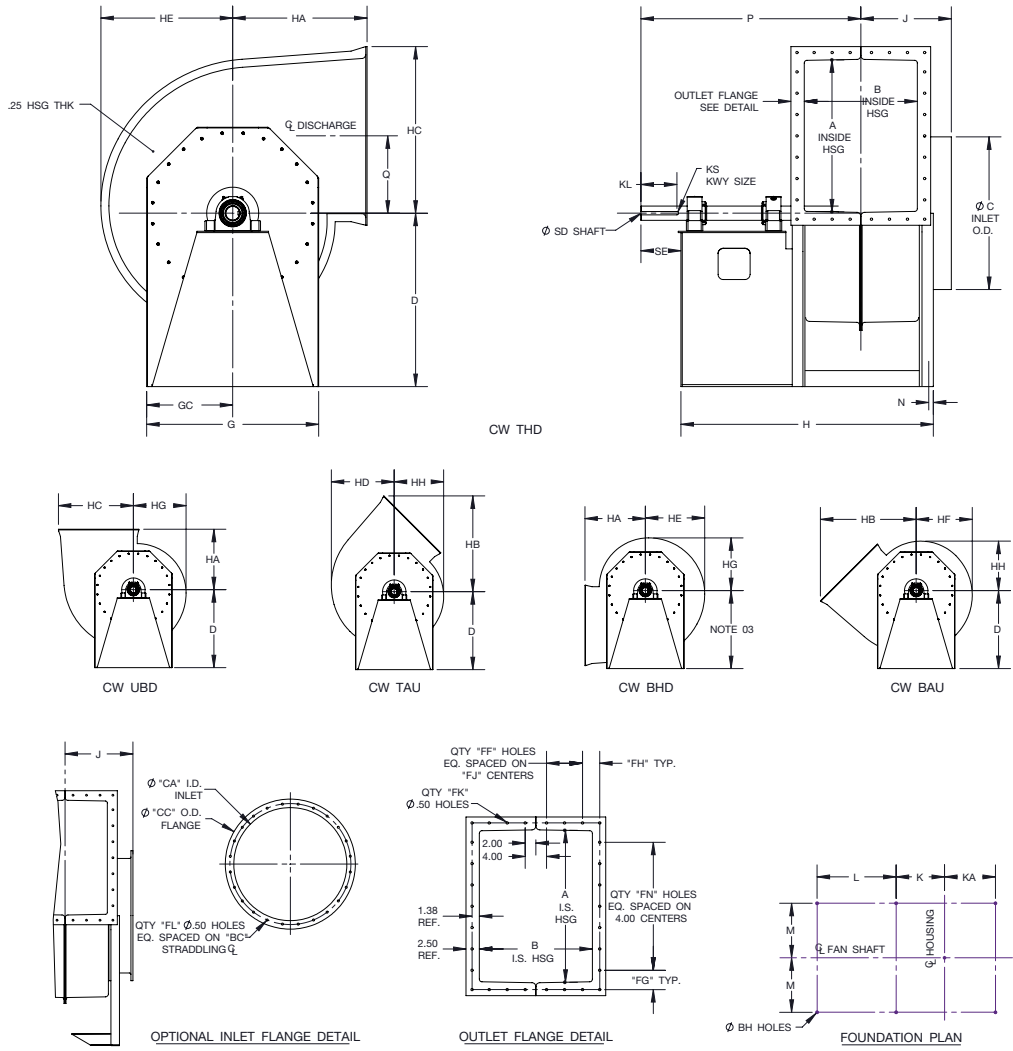

Notes:

1. Outlet flanges are included on all discharges. Drilling is optional.
2. CW rotation is shown, CCW rotation is similar but opposite.
3. All units are rotatable to all positions shown using centerline height Dimension D, except sizes 300-365. Use Dimension DG for 300-365 when BHD discharge is required, otherwise Dimension D will be supplied.

FAN SIZE	A	B	BC	BH	C	CA	CC	D	DG	FF	FG	FH	FJ	FK	FL	FN	G	GC	H	HA
165	17.31	13.06	19.50	0.44	17.88	17.50	20.75	21.00	-	2	4.03	2.91	3.00	20	16	4	21.25	10.63	35.75	15.13
182	19.25	14.44	21.25	0.56	19.63	19.25	22.50	23.00	-	2	3.00	3.34	3.25	22	16	5	23.50	11.75	37.38	19.50
200	21.06	15.81	23.38	0.56	21.50	21.13	24.38	25.00	-	2	3.91	3.78	3.50	22	16	5	25.00	12.50	40.50	20.56
222	23.44	17.50	25.50	0.56	23.88	23.50	27.75	27.50	-	2	3.09	4.13	4.00	24	24	6	27.38	13.69	42.63	21.94
245	25.81	19.25	27.75	0.56	26.19	25.81	30.06	30.00	-	3	4.28	3.00	3.00	28	24	6	29.63	14.81	45.19	23.50
270	28.50	21.19	30.25	0.56	28.63	28.25	32.50	32.50	-	3	3.63	3.22	3.38	30	24	7	32.25	16.13	47.38	25.19
300	31.63	23.56	33.63	0.81	31.75	31.38	35.63	31.00	36.00	3	3.19	3.66	3.75	32	24	8	35.50	17.75	50.56	29.06
330	34.94	25.81	37.25	0.81	34.88	34.50	38.75	34.00	39.00	3	2.84	4.28	4.00	34	32	9	39.25	19.63	54.81	31.00
365	38.50	28.63	40.75	0.81	38.63	38.25	42.50	37.00	43.00	4	2.63	3.56	3.38	40	32	10	42.75	21.38	59.13	33.50

FAN SIZE	HB	HC	HD	HE	HF	HG	HH	J	K	KA	KL	KS	L	M	N	P	Q	SD	SE
165	24.88	20.06	16.44	15.63	14.75	14.00	13.13	12.94	8.06	8.69	5.00	.50 x .25	16.25	8.50	0.88	31.69	8.94	1.94	5.50
182	29.38	22.00	18.13	17.19	16.19	15.31	14.31	13.63	8.75	9.38	5.75	.50 x .25	16.50	9.13	0.88	33.63	9.88	2.19	6.50
200	31.38	23.81	19.88	18.81	17.69	16.69	15.56	14.31	9.44	10.06	5.75	.50 x .25	18.25	10.13	0.88	36.06	10.81	2.19	6.50
222	34.06	26.19	21.69	20.56	19.38	18.31	17.13	15.13	10.25	10.88	6.75	.63 x .31	18.75	11.25	0.88	38.38	12.00	2.44	7.50
245	36.81	28.56	23.75	22.50	21.25	20.00	18.69	16.00	11.13	11.75	6.75	.63 x .31	19.50	12.38	0.88	40.00	13.19	2.44	7.50
270	39.50	31.25	26.13	24.69	23.25	21.94	20.50	17.00	12.13	12.75	6.75	.63 x .31	19.75	13.63	0.88	41.31	14.50	2.69	7.50
300	44.88	34.38	28.75	27.19	25.63	24.19	22.63	18.19	13.38	14.00	6.75	.63 x .31	20.50	15.13	0.88	43.25	16.06	2.69	7.50
330	48.56	37.69	31.56	29.81	28.06	26.44	24.69	19.31	14.50	15.13	8.25	.75 x .38	22.50	16.63	0.88	47.88	17.75	2.94	9.00
365	52.88	41.25	34.88	32.94	31.00	29.19	27.25	20.69	15.88	16.50	9.25	.88 x .44	24.00	18.63	0.88	51.75	19.50	3.44	10.00

BC1000150-F

DIMENSIONAL DATA

Arrg. 1 M1/M2, Sizes 402 – 600 Non-Rotatable

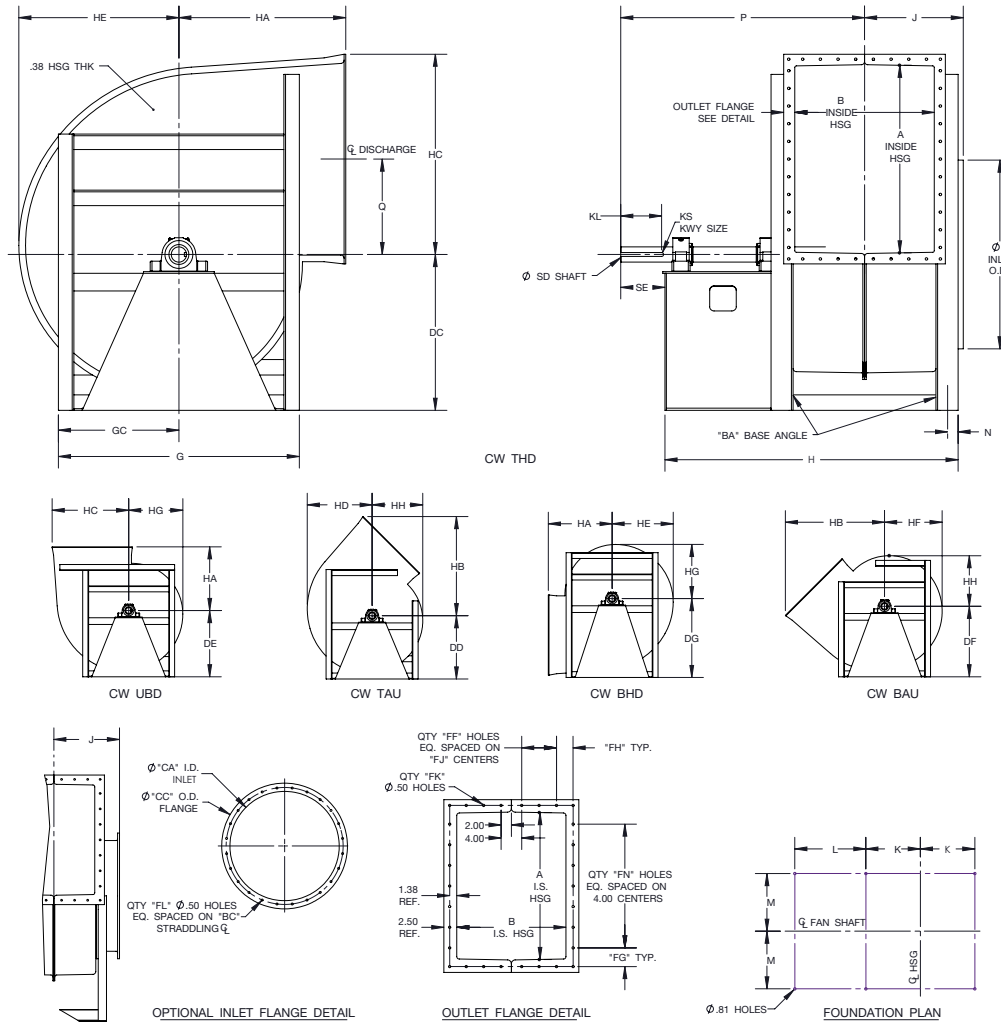

Notes:

1. Outlet flanges are included on all discharges. Drilling is optional.
2. CW rotation is shown, CCW rotation is similar but opposite.

FAN SIZE	A	B	BA	BC	C	CA	CC	DC	DD	DE	DF	DG	FF	FG	FH	FJ	FK	FL	FN	G	GC
402	42.44	31.56	3.5 x 5.0	44.63	42.69	42.19	46.44	35.25	37.50	39.25	41.75	46.75	4	2.59	3.16	4.00	42.00	32.00	11	54.50	27.25
445	46.94	34.94	4.0 x 6.0	49.00	47.13	46.63	51.88	37.75	40.75	41.75	45.25	51.25	5	2.84	2.84	3.50	48.00	40.00	12	61.00	30.50
490	51.75	38.38	4.0 x 6.0	53.75	51.88	51.38	56.63	41.25	44.50	46.25	49.75	56.50	5	3.25	3.56	3.75	50.00	40.00	13	65.75	32.88
542	57.19	42.63	4.0 x 6.0	59.25	57.38	56.88	62.13	45.75	48.75	51.25	55.00	61.50	6	3.97	3.19	3.50	56.00	48.00	14	71.25	35.63
600	63.31	47.06	4.0 x 6.0	65.25	63.38	62.88	68.13	50.25	53.50	56.25	59.75	67.50	6	3.03	3.53	3.88	60.00	48.00	16	77.25	38.63

FAN SIZE	H	HA	HB	HC	HD	HE	HF	HG	HH	J	K	KL	KS	L	M	N	P	Q	SD	SE
402	66.31	37.75	58.80	45.31	38.44	36.25	34.19	32.13	30.06	22.38	18.81	9.25	.88 x .44	24.50	19.88	2.38	55.19	21.63	3.44	10.00
445	74.69	42.63	65.13	49.81	42.25	39.81	37.56	35.31	33.06	24.06	21.00	9.25	1.00 x .50	28.00	21.38	2.88	60.88	23.88	3.94	10.00
490	80.13	45.50	70.56	54.63	46.44	43.75	41.25	38.75	36.25	25.75	22.69	9.25	1.00 x .50	30.00	23.88	2.88	64.56	26.25	3.94	10.00
542	87.38	49.06	76.91	60.06	51.25	48.25	45.50	42.75	40.00	27.88	25.19	9.25	1.00 x .50	32.69	26.63	2.88	69.69	29.00	4.44	10.00
600	92.81	52.94	84.00	66.19	56.63	53.31	50.25	47.19	44.13	30.13	27.06	9.25	1.25 x .63	34.00	29.63	2.88	72.91	32.06	4.94	10.00

BC1000151-D

Arrg. 1 H1/H2, Sizes 165 – 365 Rotatable

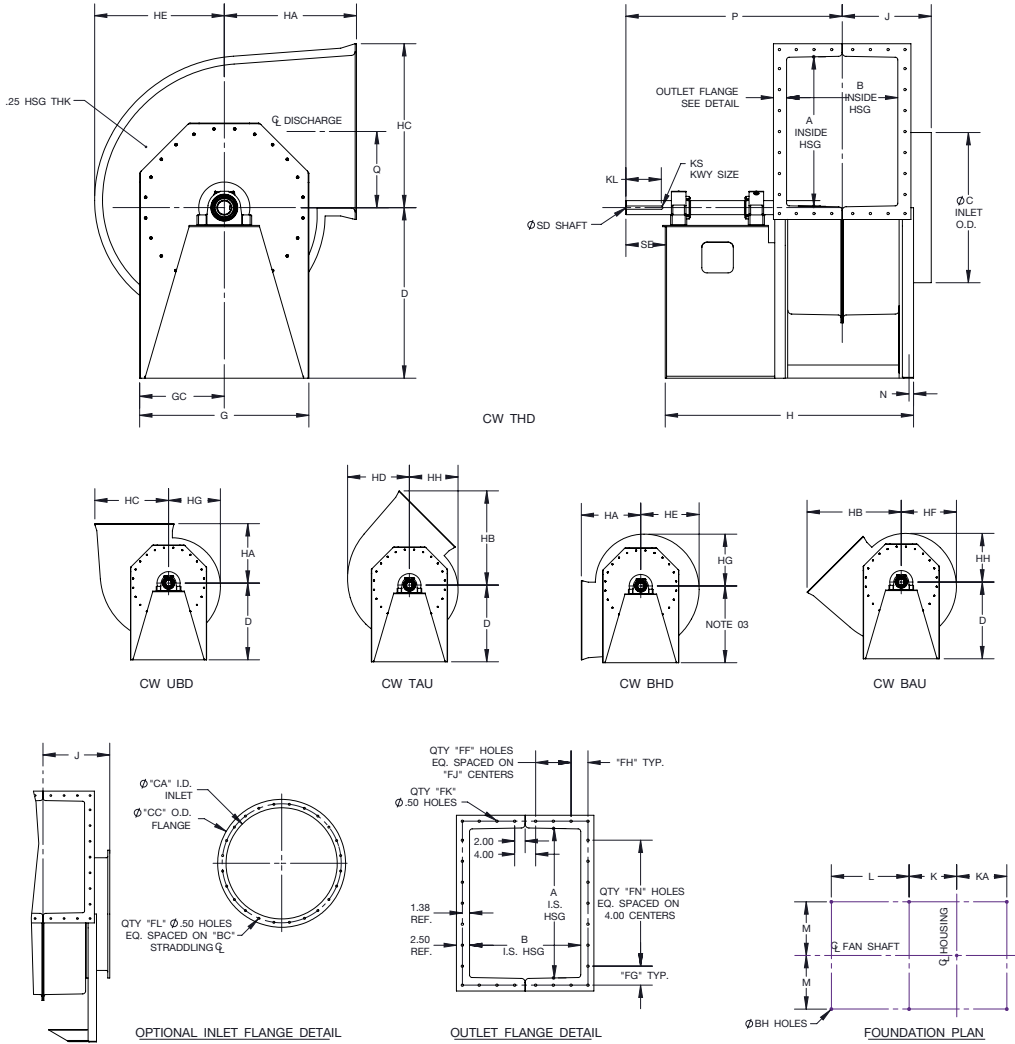

Notes:

1. Outlet flanges are included on all discharges. Drilling is optional.
2. CW rotation is shown, CCW rotation is similar but opposite.
3. All units are rotatable to all positions shown using centerline height Dimension D, except sizes 300-365. Use Dimension DG for 300-365 when BHD discharge is required, otherwise Dimension D will be supplied.

FAN SIZE	A	B	BC	BH	C	CA	CC	D	DG	FF	FG	FH	FJ	FK	FL	FN	G	GC	H	HA
165	17.31	11.75	19.50	0.44	17.88	17.50	20.75	21.00	-	2	4.03	2.63	2.63	20	16	4	21.25	10.63	34.44	15.13
182	19.25	13.00	21.25	0.56	19.63	19.25	22.50	23.00	-	2	3.00	2.94	2.94	22	16	5	23.50	11.75	36.38	19.50
200	21.06	14.19	23.38	0.56	21.50	21.13	24.38	25.00	-	2	3.91	3.22	3.25	22	16	5	25.00	12.50	38.88	20.56
222	23.44	15.75	25.50	0.56	23.88	23.50	27.75	27.50	-	2	3.09	3.63	3.63	24	24	6	27.38	13.69	40.88	21.94
245	25.81	17.31	27.75	0.56	26.19	25.81	30.06	30.00	-	2	4.28	4.03	4.00	24	24	6	29.63	14.81	43.25	23.50
270	28.50	19.06	30.25	0.56	28.63	28.25	32.50	32.50	-	3	3.63	2.91	3.00	30	24	7	32.25	16.13	45.25	25.19
300	31.63	21.19	33.63	0.81	31.75	31.38	35.63	31.00	36.00	3	3.19	3.22	3.38	32	24	8	35.50	17.75	48.19	29.06
330	34.94	23.19	37.25	0.81	34.88	34.50	38.75	34.00	39.00	3	2.84	3.47	3.75	34	32	9	39.25	19.63	52.19	31.00
365	38.50	25.75	40.75	0.81	38.63	38.25	42.50	37.00	43.00	4	2.63	3.25	3.00	40	32	10	42.75	21.38	56.25	33.50

FAN SIZE	HB	HC	HD	HE	HF	HG	HH	J	K	KA	KL	KS	L	M	N	P	Q	SD	SE
165	24.88	20.06	16.44	15.63	14.75	14.00	13.13	12.31	7.38	8.06	5.00	.50 x .25	16.25	8.50	0.88	31.06	8.94	1.94	5.50
182	29.38	22.00	18.13	17.19	16.19	15.31	14.31	12.94	8.06	8.63	5.75	.50 x .25	16.50	9.13	0.88	32.94	9.88	2.19	6.50
200	31.38	23.81	19.88	18.81	17.69	16.69	15.56	13.50	8.63	9.25	5.75	.50 x .25	18.25	10.13	0.88	35.25	10.81	2.19	6.50
222	34.06	26.19	21.69	20.56	19.38	18.31	17.13	14.25	9.38	10.06	6.75	.63 x .31	18.75	11.25	0.88	37.50	12.00	2.44	7.50
245	36.81	28.56	23.75	22.50	21.25	20.00	18.69	15.06	10.19	10.81	6.75	.63 x .31	19.50	12.38	0.88	39.06	13.19	2.44	7.50
270	39.50	31.25	26.13	24.69	23.25	21.94	20.50	15.94	11.06	11.69	6.75	.63 x .31	19.75	13.63	0.88	40.25	14.50	2.69	7.50
300	44.88	34.38	28.75	27.19	25.63	24.19	22.63	17.00	12.19	12.81	6.75	.63 x .31	20.50	15.13	0.88	42.06	16.06	2.69	7.50
330	48.56	37.69	31.56	29.81	28.06	26.44	24.69	18.00	13.19	13.81	8.25	.75 x .38	22.50	16.63	0.88	46.56	17.75	2.94	9.00
365	52.88	41.25	34.88	32.94	31.00	29.19	27.25	19.25	14.11	15.06	9.25	.88 x .44	24.00	18.63	0.88	49.69	19.50	3.44	10.00

BC1000157-F

DIMENSIONAL DATA

Arrg. 1 H1/H2, Sizes 402 – 600 Non-Rotatable

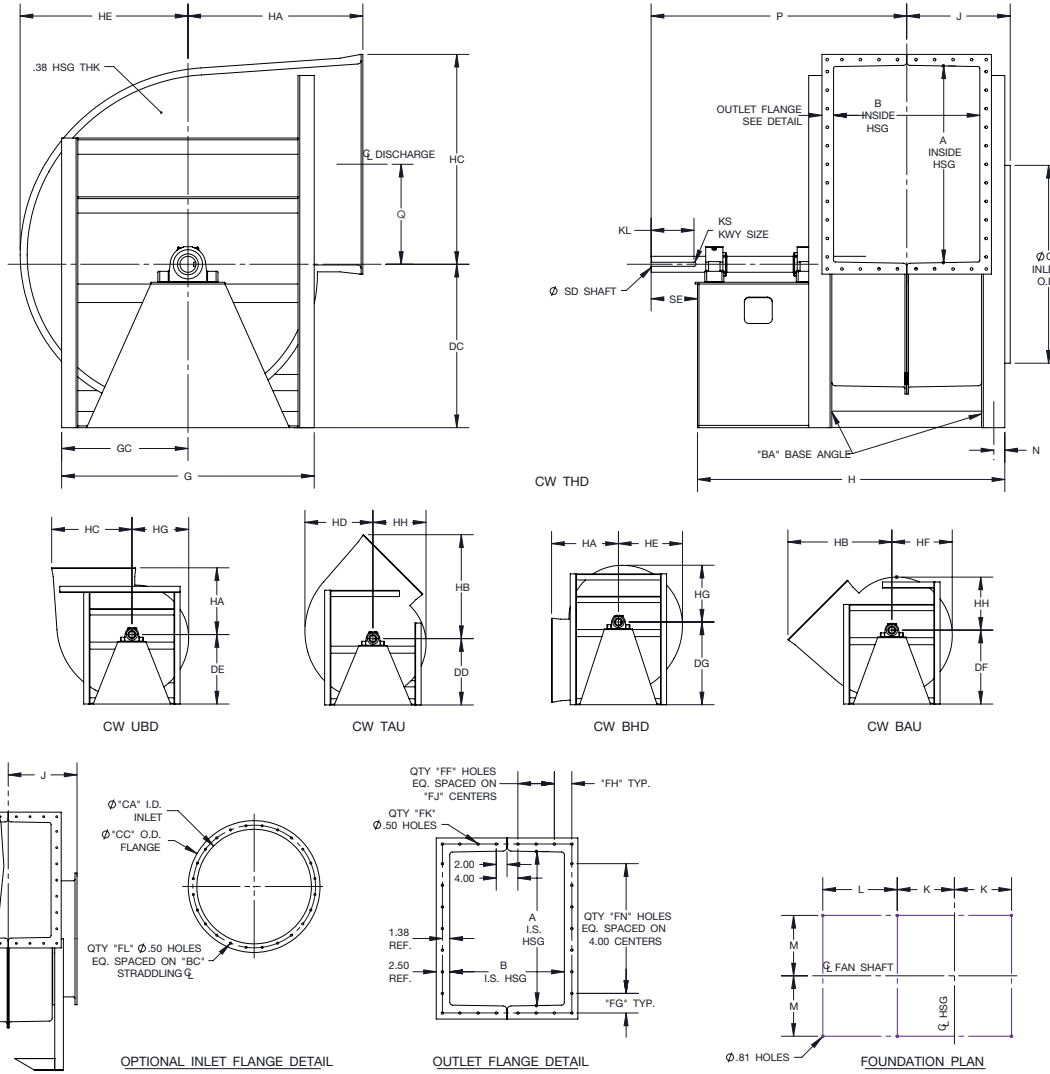

Notes:

1. Outlet flanges are included on all discharges. Drilling is optional.
2. CW rotation is shown, CCW rotation is similar but opposite.

FAN SIZE	A	B	BA	BC	C	CA	CC	DC	DD	DE	DF	DG	FF	FG	FH	FJ	FK	FL	FN	G	GC
402	42.44	28.38	3.5 x 5.0	44.63	42.69	42.19	46.44	35.25	37.50	39.25	41.75	46.75	4	2.59	3.44	3.38	42	32	11	54.50	27.25
445	46.94	31.44	4.0 x 6.0	49.00	47.13	46.63	51.88	37.75	40.75	41.75	45.25	51.25	4	2.84	3.84	3.75	44	40	12	61.00	30.50
490	51.75	34.50	4.0 x 6.0	53.75	51.88	51.38	56.63	41.25	44.50	46.25	49.75	56.50	5	3.25	3.13	3.38	50	40	13	65.75	32.88
542	57.19	38.25	4.0 x 6.0	59.25	57.38	56.88	62.13	45.75	48.75	51.25	55.00	61.50	5	3.97	3.75	3.69	56	48	14	71.25	35.63
600	63.31	42.31	4.0 x 6.0	65.25	63.38	62.88	68.13	50.25	53.50	56.25	59.75	67.50	6	3.03	3.66	3.38	60	48	16	77.25	38.63

FAN SIZE	H	HA	HB	HC	HD	HE	HF	HG	HH	J	K	KL	KS	L	M	N	P	Q	SD	SE
402	63.13	37.75	58.80	45.31	38.44	36.25	34.19	32.13	30.06	20.81	17.19	9.25	.88 x .44	24.50	19.88	2.38	53.63	21.63	3.44	10.00
445	71.19	42.63	65.13	49.81	42.25	39.81	37.56	35.31	33.06	22.31	19.25	9.25	1.00 x .50	28.00	21.38	2.88	59.13	23.88	3.94	10.00
490	76.25	45.50	70.56	54.63	46.44	43.75	41.25	38.75	36.25	23.81	20.75	9.25	1.00 x .50	30.00	23.88	2.88	63.63	26.25	3.94	10.00
542	83.00	49.06	76.91	60.06	51.25	48.25	45.50	42.75	40.00	25.69	22.63	9.25	1.00 x .50	32.69	26.63	2.88	67.50	29.00	4.44	10.00
600	88.06	52.94	84.00	66.19	56.63	53.31	50.25	47.19	44.13	27.75	24.69	9.25	1.25 x .63	34.00	29.63	2.88	70.56	32.06	4.94	10.00

BC1000158-E

Arrg. 9 M1/M2, Sizes 165 – 365 Rotatable

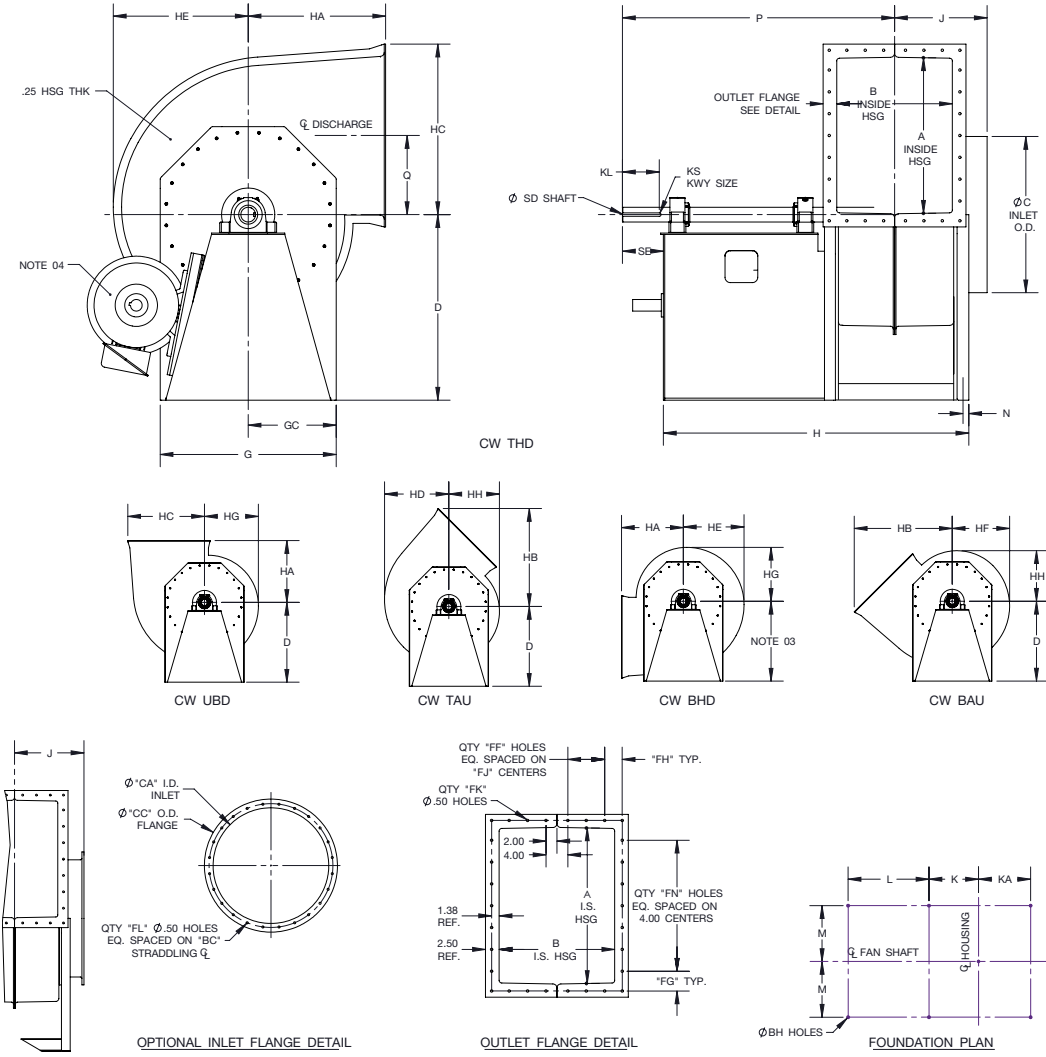

Notes:

1. Outlet flanges are included on all discharges. Drilling is optional.
2. CW rotation is shown, CCW rotation is similar but opposite.
3. All units are rotatable to all positions shown using centerline height Dimension D, except sizes 300-365. Use Dimension DG for 300-365 when BHD discharge is required, otherwise Dimension D will be supplied.
4. Standard Arr. 9 motor location is on the left for CW rotation and on the right for CCW rotation (unless otherwise specified). Dimension FR is maximum motor frame.

FAN SIZE	A	B	BC	BH	C	CA	CC	D	DG	FF	FG	FH	FJ	FK	FL	FN	FR	G	GC	H
165	17.31	13.06	19.50	0.44	17.88	17.50	20.75	27.00	-	2	4.03	2.91	3.00	20	16	4	286T	21.25	10.63	46.13
182	19.25	14.44	21.25	0.56	19.63	19.25	22.50	30.50	-	2	3.00	3.34	3.25	22	16	5	326T	23.50	11.75	49.75
200	21.06	15.81	23.38	0.56	21.50	21.13	24.38	31.00	-	2	3.91	3.78	3.50	22	16	5	326T	25.00	12.50	51.13
222	23.44	17.50	25.50	0.56	23.88	23.50	27.75	33.75	-	2	3.09	4.13	4.00	24	24	6	365T	27.38	13.69	53.94
245	25.81	19.25	27.75	0.56	26.19	25.81	30.06	34.00	-	3	4.28	3.00	3.00	28	24	6	365T	29.63	14.81	55.38
270	28.50	21.19	30.25	0.56	28.63	28.25	32.50	34.00	-	3	3.63	3.22	3.38	30	24	7	365T	32.25	16.13	57.38
300	31.63	23.56	33.63	0.81	31.75	31.38	35.63	34.75	36.00	3	3.19	3.66	3.75	32	24	8	365T	35.50	17.75	60.81
330	34.94	25.81	37.25	0.81	34.88	34.50	38.75	37.75	39.00	3	2.84	4.28	4.00	34	32	9	405T	39.25	19.63	69.69
365	38.50	28.63	40.75	0.81	38.63	38.25	42.50	41.00	43.00	4	2.63	3.56	3.38	40	32	10	405T	42.75	21.38	78.81

FAN SIZE	HA	HB	HC	HD	HE	HF	HG	HH	J	K	KA	KL	KS	L	M	N	P	Q	SD	SE
165	15.13	24.88	20.06	16.44	15.63	14.75	14.00	13.13	12.94	8.06	8.69	5.00	.50 x .25	25.25	8.50	0.88	40.69	8.94	1.94	5.50
182	19.50	29.38	22.00	18.13	17.19	16.19	15.31	14.31	13.63	8.75	9.38	5.75	.50 x .25	27.50	9.13	0.88	44.63	9.88	2.19	6.50
200	20.56	31.38	23.81	19.88	18.81	17.69	16.69	15.56	14.31	9.44	10.06	5.75	.50 x .25	27.50	10.13	0.88	45.31	10.81	2.19	6.50
222	21.94	34.06	26.19	21.69	20.56	19.38	18.31	17.13	15.13	10.25	10.88	6.75	.63 x .31	28.63	11.25	0.88	48.25	12.00	2.44	7.50
245	23.50	36.81	28.56	23.75	22.50	21.25	20.00	18.69	16.00	11.13	11.75	6.75	.63 x .31	28.38	12.38	0.88	48.88	13.19	2.44	7.50
270	25.19	39.50	31.25	26.13	24.69	23.25	21.94	20.50	17.00	12.13	12.75	6.75	.63 x .31	28.38	13.63	0.88	49.88	14.50	2.69	7.50
300	29.06	44.88	34.38	28.75	27.19	25.63	24.19	22.63	18.19	13.38	14.00	6.75	.63 x .31	29.38	15.13	0.88	52.13	16.06	2.69	7.50
330	31.00	48.56	37.69	31.56	29.81	28.06	26.44	24.69	19.31	14.50	15.13	8.25	.75 x .38	36.00	16.63	0.88	61.38	17.75	2.94	9.00
365	33.50	52.88	41.25	34.88	32.94	31.00	29.19	27.25	20.69	15.88	16.50	9.25	.88 x .44	42.13	18.63	0.88	68.88	19.50	3.44	10.00

BC1000155-F

DIMENSIONAL DATA

Arrg. 9 M1/M2, Sizes 402 – 600 Non-Rotatable

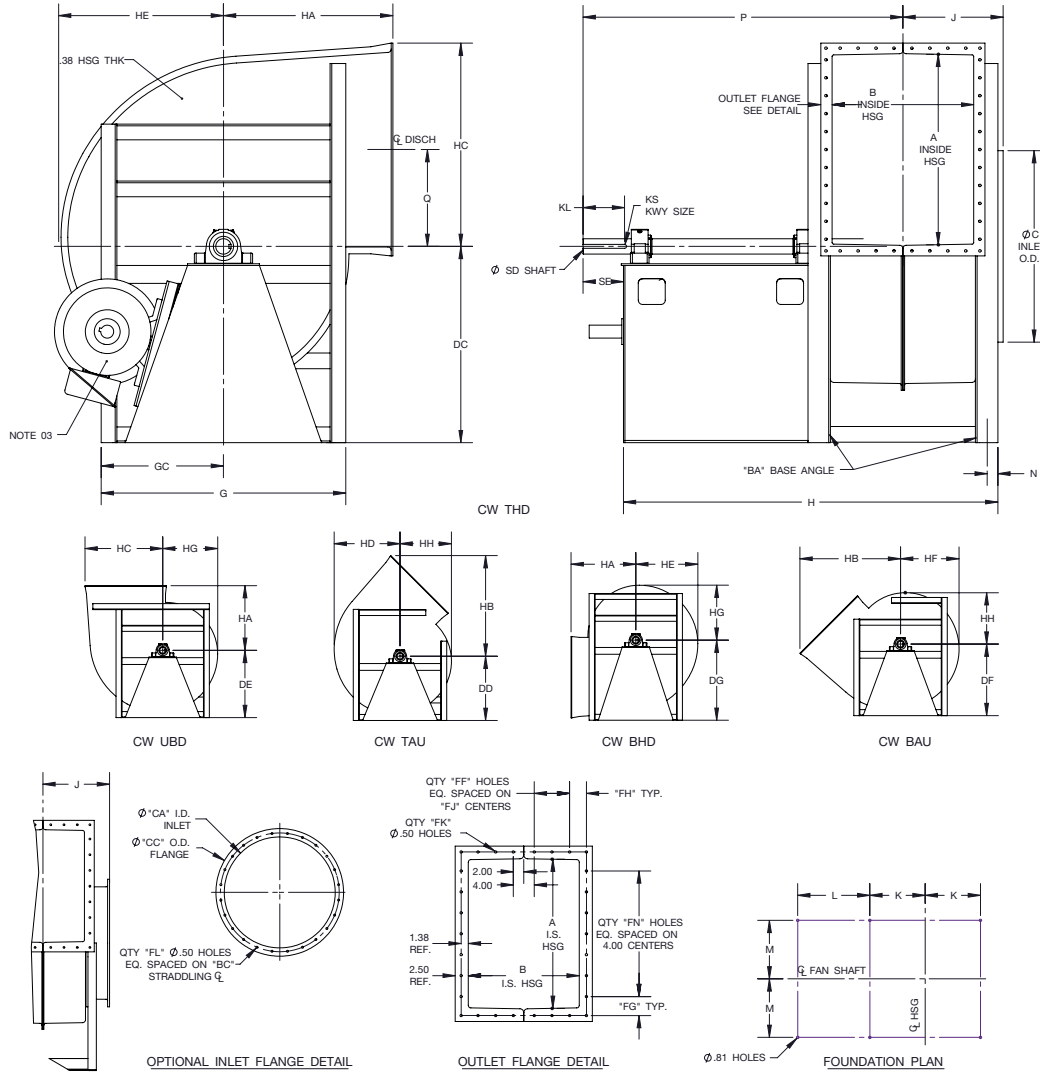

Notes:

1. Outlet flanges are included on all discharges. Drilling is optional.
2. CW rotation is shown, CCW rotation is similar but opposite.
3. Standard Arr. 9 motor location is on the left for CW rotation and on the right for CCW rotation. Dimension FR is maximum motor frame.

FAN SIZE	A	B	BA	BC	C	CA	CC	DC	DD	DE	DF	DG	FF	FG	FH	FJ	FK	FL	FN	FR	G
402	42.44	31.56	3.5 x 5.0	44.63	42.69	42.19	46.44	43.75	43.75	43.75	43.75	46.75	4	2.59	3.16	4.00	42	32	11	405T	54.50
445	46.94	34.94	4.0 x 6.0	49.00	47.13	46.63	51.88	44.75	44.75	44.75	45.25	50.75	5	2.84	2.84	3.50	48	40	12	405T	61.00
490	51.75	38.38	4.0 x 6.0	53.75	51.88	51.38	56.63	44.75	44.75	46.25	49.75	55.50	5	3.25	3.56	3.75	50	40	13	405T	65.75
542	57.19	42.63	4.0 x 6.0	59.25	57.38	56.88	62.13	45.75	48.75	51.25	55.00	61.00	6	3.97	3.19	3.50	56	48	14	405T	71.25
600	63.31	47.06	4.0 x 6.0	65.25	63.38	62.88	68.13	50.25	53.50	56.25	59.75	66.50	6	3.03	3.53	3.88	60	48	16	405T	77.25

FAN SIZE	GC	H	HA	HB	HC	HD	HE	HF	HG	HH	J	K	KL	KS	L	M	N	P	Q	SD	SE
402	27.25	85.00	37.75	58.80	45.31	38.44	36.25	34.19	32.13	30.06	22.38	18.81	9.25	.88 x .44	41.63	19.88	2.38	72.31	21.63	3.44	10.00
445	30.50	90.00	42.63	65.13	49.81	42.25	39.81	37.56	35.31	33.06	24.06	21.00	9.25	1.00 x .50	41.75	21.38	2.88	74.63	23.88	3.94	10.00
490	32.88	93.44	45.50	70.56	54.63	46.44	43.75	41.25	38.75	36.25	25.75	22.69	9.25	1.00 x .50	41.75	23.88	2.88	76.31	26.25	3.94	10.00
542	35.63	97.69	49.06	76.91	60.06	51.25	48.25	45.50	42.75	40.00	27.88	25.19	9.25	1.00 x .50	41.75	26.63	2.88	78.44	29.00	4.44	10.00
600	38.63	102.13	52.94	84.00	66.19	56.63	53.31	50.25	47.19	44.13	30.13	27.06	9.25	1.25 x .63	41.75	29.63	2.88	80.69	32.06	4.94	10.00

BC1000156-D

Arrg. 9 H1/H2, Sizes 165 – 365 Rotatable

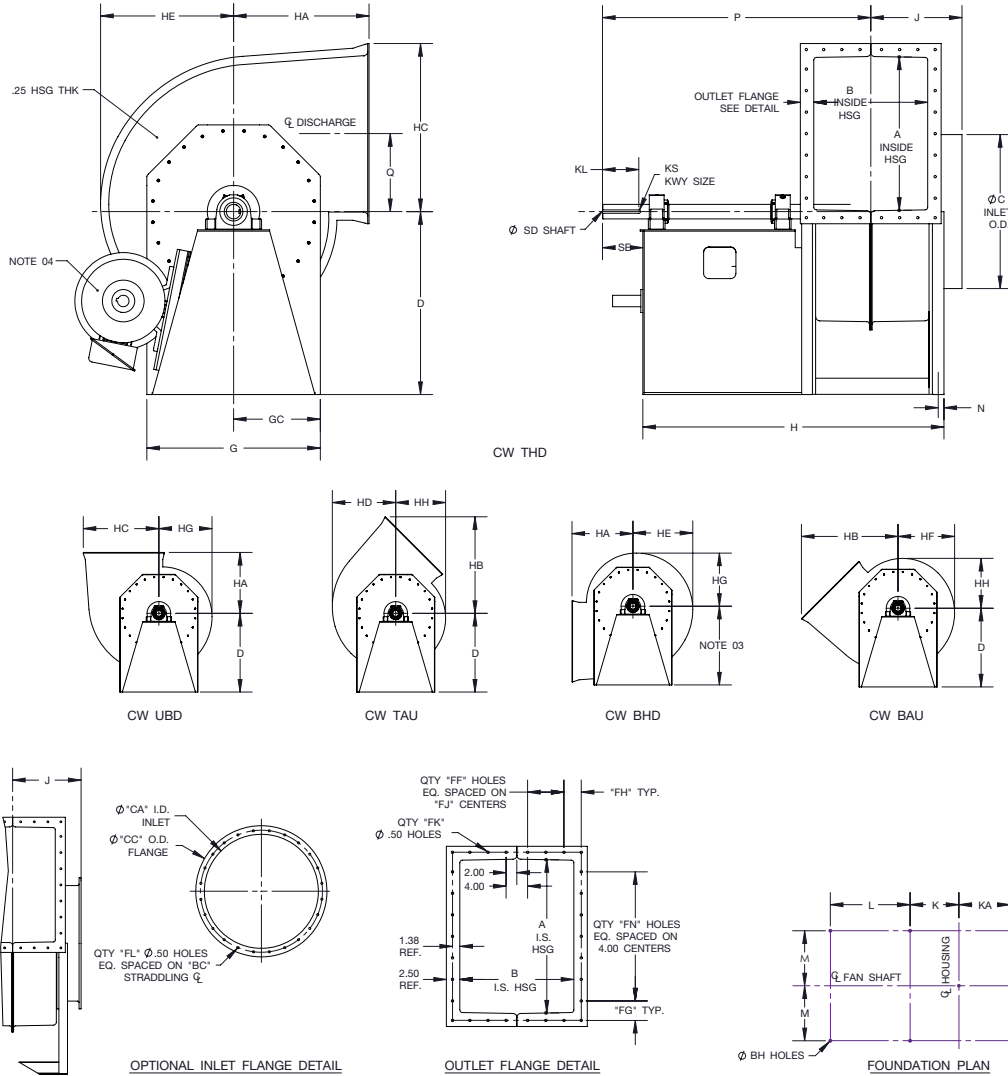

Notes:

1. Outlet flanges are included on all discharges. Drilling is optional.
2. CW rotation is shown, CCW rotation is similar but opposite.
3. All units are rotatable to all positions shown using centerline height Dimension D, except sizes 300-365. Use Dimension DG for 300-365 when BHD discharge is required, otherwise Dimension D will be supplied.
4. Standard Arr. 9 motor location is on the left for CW rotation and on the right for CCW rotation (unless otherwise specified). Dimension FR is maximum motor frame.

FAN SIZE	A	B	BC	BH	C	CA	CC	D	DG	FF	FG	FH	FJ	FK	FL	FN	FR	G	GC	H
165	17.31	11.75	19.50	0.44	17.88	17.50	20.75	27.00	-	2	4.03	2.63	2.63	20	16	4	286T	21.25	10.63	44.81
182	19.25	13.00	21.25	0.56	19.63	19.25	22.50	30.50	-	2	3.00	2.94	2.94	22	16	5	326T	23.50	11.75	48.31
200	21.06	14.19	23.38	0.56	21.50	21.13	24.38	31.00	-	2	3.91	3.22	3.25	22	16	5	326T	25.00	12.50	49.50
222	23.44	15.75	25.50	0.56	23.88	23.50	27.75	33.75	-	2	3.09	3.63	3.63	24	24	6	365T	27.38	13.69	52.19
245	25.81	17.31	27.75	0.56	26.19	25.81	30.06	34.00	-	2	4.28	4.03	4.00	24	24	6	365T	29.63	14.81	53.44
270	28.50	19.06	30.25	0.56	28.63	28.25	32.50	34.00	-	3	3.63	2.91	3.00	30	24	7	365T	32.25	16.13	55.25
300	31.63	21.19	33.63	0.81	31.75	31.38	35.63	34.75	36.00	3	3.19	3.22	3.38	32	24	8	365T	35.50	17.75	58.44
330	34.94	23.19	37.25	0.81	34.88	34.50	38.75	37.75	39.00	3	2.84	3.47	3.75	34	32	9	405T	39.25	19.63	67.06
365	38.50	25.75	40.75	0.81	38.63	38.25	42.50	41.00	43.00	4	2.63	3.25	3.00	40	32	10	405T	42.75	21.38	75.94

FAN SIZE	HA	HB	HC	HD	HE	HF	HG	HH	J	K	KA	KL	KS	L	M	N	P	Q	SD	SE
165	15.13	24.88	20.06	16.44	15.63	14.75	14.00	13.13	12.31	7.38	8.06	5.00	.50 x .25	25.25	8.50	0.88	40.06	8.94	1.94	5.50
182	19.50	29.38	22.00	18.13	17.19	16.19	15.31	14.31	12.94	8.06	8.63	5.75	.50 x .25	27.50	9.13	0.88	43.94	9.88	2.19	6.50
200	20.56	31.38	23.81	19.88	18.81	17.69	16.69	15.56	13.50	8.63	9.25	5.75	.50 x .25	27.50	10.13	0.88	44.50	10.81	2.19	6.50
222	21.94	34.06	26.19	21.69	20.56	19.38	18.31	17.13	14.25	9.38	10.06	6.75	.63 x .31	28.63	11.25	0.88	47.38	12.00	2.44	7.50
245	23.50	36.81	28.56	23.75	22.50	21.25	20.00	18.69	15.06	10.19	10.81	6.75	.63 x .31	28.38	12.38	0.88	47.94	13.19	2.44	7.50
270	25.19	39.50	31.25	26.13	24.69	23.25	21.94	20.50	15.94	11.06	11.69	6.75	.63 x .31	28.38	13.63	0.88	48.81	14.50	2.69	7.50
300	29.06	44.88	34.38	28.75	27.19	25.63	24.19	22.63	17.00	12.19	12.81	6.75	.63 x .31	29.38	15.13	0.88	50.94	16.06	2.69	7.50
330	31.00	48.56	37.69	31.56	29.81	28.06	26.44	24.69	18.00	13.19	13.81	8.25	.75 x .38	36.00	16.63	0.88	60.06	17.75	2.94	9.00
365	33.50	52.88	41.25	34.88	32.94	31.00	29.19	27.25	19.25	14.44	15.06	9.25	.88 x .44	42.13	18.63	0.88	67.44	19.50	3.44	10.00

BC1000162-F

DIMENSIONAL DATA

Arrg. 9 H1/H2, Sizes 402 – 600 Non-Rotatable

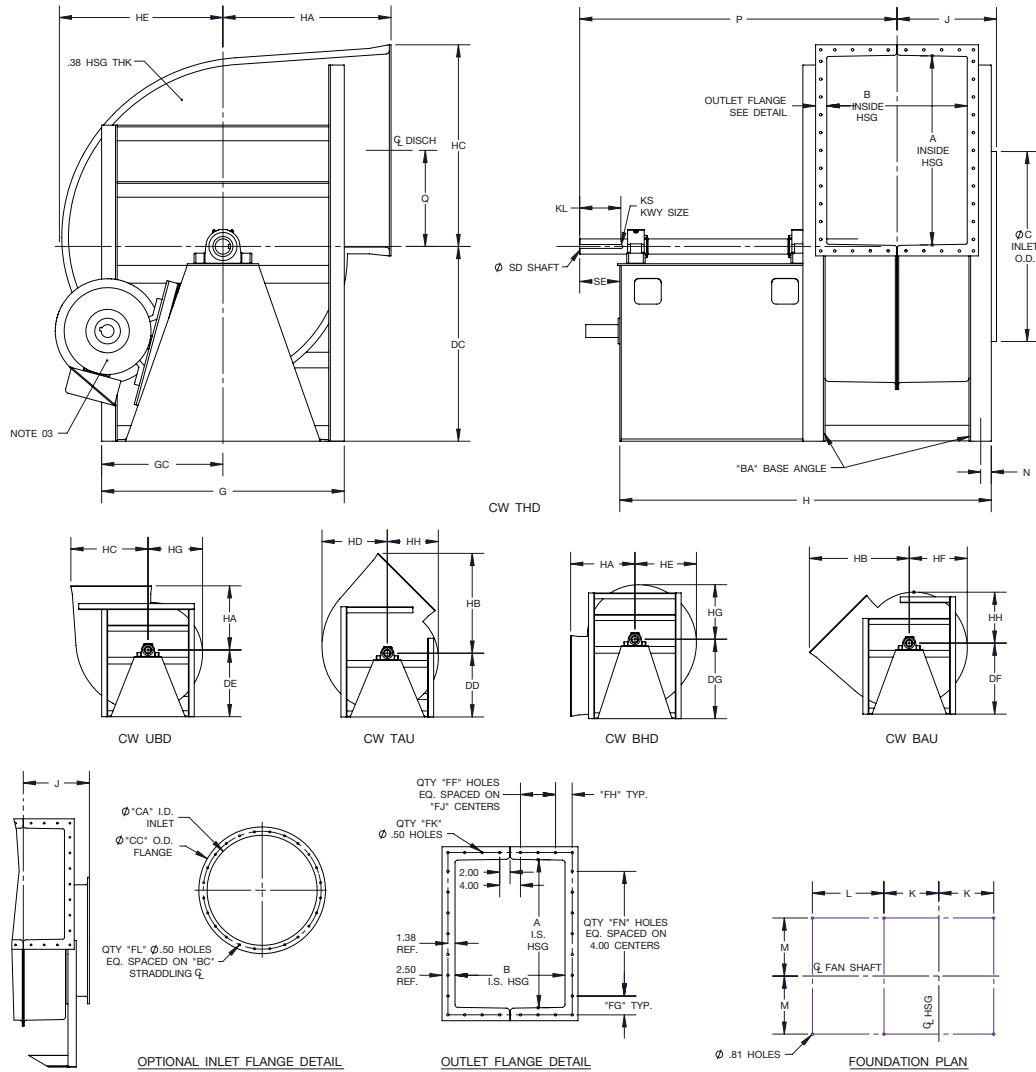

Notes:

1. Outlet flanges are included on all discharges. Drilling is optional.
2. CW rotation is shown, CCW rotation is similar but opposite.
3. Standard Arr. 9 motor location is on the left for CW rotation and on the right for CCW rotation (unless otherwise specified). Dimension FR is maximum motor frame.

FAN SIZE	A	B	BA	BC	C	CA	CC	DC	DD	DE	DF	DG	FF	FG	FH	FJ	FK	FL	FN	FR	G
402	42.44	28.38	3.5 x 5.0	44.63	42.69	42.19	46.44	43.75	43.75	43.75	43.75	46.75	4	2.59	3.44	3.38	42	32	11	405T	54.50
445	46.94	31.44	4.0 x 6.0	49.00	47.13	46.63	51.88	44.75	44.75	44.75	45.25	50.75	4	2.84	3.84	3.75	44	40	12	405T	61.00
490	51.75	34.50	4.0 x 6.0	53.75	51.88	51.38	56.63	44.75	44.75	46.25	49.75	55.50	5	3.25	3.13	3.38	50	40	13	405T	65.75
542	57.19	38.25	4.0 x 6.0	59.25	57.38	56.88	62.13	45.75	48.75	51.25	55.00	61.00	5	3.97	3.75	3.69	52	48	14	405T	71.25
600	63.31	42.31	4.0 x 6.0	65.25	63.38	62.88	68.13	50.25	53.50	56.25	59.75	66.50	6	3.03	3.66	3.38	60	48	16	405T	77.25

FAN SIZE	GC	H	HA	HB	HC	HD	HE	HF	HG	HH	J	K	KL	KS	L	M	N	P	Q	SD	SE
402	27.25	81.81	37.75	58.80	45.31	38.44	36.25	34.19	32.13	30.06	20.81	17.19	9.25	.88 x .44	41.63	19.88	2.38	70.75	21.63	3.44	10.00
445	30.50	86.50	42.63	65.13	49.81	42.25	39.81	37.56	35.31	33.06	22.31	19.25	9.25	1.00 x .50	41.75	21.38	2.88	72.88	23.88	3.94	10.00
490	32.88	89.56	45.50	70.56	54.63	46.44	43.75	41.25	38.75	36.25	23.81	20.75	9.25	1.00 x .50	41.75	23.88	2.88	74.38	26.25	3.94	10.00
542	35.63	93.31	49.06	76.91	60.06	51.25	48.25	45.50	42.75	40.00	25.69	22.63	9.25	1.00 x .50	41.75	26.63	2.88	76.25	29.00	4.44	10.00
600	38.63	97.38	52.94	84.00	66.19	56.63	53.31	50.25	47.19	44.13	27.75	24.69	9.25	1.25 x .63	41.75	29.63	2.88	78.31	32.06	4.94	10.00

BC1000163-E

Arrg. 9F M1/M2, Sizes 165 – 365 Rotatable

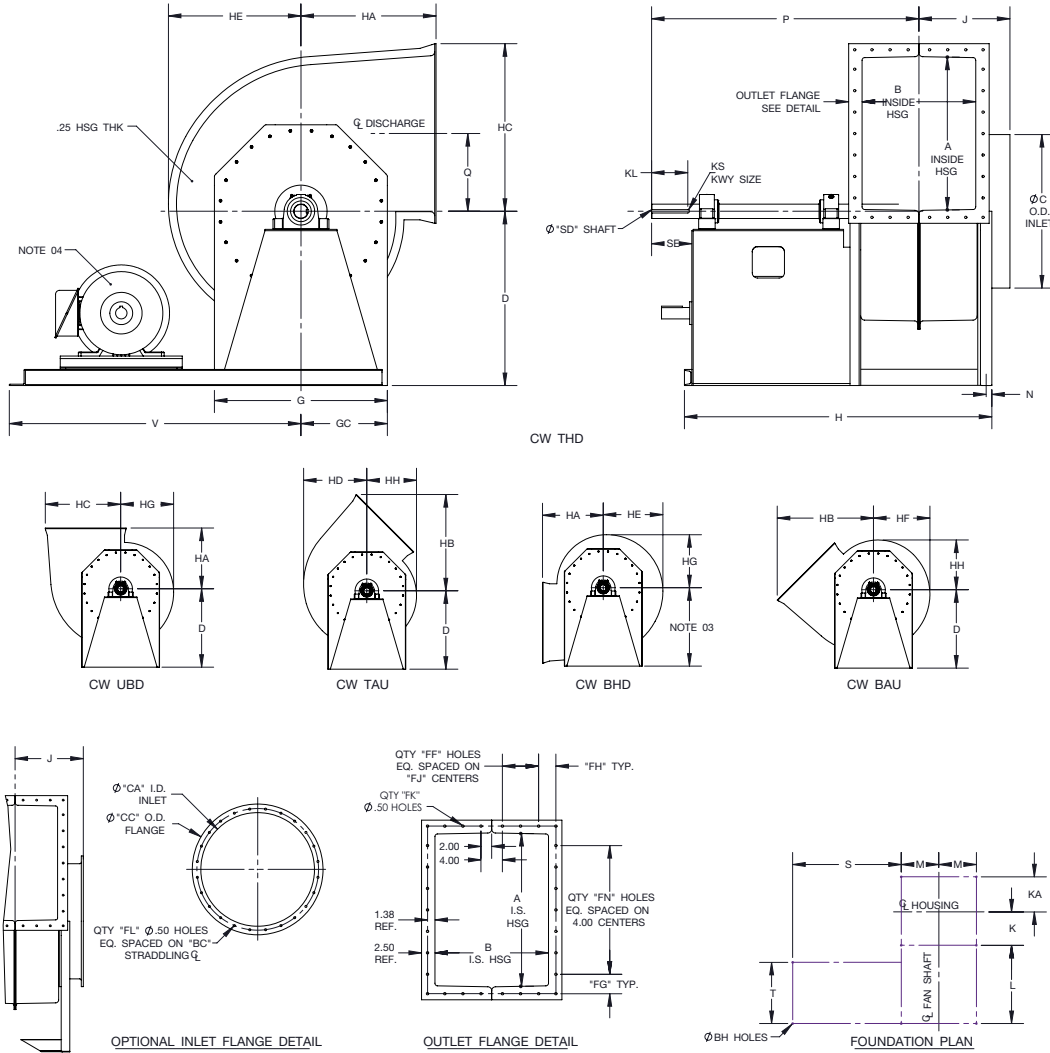

Notes:

1. Outlet flanges are included on all discharges. Drilling is optional.
2. CW rotation is shown, CCW rotation is similar but opposite.
3. All units are rotatable to all positions shown using centerline height Dimension D, except sizes 300-365. Use Dimension DG for 300-365 when BHD discharge is required, otherwise Dimension D will be supplied.
4. Standard Arr. 9F motor location is on the left for CW rotation and on the right for CCW rotation (unless otherwise specified). Dimension FR is maximum motor frame.

FAN SIZE	A	B	BC	BH	C	CA	CC	D	DG	FF	FG	FH	FJ	FK	FL	FN	FR	G	GC	H	HA	HB
165	17.31	13.06	19.50	0.44	17.88	17.50	20.75	21.00	-	2	4.03	2.91	3.00	20.00	16	4	286T	21.25	10.63	46.13	15.13	24.88
182	19.25	14.44	21.25	0.56	19.63	19.25	22.50	23.00	-	2	3.00	3.34	3.25	22.00	16	5	326T	23.50	11.75	49.75	19.50	29.38
200	21.06	15.81	23.38	0.56	21.50	21.13	24.38	25.00	-	2	3.91	3.78	3.50	22.00	16	5	326T	25.00	12.50	51.13	20.56	31.38
222	23.44	17.50	25.50	0.56	23.88	23.50	27.75	27.50	-	2	3.09	4.13	4.00	24.00	24	6	365T	27.38	13.69	53.94	21.94	34.06
245	25.81	19.25	27.75	0.56	26.19	25.81	30.06	30.00	-	3	4.28	3.00	3.00	28.00	24	6	365T	29.63	14.81	55.38	23.50	36.81
270	28.50	21.19	30.25	0.56	28.63	28.25	32.50	32.50	-	3	3.63	3.22	3.38	30.00	24	7	365T	32.25	16.13	57.38	25.19	39.50
300	31.63	23.56	33.63	0.81	31.75	31.38	35.63	31.00	36.00	3	3.19	3.66	3.75	32.00	24	8	365T	35.50	17.75	60.81	29.06	44.88
330	34.94	25.81	37.25	0.81	34.88	34.50	38.75	34.00	39.00	3	2.84	4.28	4.00	34.00	32	9	405T	39.25	19.63	69.69	31.00	48.56
365	38.50	28.63	40.75	0.81	38.63	38.25	42.50	37.00	43.00	4	2.63	3.56	3.38	40.00	32	10	405T	42.75	21.38	75.81	33.50	52.88

FAN SIZE	HC	HD	HE	HF	HG	HH	J	K	KA	KL	KS	L	M	N	P	Q	S	SD	SE	T	V
165	20.06	16.44	15.63	14.75	14.00	13.13	12.94	8.06	8.69	5.00	.50 x .25	25.25	8.50	0.88	40.69	8.94	30.50	1.94	5.50	18.56	40.38
182	22.00	18.13	17.19	16.19	15.31	14.31	13.63	8.75	9.38	5.75	.50 x .25	27.50	9.13	0.88	44.63	9.88	35.25	2.19	6.50	20.81	45.75
200	23.81	19.88	18.81	17.69	16.69	15.56	14.31	9.44	10.06	5.75	.50 x .25	27.50	10.13	0.88	45.31	10.81	35.25	2.19	6.50	22.31	46.75
222	26.19	21.69	20.56	19.38	18.31	17.13	15.13	10.25	10.88	6.75	.63 x .31	28.63	11.25	0.88	48.25	12.00	39.38	2.44	7.50	22.81	52.00
245	28.56	23.75	22.50	21.25	20.00	18.69	16.00	11.13	11.75	6.75	.63 x .31	28.38	12.38	0.88	48.88	13.19	39.38	2.44	7.50	22.81	53.13
270	31.25	26.13	24.69	23.25	21.94	20.50	17.00	12.13	12.75	6.75	.63 x .31	28.38	13.63	0.88	49.88	14.50	39.38	2.69	7.50	22.19	54.38
300	34.38	28.75	27.19	25.63	24.19	22.63	18.19	13.38	14.00	6.75	.63 x .31	29.38	15.13	0.88	52.13	16.06	39.88	2.69	7.50	23.44	56.38
330	37.69	31.56	29.81	28.06	26.44	24.69	19.31	14.50	15.13	8.25	.75 x .38	36.00	16.63	0.88	61.38	17.75	45.00	2.94	9.00	30.00	63.00
365	41.25	34.88	32.94	31.00	29.19	27.25	20.69	15.88	16.50	9.25	.88 x .44	42.13	18.63	0.88	68.88	19.50	48.50	3.44	10.00	33.25	68.50

BC1000152-F

DIMENSIONAL DATA

Arr. 9F M1/M2, Sizes 402 – 600 Non-Rotatable

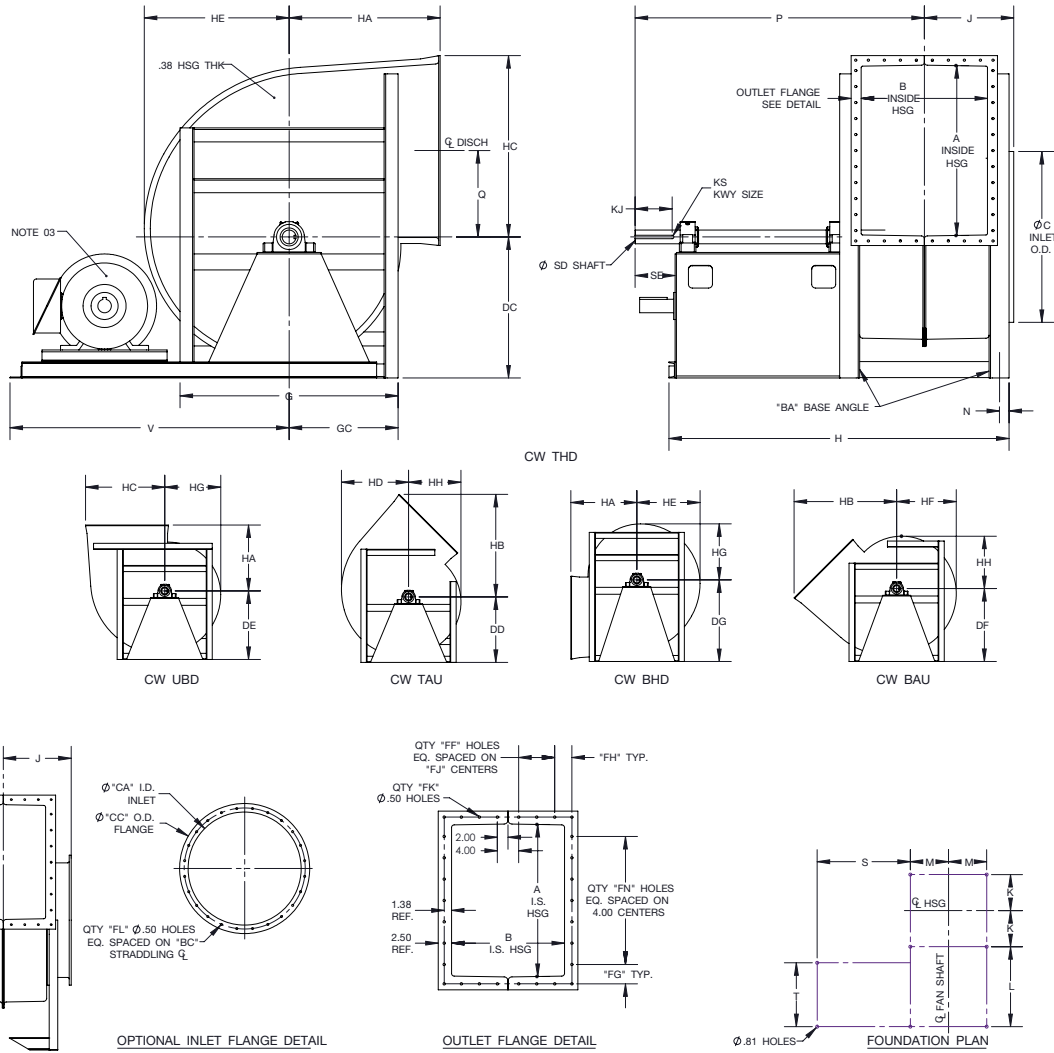

Notes:

1. Outlet flanges are included on all discharges. Drilling is optional.
2. CW rotation is shown, CCW rotation is similar but opposite.
3. Standard Arr. 9F motor location is on the left for CW rotation units and on the right for CCW rotation (unless otherwise specified). Dimension FR is maximum motor frame.

FAN SIZE	A	B	BA	BC	C	CA	CC	DC	DD	DE	DF	DG	FF	FG	FH	FJ	FK	FL	FN	FR	G	GC	H
402	42.44	31.56	3.5 x 5.0	44.63	42.69	42.19	46.44	35.25	37.5	39.25	41.75	46.75	4	2.59	3.16	4.00	42	32	11	445T	54.50	27.25	85.00
445	46.94	34.94	4.0 x 6.0	49.00	47.13	46.63	51.88	37.75	40.75	41.75	45.25	51.25	5	2.84	2.84	3.50	48	40	12	445T	61.00	30.50	90.00
490	51.75	38.38	4.0 x 6.0	53.75	51.88	51.38	56.63	41.25	44.50	46.25	49.75	56.50	5	3.25	3.56	3.75	50	40	13	445T	65.75	32.88	93.44
542	57.19	42.63	4.0 x 6.0	59.25	57.38	56.88	62.13	45.75	48.75	51.25	55.00	61.50	6	3.97	3.19	3.50	56	48	14	445T	71.25	35.63	97.69
600	63.31	47.06	4.0 x 6.0	65.25	63.38	62.88	68.13	50.25	53.50	56.25	59.75	67.50	6	3.03	3.53	3.88	60	48	16	445T	77.25	38.63	102.13

FAN SIZE	HA	HB	HC	HD	HE	HF	HG	HH	J	K	KL	KS	L	M	N	P	Q	S	SD	SE	T	V
402	37.75	58.80	45.31	38.44	36.25	34.19	32.13	30.06	22.38	18.81	9.25	.88 x .44	41.63	19.88	2.38	72.31	21.63	48.50	3.438	10	33.25	69.75
445	42.63	65.13	49.81	42.25	39.81	37.56	35.31	33.06	24.06	21.00	9.25	1.00 x .50	41.75	21.38	2.88	74.63	23.88	48.50	3.938	10	33.25	71.25
490	45.5	70.56	54.63	46.44	43.75	41.25	38.75	36.25	25.75	22.69	9.25	1.00 x .50	41.75	23.88	2.88	76.31	26.25	48.50	3.938	10	33.25	73.75
542	49.06	76.91	60.06	51.25	48.25	45.50	42.75	40.00	27.88	25.19	9.25	1.00 x .50	41.75	26.63	2.88	78.44	29.00	48.50	4.438	10	33.25	76.50
600	52.94	84.00	66.19	56.63	53.31	50.25	47.19	44.13	30.13	27.06	9.25	1.25 x .63	41.75	29.63	2.88	80.69	32.06	48.50	4.938	10	33.25	79.50

BC1000153-D

Arrg. 9F H1/H2, Sizes 165 – 365 Rotatable

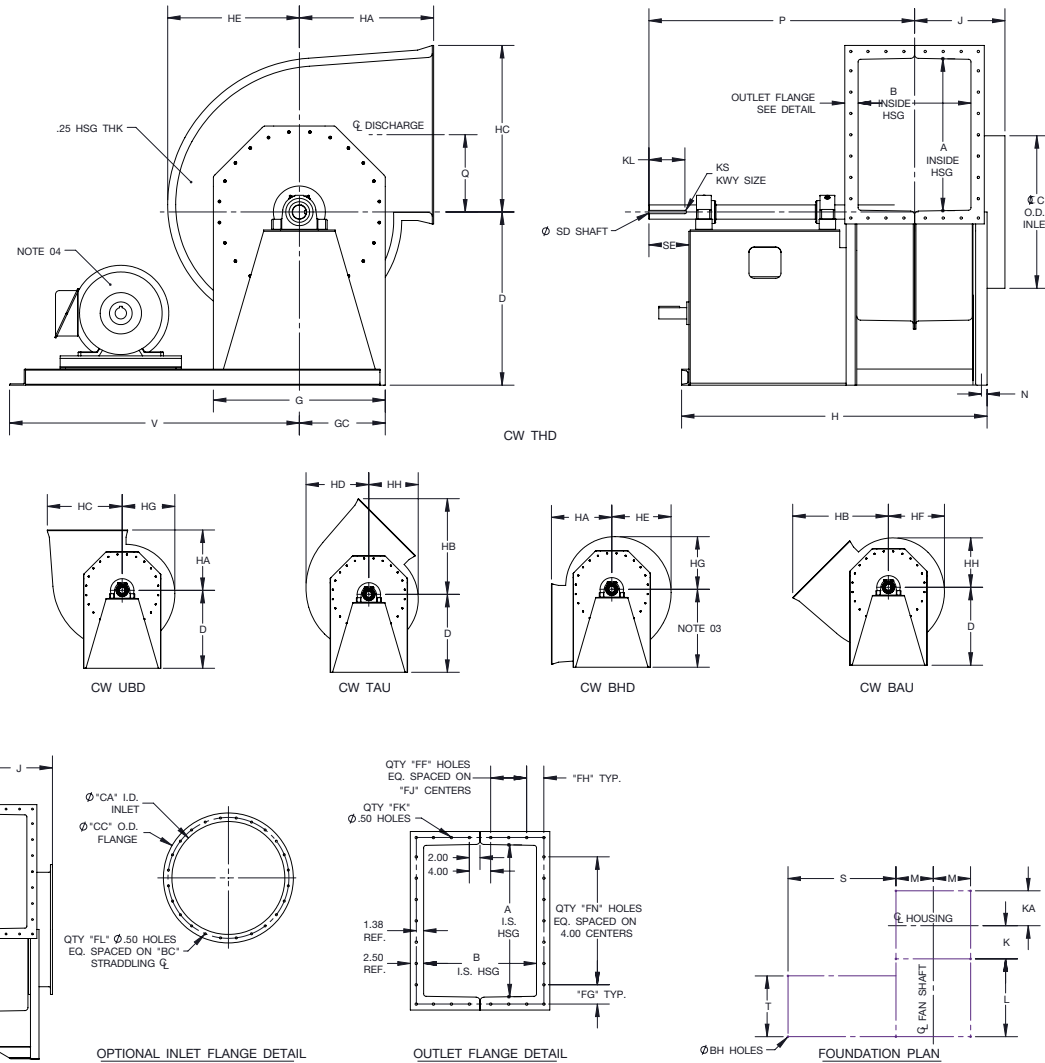

Notes:

1. Outlet flanges are included on all discharges. Drilling is optional.
2. CW rotation is shown, CCW rotation is similar but opposite.
3. All units are rotatable to all positions shown using centerline height Dimension D, except sizes 300-365. Use Dimension DG for 300-365 when BHD discharge is required, otherwise Dimension D will be supplied.
4. Standard Arr. 9F motor location is on the left for CW rotation and on the right for CCW rotation (unless otherwise specified). Dimension FR is maximum motor frame.

FAN SIZE	A	B	BC	BH	C	CA	CC	D	DG	FF	FG	FH	FJ	FK	FL	FN	FR	G	GC	H	HA	HB
165	17.31	11.75	19.50	0.44	17.88	17.50	20.75	21.00	-	2	4.03	2.63	2.63	20	16	4	286T	21.25	10.63	44.81	15.13	24.88
182	19.25	13.00	21.25	0.56	19.63	19.25	22.50	23.00	-	2	3.00	2.94	2.94	22	16	5	326T	23.50	11.75	48.31	19.50	29.38
200	21.06	14.19	23.38	0.56	21.50	21.13	24.38	25.00	-	2	3.91	3.22	3.25	22	16	5	326T	25.00	12.50	49.50	20.56	31.38
222	23.44	15.75	25.50	0.56	23.88	23.50	27.75	27.50	-	2	3.09	3.63	3.63	24	24	6	365T	27.38	13.69	52.19	21.94	34.06
245	25.81	17.31	27.75	0.56	26.19	25.81	30.06	30.00	-	2	4.28	4.03	4.00	24	24	6	365T	29.63	14.81	53.44	23.50	36.81
270	28.50	19.06	30.25	0.56	28.63	28.25	32.50	32.50	-	3	3.63	2.91	3.00	30	24	7	365T	32.25	16.13	55.25	25.19	39.50
300	31.63	21.19	33.63	0.81	31.75	31.38	35.63	31.00	36.00	3	3.19	3.22	3.38	32	24	8	365T	35.50	17.75	58.44	29.06	44.88
330	34.94	23.19	37.25	0.81	34.88	34.50	38.75	34.00	39.00	3	2.84	3.47	3.75	34	32	9	405T	39.25	19.63	67.06	31.00	48.56
365	38.50	25.75	40.75	0.81	38.63	38.25	42.50	37.00	43.00	4	2.63	3.25	3.00	40	32	10	405T	42.75	21.38	72.94	33.50	52.88

FAN SIZE	HC	HD	HE	HF	HG	HH	J	K	KA	KL	KS	L	M	N	P	Q	S	SD	SE	T	V
165	20.06	16.44	15.63	14.75	14.00	13.13	12.31	7.38	8.06	5.00	.50 x .25	25.25	8.50	0.88	40.06	8.94	30.50	1.94	5.50	18.56	40.38
182	22.00	18.13	17.19	16.19	15.31	14.31	12.94	8.06	8.63	5.75	.50 x .25	27.50	9.13	0.88	43.94	9.88	35.25	2.19	6.50	20.81	45.75
200	23.81	19.88	18.81	17.69	16.69	15.56	13.50	8.63	9.25	5.75	.50 x .25	27.50	10.13	0.88	44.50	10.81	35.25	2.19	6.50	22.31	46.75
222	26.19	21.69	20.56	19.38	18.31	17.13	14.25	9.38	10.06	6.75	.63 x .31	28.63	11.25	0.88	47.38	12.00	39.38	2.44	7.50	22.81	52.00
245	28.56	23.75	22.50	21.25	20.00	18.69	15.06	10.19	10.81	6.75	.63 x .31	28.38	12.38	0.88	47.94	13.19	39.38	2.44	7.50	22.81	53.13
270	31.25	26.13	24.69	23.25	21.94	20.50	15.94	11.06	11.69	6.75	.63 x .31	28.38	13.63	0.88	48.81	14.50	39.38	2.69	7.50	22.19	54.38
300	34.38	28.75	27.19	25.63	24.19	22.63	17.00	12.19	12.81	6.75	.63 x .31	29.38	15.13	0.88	50.94	16.06	39.88	2.69	7.50	23.44	56.38
330	37.69	31.56	29.81	28.06	26.44	24.69	18.00	13.19	13.81	8.25	.75 x .38	36.00	16.63	0.88	60.06	17.75	45.00	2.94	9.00	30.00	63.00
365	41.25	34.88	32.94	31.00	29.19	27.25	19.25	14.44	15.06	9.25	.88 x .44	42.13	18.63	0.88	67.44	19.50	48.50	3.44	10.00	33.25	68.50

BC1001159-F

DIMENSIONAL DATA

Arrg. 9F H1/H2, Sizes 402 – 600 Non-Rotatable

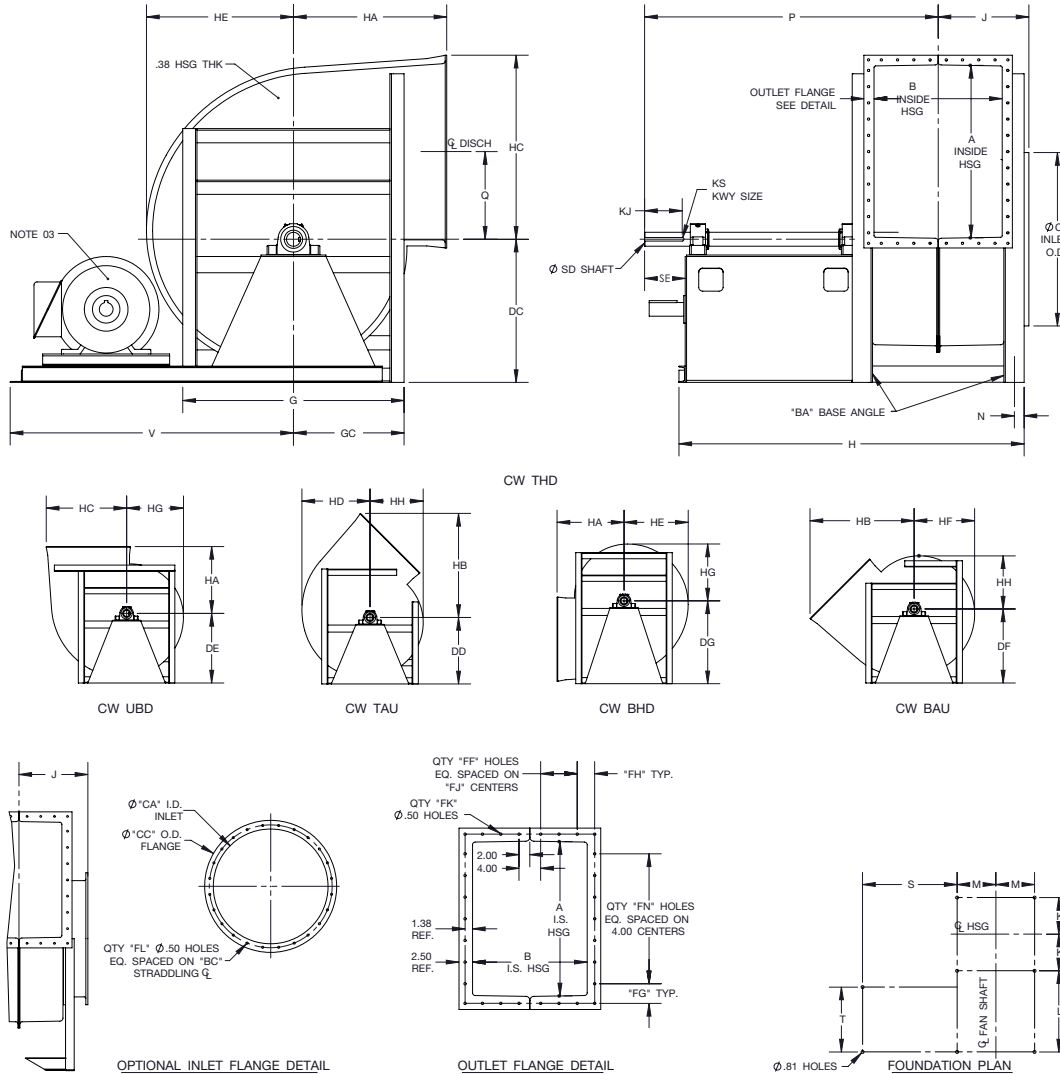

Notes:

1. Outlet flanges are included on all discharges. Drilling is optional.
2. CW rotation is shown, CCW rotation is similar but opposite.
3. Standard Arr. 9F motor location is on the left for CW rotation and on the right for CCW rotation (unless otherwise specified). Dimension FR is maximum motor frame.

FAN SIZE	A	B	BA	BC	C	CA	CC	DC	DD	DE	DF	DG	FF	FG	FH	FJ	FK	FL	FN	FR	G	GC	H
402	42.44	28.38	3.5 x 5.0	44.63	42.69	42.19	46.44	35.25	37.50	39.25	41.75	46.75	4	2.59	3.16	4.00	42	32	11	445T	54.50	27.25	81.81
445	46.94	31.44	4.0 x 6.0	49.00	47.13	46.63	51.88	37.75	40.75	41.75	45.25	51.25	4	2.84	2.84	3.50	44	40	12	445T	61.00	30.50	86.50
490	51.75	34.50	4.0 x 6.0	53.75	51.88	51.38	56.63	41.25	44.50	46.25	49.75	56.50	5	3.25	3.56	3.75	50	40	13	445T	65.75	32.88	89.56
542	57.19	38.25	4.0 x 6.0	59.25	57.38	56.88	62.13	45.75	48.75	51.25	55.00	61.50	5	3.97	3.19	3.50	52	48	14	445T	71.25	35.63	93.31
600	63.31	42.31	4.0 x 6.0	65.25	63.38	62.88	68.13	50.25	53.50	56.25	59.75	67.50	6	3.03	3.53	3.88	60	48	16	445T	77.25	38.63	97.38

FAN SIZE	HA	HB	HC	HD	HE	HF	HG	HH	J	K	KL	KS	L	M	N	P	Q	S	SD	SE	T	V
402	37.75	58.80	45.31	38.44	36.25	34.19	32.13	30.06	20.81	17.19	9.25	.88 x .44	41.63	19.88	2.38	70.75	21.63	48.50	3.44	10.00	33.25	69.75
445	42.63	65.13	49.81	42.25	39.81	37.56	35.31	33.06	22.31	19.25	9.25	1.00 x .50	41.75	21.38	2.88	72.88	23.88	48.50	3.94	10.00	33.25	71.25
490	45.50	70.56	54.63	46.44	43.75	41.25	38.75	36.25	23.81	20.75	9.25	1.00 x .50	41.75	23.88	2.88	74.38	26.25	48.50	3.94	10.00	33.25	73.75
542	49.06	76.91	60.06	51.25	48.25	45.50	42.75	40.00	25.69	22.63	9.25	1.00 x .50	41.75	26.63	2.88	76.25	29.00	48.50	4.44	10.00	33.25	76.50
600	52.94	84.00	66.19	56.63	53.31	50.25	47.19	44.13	27.75	24.69	9.25	1.25 x .63	41.75	29.63	2.88	78.31	32.06	48.50	4.94	10.00	33.25	79.50

BC1000160-E

Arrg. 10 M1/M2, Sizes 165 – 365 Rotatable

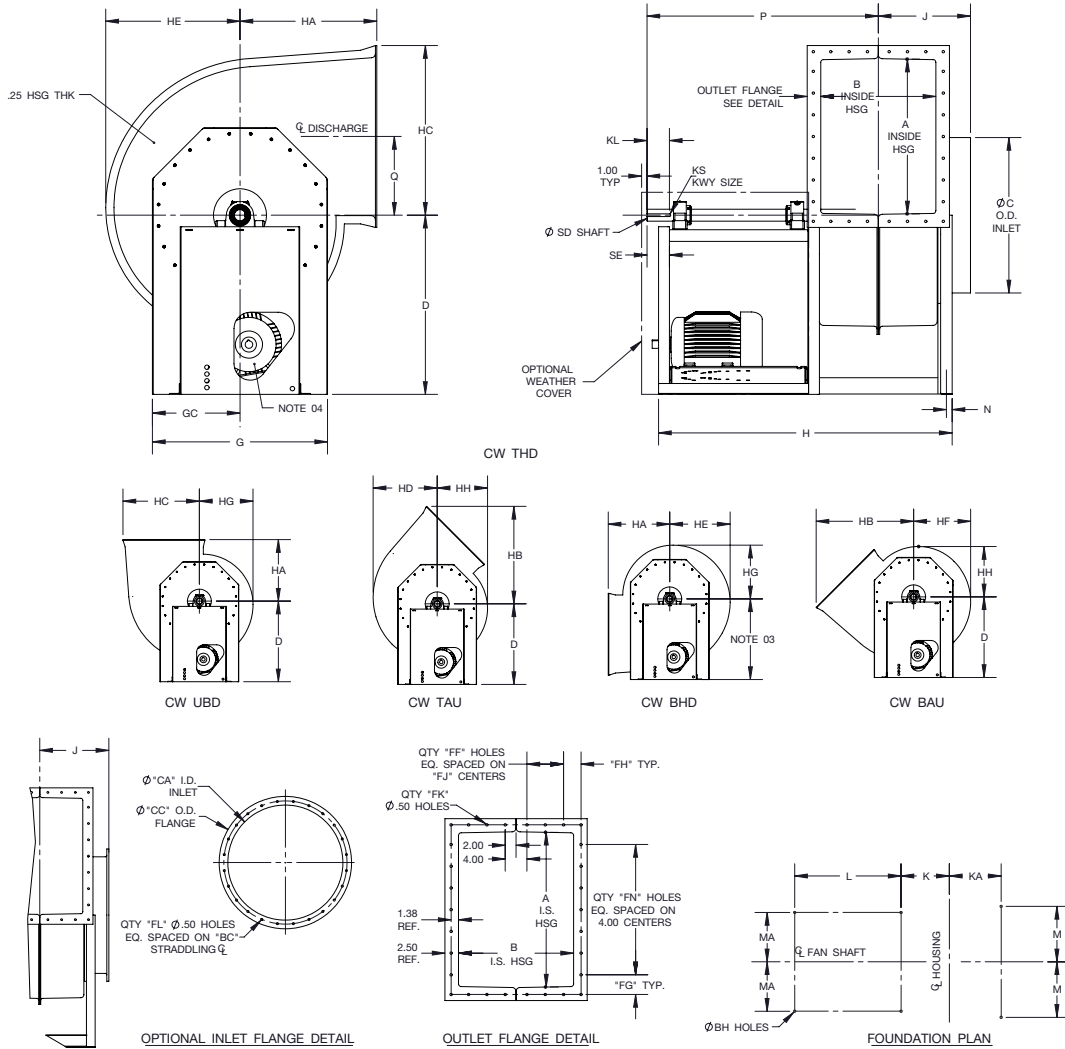

Notes:

1. Outlet flanges are included on all discharges. Drilling is optional.
2. CW rotation is shown, CCW rotation is similar but opposite.
3. All units are rotatable to all positions shown using centerline height Dimension D, except sizes 300-365. Use Dimension DG for 300-365 when BHD discharge is required, otherwise Dimension D will be supplied.
4. Dimension FR is maximum motor frame.

FAN SIZE	A	B	BC	BH	C	CA	CC	D	DG	FF	FG	FH	FJ	FK	FL	FN	FR	G	GC	H	HA
165	17.31	13.06	19.50	0.44	17.88	17.50	20.75	22.00	-	2	4.03	2.91	3.00	20.00	16	4	215T	21.25	10.63	39.00	15.13
182	19.25	14.44	21.25	0.56	19.63	19.25	22.50	24.00	-	2	3.00	3.34	3.25	22.00	16	5	256T	23.50	11.75	45.13	19.50
200	21.06	15.81	23.38	0.56	21.50	21.13	24.38	25.50	-	2	3.91	3.78	3.50	22.00	16	5	256T	25.00	12.50	46.50	20.56
222	23.44	17.50	25.50	0.56	23.88	23.50	27.75	28.00	-	2	3.09	4.13	4.00	24.00	24	6	256T	27.38	13.69	48.19	21.94
245	25.81	19.25	27.75	0.56	26.19	25.81	30.06	30.50	-	3	4.28	3.00	3.00	28.00	24	6	256T	29.63	14.81	49.94	23.50
270	28.50	21.19	30.25	0.56	28.63	28.25	32.50	33.00	-	3	3.63	3.22	3.38	30.00	24	7	286T	32.25	16.13	54.13	25.19
300	31.63	23.56	33.63	0.81	31.75	31.38	35.63	31.00	37.00	3	3.19	3.66	3.75	32.00	24	8	286T	35.50	17.75	56.56	29.06
330	34.94	25.81	37.25	0.81	34.88	34.50	38.75	34.00	40.00	3	2.84	4.28	4.00	34.00	32	9	326T	39.25	19.63	62.31	31.00
365	38.50	28.63	40.75	0.81	38.63	38.25	42.50	37.00	43.50	4	2.63	3.56	3.38	40.00	32	10	326T	42.75	21.38	65.13	33.50

FAN SIZE	HB	HC	HD	HE	HF	HG	HH	J	K	KA	KL	KS	L	M	MA	N	P	Q	SD	SE
165	24.88	20.06	16.44	15.63	14.75	14.00	13.13	12.94	7.56	8.69	2.88	.50 x .25	20.00	8.50	9.25	0.88	30.81	8.94	1.69	3.38
182	29.38	22.00	18.13	17.19	16.19	15.31	14.31	13.63	8.25	9.38	3.50	.50 x .25	24.75	9.13	10.88	0.88	36.38	9.88	1.94	4.00
200	31.38	23.81	19.88	18.81	17.69	16.69	15.56	14.31	8.94	10.06	3.50	.50 x .25	24.63	10.13	10.88	0.88	37.06	10.81	1.94	4.00
222	34.06	26.19	21.69	20.56	19.38	18.31	17.13	15.13	10.00	10.88	3.50	.63 x .31	23.88	11.25	11.13	0.88	37.88	12.00	2.19	4.00
245	36.81	28.56	23.75	22.50	21.25	20.00	18.69	16.00	10.88	11.75	3.50	.63 x .31	23.88	12.38	11.63	0.88	38.75	13.19	2.19	4.00
270	39.50	31.25	26.13	24.69	23.25	21.94	20.50	17.00	11.88	12.75	4.13	.63 x .31	26.13	13.63	12.13	0.88	42.63	14.50	2.19	4.63
300	44.88	34.38	28.75	27.19	25.63	24.19	22.63	18.19	13.38	14.00	4.13	.63 x .31	25.38	15.13	12.38	0.88	43.88	16.06	2.19	4.63
330	48.56	37.69	31.56	29.81	28.06	26.44	24.69	19.31	14.50	15.13	4.50	.75 x .38	28.88	16.63	14.13	0.88	48.88	17.75	2.44	5.25
365	52.88	41.25	34.88	32.94	31.00	29.19	27.25	20.69	15.88	16.50	4.50	.88 x .44	28.88	18.63	14.13	0.88	50.25	19.50	2.44	5.25

BC1000154-F

DIMENSIONAL DATA

Arrg. 10 H1/H2, Sizes 165 – 365 Rotatable

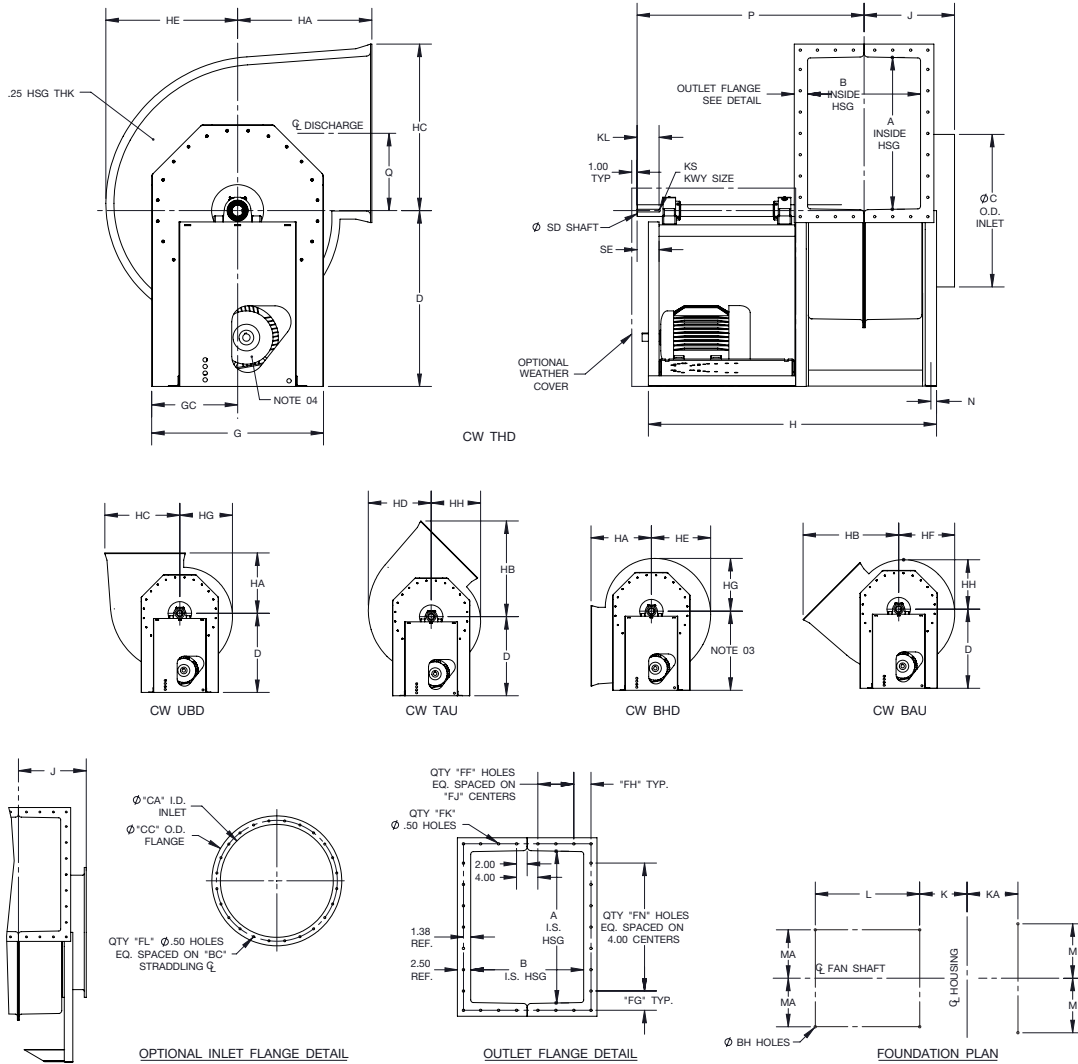

Notes:

1. Outlet flanges are included on all discharges. Drilling is optional.
2. CW rotation is shown, CCW rotation is similar but opposite.
3. All units are rotatable to all positions shown using centerline height Dimension D, except sizes 300-365. Use Dimension DG for 300-365 when BHD discharge is required, otherwise Dimension D will be supplied.
4. Dimension FR is maximum motor frame.

FAN SIZE	A	B	BC	BH	C	CA	CC	D	DG	FF	FG	FH	FJ	FK	FL	FN	FR	G	GC	H	HA
165	17.31	11.75	19.50	0.44	17.88	17.50	20.75	22.00	-	2	4.03	2.63	2.63	20	16	4	215T	21.25	10.63	37.69	15.13
182	19.25	13.00	21.25	0.56	19.63	19.25	22.50	24.00	-	2	3.00	2.94	2.94	22	16	5	256T	23.50	11.75	43.69	19.50
200	21.06	14.19	23.38	0.56	21.50	21.13	24.38	25.50	-	2	3.91	3.22	3.25	22	16	5	256T	25.00	12.50	44.88	20.56
222	23.44	15.75	25.50	0.56	23.88	23.50	27.75	28.00	-	2	3.09	3.63	3.63	24	24	6	256T	27.38	13.69	46.44	21.94
245	25.81	17.31	27.75	0.56	26.19	25.81	30.06	30.50	-	2	4.28	4.03	4.00	24	24	6	256T	29.63	14.81	48.00	23.50
270	28.50	19.06	30.25	0.56	28.63	28.25	32.50	33.00	-	3	3.63	2.91	3.00	30	24	7	286T	32.25	16.13	52.00	25.19
300	31.63	21.19	33.63	0.81	31.75	31.38	35.63	31.00	37.00	3	3.19	3.22	3.38	32	24	8	286T	35.50	17.75	54.19	29.06
330	34.94	23.19	37.25	0.81	34.88	34.50	38.75	34.00	40.00	3	2.84	3.47	3.75	34	32	9	326T	39.25	19.63	59.69	31.00
365	38.50	25.75	40.75	0.81	38.63	38.25	42.50	37.00	43.50	4	2.63	3.25	3.00	40	32	10	326T	42.75	21.38	62.25	33.50

FAN SIZE	HB	HC	HD	HE	HF	HG	HH	J	K	KA	KL	KS	L	M	MA	N	P	Q	SD	SE
165	24.88	20.06	16.44	15.63	14.75	14.00	13.13	12.31	7.38	8.06	2.88	.50 x .25	20.00	8.50	9.25	0.88	30.19	8.94	1.69	3.38
182	29.38	22.00	18.13	17.19	16.19	15.31	14.31	12.94	8.06	8.63	3.50	.50 x .25	24.75	9.13	10.88	0.88	35.69	9.88	1.94	4.00
200	31.38	23.81	19.88	18.81	17.69	16.69	15.56	13.50	8.63	9.25	3.50	.50 x .25	24.63	10.13	10.88	0.88	36.25	10.81	1.94	4.00
222	34.06	26.19	21.69	20.56	19.38	18.31	17.13	14.25	9.38	10.06	3.50	.63 x .31	23.88	11.25	11.13	0.88	37.00	12.00	2.19	4.00
245	36.81	28.56	23.75	22.50	21.25	20.00	18.69	15.06	10.19	10.81	3.50	.63 x .31	23.88	12.38	11.63	0.88	37.81	13.19	2.19	4.00
270	39.50	31.25	26.13	24.69	23.25	21.94	20.50	15.94	11.06	11.69	4.13	.63 x .31	26.13	13.63	12.13	0.88	41.56	14.50	2.19	4.63
300	44.88	34.38	28.75	27.19	25.63	24.19	22.63	17.00	12.19	12.81	4.13	.63 x .31	25.38	15.13	12.38	0.88	42.69	16.06	2.19	4.63
330	48.56	37.69	31.56	29.81	28.06	26.44	24.69	18.00	13.19	13.81	4.50	.75 x .38	28.88	16.63	14.13	0.88	47.56	17.75	2.44	5.25
365	52.88	41.25	34.88	32.94	31.00	29.19	27.25	19.25	14.44	15.06	4.50	.88 x .44	28.88	18.63	14.13	0.88	48.81	19.50	2.44	5.25

BC1000161-F

TYPICAL SPECIFICATIONS

Model

BCSF



Fans shall be Model BCSF, Backward Curved High Pressure Composite Blowers, as manufactured by Twin City Fan & Blower, Minneapolis, Minnesota.

PERFORMANCE — Performance ratings shall conform to AMCA Standard 205 (fan efficiency grade), 211 (air performance) and 311 (sound performance). Fans shall be tested in accordance with ANSI/AMCA Standard 210 (air performance) and 300 (sound performance) in an AMCA accredited laboratory. Fans shall be licensed to bear the AMCA certified ratings seal for both air and sound, and fan efficiency grade (FEG).

Fans shall have a sharply rising pressure characteristic extending through the operating range and continuing to rise beyond the peak efficiency to ensure quiet and stable operation. Fans shall have a non-overloading design with self-limiting horsepower characteristics and shall reach a peak in the normal selection area.

CONSTRUCTION — Fan housing shall be constructed of a general-purpose fire-retardant polyester resin with ASTM E-84 Class 1 flame spread of <25. Housing may be constructed with a fire-retardant vinyl ester resin if required by the application. Airstream surfaces shall be free from imperfections and irregularities to minimize airflow resistance and to prevent contamination build-up. Discharge flanges shall be provided for rigidity and duct connection. Housings shall be suitably braced to prevent distortion and vibration. Shaft hole openings sealed to minimize leakage. Inlet of housing shall be adequately sized to allow for wheel removal. All units are furnished with lifting lugs.

WHEEL — BCSF backward curved wheels shall be single thickness, designed for maximum efficiency and quiet operation. Wheel shall be fabricated of a fire-retardant vinyl ester resin. Blades shall be continuously bonded to the rim and backplate. Wheel hub shall be completely encapsulated to insure corrosion protection. All wheels shall be statically and dynamically balanced.

SHAFT — Shafts shall be AISI 1045 hot rolled steel, accurately turned, ground, polished, and ring gauged for accuracy. Shafts shall be encased in a sleeve securely fixed and bonded to the wheel backplate. The sleeve shall extend out through the housing shaft hole for corrosion protection. Shafts shall be sized for the first critical speed of at least 1.43 times the maximum speed.

BEARINGS — Bearings shall be heavy duty, grease lubricated, anti-friction ball or roller, self-aligning, pillow block type and selected for a minimum average bearing life (AFBMA L-50) in excess of 200,000 hours at the maximum fan RPM.

DRIVE — Motor sheaves shall be cast iron, variable pitch on applications 20 HP and smaller, and fixed pitch on 25 HP and larger. Drives and belts shall be located external to the fan casing and rated for 150% of the required motor HP.

FINISH AND COATING — Exposed steel components excluding the shaft, shall be thoroughly degreased and deburred before application of a rust-preventative primer. After the steel structure is completely assembled, a finish coat of epoxy shall be applied to the entire assembly. The exposed portion of the fan shaft shall be coated with a petroleum-based rust protectant. The housing shall be coated with a suitable coating.

ACCESSORIES — When specified, accessories such as shaft seals, access doors, drains, inlet flanges, belt guards, shaft and bearing guards, outlet dampers, inlet boxes shall be provided by Twin City Fan & Blower to maintain oneshore responsibility.

FACTORY RUN TEST — All fans prior to shipment shall be completely assembled and test run as a unit at the specified operating speed or maximum RPM allowed. Each wheel shall be statically and dynamically balanced in accordance with ANSI/AMCA 204-96 "Balance Quality and Vibration Levels for Fans" to Fan Application Category BV-3, Balance Quality Grade G6.3. Balance readings shall be taken by electronic type equipment in the axial, vertical, and horizontal directions on each of the bearings. Records shall be maintained and a written copy shall be available upon request.

GUARANTEE — The manufacturer shall guarantee the workmanship and materials for at least one (1) year from startup or eighteen (18) months from shipment, whichever occurs first.

INDUSTRIAL & COMMERCIAL FANS

Centrifugal Fans | Utility Sets | Plenum & Plug Fans | Inline Centrifugal Fans

Mixed Flow Fans | Tubeaxial & Vaneaxial Fans | Propeller Wall Fans | Propeller Roof Ventilators

Centrifugal Roof & Wall Exhausters | Ceiling Ventilators | Gravity Ventilators | Duct Blowers

Radial Bladed Fans | Radial Tip Fans | High Efficiency Industrial Fans | Pressure Blowers

Laboratory Exhaust Fans | Filtered Supply Fans | Mancoolers | Fiberglass Fans | Custom Fans



Fan & Blower
Twin City

TWIN CITY FAN & BLOWER | WWW.TCF.COM

5959 Trenton Lane N | Minneapolis, MN 55442 | Phone: 763-551-7600 | Fax: 763-551-7601