

# Model MFA-16

## Extruded Aluminum

### Stationary Louver

4" Deep Drainable Blade

### Specifications

- Frame:** .090" 6063-T5 extruded aluminum channel frame.
- Blades:** .081" 6063-T5 extruded aluminum.
- Screen:** 1/2" x .051" flattened expanded aluminum.
- Finish:** Standard mill.
- Minimum size:** 12"w x 12"h.
- Maximum size:** 72"w x 120"h.  
Multiple section - unlimited size.

### Options

- Flanged frame.
- Architectural mullions.
- Sill extension.
- Sleeves.
- Sub frame (requires flanged louver).
- Screens - Many variations of screens are available, consult factory.
- Finishes - Many types of finishes are available, consult factory.
- Other options available, consult factory.

### Notes

1. Width x height are nominal opening dimensions. Unless specified otherwise, units will be constructed 1/4" undersize.
2. Metal Form reserves the right to improve design or change specifications at any time.

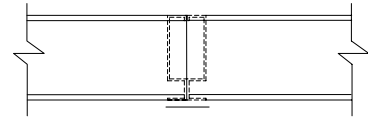
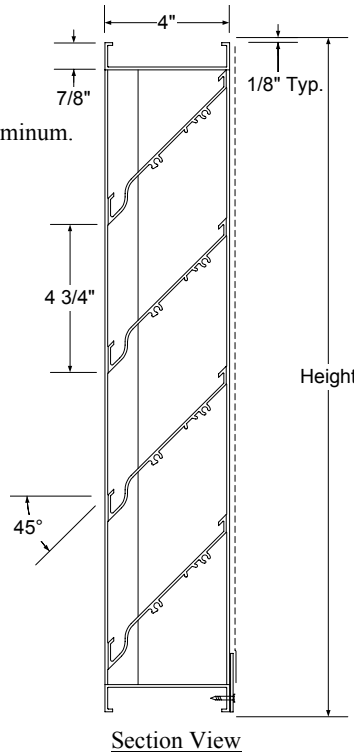

Mullion Detail

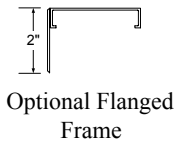

Optional Flanged Frame

**Model MFA-16 is AMCA licensed for air performance and water penetration.**

Tag	Qty.	Width	Height	No. of Panels (W x H)	Options	Finishes/Specify	Remarks

**Project:** \_\_\_\_\_  
**Architect:** \_\_\_\_\_  
**Engineer:** \_\_\_\_\_  
**Contractor:** \_\_\_\_\_

# Model MFA-16 Performance Data

**Air Performance**

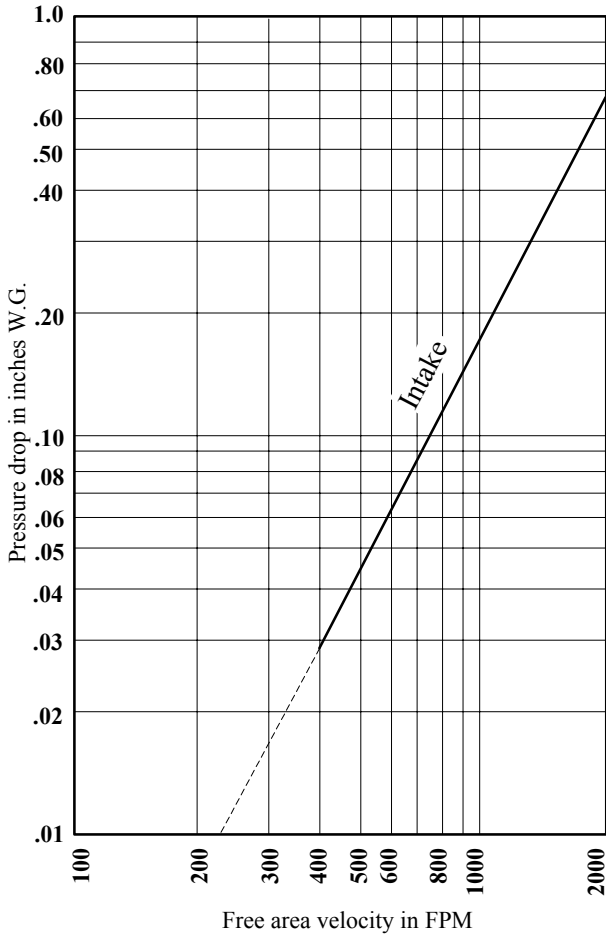

**Water Penetration**

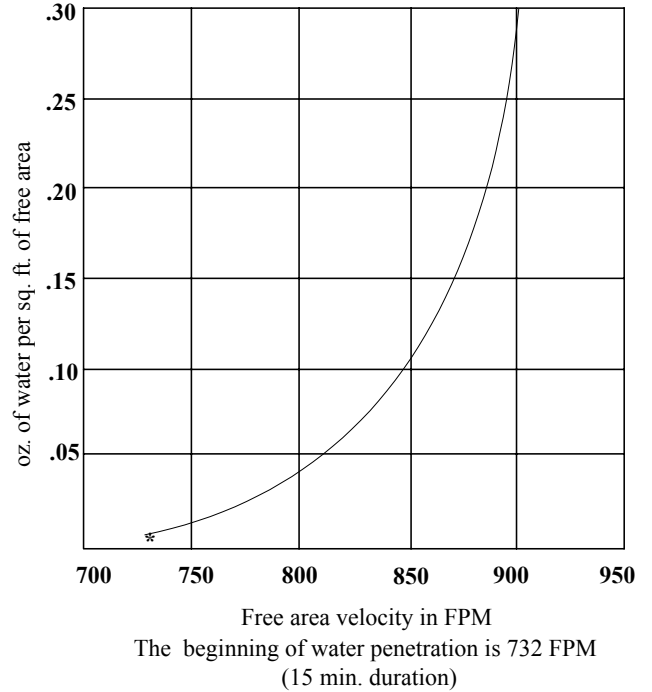

Test unit size 48" x 48"  
 Graphs are corrected to standard air density .075 lbs. per cubic foot.  
 Ratings do not include the effects of a bird screen.



**Free Area Chart - Sq. Ft.**

	120	4.63	7.34	10.05	12.76	15.47	18.18	20.90	23.61	26.32	29.03	31.74
	108	4.10	6.50	8.90	11.30	13.69	16.09	18.49	20.89	23.29	25.69	28.09
	96	3.50	5.71	7.92	10.13	12.34	14.55	16.75	18.96	21.17	23.38	25.59
	84	2.97	4.85	6.72	8.60	10.47	12.35	14.23	16.10	17.98	19.85	21.73
	72	2.57	4.20	5.83	7.45	9.08	10.70	12.33	13.96	15.58	17.21	18.83
	66	2.31	3.77	5.23	6.69	8.15	9.61	11.07	12.53	13.99	15.45	16.90
	60	2.06	3.36	4.67	5.97	7.27	8.57	9.87	11.18	12.48	13.78	15.08
	54	1.88	3.07	4.26	5.44	6.63	7.82	9.00	10.19	11.38	12.57	13.76
	48	1.65	2.69	3.74	4.78	5.82	6.86	7.91	8.95	9.99	11.04	12.08
	42	1.39	2.26	3.14	4.02	4.89	5.77	6.64	7.52	8.40	9.27	10.15
	36	1.15	1.88	2.61	3.34	4.07	4.80	5.53	6.26	6.99	7.72	8.45
	30	0.97	1.59	2.20	2.82	3.43	4.05	4.66	5.28	5.89	6.50	7.12
	24	0.73	1.19	1.65	2.11	2.56	3.02	3.48	3.94	4.40	4.86	5.32
	18	0.46	0.76	1.05	1.34	1.63	1.93	2.22	2.51	2.81	3.10	3.39
	12	0.25	0.40	0.56	0.72	0.87	1.03	1.18	1.34	1.50	1.65	1.81
		12	18	24	30	36	42	48	54	60	66	72

Metal Form certifies that the Model MFA-16 shown herein is licensed to bear the AMCA Seal. The ratings shown are based on tests and procedures performed in accordance with AMCA Publication 511 and comply with the AMCA Certified Ratings Program. The AMCA Certified Ratings Seal applies to air performance ratings and water penetration ratings.